

SUBMITTAL PACKAGE



Date 02/28/2025

Serving Cummins Customers

Cummins power solutions are supported by the largest and best-trained worldwide-certified sales/distributor network in the industry. This network will help you select and install the critical power solution to meet the requirements of your specific application. This same network provides experts with advanced technology to make your life easier while providing a seamless support experience.

IMPORTANT: *The critical power solution information and specifications included in this pdf can be used by the site contractor(s) and/or engineer(s) to assist with planning for and accomplishing the overall power solution installation. Please forward this document to the appropriate personnel, as necessary.*

It is the obligation of the electrical contractor and reviewing engineer to determine that the item quantities and accuracy of this submittal is correct as required for the job. Any inaccuracies or deviations must be addressed with Cummins Inc. before release to manufacturing. Any releases of material to manufacturing by the above parties constitute an acceptance of the accuracy of the submittal. Any changes after release will be viewed as a change order, subject to pricing changes. Please take the time to review this package for accuracy to prevent any after-shipment problems that could cause delay in energization.

Cummins certifies that these drawings, material lists, specification and datasheets have been checked prior to submittal and they:

- accurately depict the proposed equipment*
- provide current information to the date of the submittal and*
- present true and accurate equipment information.*

This Approval Drawing Package is submitted as our interpretation of the project requirements and/or the specifications for this job. Please note that issuance of these submittals shall not be deemed or interpreted as performance nor acceptance of your purchase order terms and conditions.

For questions or comments regarding this submittal, please contact the Cummins Project Manager listed on the title page.



**Sales and
Service**

TABLE OF CONTENTS

Section 1 - PROJECT INFORMATION

Project Bill of Material

Gas Supply Requirements Specification Sheet

Section 2 - GENERATOR SPEC SHEETS

Generator Specification Sheet

Generator Data Sheet

PowerCommand Control (PCC) Specification Sheet

Enclosure Specification Sheet

Exhaust Emission Compliance Statement

Exhaust Emission Data Sheet

Sound Data Sheet

Prototype Test Summary Report

Cooling System Data Sheet

Alternator Data Sheet

Thermal Damage Curve

Section 3 - GENERATOR ACCESSORIES

Battery Charger Specification Sheet

Battery Specification Sheet

Circuit Breaker Specification Sheets

Universal Annunciator Specification Sheet

AUX Input/Output Module Specification Sheet

ProtoNode ProtoAir Specification Sheet

Ground Fault Indication Relay Specification Sheet

Alternator Heater Specification Sheet

Coolant Heater Specification Sheet

Oil Heater Specification Sheet

N.G. Fuel Accessories Specification Sheet

Emergency Stop Switch Specification Sheet

Section 4 - GENERATOR DRAWINGS

Generator Outline Drawing
DC Interconnection Wiring Diagram
AC Interconnection Wiring Diagram
Exhaust Silencer Outline Drawing
Circuit Breaker Outline Drawing
Enclosure Outline Drawing

Section 7 - STARTUP & WARRANTY

Pre-Start up checklist
Generator Training Agenda
Transfer Switch Training Agenda
Planned Maintenance Agreement
Generator Warranty Statement
Transfer Switch Warranty Statement

SECTION 1

PROJECT INFORMATION



Bill of Material

Feature Code	Description	Qty
C1300N6 ENG A331-2 L090-2 C002-2 F267-2 P191-2 B267-2 R002-2 B184-2 A292-2 KX21-2 H609-2 E082-2 H389-2 H557-2 A366-2 A334-2 A333-2 D041-2 H706-2 A466-2 H759-2 H268-2 E089-2 H606-2 KA08-2 L050-2 F065-2 B183-2 A059G917 22837-07 KS53-2 K631-2 H550-2 L026-2	Genset - Spark Ign, Natural Gas, 60Hz, 1300kW QSK60G, 1953 HP, 11.4:1 Duty Rating - Standby Power Listing - UL 2200 Natural Gas Enclosure - Sound Att, LEVEL 2, Galvaneal, Base Mtd, with Exhaust System Compartment Tan Enclosure Color Generator - S7L1D-C41 (ADS #642), 60Hz, Winding 312 - 6 Wire, 120C, 0.8pf Voltage - 277/480, 3ph Exciter / Regulator - PMG, 3 Phase Sensor Heater - Alternator, 120VAC Set Control - Power Command 3.3 MLD Controls Facing Left Radiator Cooled Shutdown - Low Coolant Level Coolant Heater - 240V 1ph / 12000W Engine Governor - Electronic, Isochronous Only Engine Starter - 24 VDC Motor Battery Charging Alternator - Normal Output Engine Air Cleaner - Normal Duty Lube Oil, Engine Filled Prior to Shipment Critical Grade Silencer, Carbon Steel Engine Oil Heater - 240VAC 1PH / 2000W Extension - Oil Drain Extension - Engine Coolant Drain Bargraph - AC Analog Meters Alarm - Audible, Engine Shutdown Manuals in English Battery Rack Battery charger, 120/240VAC Input, 30A/24V output Fuel Strainer - Gaseous, 3in NPT Flexible Fuel Connection- Gaseous, 3in NPT Signals-Aux, Input / Output Relays - Genset Status (User Configured) Ground Fault Indicator w/ Alarm Output Contact Standard Test Report	3



GAS SUPPLY DESIGN BEST PRACTICES

Required:

1. The required fuel pressure and volume **must** be available under **all** operating conditions at the generator set gas inlet (see Location A on Figure 1 for measurement point).
2. The generator must have a dedicated pipe run from the meter, not teed off from other equipment supply pipes.
3. Braided flex piping and dry gas filters are required elements of the piping design, but if improperly sized can be highly restrictive to flow. These components and other restrictive portions of the piping system (valves, elbows, etc.) can, and often should be sized larger than the genset fuel connection.

Recommended:

1. Long pipe runs increase pressure drop, so shorter is better. Elbows & valves increase restriction to flow, piping should be designed with as few of these as possible.
2. It is important to have the final pressure regulator as close to the generator inlet as practical. This allows for higher pressure in the line, as well as helps keep a steady draw on the line during operation.

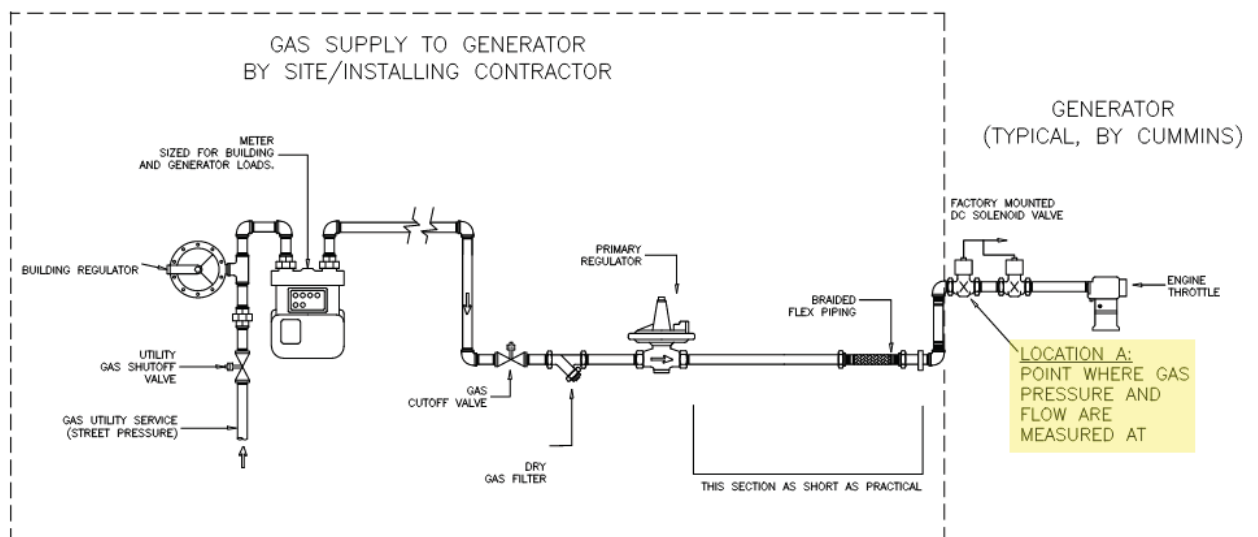

Figure 1. Typical site design

GAS SUPPLY DESIGN BEST PRACTICES

Required:

1. The required fuel pressure and volume **must** be available under **all** operating conditions at the generator set gas inlet (see Location A on Figure 1 for measurement point).
2. The generator must have a dedicated pipe run from the meter, not teed off from other equipment supply pipes.
3. Braided flex piping and dry gas filters are required elements of the piping design, but if improperly sized can be highly restrictive to flow. These components and other restrictive portions of the piping system (valves, elbows, etc.) can, and often should be sized larger than the genset fuel connection.

Recommended:

1. Long pipe runs increase pressure drop, so shorter is better. Elbows & valves increase restriction to flow, piping should be designed with as few of these as possible.
2. It is important to have the final pressure regulator as close to the generator inlet as practical. This allows for higher pressure in the line, as well as helps keep a steady draw on the line during operation.

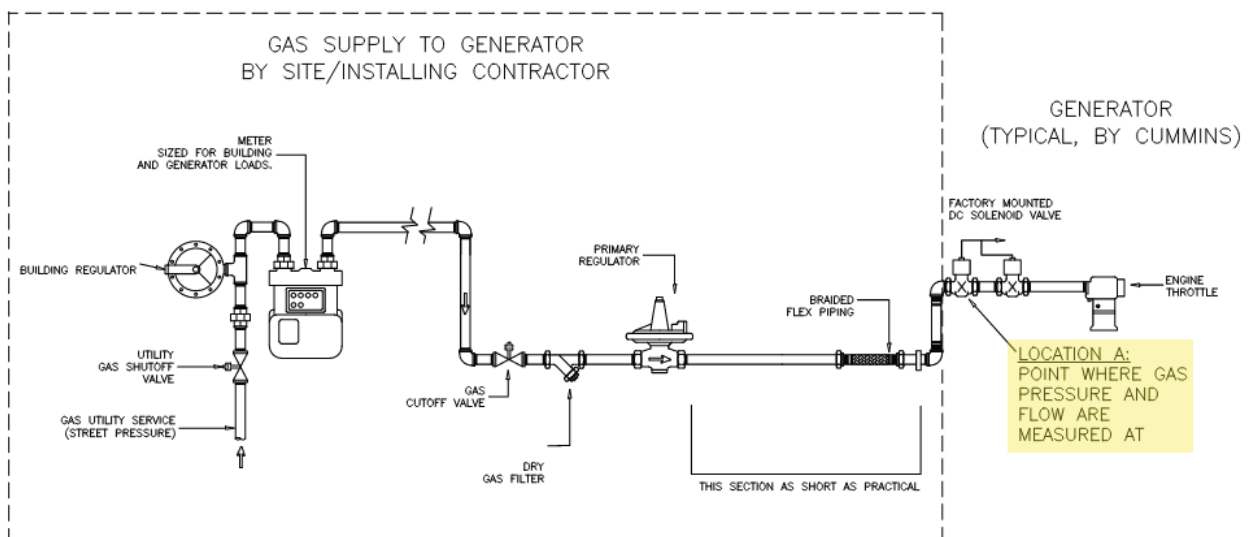

Figure 1. Typical site design



All gas supply piping must be designed by the appropriate engineer and installed by a qualified contractor. Refer to **NFPA 54** for gas pipe sizing information and any related local jurisdiction documents for code compliance on fuel piping installation.

Gas Fuel supply requirements for this generator set:

Fuel source: Natural Gas

Fuel consumption at 100% load: 14,926.0 **SCFH**

Required Operating fuel pressure: 94.0 - 166.0 **in H₂O**

Pressure is measured at the engine inlet solenoid, see Location A on Figure 1

Please note: The pressure listed is not a static pressure. If the above pressure is not maintained while the generator set is operating up to full load, the system will not function as required and the fuel delivery system will need to be corrected to provide operating pressure as listed.

All generators must be installed with a flexible fuel line and fuel strainer prior to the engine connection (**installation by others**):

	<u>Provided by Cummins</u>	<u>Provided by others</u>
Flexible fuel line:	<input checked="" type="checkbox"/>	<input type="checkbox"/>
Fuel strainer:	<input checked="" type="checkbox"/>	<input type="checkbox"/>
Pressure regulator:	<input type="checkbox"/>	<input type="checkbox"/>

If provided by Cummins, see drawings in submittal for flex line and strainer sizing. These optionally provided components may be a larger pipe size than the fuel connection to reduce pressure drop

Contact your Cummins representative for technical assistance.

SECTION 2

**GENERATOR
SPECIFICATIONS**





Specification sheet

Gaseous fuel generator set

1000 kW - 1300 kW
60 Hz

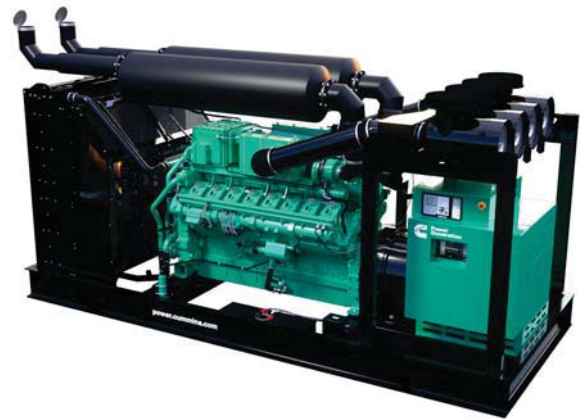

Description

You can count on the 1000-1300 kW natural gas generator set (GenSet) for the reliability, quality, and dependability that is genuine Cummins performance. EPA-certified, this fully-integrated power generation system provides optimum performance and versatility for demand response and stationary standby power applications.

Features

- Over 100 years of Cummins power generation technology and innovation
- Listed to UL 2200 and CSA standards for all low voltage models
- Stamford rugged and reliable alternator with state-of-the-art technology
- One-year (demand response) and two-year (standby) base warranty supported by a worldwide Cummins twenty-four hour, seven days-a-week, distributor network
- Accepts 100% rated load in a single step
- Capable of meeting NFPA 110 Type 10 for Level 1 emergency or standby power supply systems (EPSSs) when installed and operated per Cummins and NFPA guidelines
- Standard Power Command Control (PCC) 3300 technology provides digital (precise) frequency and voltage regulation
- Efficient and convenient operation monitoring and control options:
 - Modbus over the Internet (monitor and control)
 - Remote HMI (monitor and control)

Model	Power rating 60 Hz kW (kVa) Standby and demand response	Emissions	Data sheet
C1000N6B	1000 (1250)	EPA-certified for stationary emergency and non-emergency applications	NAD-C1000N6B
C1300N6	1300 (1625)		NAD-C1300N6

Engine specifications

Base engine	Cummins QSK 60G
Displacement	3671 in ³ (60.1 L)
Minimum battery capacity	1800 amps at minimum ambient temperature of 0 °F (-18 °C)
Battery charging alternator	55 amps
Starting voltage	24-volt, negative ground
Standard cooling system	104 °F (40 °C)

Alternator specifications

Design	Brushless, 4-pole, drip-proof revolving field
Stator	2/3 pitch
Rotor	Direct-coupled by flexible disc
Insulation system	Class H per NEMA MG1-1.65 or better
Standard temperature rise	125 °C
Exciter type	Permanent Magnet Generator (PMG)
Phase rotation	A (U), B (V), C (W)
Alternator cooling	Direct-drive centrifugal blower

Outline drawing

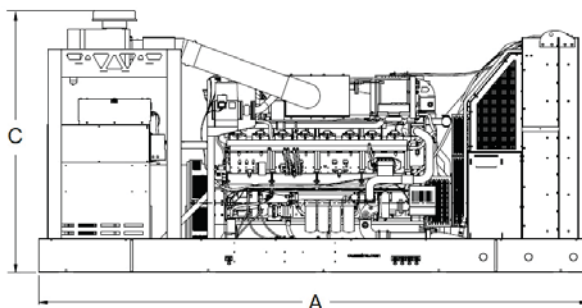
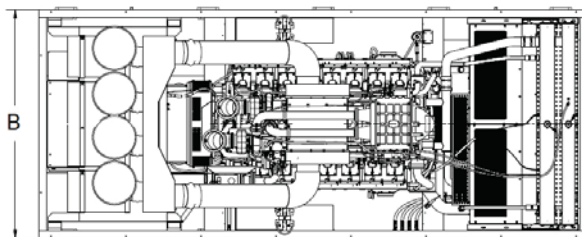

All models	Dim "A" in. (cm)	Dim "B" in. (cm)	Dim "C" in. (cm)
Open-set	240 (610)	102 (259)	115 (292)
Sound-attenuated Level II enclosure	403 (1024)	102 (259)	128 (325)

NOTE: Consult drawings for applicable weights. Contact the factory for additional information.

This outline drawing is for reference only.
Do not use for installation design.

GenSet options and accessories

Alternator

- 80 °C rise
- 105 °C rise
- 125 °C rise
- 120/240 V, 200 W anti-condensation heater

Fuel system - flexible fuel connector and fuel strainer

Exhaust system - critical grade silencer

Generator set

- Batteries
- Battery charger - 120/208/240 V, 20A
- Main line circuit breaker
- Electronically-operated (E.O.) generator breaker
- PowerCommand Network I/O module
- PowerCommand Network Aux 101, 102 module
- Remote control HMI with extension harness
- Remote annunciator panel
- Spring isolators
- Audible alarm
- Sound-attenuated enclosure Level II with silencer
- Warranty - five-year standby including parts, labor, and travel

Applicable codes and standards



The Underwriters Laboratory (UL) 2200 Listing is a comprehensive safety standard encompassing the design, construction, and performance of stationary GenSets.



CSA Group tests products under a formal process to ensure that they meet the safety and/or performance requirements of applicable standards. This GenSet is certified to: CSA 22.2 No. 100 Motors and Generators; CSA 22.2 No. 0.4-044 Bonding of Electrical Equipment; CSA 22.2 No. 14 Industrial Control Equipment; and CSA 22.2 No. 0 General Requirements - Canadian Electrical Code, Part II. All low voltage models are CSA-certified to product class 4215-01.



Engine is certified to Stationary Emergency and Non-Emergency U.S. EPA New Source Performance Standards (NSPS), 40 CFR 60 subpart JJJJ. U.S. applications must be applied per EPA regulations.

ISO 9001:2015

This product has been manufactured under the controls established by an approved management system that conforms with ISO 9001:2015.

PowerCommand 3.3 control system

An integrated microprocessor-based GenSet control system providing voltage regulation, engine protection, AmpSentry alternator protection, operator interface and isochronous governing.



Advanced control methodology

- Designed for reliable operation in harsh environment.
- Provides battery monitoring and testing features and smart starting control system.
- Includes three-phase sensing, full wave rectified voltage regulation, with a PWM output for stable operation with all load types.
- Digitally governed with temperature dynamic governing and integrated digital electronic isochronous governing.
- **Prototype tested** - UL, CSA, and CE compliant.
- **Supports multiple languages**- English, Spanish, and French (standard); other languages, optional.
- **Protects the engine**- cranking lockout, overspeed shutdown, and battleshort; sensor failure indication; low fuel level warning or shutdown; low oil pressure warning and shutdown; high/low coolant temperature warning and shutdown; fail to start (overcrank) and fail to crank shutdown; and battery voltage monitoring, protection, and testing.
- **Enables paralleling control** - direct control of the paralleling breaker and displays breaker status; First Start Sensor System selects first GenSet to close to bus; Phase Lock Loop Synchronizer with voltage matching; sync check relay; isochronous kW and kVar load sharing; load govern control for utility paralleling; extended Paralleling (baseload/peak shave) Mode; and digital power transfer control, for use with a breaker pair to provide open transition, closed transition, ramping closed transition, peaking and base load functions.
- **Includes AmpSentry alternator protection** - over current and short circuit shutdown; over current warning; single and three-phase fault regulation; over and under voltage/frequency shutdown; overload warning with alarm contact; reverse power and reverse var shutdown; and field overload shutdown.
- Cummins InPower PC-based service tool connects to the PowerCommand 3.3 control system for detailed diagnostics, setup, data logging, and fault simulation.
- Comes standard with PCCNet and Modbus interface.
- Allows for up to twenty configurable data inputs and outputs.

State-of-the-art operator panel

- Includes LED lamps indicating GenSet running, remote start, not in auto, common shutdown, common warning, manual run mode, auto mode and stop.
- **Displays engine data** - DC voltage and engine speed; lube oil pressure and temperature; coolant temperature; and comprehensive full authority electronic (FAE) data.
- **Provides GenSet data** - start attempts, starts, running hours, kW hours; load profile (operating hours at percent load in 5% increments); fault history – up to 32 events; data logging and fault simulation (requires InPower); air cleaner restriction indication; exhaust temperature in each cylinder.
- **Includes alternator data** - Line-to-neutral and line-to-line AC volts; three-phase AC current; frequency; kW, kVar, and power factor kVa (three-phase and total); and winding temperature and/or bearing temperature (optional).

Refer to document S-1570 for more detailed information.

100 YEARS OF **POWER** GENERATION

Ratings definitions

Emergency Standby Power (ESP):

Applicable for supplying power to varying electrical load for the duration of power interruption of a reliable utility source. Emergency Standby Power (ESP) is in accordance with ISO 8528. Fuel Stop power is in accordance with ISO 3046, AS 2789, DIN 6271, and BS 5514.

Prime Power (PRP):

Applicable for supplying power to varying electrical load for unlimited hours. Prime Power (PRP) is in accordance with ISO 8528. Ten percent overload capability is available in accordance with ISO 3046, AS 2789, DIN 6271, and BS 5514.

Base Load (Continuous) Power (COP):

Applicable for supplying power continuously to a constant electrical load for unlimited hours. Continuous Power (COP) is in accordance with ISO 8528, ISO 3046, AS 2789, DIN 6271, and BS 5514.

Demand Response Power Rating - Spark Ignited Gas (DRP):

Applicable for supplying electrical power in parallel with commercially available power in variable and non-variable load applications. This fuel rating is intended for use in situations where power outages are contracted, such as in utility power curtailment. Engine operation is limited to a total of 500 hours per year. Engines may be operated in parallel to the public utility for up to 500 hours per year, with an average load factor no greater than 80% of rated Demand Response Power. Engines with Standby Power ratings available can be run in Emergency Standby applications up to the Standby Power rating for up to 50 hours per year. The customer should be aware, however, that the life of any engine will be reduced by constant high load operation.

Warning: Backfeed to a utility system can cause electrocution and/or property damage. Do not connect GenSets to any building electrical system except through an approved device or after the building main disconnect is open. Neutral connection must be bonded in accordance with National Electrical Code.

Specifications are subject to change without notice.

Power You Can Rely On

To order, contact centralregionorders@cummins.com.
Visit cummins.com to view all your power solutions.



Cummins Inc.
Box 3005
Columbus, IN 47202-3005
U.S.A.

1-800-CUMMINS™ (1-800-286-6467)
cummins.com

Printed in U.S.A.
©2022 Cummins Inc.



Generator set data sheet

Model	C1300N6
Frequency	60 Hz
Fuel type	Natural gas
kW (kVa) rating	1300 (1625) standby and demand response
Emissions	EPA-certified for stationary emergency and non-emergency applications

Exhaust emission data sheet	EDS-3079
Sound performance data sheet	MSP-4071
Cooling performance data sheet	MCP-2121
Prototype test summary data sheet	PTS-702
Standard set-mounted radiator cooling outline	C1300N6-01

Fuel consumption	50% load	75% load	full load
Fuel consumption for cfh and m ³ /hr is based on 905 Btu/ft ³ .			
cfh	8157	11,553	14,926
m³/hr	231	327	423
MMBtu/hr	7.38	10.46	13.51

Fuel supply

Fuel supply pressure is measured at the factory-supplied fuel shut-off (FSO) valve.

Minimum operating pressure, in. H₂O (kPa)	94 (23.4)
Maximum operating pressure, in. H₂O (kPa)	166 (41)

Engine	Standby and demand response	Prime
Engine manufacturer	Cummins	
Engine model	QSK 60G	
Configuration	V16	
Aspiration	Turbocharged	
Gross engine power output, bhp (kWm)	1953 (1456)	
BMEP at set rated load, psi (kPa)	234 (1610)	
Bore, in. (mm)	6.25 (159)	
Stroke, in. (mm)	7.48 (190)	
Rated speed, rpm	1800	
Piston speed, ft./min (m/s)	1875 (9.5)	

Engine (cont'd.)	Standby and demand response	Prime
Compression ratio	11.4:1	
Lube oil capacity, qt. (L)	188 (178)	
Overspeed limit, rpm	2150	
Regenerative power, kW	250	

Air

Combustion air, cfm (m ³ /min)	3890 (110)	
Max air cleaner restriction (dirty filter), in. H ₂ O (kPa)	10 (2.5)	

Exhaust

Exhaust flow at set rated load, cfm (m ³ /min)	11840 (335)	
Exhaust temp, °F (°C)	900 (482)	
Max allowable system back pressure, in. H ₂ O (kPa)	20 (5)	

Cooling

Ambient design, °F (°C)	104 (40)	
Fan load, HP (kWm)	99 (73.8)	
Coolant capacity (with radiator), gal (L)	135 (511)	
Cooling system air flow, acfm (m ³ /min)	95,430 (2702)	
Heat rejected, jacket water circuit, Btu/min (MJ/min)	52,602 (55.5)	
Heat rejected, after-cooler circuit, Btu/min (MJ/min)	5822 (6.1)	
Total heat radiated to room, Btu/min (MJ/min)	58,424 (61.64)	
Max cooling air flow static restriction, in. H ₂ O (kPa)	0.5 (0.12)	

Weight

Weight represents a set with standard features. See outline drawing for weights of other configurations.

Unit wet weight lbs. (kgs)	Refer to drawings for specific weights and dimensions

Full-load amperage (FLA) at rated voltage

Three-phase FLA is based on 0.8 power factor (PF).

120/240 (1 Ph)	120/208	127/220	139/240	220/380	240/416	254/440	277/480	347/600
N/A	N/A	N/A	N/A	N/A	N/A	N/A	1955	1564

Engine derates

For non-standard remote installations, contact your local Cummins representative.

Barometer in. Hg (mbar)	SAE standard altitude ft. (m)	Derate factor based on 1300 kWe at ambient temperature °F (°C)							
		68 (20)	77 (25)	86 (30)	95 (35)	104 (40)	113 (45)	122 (50)	131(55)
20.7 (701)	9843 (3000)	0.71	0.69	0.68	0.67	0.65	0.62	0.58	0.55
21.4 (723)	9022 (2750)	0.74	0.73	0.71	0.70	0.69	0.65	0.62	0.58
22.1 (747)	8202 (2500)	0.78	0.76	0.75	0.73	0.72	0.68	0.65	0.62
22.8 (771)	7382 (2250)	0.81	0.80	0.78	0.77	0.75	0.72	0.68	0.65
23.5 (795)	6562 (2000)	0.84	0.83	0.81	0.80	0.79	0.75	0.72	0.68
24.3 (820)	5741(1750)	0.88	0.86	0.85	0.83	0.82	0.79	0.75	0.72
25.0 (846)	4921(1500)	0.91	0.90	0.88	0.87	0.85	0.82	0.78	0.75
25.8 (872)	4101 (1250)	0.94	0.93	0.91	0.90	0.89	0.85	0.82	0.78
26.6 (899)	3281 (1000)	0.98	0.96	0.95	0.93	0.92	0.89	0.85	0.82
27.4 (926)	2461 (750)	1.00	1.00	0.98	0.97	0.95	0.92	0.88	0.85
28.3 (954)	1640 (500)	1.00	1.00	1.00	1.00	0.99	0.95	0.92	0.88
29.1 (983)	820(250)	1.00	1.00	1.00	1.00	1.00	0.99	0.95	0.92
29.5 (995)	492 (150)	1.00	1.00	1.00	1.00	1.00	1.00	0.96	0.93
30.0 (1012)	0	1.00	1.00	1.00	1.00	1.00	1.00	0.98	0.95

Ratings definitions

Emergency standby power (ESP):

Applicable for supplying power to varying electrical load for the duration of power interruption of a reliable utility source. Emergency Standby Power (ESP) is in accordance with ISO 8528. Fuel Stop power is in accordance with ISO 3046, AS 2789, DIN 6271, and BS 5514.

Prime power (PRP):

Applicable for supplying power to varying electrical load for unlimited hours. Prime Power (PRP) is in accordance with ISO 8528. Ten percent overload capability is available in accordance with ISO 3046, AS 2789, DIN 6271, and BS 5514.

Base load (continuous) power (COP):

Applicable for supplying power continuously to a constant electrical load for unlimited hours. Continuous Power (COP) is in accordance with ISO 8528, ISO 3046, AS 2789, DIN 6271, and BS 5514.

Demand Response Power Rating - Spark Ignited Gas (DRP):

Applicable for supplying electrical power in parallel with commercially available power in variable and non-variable load applications. This fuel rating is intended for use in situations where power outages are contracted, such as in utility power curtailment. Engine operation is limited to a total of 500 hours per year. Engines may be operated in parallel to the public utility for up to 500 hours per year, with an average load factor no greater than 80% of rated Demand Response Power. Engines with Standby Power ratings available can be run in Emergency Standby applications up to the Standby Power rating for up to 50 hours per year. The customer should be aware, however, that the life of any engine will be reduced by constant high load operation.

ISO 9001:2015

This product has been manufactured under the controls established by an approved management system that conforms with ISO 9001:2015.

Warning: Backfeed to a utility system can cause electrocution and/or property damage. Do not connect GenSets to any building electrical system except through an approved device or after the building main disconnect is open. Neutral connection must be bonded in accordance with National Electrical Code.

Specifications are subject to change without notice.

Power You Can Rely On

To order, contact centralregionorders@cummins.com.
Visit cummins.com to view all your power solutions.



Cummins Inc.
Box 3005
Columbus, IN 47202-3005
U.S.A.

1-800-CUMMINS™ (1-800-286-6467)
cummins.com

Printed in U.S.A.
©2022 Cummins Inc.



PowerCommand® 3.3 Generator Set Digital Integrated Control System



Bargraph Optional

Introduction

The PowerCommand® 3.3 control system is a microprocessor-based generator set monitoring, metering, and control system, which is comprised of PowerCommand® Control 3300 and the Human Machine Interface 320. PCC3300 supports multiple operation modes including:

- Standalone,
- Synchronization only,
- Isolated bus paralleling,
- Utility single generator set paralleling,
- Utility multiple generator set paralleling,
- Utility single generator set paralleling with power transfer control (automatic mains failure),
- Isolated bus paralleling with Masterless Load Demand

PowerCommand® Control 3300 is designed to meet the exacting demands of the harsh and diverse environments of today's typical power generation applications for Full Authority Electronic or Hydromechanical engine power generator sets.

Offering enhanced reliability and performance over more conventional generator set controls via the integration of all generator control functions into a single system, PCC3300 is your Power of One generator set control solution.

Benefits and Features

- 320 x 240 pixels graphical LED backlit LCD
- Multiple languages supported
- AmpSentry™ protection provides industry-leading generator overcurrent protection
- Digital Power Transfer Control (Automatic Mains Failure) provides load transfer operation in open transition, closed transition, or soft (ramping) transfer modes

- Extended Paralleling (Peak Shave/Base Load) regulates the genset real and reactive power output while paralleled to the utility. Power can be regulated at either the genset or utility bus monitoring point
- Digital frequency synchronization and voltage matching
- Isochronous Load Sharing
- Droop kW and kVAr control
- Real time clock for fault and event time stamping
- Exerciser clock and time of day start/stop initiate a test with or without load, or a Base Load or Peak Shave session
- Digital automatic voltage regulation is provided using three phase sensing and full wave FET type regulator, which is compatible with either shunt or PMG excited systems with a standard AUX103 AVR or an option for a more powerful high-current field drive capability AUX106 AVR
- Digital engine speed governing is provided on applicable platforms
- Generator set monitoring (including metering) and protection with PCC3300 measuring voltage, current, kW and kVAr offering a measurement accuracy of 1%
- Utility / AC Bus metering and protection with PCC3300 voltage, current, kW and kVAr offering a measurement accuracy of 1%
- 12 V (DC) and 24 V (DC) battery operation
- RS-485 Modbus® interface for interconnecting to customer equipment
- Warranty and service – Cummins Power Generation offers a comprehensive warranty and worldwide distributor service network
- Global regulatory certification and compliance: PCC3300 is suitable for use on gensets that are designed, manufactured, tested and certified to relevant UL, NFPA, ISO, IEC, Mil Std., UKCA, and CE standards

PowerCommand® Generator Set Digital Control System PCC 3300



Introduction

PCC3300 is an industry-leading digital generator set control suitable for usage on a wide range of diesel and lean burn natural gas generator sets in both standalone as well as paralleling applications.

PowerCommand® is compatible with either shunt or PMG excitation, and is suitable for usage with reconnectable or non-reconnectable generators. Configuration for any frequency, voltage and power connection from 120 V (AC) to 600 V (AC) line-to-line or 601 V (AC) to 45k V (AC) with an external PT is supported. The PCC3300 derives its own power from the generator set starting batteries and functions over a voltage range of 8 V (DC) to 30 V (DC).

Features

- PCC3300 supports configurable control features via software download using InPower PC-compatible software
- 12 V (DC) and 24 V (DC) battery operation
- Digital automatic voltage regulation is provided using three phase sensing and full wave FET type regulator, which is compatible with either shunt or PMG excited systems with a standard AUX103 AVR or an option for a more powerful high-current field drive capability AUX106 AVR
- Digital engine speed governing on applicable platform is provided, which is capable of providing isochronous frequency regulation
- Full authority J1939 CANBus® prime mover communications and control is provided for platforms with an Engine Control Module (ECM)
- AmpSentry™ protection provides industry-leading alternator overcurrent protection:
 - Time-based generator protection applicable to both line-to-line and line-to-neutral, that can detect an unbalanced fault condition and swiftly react appropriately. Balanced faults can also be detected by AmpSentry and appropriate acted upon.
 - Reduces the risk of Arc Flash due to thermal overload or electrical faults by inverse time protection

- Generator set monitoring offers status information for all critical prime mover and generator functions
- AC and DC digital generator set metering is provided. AC measurements are configurable for single or three phase sensing with PCC3300 measuring voltage, current, kW and kVAr offering a measurement accuracy of 1%
- Battery monitoring system continually monitors the battery output and warns of the potential occurrence of a weak battery condition
- Relay drivers for prime mover starter, fuel shutoff (FSO), glow plug/spark ignition power and switched B+ applications are provided
- Integrated generator set protection is offered to protect the prime mover and generator
- Real time clock for fault and event time stamping
- Exerciser clock and time of day start/stop initiate a test with or without load, or a Base Load or Peak Shave session
- Digital Power Transfer Control (Automatic Mains Failure) provides load transfer operation in open transition, closed transition, or soft (ramping) transfer modes
- Extended Paralleling (Peak Shave/Base Load) regulates the genset real and reactive power output while paralleled to the utility. Power can be regulated at either the genset or utility bus monitoring point
- Digital frequency synchronization and voltage matching
- Isochronous Load Sharing
- Droop kW and kVAr Control
- The synchronization check function provides adjustments for phase angle window, voltage window, frequency window and time delay
- Utility / AC Bus metering and protection with PCC3300 voltage, current, kW and kVAr offering a measurement accuracy of 1%
- Advanced serviceability is offered via InPower™, a PC-based software service tool
- PCC3300 is designed for reliable operation in harsh environments with the unit itself being a fully encapsulated module
- RS-485 ModBus interface for interconnecting to customer equipment
- Native on PCC3300: Four discrete inputs, two dry contact relay outputs and two low-side driver outputs are provided and are all configurable.
 - Optional extra PCC3300 input and output capability available via AUX101
- Warranty and service – Cummins Power Generation offers a comprehensive warranty and worldwide distributor service network
- Global regulatory certification and compliance: PCC3300 is suitable for use on gensets that are designed, manufactured, tested and certified to relevant UL, NFPA, ISO, IEC, Mil Std., UKCA and CE standards

Base Control Functions

HMI capability

Options: Local and remote HMI320 options are available

Operator adjustments: The HMI320 includes provisions for many set up and adjustment functions.

Genset hardware data: Access to the control and software part number, genset rating in kVA and genset model number is provided from the HMI320 or InPower.

Data logs: Information concerning all of the following parameters is periodically logged and available for viewing; engine run time, controller on time, number of start attempts, total kilowatt hours, and load profile. (Control logs data indicating the operating hours at percent of rated kW load, in 5% increments. The data is presented on the operation panel based on total operating hours on the generator.)

Fault history: Provides a record of the most recent fault conditions with control date and time stamp. Up to 32 events are stored in the control non-volatile memory.

Alternator data

- Voltage (single or three phase line-to-line and line-to-neutral)
- Current (single or three phase)
- kW, kVAR, Power Factor, kVA (three phase and total)
- Frequency

For Lean Burn Natural Gas Engine applications:

- Alternator heater status
- Alternator winding temperature (per phase) as well as alternator drive end and non-drive end bearing

Utility/AC bus data

- Voltage (three phase line-to-line and line-to-neutral)
- Current (three phase and total)
- kW, kVAR, Power Factor, kVA (three phase and total)
- Frequency

AmpSentry: 3x current regulation for downstream tripping/motor inrush management. Thermal damage curve (3-phase short) or fixed timer (2 sec for 1-Phase Short or 5 sec for 2-Phase short).

Engine data

- Starting battery voltage
- Engine speed
- Engine temperature
- Engine oil pressure
- Engine oil temperature
- Intake manifold temperature
- Coolant temperature
- Comprehensive Full Authority Engine (FAE) data (where applicable)

Lean Burn Natural Gas (LBNG) application parameters include:

- Safety shutoff valve status
- Valve proving status
- Downstream gas pressure
- Gas inlet pressure
- Gas mass flow rate
- Control valve position
- Gas outlet pressure
- Manifold pressure and temperature
- Throttle position
- Compressor outlet pressure
- Turbo speed
- Compressor bypass position
- Cylinder configuration (e.g., drive end and non-drive end configurations)
- Coolant pressure 1 and 2 as well as coolant temperature 1 and 2 for both HT/LT respectively
- Exhaust port temperature (up to 18 cylinders)
- Pre-filter oil pressure
- Exhaust back pressure
- Parent ECM internal temperature and isolated battery voltage
- Speed bias
- Child ECM internal temperature and isolated battery voltage
- Knock level, spark advance, and knock count (for up to 18 cylinders)
- Auxiliary supply disconnecter status
- Engine heater status
- Coolant circulating pump status
- Lube oil priming pump status
- Lube oil status
- Oil heater status
- Derate authorization status
- Start system status
- Ventilator fan status
- Ventilation louvre status
- Radiator fan status
- DC PSU status
- Start inhibit/enable status and setup

Service adjustments – The HMI320 includes provisions for adjustment and calibration of genset control functions. Adjustments are protected by a password. Functions include:

- Engine speed governor adjustments
- Voltage regulation adjustments
- Cycle cranking
- Configurable fault set up
- Configurable input and output set up
- Meter calibration
- Paralleling setup
- Display language and units of measurement

Prime Mover Control

SAE-J1939 CAN interface to full authority ECMs (where applicable). Provides data transfer between genset and engine controller for control, metering and diagnostics.

12 V (DC) or 24 V (DC) nominal battery voltage is supported by PCC3300 for normal operation.

Temperature dependant prime mover governing dynamics: This function is supported enabling the engine to be responsive when warm and more stable when operating at lower temperature via providing control and modification over electronic governing parameters as a function of engine temperature.

Isochronous governing is provided in order to control prime mover speed within $\pm 0.25\%$ of nominal rated speed for any steady state load from no load to full load. During operation frequency drift should not exceed $\pm 0.5\%$ of nominal frequency given a 33°C (or 60°F) change in ambient temperature within an eight-hour period.

Droop electronic speed is governing capability is natively offered by PCC3300 to permit droop from 0% to 10% between no load to full load.

Remote start capability is built into the PCC3300 as the unit accepts a ground signal from remote devices to automatically command the starting of the generator set as well as the reaching of rated speed, voltage and frequency or otherwise run at idle speed until prime mover temperature is adequate. The presence of a remote start signal shall cause the PCC3300 to leave sleep mode and return to normal power mode. PCC3300 supports an option for delayed start or stop.

Remote Start Integrity: In compliance with NEC2017 Start Signal Integrity standard – NFPA70 Article 700.10(D)(3), the remote start circuit from ATS to PCC3300 is continuously monitored for signal disturbance due to broken, disconnected or shorted wires via a configurable input. Loss of signal integrity results in activation of a remote start signal.

Remote and local emergency stopping capability: PCC3300 accepts ground signal from a locally or remotely mounted emergency stop switch to cause the generator set to immediately shutdown. The generator set is prevented from either running or cranking with the emergency stop switch engaged. If PCC3300 is in sleep mode, then the activation of any emergency stop switch shall return PCC3300 to normal powered state along with the activation of the corresponding shutdown and run-prevention states.

Sleep mode: PowerCommand 3.3 supports a configurable low current draw state, which is designed with consideration to the needs of prime applications or other applications without a battery charger (in order to minimize battery current drain).

Automatic prime mover starting: Any generator set controlled by PCC3300 is capable of automatic starting achieved via either magnetic pickup or main alternator output frequency. PCC3300 additionally supports

configurable glow plug control where applicable.

Prime mover cycle cranking: PCC3300 supports configurable starting cycles and rest periods. Built-in starter protection is incorporated to prevent the operator from specifying a starting sequence that may be damaging.

Configurable time delay functionality: PCC3300 supports time delayed generator set starting and stopping (for cooldown). Permissible time delays are as follows (noting a default setting is 0 seconds):

1. Start delay: 0 seconds to 300 seconds prior to starting after receiving a remote start signal.
2. Stop delay: 0 seconds to 600 seconds prior to shut down after receiving a signal to stop in normal operation modes.

Lean Burn Natural Gas application specific parameters

PCC3300 supports prime mover inhibiting in order to permit application-specific processes (i.e. Auxiliaries) to be started first.

Generator Control

PCC3300 performs both Genset voltage sensing and Genset voltage regulation as follows:

- Voltage sensing is integrated into PCC3300 via three phase line-to-line sensing that is compatible with shunt or PMG excitation systems
- Automatic voltage regulation is accomplished by using a three phase fully rectified input and has a FET output for good motor starting capability.

Major features of generator control include:

Digital output voltage regulation - Capable of regulating output voltage to within $\pm 1.0\%$ for any loads between no load and full load. Voltage drift will not exceed $\pm 1.5\%$ for a 40 °C (104 °F) change in temperature in an eight-hour period. On engine starting or sudden load acceptance, voltage is controlled to a maximum of 5% overshoot over nominal level.

The automatic voltage regulator feature can be disabled to allow the use of an external voltage regulator.

Droop voltage regulation - Control can be adjusted to droop from 0-10% from no load to full load.

Torque-matched V/Hz overload control - The voltage roll-off set point and rate of decay (i.e. the slope of the V/Hz curve) is adjustable in the control.

Fault current regulation - PowerCommand[®] will regulate the output current on any phase to a maximum of three times rated current under fault conditions for both single phase and three phase faults. In conjunction with a permanent magnet generator, it will provide three times rated current on all phases for motor starting and short circuit coordination purpose.

Cylinder Cut-off System (CCS): PCC 3300 supports Cylinder Cut-off System which is used to operate the engines on half bank at no load and light load conditions. CCS has the following benefits on engine

performance- improved emission standards, improved fuel efficiency, reduced hydrocarbons, reduced white smoke, reduced wet stacking and higher exhaust temperature at light loads to improve turbocharger operations and catalyst performance.

Step Timing Control (STC): PCC 3300 supports STC functionality which is used to advance the engine timing of a hydro-mechanical engine during start up and light load conditions. During ADVANCED injection timing, it:

- Improves cold weather idling characteristics
- Reduces cold weather white smoke
- Improves light load fuel economy
- Reduces injector carboning

Paralleling Functions

First Start Sensor™ system – PowerCommand® provides a unique control function that positively prevents multiple gensets from simultaneously closing to an isolated bus under black start conditions. The First Start Sensor system is a communication system between the gensets that allows the gensets to work together to determine which genset is a system should be the first to close to the bus. The system includes an independent backup function, so that if the primary system is disabled the required functions are still performed.

Synchronizing – Control incorporates a digital synchronizing function to force the genset to match the frequency, phase and voltage of another source such as a utility grid. The synchronizer includes provisions to provide proper operation even with highly distorted bus voltage waveforms. The synchronizer can match other sources over a range of 60-110% of nominal voltage and -24 to +6 hertz. The synchronizer function is configurable for slip frequency synchronizing for applications requiring a known direction of power flow at instant of breaker closure or for applications where phase synchronization performance is otherwise inadequate.

Load sharing control – The genset control includes an integrated load sharing control system for both real (kW) and reactive (kVar) loads when the genset(s) are operating on an isolated bus. The control system determines kW load on the engine and kVar load on the alternator as a percent of genset capacity, and then regulates fuel and excitation systems to maintain system and genset at the same percent of load without impacting voltage or frequency regulation. The control can also be configured for operation in droop mode for kW or Kvar load sharing.

Load govern control– When PowerCommand® receives a signal indicating that the genset is paralleled with an infinite source such as a utility (mains) service, the genset will operate in load govern mode. In this mode the genset will synchronize and close to the bus, ramp to a pre-programmed kW and kVar load level, and then operate at that point. Control is adjustable for kW

values from 0-100% of standby rating, and 0.7-1.0 power factor (lagging). Default setting is 80% of standby and 1.0 power factor. The control includes inputs to allow independent control of kW and kVar load level by a remote device while in the load govern mode. The rate of load increase and decrease is also adjustable in the control. In addition, the control can be configured for operation in kW or kVAR load govern droop.

Load demand control – The control system includes the ability to respond to an external signal to initiate load demand operation. On command, the genset will ramp to no load, open its paralleling breaker, cool down, and shut down. On removal of the command, the genset will immediately start, synchronize, connect, and ramp to its share of the total load on the system.

Sync check – The sync check function decides when permissive conditions have been met to allow breaker closure. Adjustable criteria are: phase difference from 0.1-20 deg, frequency difference from 0.001-1.0 Hz, voltage difference from 0.5-10%, and a dwell time from 0.5-5.0 sec. Internally the sync check is used to perform closed transition operations. An external sync check output is also available.

Genset and utility/AC bus source AC metering – The control provides comprehensive three phase AC metering functions for both monitored sources, including: 3-phase voltage (L-L and L-N) and current, frequency, phase rotation, individual phase and totalized values of kW, kVAR, kVA and Power Factor; totalized positive and negative kW-hours, kVAR-hours, and kVA-hours. Three wire or four wire voltage connection with direct sensing of voltages to 600V, and up to 45kV with external transformers. Current sensing is accomplished with either 5 amp or 1 CT secondaries and with up to 10,000 amp primary. Maximum power readings are 32,000kW/kVAR/kVA.

Power transfer control – provides integrated automatic power transfer functions including source availability sensing, genset start/stop and transfer pair monitoring and control. The transfer/retransfer is configurable for open transition, fast closed transition (less than 100msec interconnect time), or soft closed transition (load ramping) sequences of operation. Utility source failure will automatically start genset and transfer load, retransferring when utility source returns. Test will start gensets and transfer load if test with load is enabled. Sensors and timers include:

Under voltage sensor: 3-phase L-N or L-L under voltage sensing adjustable for pickup from 85-100% of nominal. Dropout adjustable from 75-98% of pickup. Dropout delay adjustable from 0.1-30 sec.

Over voltage sensor: 3-phase L-N or L-L over voltage sensing adjustable for pickup from 95-99% of dropout. Dropout adjustable from 105-135% of nominal. Dropout delay adjustable from 0.5-120 sec. Standard configuration is disabled and is configurable to enabled in the field using the HMI or InPower service tools.

Over/Under frequency sensor: Center frequency adjustable from 45-65 Hz. Dropout bandwidth adjustable from 0.3-5% of center frequency beyond pickup bandwidth. Pickup bandwidth adjustable from 0.3-20% of center frequency. Field configurable to enable.

Loss of phase sensor: Detects out of range voltage phase angle relationship. Field configurable to enable.

Phase rotation sensor: Checks for valid phase rotation of source. Field configurable to enable.

Breaker tripped: If the breaker tripped input is active, the associated source will be considered as unavailable.

Timers: Control provides adjustable start delay from 0 - 300sec, stop delay from 0 - 800sec, transfer delay from 0-120sec, retransfer delay from 0-1800sec, programmed transition delay from 0-60sec, and maximum parallel time from 0-1800sec.

Negative Sequence Current Protection: PCC3300 supports this protection natively in order to determine if the generator is at any point was running subject to negative phase sequencing.

Breaker control – Utility and Genset breaker interfaces include separate relays for opening and closing breaker, as well as inputs for both 'a' and 'b' breaker position contacts and tripped status. Breaker diagnostics include Contact Failure, Fail to Close, Fail to Open, Fail to Disconnect, and Tripped. Upon breaker failure, appropriate control action is taken to maintain system integrity.

Exerciser clock –The exerciser clock (when enabled) allows the system to be operated at preset times in either test without load, test with load, or extended parallel mode. A Real Time Clock is built in. Up to 12 different programs can be set for day of week, time of day, duration, repeat interval, and mode. For example, a test with load for 1 hour every Tuesday at 2AM can be programmed. Up to 6 different exceptions can also be set up to block a program from running during a specific date and time period.

Extended paralleling – In extended paralleling mode (when enabled) the controller will start the genset and parallel to a utility source and then govern the real and reactive power output of the genset based on the desired control point. The control point for the real power (kW) can be configured for either the genset metering point ("Base Load") or the utility metering point ("Peak Shave"). The control point for the reactive power (kVAR or Power Factor) can also be independently configured for either the genset metering point or the utility metering point. This flexibility would allow base kW load from the genset while maintaining the utility power factor at a reasonable value to avoid

penalties due to low power factor. The System always operates within genset ratings. The control point can be changed while the system is in operation. Set points can be adjusted via hardwired analog input or adjusted through an operator panel display or service tool.

Application types – Controller is configured to operating in one of six possible application types. These topologies are often used in combinations in larger systems, with coordination of the controllers in the system either by external device or by interlocks provided in the control. Topologies that may be selected in the control include:

Standalone: Control provides monitoring, protection and control in a non-paralleling application.

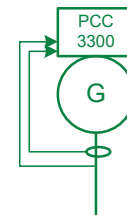

Synchronizer only: control will synchronize the genset to other source when commanded to either via a hardwired or Modbus driven input.

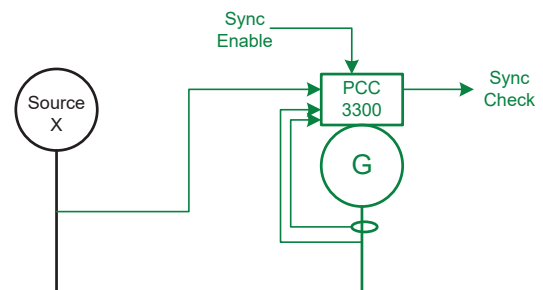

Isolated Bus: allows the genset to perform a dead bus closure or synchronize to the bus and isochronously share kW and kVAR loads with other gensets.

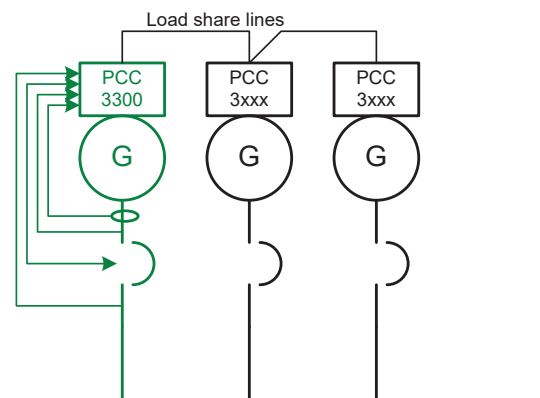

Utility Single: Control monitors one genset and utility. The control will automatically start and provide power to a load if the utility fails. The control will also resynchronize the genset back to the utility and provides extended paralleling capabilities.

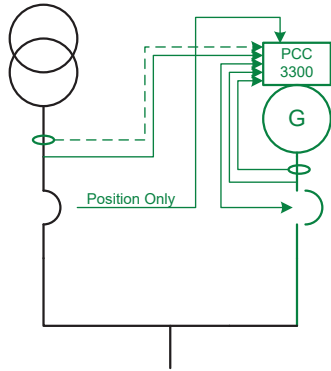

Utility Multiple: Supports all functionality of Isolated Bus and provides extended paralleling to the utility. Extended paralleling load set points follow a constant setting; dynamically follow an analog input, Modbus register or HMI.

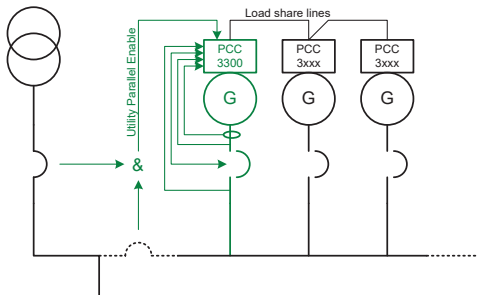

Power Transfer Control: Control operates a single genset/single utility transfer pair in open transition, fast closed transition, or soft closed transition. Extended paralleling functionality also provides base load and peak shave options.

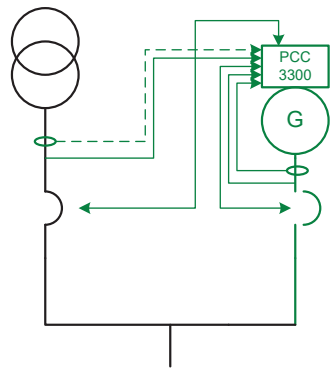

Masterless Load Demand (Optional Feature):

PowerCommand® 3.3 with Masterless Load Demand (MLD) technology enables generator sets to start/stop automatically based on load demand. Masterless Load Demand-capable generators are equipped with an additional s-CAN network connection that allows sharing of information amongst paralleled generator sets. MLD has been designed for hassle-free installation, commissioning and operation. MLD functionality. Integrated on-board system logic provides the MLD topology control without the need for any additional system.

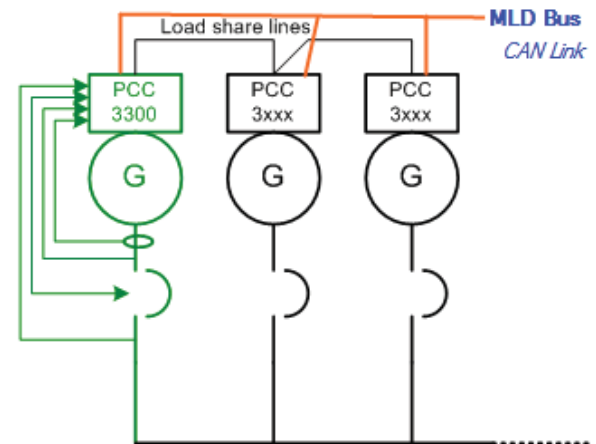
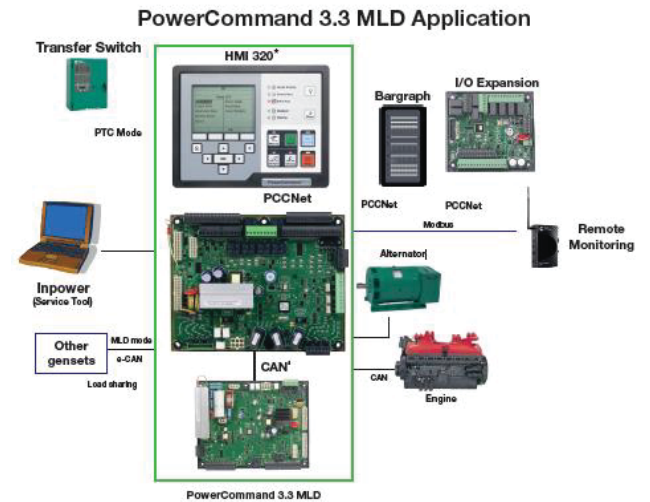

PCC3300 External Voltage and Frequency Biasing Inputs

PCC3300 supports externally driven voltage and frequency biasing capability in order to permit external paralleling (if intending to use this feature please contact your local distributor for further information).

Protective Functions

On operation of a protective function the control will indicate a fault by illuminating the appropriate status LED on the HMI, as well as display the fault code and fault description on the LCD. The nature of the fault and time of occurrence are logged in the control. The service manual and InPower service tool provide service keys and procedures based on the service codes provided. Protective functions include:

Battle short mode

When enabled and the *battle short* switch is active, the control will allow some shutdown faults to be bypassed. If a bypassed shutdown fault occurs, the fault code and description will still be annunciated, but the genset will not shutdown. This will be followed by a *fail to shutdown* fault. Emergency stop shutdowns and others that are critical for proper operation (or are handled by the engine ECM) are not bypassed. Please refer to the Control Application Guide or Manual for list of these faults.

Derate

The Derate function reduces output power of the genset in response to a fault condition. If a Derate command occurs while operating on an isolated bus, the control will issue commands to reduce the load on the genset via contact closures or Modbus. If a Derate command occurs while in utility parallel mode, the control will actively reduce power by lowering the base load kW to the derated target kW.

Configurable alarm and status inputs

The control accepts up to four alarm or status inputs (configurable contact closed to ground or open) to indicate a configurable (customer-specified) condition.

The control is programmable for warning, derate, shutdown, shutdown with cooldown or status indication and for labeling the input.

Emergency stop

Annunciated whenever either emergency stop signal is received from external switch.

General prime mover protection

Low and high battery voltage warning - Indicates status of battery charging system (failure) by continuously monitoring battery voltage.

Weak battery warning - The control system will test the battery each time the genset is signaled to start and indicate a warning if the battery indicates impending failure.

Low coolant level warning – Can be set up to be a warning or shutdown.

Low coolant temperature warning – Indicates that engine temperature may not be high enough for a 10 second start or proper load acceptance.

Fail to start (overcrank) shutdown - The control system will indicate a fault if the genset fails to start by the completion of the engine crank sequence.

Fail to crank shutdown - Control has signaled starter to crank engine but engine does not rotate.

Cranking lockout - The control will not allow the starter to attempt to engage or to crank the engine when the engine is rotating.

Fault simulation –The control in conjunction with InPower software, will accept commands to allow a technician to verify the proper operation of the control and its interface by simulating failure modes or by forcing the control to operate outside of its normal operating ranges. InPower also provides a complete list of faults and settings for the protective functions provided by the controller.

For Lean Burn Natural Gas Engine applications:

Off load running (protection) – This feature protects the engine in the event the genset is being called to go off load for too long.

Hydro Mechanical fuel system engine protection:

Overspeed shutdown – Default setting is 115% of nominal

Low lube oil pressure warning/shutdown – Level is preset (configurable with InPower or HMI) to match the capabilities of the engine used. Control includes time delays to prevent nuisance alarms.

High lube oil temperature warning/shutdown – Level is preset (configurable with InPower or HMI) to match the capabilities of the engine used. Control includes time delays to prevent nuisance alarms.

High engine temperature warning/shutdown – Level is preset (configurable with InPower or HMI) to match the capabilities of the engine used. Control includes time delays to prevent nuisance alarms.

Low coolant temperature warning – Indicates that engine temperature may not be high enough for a 10 second start or proper load acceptance.

High intake manifold temperature shutdown – Level is preset (configurable with InPower or HMI) to match the capabilities of the engine used. Control includes time delays to prevent nuisance alarms.

Full authority electronic engine protection:

Engine fault detection is handled inside the engine ECM. Fault information is communicated via the SAE-J1939 data link for annunciation in the HMI.

Alternator Protection

AmpSentry protective relay - A comprehensive monitoring and control system integral to the PowerCommand® Control System that guards the electrical integrity of the alternator and power system by providing protection against a wide array of fault conditions in the genset or in the load. It also provides single and three phase fault current regulation (3x Current) so that downstream protective devices have the maximum current available to quickly clear fault conditions without subjecting the alternator to potentially catastrophic failure conditions. Thermal damage curve (3 phase short) or fixed timer (2sec for 1P short, 5sec for 2P short). See document R1053 for a full-size time over current curve. The control does not include protection required for interconnection to a utility (mains) service.

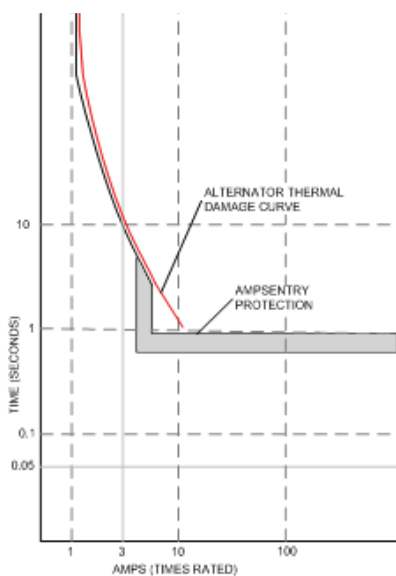

AmpSentry Maintenance Mode (AMM) - Instantaneous tripping, if AmpSentry Maintenance mode is active (50mS response to turn off AVR excitation/shutdown genset) for arc flash reduction when personnel are near genset.

High AC voltage shutdown (59) - Output voltage on any phase exceeds preset values. Time to trip is inversely proportional to amount above threshold. Values adjustable from 105-125% of nominal voltage, with time delay adjustable from 0.1-10 seconds. Default value is 110% for 10 seconds.

Low AC voltage shutdown (27) - Voltage on any phase has dropped below a preset value. Adjustable over a range of 50-95% of reference voltage, time delay 2-20 seconds. Default value is 85% for 10 seconds. Function tracks reference voltage. Control does not nuisance trip when voltage varies due to the control directing voltage to drop, such as during a V/Hz roll-off or synchronizing.

Under frequency shutdown (81 u) - Genset output frequency cannot be maintained. Settings are adjustable from 2-10 Hz below reference governor set point, for a 5-20 second time delay. Default: 6 Hz, 10 seconds. Under frequency protection is disabled when excitation is switched off, such as when engine is operating in idle speed mode.

Over frequency shutdown/warning (81o) - Genset is operating at a potentially damaging frequency level. Settings are adjustable from 2-10 Hz above nominal governor set point for a 1-20 second time delay. Default: 6 Hz, 20 seconds, disabled.

Overcurrent warning/shutdown (51) - Implementation of the thermal damage curve with instantaneous trip level calculated based on current transformer ratio and application power rating.

Loss of sensing voltage shutdown - Shutdown of genset will occur on loss of voltage sensing inputs to the control.

Field overload shutdown - Monitors field voltage to shutdown genset when a field overload condition occurs.

Over load (kW) warning - Provides a warning indication when engine is operating at a load level over a set point. Adjustment range: 80-140% of application rated kW, 0-120 second delay. Defaults: 105%, 60 seconds.

Reverse power shutdown (32) - Adjustment range: 5-20% of standby kW rating, delay 1-15 seconds. Default: 10%, 3 seconds.

Reverse Var shutdown (40) - Shutdown level is adjustable: 15-50% of rated Var output, delay 10-60 seconds. Default: 20%, 10 seconds.

Short circuit protection - Output current on any phase is more than 175% of rating and approaching the thermal damage point of the alternator. Control includes algorithms to protect alternator from repeated over current conditions over a short period of time.

Negative sequence overcurrent warning (46) - Control protects the generator from damage due to excessive imbalances in the three phase load currents and/or power factors.

Custom overcurrent warning/shutdown (51) - Control provides the ability to have a custom time overcurrent protection curve in addition to the AmpSentry protective relay function.

Ground fault overcurrent (51G) - Control detects a ground fault either by an external ground fault relay via a contact input or the control can measure the ground current from an external current transformer. Associated time delays and thresholds are adjustable via InPower or HMI.

Paralleling Protection

Breaker fail to close Warning: When the control signals a circuit breaker to close, it will monitor the breaker auxiliary contacts and verify that the breaker has closed. If the control does not sense a breaker closure within an adjustable time period after the close signal, the fail to close warning will be initiated.

Breaker fail to open warning: The control system monitors the operation of breakers that have been signaled to open. If the breaker does not open within an adjustable time delay, a Breaker Fail to Open warning is initiated.

Breaker position contact warning: The controller will monitor both 'a' and 'b' position contacts from the breaker. If the contacts disagree as to the breaker position, the breaker position contact warning will be initiated.

Breaker tripped warning: The control accepts inputs to monitor breaker trip / bell alarm contact and will initiate a breaker tripped warning if it should activate.

Fail to disconnect warning: In the controller is unable to open either breaker, a fail to disconnect warning is initiated. Typically, this would be mapped to a configurable output, allowing an external device to trip a breaker.

Fail to synchronize warning: Indicates that the genset could not be brought to synchronization with the bus. Configurable for adjustable time delay of 10 -900 seconds, 120 default.

Phase sequence sensing warning: Verifies that the genset phase sequence matches the bus prior to allowing the paralleling breaker to close.

Maximum parallel time warning (power transfer control mode only): During closed transition load transfers, control independently monitors paralleled time. If time is exceeded, warning is initiated and genset is disconnected.

Bus or genset PT input calibration warning: The control system monitors the sensed voltage from the bus and genset output voltage potential transformers. When the paralleling breaker is closed, it will indicate a warning condition if the read values are different.

Field Control Interface

Input signals to the PowerCommand® control include:

- Coolant level (where applicable)
- Fuel level (where applicable)
- Remote emergency stop
- Remote fault reset
- Remote start
- Rupture basin
- Start type signal
- Battle short
- Load demand stop
- Synchronize enable
- Genset circuit breaker inhibit
- Utility circuit breaker inhibit
- Single mode verify
- Transfer inhibit – prevent transfer to utility (in power transfer control mode)
- Retransfer inhibit – prevent retransfer to genset (in power transfer control mode)
- kW and kVAR load setpoints

Configurable inputs - Control includes (4) input signals from customer discrete devices that are configurable for warning, shutdown or status indication, as well as message displayed

Input signals for Lean Burn Natural Gas Engine applications:

- Gearbox oil pressure/temperature protection
- Fire fault
- Earth fault support as a discrete input via an appropriate secondary detection device
- Differential fault
- DC power supply fault
- Genset Interface Box (GIB) isolator open fault
- Start inhibit/enable (x3)
- Radiator fan trip
- Ventilator fan trip
- Ventilation louvers closed
- Start system trip
- Alternator heater trip
- Alternator heater status
- Alternator winding temperature (PT100 RTDx3)
- Alternator drive end bearing temperature (PT100 RTD)
- Alternator non-drive end bearing temperature (PT100 RTD)

Output signals from the PowerCommand® control include:

- Load dump signal: Operates when the genset is in an overload condition.
- Delayed off signal: Time delay-based output which will continue to remain active after the control has removed the run command. Adjustment range: 0 - 120 seconds. Default: 0 seconds.

- Configurable relay outputs: Control includes (4) relay output contacts (3 A, 30VDC). These outputs can be configured to activate on any control warning or shutdown fault as well as ready to load, not in auto, common alarm, common warning and common shutdown.
- Ready to load (genset running) signal: Operates when the genset has reached 90% of rated speed and voltage and latches until genset is switched to off or idle mode.
- Paralleling circuit breaker relays outputs: Control includes (4) relay output contacts (3.5A, 30 VDC) for opening and closing of the genset and utility breakers.

Output Signals for Lean Burn Natural Gas Engine applications:

- Start inhibit/enable event
- Emergency stop event
- Ventilator fan run control
- Louvre control
- Radiator fan control
- Alternator heater control
- Engine at idle speed event

Communications connections include:

- PC tool interface: This RS-485 communication port allows the control to communicate with a personal computer running InPower software.
- Modbus RS-485 port: Allows the control to communicate with external devices such as PLCs using Modbus protocol.

Note - An RS-232 or USB to RS-485 converter is required for communication between PC and control.

- Networking: This RS-485 communication port allows connection from the control to the other Cummins Power Generation products.

Mechanical Drawing

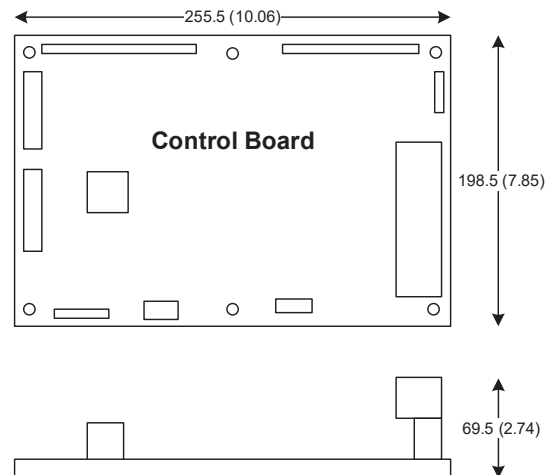

PowerCommand® Human Machine Interface HMI320



Description

This control system includes an intuitive operator interface panel that allows for complete genset control as well as system metering, fault annunciation, configuration and diagnostics. The interface includes five genset status LED lamps with both internationally accepted symbols and English text to comply with customer's needs. The interface also includes an LED backlit LCD display with tactile feel soft-switches for easy operation and screen navigation. It is configurable for units of measurement and has adjustable screen contrast and brightness.

The run/off/auto switch function is integrated into the interface panel.

All data on the control can be viewed by scrolling through screens with the navigation keys. The control displays the current active fault and a time-ordered history of the five previous faults.

Features:

- LED indicating lamps
 - genset running
 - remote start
 - not in auto
 - shutdown
 - warning
 - auto
 - manual and stop
 - Circuit breaker open (if equipped)
 - Circuit breaker closed (if equipped)
- 320 x 240 pixels graphic LED backlight LCD.
- Four tactile feel membrane switches for LCD defined operation. The functions of these switches are defined dynamically on the LCD.
- Seven tactile feel membrane switches dedicated screen navigation buttons for up, down, left, right, ok, home and cancel.

- Six tactile feel membrane switches dedicated to control for auto, stop, manual, manual start, fault reset and lamp test/panel lamps.
- Two tactile feel membrane switches dedicated to control of circuit breaker (where applicable).
- Allows for complete genset control setup.
- Certifications: Suitable for use on gensets that are designed, manufactured, tested and certified to relevant UL, NFPA, ISO, IEC, Mil Std., UKCA and CE standards.
- Languages supported: English, Spanish, French, German, Italian, Greek, Portuguese, Finnish, Norwegian, Danish, Russian (Cyrillic), Chinese, Hungarian, Japanese, Polish, Korean, Romanian, Brazilian Portuguese, Turkish, Dutch, and Czech

Communications connections include:

- PC tool interface - This RS-485 communication port allows the HMI to communicate with a personal computer running InPower.
- This RS-485 communication port allows the HMI to communicate with the main control board.

Mechanical Drawing

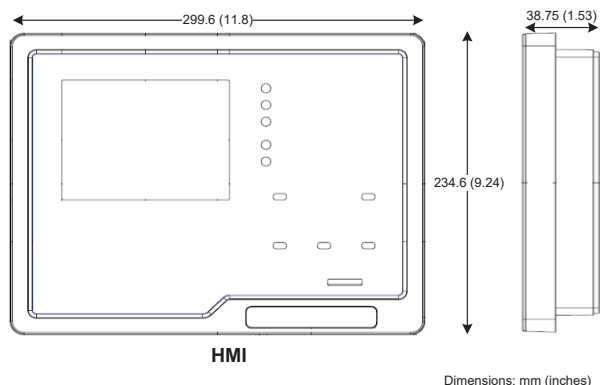

Software

InPower (beyond 6.5 version) is a PC-based software service tool that is designed to directly communicate to PowerCommand® gensets and transfer switches, to facilitate service and monitoring of these products.

Environment

The control is designed for proper operation without recalibration in ambient temperatures from -40 °C (-40 °F) to +70° C (158 °F), and for storage from -55 °C (-67 °F) to +80 °C (176 °F). Control will operate with humidity up to 95%, non-condensing.

The HMI is designed for proper operation in ambient temperatures from -20 °C (-4 °F) to +70 °C (158 °F), and for storage from -30 °C (-22 °F) to +80 °C (176 °F).

The control board is fully encapsulated to provide superior resistance to dust and moisture. Display panel has a single membrane surface, which is impervious to effects of dust, moisture, oil and exhaust fumes. This panel uses a sealed membrane to provide long reliable service life in harsh environments.

The control system is specifically designed and tested for resistance to RFI/EMI and to resist effects of vibration to provide a long reliable life when mounted on a genset. The control includes transient voltage surge suppression to provide compliance to referenced standards.

Certifications

PowerCommand® meets or exceeds the requirements of the following codes and standards:

- NFPA 110 for level 1 and 2 systems.
- ISO 8528-4:2005 compliance, controls and switchgear (second edition)
- CE marking: The CE marking is only valid when equipment is used in a fixed installation application. Material compliance declaration is available upon request.
- UKCA marking- The UKCA marking is only valid when equipment is used in a fixed installation application. Material compliance declaration is available upon request.
- EN 50081-1,2 residential/light industrial emissions or industrial emissions.
- EN 50082-1,2 residential/light industrial or industrial susceptibility.
- ISO 7637-2, level 2; DC supply surge voltage test.
- Mil Std 202C, Method 101 and ASTM B117: Salt fog test.
- UL 6200 recognized, suitable for use on UL 2200 Listed generator sets.
- CSA C282-M1999 compliance
- CSA 22.2 No. 14 M91 industrial controls.
- PowerCommand® control systems and generator sets are designed and manufactured in ISO 9001 certified facilities.
- ROHS (Restriction of Hazardous substance) complaint both for HMI 320 & PCC3300v2.

Reference Documents

Please refer to the following reference documents available in the PowerSuite library:

- PowerCommand™ 3.3. Application Guide
- T-037: PowerCommand Control Application Manual (ANSI Protective Functions)
- T-040: PowerCommand 3.3 Paralleling Application Guide

Please refer to the following reference documents available on Cummins Quickserve:

- Service Manuals for PC3.3 (non-MLD) and PC3.3 (MLD)
- Modbus Register Mapping

Warranty

All components and subsystems are covered by an express limited one-year warranty. Other optional and extended factory warranties and local distributor maintenance agreements are available.





OUTDOOR ENCLOSURE

Accessory specification sheet for 250 - 1300 kW Natural gas generator sets (GenSets)

THE RIGHT CHOICE FOR GENSET PROTECTION.

Cummins provides the option of protecting your Cummins Generator Set (GenSet) with UL 2200 Listed weather-protective and sound-attenuated steel enclosures that not only limit the GenSet from producing high decibels of sound, but also protect the GenSet from harsh weather conditions. These enclosures are designed to enclose the entire GenSet while allowing ample air flow for cooling. Several enclosure configurations are available for each GenSet model to suit most weather protection and sound control requirements:



Weather-protective enclosures provide protection from climate conditions and include an internally-mounted exhaust silencer. The exhaust silencer on a weather-protective enclosure reduces noise, but is primarily intended to protect the GenSet from the outdoor environment.

Level I sound-attenuated enclosures provide weather protection and include an internally-mounted exhaust silencer and sound insulating panels. The silencer and the panels reduce the noise level of the GenSet to a level below that achieved with a weather protective enclosure. Level I sound-attenuated enclosures are appropriate for applications where sound reducing enclosures are required.

Level II sound-attenuated enclosures provide weather protection and include an internally-mounted exhaust silencer and sound insulating panels which reduce the noise level of the GenSet to a level below that achieved with a Level I sound-attenuated enclosure. Level II sound-attenuated enclosures are appropriate for applications where sound reducing enclosures are required.

NOTE: Enclosures are designed for outdoor use, only.

Enclosure feature	Standard	Optional
Construction	Galvannealed steel	Aluminum (for corrosive environments)
	Compact footprint	Manufactured floor
	Stainless steel hardware	
	Cambered roof to prevent water accumulation	
	Zinc phosphate pretreatment, e-coat primer, and super durable textured powder topcoat paint to help minimize corrosion and color fade	
	Rain collar and rain cap	
Intake and discharge louvers	Fixed	Motorized intake
		Motorized or gravity discharge
Doors	Two or three (depending on the GenSet dimensions) flush, recessed, and hinged doors per side for service access	
	Doors keyed alike for added security and convenience	
	Weather-protective bulb seals	
Silencer grade	Critical	Hospital
Silencer construction	Stainless steel	Aluminum
Installation	Enclosure directly attached to the GenSet skid base; easy access lifting points	
Wind rating	100 mph	High wind bracing
Electrical	Fuel and electrical stub-up area within enclosure perimeter	
Accessories		DC lights w/timer (2)
		120/240V load center 120/208V load center
		AC lights (2 X AC vapor-proof)
		120V GFI convenience receptacles (2)
		5 kW heater
		External emergency-stop

Level I and Level II sound-attenuated enclosures

For detailed sound data, refer to the GenSet sound data sheet.

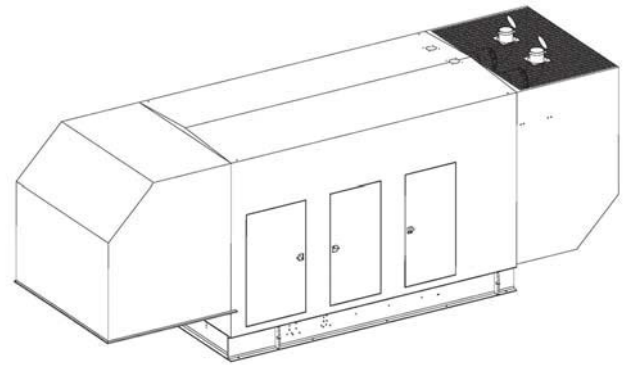

Level I and Level II sound-attenuated enclosure dimensions and weights

GenSet model	GenSet sound data sheet	Length in. (cm)	Width in. (cm)	Height in. (cm)	Steel weight lbs. (kg)	Aluminum weight lbs. (kg)
C250N6	MSP-4054	281 (714)	70 (178)	99 (251)	2550 (1157)	1530 (694)
C300N6	MSP-4056	281 (714)	70 (178)	99 (251)	2550 (1157)	1530 (694)
C350N6	MSP-4057	281 (714)	70 (178)	94 (239)	2550 (1157)	1530 (694)
C400N6	MSP-4059	305 (775)	90 (229)	126 (320)	3600 (1633)	2160 (980)
C450N6	MSP-4060	305 (775)	90 (229)	126 (320)	3600 (1633)	2160 (980)
C500N6B	MSP-4061	305 (775)	90 (229)	126 (320)	3600 (1633)	2160 (980)
C550N6	MSP-4062	340 (864)	102 (259)	132 (335)	4400 (1996)	2640 (1197)
C600N6	MSP-4063	365 (927)	102 (259)	128 (325)	5100 (2313)	3060 (1388)
C650N6	MSP-4065	365 (927)	102 (259)	128 (325)	5100 (2313)	3060 (1388)
C750N6	MSP-4067	365 (927)	102 (259)	128 (325)	5100 (2313)	3060 (1388)
C1000N6B	MSP-4070	403 (1024)	102 (259)	131 (333)	5750 (2608)	3450 (1565)
C1300N6	MSP-4071	403 (1024)	102 (259)	131 (333)	5750 (2608)	3450 (1565)

Enclosure paint options

These standard enclosure colors are available as selected in Cummins pricing. All GenSet enclosures will be painted Onan Green Textured, unless otherwise ordered. Underwriters Laboratories (UL) colors noted are included in standard pricing; other colors selected for UL units would have additional charges. Contact your local sales representative for more information.



Onan Green Textured (UL)



Moss Green



Cream

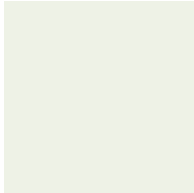

Sugar White



Cummins Red



Cummins Beige (UL)



Chocolate Brown

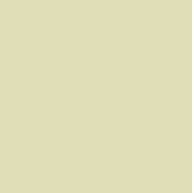

Compartment Tan
Textured (UL)



Spectrum Gray



ANSI 61 Gray (UL)



Jet Black

Applicable codes and standards



The Underwriters Laboratory (UL) 2200 Listing is a comprehensive safety standard encompassing the design, construction, and performance of stationary GenSets.



CSA Group tests products under a formal process to ensure that they meet the safety and/or performance requirements of applicable standards. This GenSet is certified to: CSA 22.2 No. 100 Motors and Generators; CSA 22.2 No. 0.4-044 Bonding of Electrical Equipment; CSA 22.2 No. 14 Industrial Control Equipment; and CSA 22.2 No. 0 General Requirements - Canadian Electrical Code, Part II. All low voltage models are CSA-certified to product class 4215-01.

ISO 9001:2015

This product has been manufactured under the controls established by an approved management system that conforms with ISO 9001:2015.

GenSets with weather-protective or sound-attenuated enclosures may reduce the ambient temperature of the GenSet by 4 to 8 °F (2 to 4.5 °C) depending on the type of enclosure and site conditions. Refer to the GenSet specification sheet and the cooling data sheet for specific capabilities.



Cummins Inc.
Box 3005
Columbus, IN 47202-3005
U.S.A.

1-800-CUMMINS™ (1-800-286-6467)
cummins.com

Printed in U.S.A.
©2023 Cummins Inc.



2024 EPA Exhaust Emission Compliance Statement C1300N6 60 Hz Spark Ignited Generator Set

Compliance Information:

The engine used in this generator set meets U.S. EPA emission limits under 40 CFR Part 60 and 1048 (Stationary and Mobile).

Engine Manufacturer:	Cummins Inc.
EPA Certificate Number:	RCEXB60.0AAA-015
Effective Date:	12/28/2023
Date Issued:	12/28/2023
EPA Engine Family (Cummins Emissions Family):	RCEXB60.0AAA

Engine Information:

Model:	QSK60G/QSK60-G8	Bore:	6.26 in. (159 mm)
Engine Nameplate HP:	1953	Stroke:	7.48 in. (190 mm)
Type:	4 Cycle, Vee, 16 Cylinder, Lean Burn Natural Gas	Displacement:	3671.0 cu. in. (60 liters)
Aspiration:	Turbocharged and Aftercooled	Compression Ratio:	11.4:1
Emission Control Device:	Turbocharged and Aftercooled	Exhaust Stack Diameter:	8.0 in (203 mm)

U.S. Environmental Protection Agency SI Emission Limits

Lean Burn Gas: Stationary Part 60	Grams per BHP-hr			Grams per kWm-hr		
	NOx	CO	VOC	NOx	CO	VOC
EPA Emissions Limit	1.0	2.0	0.7	1.3	2.7	0.9

Notes:

Tests conducted using alternate methods, instrumentation, fuel or reference conditions can yield different results.

Engine operation with excessive air intake or exhaust restriction beyond published maximum limits, or with improper maintenance, may result in elevated emission levels.



Exhaust emission data sheet C1300N6 60 Hz spark-ignited generator set (GenSet)

Natural gas exhaust emissions data @ 1800 rpm

Exhaust component		50% load		75% load		Full load	
		g/hp-hr	ppm	g/hp-hr	ppm	g/hp-hr	ppm
Oxides of nitrogen (as NO _x , DRY)	NO _x	1.0	150	1.0	155	1.0	158
Total hydrocarbons (WET)	THC	1.0	3.7	3.8	1484	3.4	1357
Carbon Monoxide (DRY)	CO	N/A	N/A	1.7	405	1.6	406

Engine information:

Model:	Cummins QSK60G	Bore:	6.25 in. (159 mm)
Emission certification:	EPA-certified for stationary emergency and non-emergency applications	Stroke:	7.48 in. (190 mm)
Aspiration:	Turbocharged and coolant-air aftercooled	Displacement:	3672 in ³ (60 L)
		Cylinders:	16
		Combustion:	Advanced lean burn
		Compression ratio:	11.4:1

Test conditions

Steady-state emissions recorded per ISO 8178-1 during operation at rated engine speed (+/- 2%) and stated constant load (+/- 2%) with engine temperatures, pressures, and emission rates stabilized.

Fuel specifications:	Dry processed natural gas fuel with 905 BTU per standard cubic foot lower heating value. The percentage of NMHCs found in exhaust emissions are typically 2-3 times the percentage of NMHCs found in fuel. If there is no NMHC in the fuel, NMHC and VOC emissions in exhaust will be insignificant.
Air inlet temperature:	77 °F (25 °C)
Barometric pressure:	29.39 in. Hg (99.5 kPa) at 500 ft. (152 m) altitude
Relative humidity:	30%
Emissions data tolerance:	NO _x : +/-10%, HC: +/-15%, CO: +/-10%

The NO_x, HC, CO and particulate matter (PM) emissions data tabulated here are representative of test data taken from a single engine under the test conditions shown above. These data are subjected to instrumentation and engine-to-engine variability. Field emission test data are not guaranteed to these levels. Actual field test results may vary due to engine tuning, test site conditions, installation, fuel specification, test procedures, and instrumentation. Engine operation with excessive air intake or exhaust restrictions beyond published maximum limits, or with improper maintenance, may result in elevated emissions levels.



Sound data sheet

C1300N6 60 Hz spark-ignited generator set (GenSet)

Sound pressure levels (SPLs) with radiator cooling package

A-weighted SPLs in dB(A) @ 7 meters

GenSet configuration	Applied standby load	Microphone position*								8 position average SPL	*Position 1 faces the GenSet front. The positions proceed around the GenSet in a counter-clockwise direction in 45° increments. All positions are approximately 7 m (23 ft.) from the surface of the GenSet and approximately 1.2 m (48 in) from floor level.
		1	2	3	4	5	6	7	8		
Unhoused with infinite exhaust	No load	87.8	93.1	92.6	95.8	93.1	93.8	94.3	93.3	93.4	
	50% load	88.2	93.4	93.0	95.9	93.0	93.9	94.5	93.5	93.6	
	75% load	88.8	93.9	93.5	96.1	92.9	94.1	94.9	93.9	93.9	
	Full load	89.9	94.8	94.4	96.4	92.7	94.6	95.4	94.2	94.4	
Housed with level II sound-attenuated enclosure and muffler	No load	84.4	85.9	81.9	83.3	82.6	81.6	78.4	85.0	83.4	
	50% load	84.1	85.8	82.1	83.1	82.2	80.9	78.5	84.4	83.1	
	75% load	84.0	85.7	82.4	83.2	82.3	80.9	78.8	84.3	83.1	
	Full load	84.5	86.1	83.2	83.8	82.8	81.5	79.8	84.7	83.7	

Average A-weighted SPLs in dB(A) @ 1 meter

measured from a reference parallelepiped creating a hemisphere around the GenSet

GenSet configuration	Applied standby load	Octave band center frequency, Hz											Total SPL
		16	32	63	125	250	500	1000	2000	4000	8000	16000	
Unhoused with infinite exhaust	No load	N/A	51.3	71.1	91.5	93.5	95.2	94.6	92.2	88.1	81.7	68.6	100.9
	50% load	N/A	51.6	71.2	91.6	93.6	95.3	94.7	92.7	88.5	83.4	69.8	101.1
	75% load	N/A	51.6	71.3	91.6	93.6	95.3	94.9	93.5	89.0	86.4	71.7	101.4
	Full load	N/A	51.8	71.4	91.8	93.7	95.4	95.5	94.6	89.9	89.4	73.3	101.9
Housed with level II sound-attenuated enclosure and muffler	No load	N/A	49.3	65.2	88.2	86.2	84.3	79.9	79.1	73.2	67.0	53.0	91.9
	50% load	N/A	49.4	65.5	87.8	86.4	84.5	80.3	80.0	74.4	68.1	56.5	92.0
	75% load	N/A	51.6	65.5	87.5	86.4	85.0	81.3	81.0	76.1	70.9	63.0	92.2
	Full load	N/A	53.9	66.8	87.5	86.9	86.8	84.1	82.9	78.2	73.4	65.0	93.2

A-weighted SPLs in dB(A) @ the operator location

measured at 1 meter from the GenSet control panel at 1.5 meter height

GenSet configuration	Applied standby load	Octave band center frequency, Hz											Total SPL
		16	32	63	125	250	500	1000	2000	4000	8000	16000	
Unhoused with infinite exhaust	75% load	N/A	52.0	72.6	86.4	91.8	96.6	97.4	96.4	89.5	86.8	73.4	102.5
	Full load	N/A	52.1	72.5	86.6	92.1	96.9	97.9	97.7	90.6	89.9	75.9	103.2
Housed with level II encl and muffler	75% load	N/A	46.9	66.7	87.4	81.4	80.0	74.0	76.7	67.7	69.3	62.3	89.4
	Full load	N/A	47.0	67.2	87.1	81.7	80.2	75.0	78.9	69.2	72.4	64.3	89.6

Sound power levels (SPWLs) with radiator cooling package

A-weighted SPWLs in dB(A) @ 1 meter

measured from a reference parallelepiped creating a hemisphere around the GenSet

GenSet configuration	Applied standby load	Octave band center frequency, Hz											Total SPWL
		16	32	63	125	250	500	1000	2000	4000	8000	16000	
Unhoused with infinite exhaust	No load	N/A	72.5	92.3	112.7	114.7	116.4	115.8	113.4	109.3	102.9	89.8	122.1
	50% load	N/A	72.8	92.4	112.8	114.8	116.5	115.9	113.9	109.7	104.6	91.0	122.3
	75% load	N/A	72.8	92.5	112.8	114.8	116.5	116.1	114.7	110.2	107.6	92.9	122.6
	Full load	N/A	73.0	92.6	113.0	114.9	116.6	116.7	115.8	111.1	110.6	94.5	123.1
Housed with level II sound-attenuated enclosure and muffler	No load	N/A	72.3	88.2	111.2	109.2	107.3	102.9	102.1	96.2	90.0	76.0	114.9
	50% load	N/A	72.4	88.5	110.8	109.4	107.5	103.3	103.0	97.4	91.1	79.5	115.0
	75% load	N/A	74.6	88.5	110.5	109.4	108.0	104.3	104.0	99.1	93.9	86.0	115.2
	Full load	N/A	76.9	89.8	110.5	109.9	109.8	107.1	105.9	101.2	96.4	88.0	116.2

A-weighted exhaust SPWLs in dB(A) @ 1 meter

measured 1 meter from the exhaust termination

GenSet configuration	Applied standby load	Octave band center frequency, Hz											Total SPWL
		16	32	63	125	250	500	1000	2000	4000	8000	16000	
Unhoused open exhaust with tail pipe	No load	N/A	65.3	88.0	106.9	111.4	108.1	96.4	93.5	83.1	76.2	59.6	114.1
	50% load	N/A	60.0	90.5	110.0	112.0	113.8	108.6	106.5	104.5	102.1	87.4	118.2
	75% load	N/A	62.9	93.0	111.7	115.3	118.2	114.8	114.0	113.3	108.5	101.7	123.0
	Full load	N/A	62.6	92.6	114.1	115.0	117.8	116.0	115.0	114.6	110.2	103.7	123.6

Published sound levels are measured at a CE certified test site and are subject to instrumentation measurement, installation, and manufacturing variability. The reference SPL is 20 μ Pa. The reference SPWL is 1 pW (10^{-12} W). SPLs and SPWLs at 1 meter from a reference parallelepiped creating a hemisphere around the GenSet are measured per the requirements of ISO 3744 and ISO 8528-10. Exhaust SPWLs at 1 meter are calculated per ISO 6798, Annex A.

An unhoused (open set) configuration GenSet refers to a GenSet with no sound enclosure of any kind. A housed (closed set) configuration GenSet refers to a GenSet that has a Level II (noise reduction) sound enclosure installed over the GenSet. The Level II enclosure is integrally attached to the skid base of the GenSet.

The sound data for a GenSet with infinite exhaust does not include the exhaust noise contribution. The exhaust sound data for a GenSet is solely exhaust noise and does not include noise from any other noise sources.



Prototype test report 60 Hz test summary

Applicable generator set models:
C1300N6 (1300 kW)

Representative prototype:
Model: C1300N6 (1300 kW)
Engine: QSK 60G
Alternator: PI734C

The following summarizes prototype testing conducted on the designated representative prototype of the specified models. This testing is conducted to verify the complete generator set (GenSet) electrical and mechanical design integrity.

Cooling system

40 °C ambient
0.5 in. H₂O restriction

The cooling system was tested to determine ambient temperature and static restriction capabilities. The test was performed at full rated load under static restriction conditions.

Alternator temperature rise

The highest rated temperature rise (120 °C) test results are reported as follows to verify that worst case temperature rises do not exceed allowable NEMA MG1 limits for Class H insulation. Tests were conducted per IEEE 115, rise by resistance and embedded detector, with rated voltages. Only the highest temperatures are reported.

Durability

The GenSet was subject to an endurance test operating at variable load up to the standby rating to verify structural soundness and durability of the design.

Electrical and mechanical strength

The GenSet was tested to several single-phase and three-phase faults to verify that the generator can safely withstand the forces associated with short circuit conditions. The GenSet was capable of producing full rated output at the conclusion of the testing.

Torsional analysis and testing

The GenSet was tested to verify that the design is not subjected to harmful torsional stresses in excess of 5000 psi. A spectrum analysis of the transducer output was conducted over the speed range of 1650 to 1890 RPM.

Steady state performance

The GenSet was tested to verify steady state operating performance. It was within these specified maximum limits:

Voltage regulation:	±0.50%
Random voltage variation:	±0.50%
Frequency regulation:	Isochronous
Random frequency variation:	±0.50%

Transient performance

The GenSet was tested with the listed alternator to verify single step loading capability as required by NFPA 110. Voltage and frequency response on load addition or rejection were evaluated. The following results were recorded at 0.8 power factor:

Voltage dip:	23.0%
Recovery time:	4.2 seconds
Frequency dip:	16.3%
Recovery time:	6.0 seconds
Voltage rise:	11.7%
Recovery time:	0.5 seconds
Frequency rise:	6.5%
Recovery time:	2.6 seconds

Harmonic analysis

Harmonic	Line to line		Line to neutral	
	No load	Ful load	No load	Full load
3	0.18	0.02	0.13	0.08
5	0.2	2.0	0.13	1.99
7	0.52	1.46	0.48	0.74
9	0.08	0.03	0.03	0.07
11	0.65	0.48	0.64	0.46
13	0.21	0.28	0.19	0.31
15	0.05	0.05	0.03	0.1



Cooling system data sheet

C1300N6 60 Hz spark-ignited generator set (GenSet)

40 °C ambient radiator cooling system

	Rating (kW)	Maximum allowable ambient temperature, °C							
		Unhoused maximum cooling @ air flow static restriction by in. H ₂ O (mm H ₂ O)					Housed in free air (no air discharge restriction) by enclosure feature code		
		0.0 (0.0)	0.25 (6.4)	0.5 (12.7)	0.75 (19.1)	1.0 (25.4)	F265	F266	F267
Standby and demand response	1300	N/A	N/A	43	N/A	N/A	N/A	N/A	42

Data reflects anticipated cooling performance for a typical GenSet.
 Cooling data is based on 1000 ft. (305 m) site test location.
 GenSet power output may need to be reduced at high ambient conditions. Consult GenSet data sheet for derate schedules.
 Cooling performance may be reduced due to several factors including, but not limited to: incorrect installation; improper operation; fouling of the cooling system; and/or other site installation variables.



Alternator Data Sheet Frame Size: S7L1D-C4

Characteristics									
		No of Bearings:		1-bearing		2-bearing			
Weights:		Stator assembly:		2835 lb	1286 kg	2835 lb	1286 kg		
		Rotor assembly:		2542 lb	1153 kg	2440 lb	1107 kg		
		Complete assembly:		6415 lb	2910 kg	6358 lb	2884 kg		
Maximum speed:				2250 rpm					
Excitation current:		Full load:		Wdg 07: 2.6, Wdg 13: 2.5, Wdg 312: 2.8					
		No load:		Wdg 07: 0.93, Wdg 13: 1.1, Wdg 312: 0.61-0.58					
Insulation system:		Class H throughout							
3 Ø Ratings (0.8 power factor)			60 Hz (winding no)						
			<u>600</u>	<u>380</u>	<u>400</u>	<u>416</u>	<u>416</u>	<u>440</u>	<u>480</u>
			(07)	(13)	(13)	(13)	(312)	(312)	(312)
163° C rise ratings	@ 27° C	kW	1620	1520	1520	1520	1456	1556	1620
		kVA	2025	1900	1900	1900	1820	1945	2025
150° C rise ratings	@ 40° C	kW	1580	1485	1485	1485	1420	1515	1580
		kVA	1975	1856	1856	1856	1775	1894	1975
125° C rise ratings	@ 40° C	kW	1515	1425	1425	1425	1365	1455	1515
		kVA	1894	1781	1781	1781	1706	1819	1894
105° C rise ratings	@ 40° C	kW	1410	1325	1325	1325	1275	1355	1410
		kVA	1762	1656	1656	1656	1594	1694	1762
80° C rise ratings	@ 40° C	kW	1300	1225	1225	1225	1175	1255	1300
		kVA	1625	1531	1531	1531	1469	1569	1625
3 Ø Reactances			<u>600</u>	<u>380</u>	<u>400</u>	<u>416</u>	<u>416</u>	<u>440</u>	<u>480</u>
(Based on full load at 125° C rise rating)			(07)	(13)	(13)	(13)	(312)	(312)	(312)
Synchronous			2.01	1.80	1.62	1.50	3.35	3.19	2.79
Transient			0.19	0.20	0.18	0.16	0.26	0.24	0.21
Subtransient			0.12	0.14	0.13	0.12	0.16	0.16	0.14
Negative sequence			0.16	0.17	0.15	0.14	0.23	0.22	0.19
Zero sequence			0.02	0.02	0.02	0.02	0.03	0.03	0.03
3 Ø Motor starting			<u>600</u>	<u>380</u>	<u>400</u>	<u>416</u>	<u>416</u>	<u>440</u>	<u>480</u>
Maximum kVA (90% sustained voltage)			(07)	(13)	(13)	(13)	(312)	(312)	(312)
			6075	5700	4700	5100	6075	6075	6075
Time constants (sec)			<u>600</u>	<u>380</u>	<u>400</u>	<u>416</u>	<u>416</u>	<u>440</u>	<u>480</u>
			(07)	(13)	(13)	(13)	(312)	(312)	(312)
Transient			0.167	0.164	0.164	0.164	0.155	0.155	0.155
Subtransient			0.018	0.019	0.019	0.019	0.0177	0.0177	0.0177
Open circuit			4.17	3.93	3.93	3.93	4.05	4.05	4.05
DC			0.031	0.026	0.026	0.026	0.036	0.036	0.036
Windings (@22° C)			<u>600</u>	<u>380</u>	<u>400</u>	<u>416</u>	<u>416</u>	<u>440</u>	<u>480</u>
			(07)	(13)	(13)	(13)	(312)	(312)	(312)
Stator resistance	(L-L Ohms)		0.0032	0.0014	0.0014	0.0014	0.0024	0.0024	0.0024
Rotor resistance	(Ohms)		1.710	1.710	1.710	1.710	1.710	1.710	1.710
Number of leads			6	6	6	6	6	6	6



Alternator Data Sheet Frame Size: S7L1D-C4

S7L1D-C4 Wdg.312

THREE PHASE EFFICIENCY CURVES

50Hz

60Hz

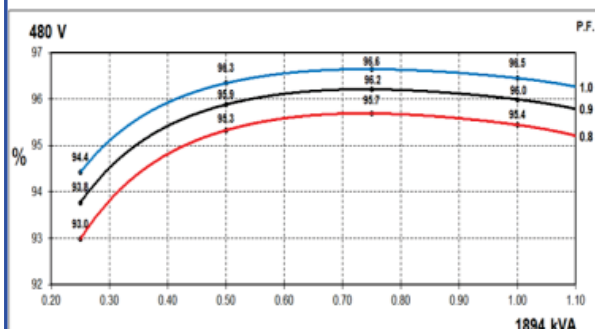
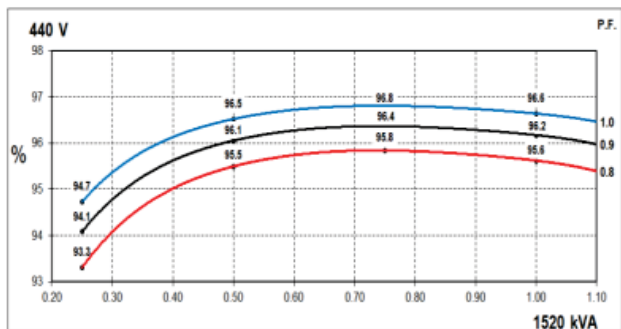
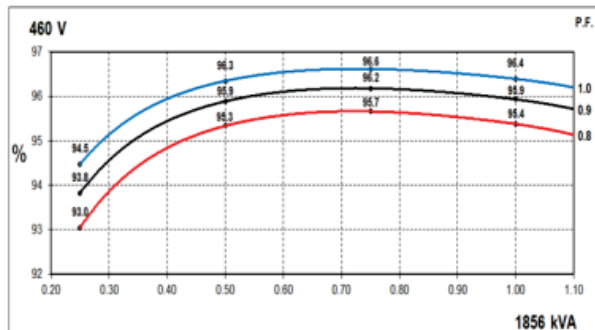
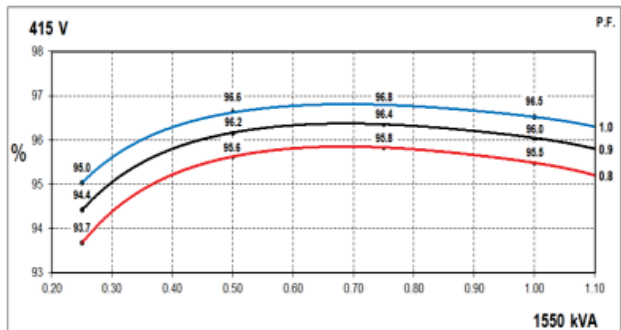
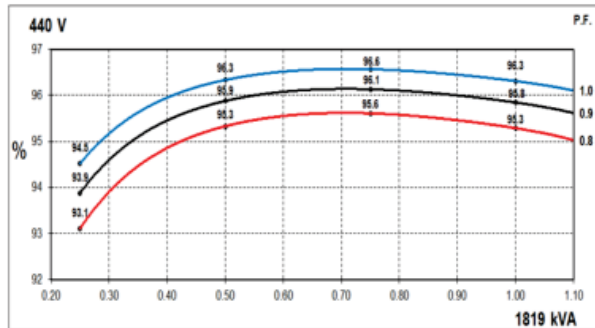
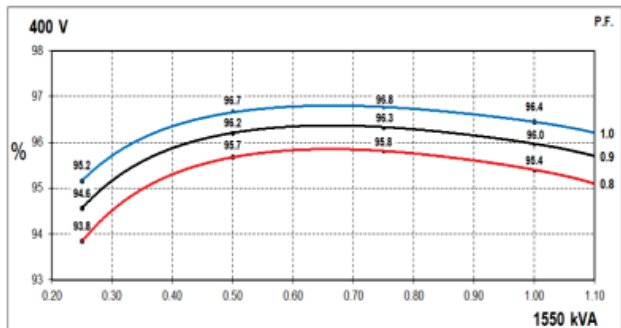
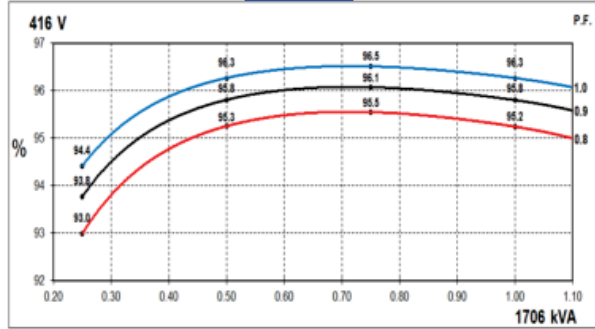
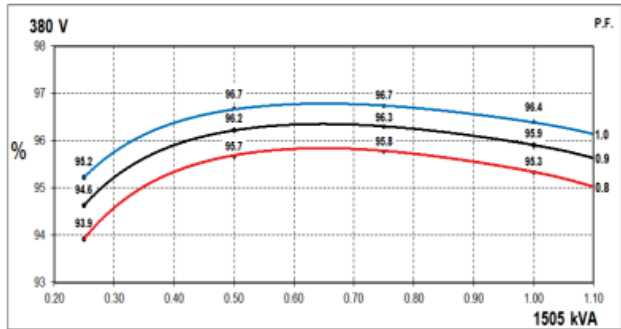



Alternator Data Sheet

Frame Size: S7L1D-C4

S7L1D-C4 Wdg.312

Locked Rotor Motor Starting Curves - Separately Excited

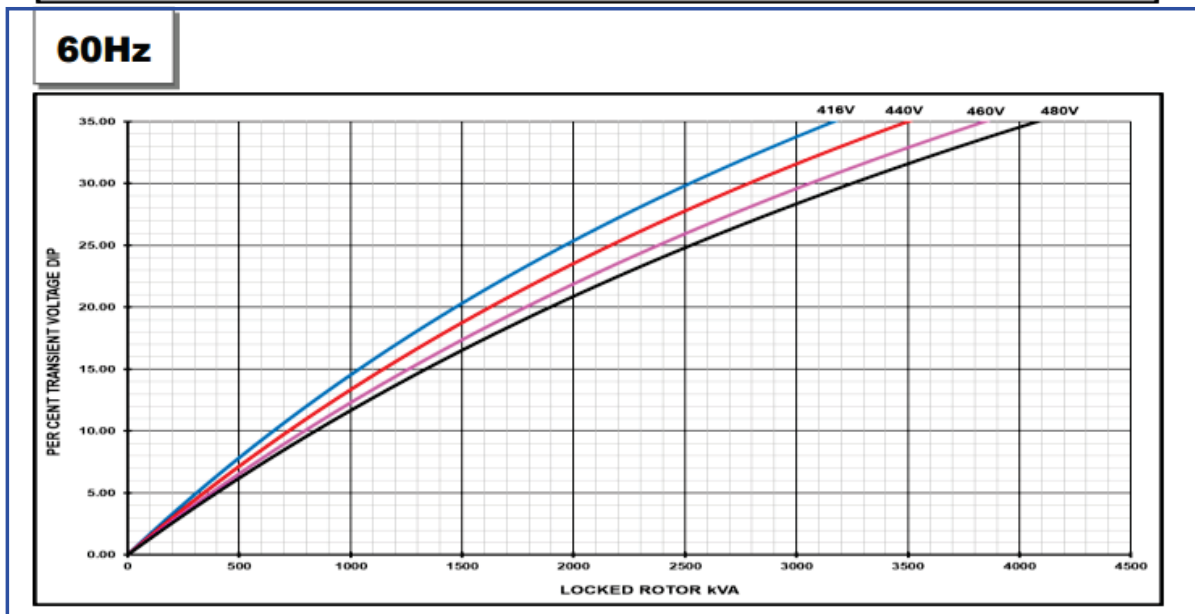
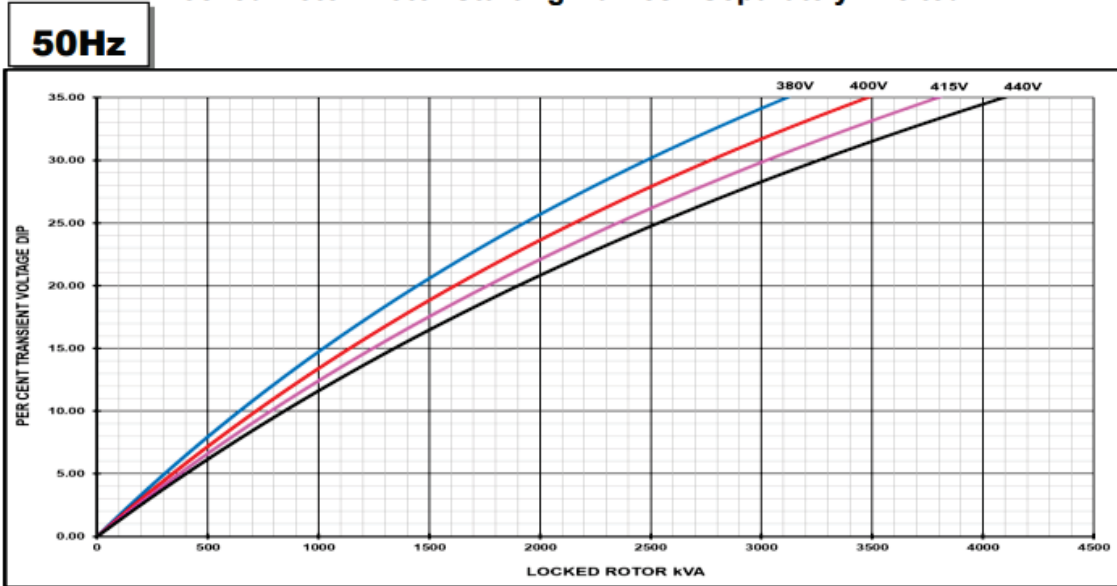

Transient Voltage Dip Scaling Factor		Transient Voltage Rise Scaling Factor
PF	Factor	For voltage rise multiply voltage dip by 1.25
< 0.5	1	
0.5	0.97	
0.6	0.93	
0.7	0.9	
0.8	0.85	
0.9	0.83	



Alternator Data Sheet

Frame Size: S7L1D-C4

S7L1D-C4 Wdg.312

Three-phase Short Circuit Decrement Curve - Separately Excited

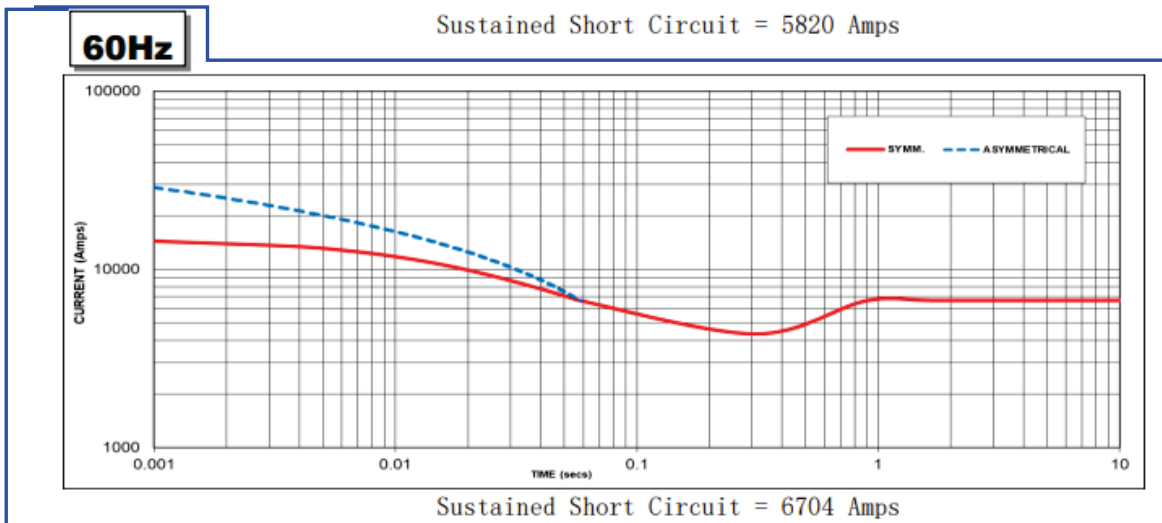
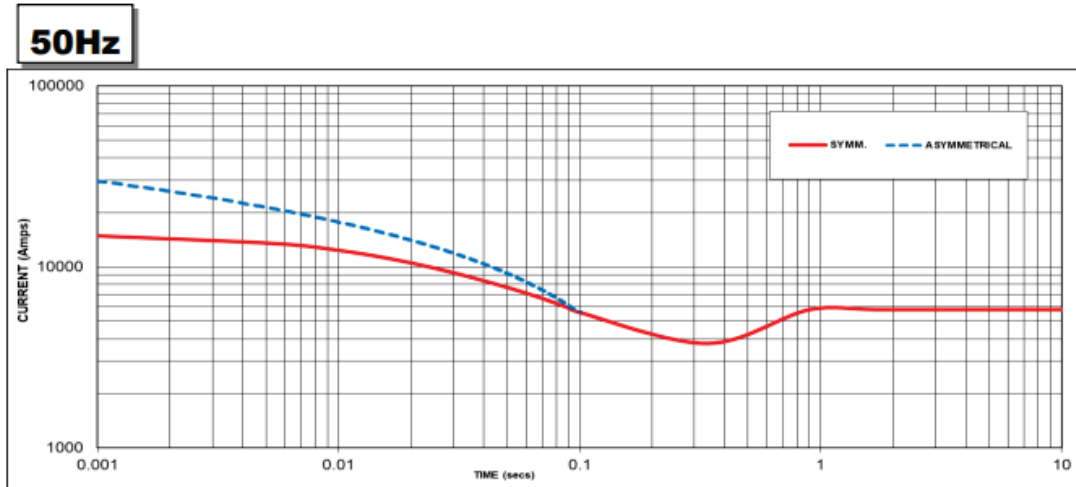

Note 1

The following multiplication factors should be used to adjust the values from curve between time 0.001 seconds and the minimum current point in respect of nominal operating voltage :

50Hz		60Hz	
Voltage	Factor	Voltage	Factor
380V	X 1.00	416V	X 1.00
400V	X 1.05	440V	X 1.06
415V	X 1.09	460V	X 1.10
440V	X 1.16	480V	X 1.15

The sustained current value is constant irrespective of voltage level

Note 2

The sustained current values are for MX341 AVR. For MX322 and Digital AVR 1.2 factor to be applied to the sustained short circuit

Note 3

The following multiplication factor should be used to convert the values calculated in accordance with NOTE 1 to those applicable to the various types of short circuit :

	3-phase	2-phase L-L	1-phase L-N
Instantaneous	x 1.00	x 0.87	x 1.30
Minimum	x 1.00	x 1.80	x 3.20
Sustained	x 1.00	x 1.50	x 2.50
Max. sustained duration	10 sec.	5 sec.	2 sec.

All other times are unchanged

Note 4

Curves are drawn for Star connected machines under no-load excitation at rated speeds. For other connection (where applicable) the following multipliers should be applied to current values as shown :
 Parallel Star = Curve current value X 2
 Series Delta = Curve current value X 1.732

THERMAL DAMAGE CURVE

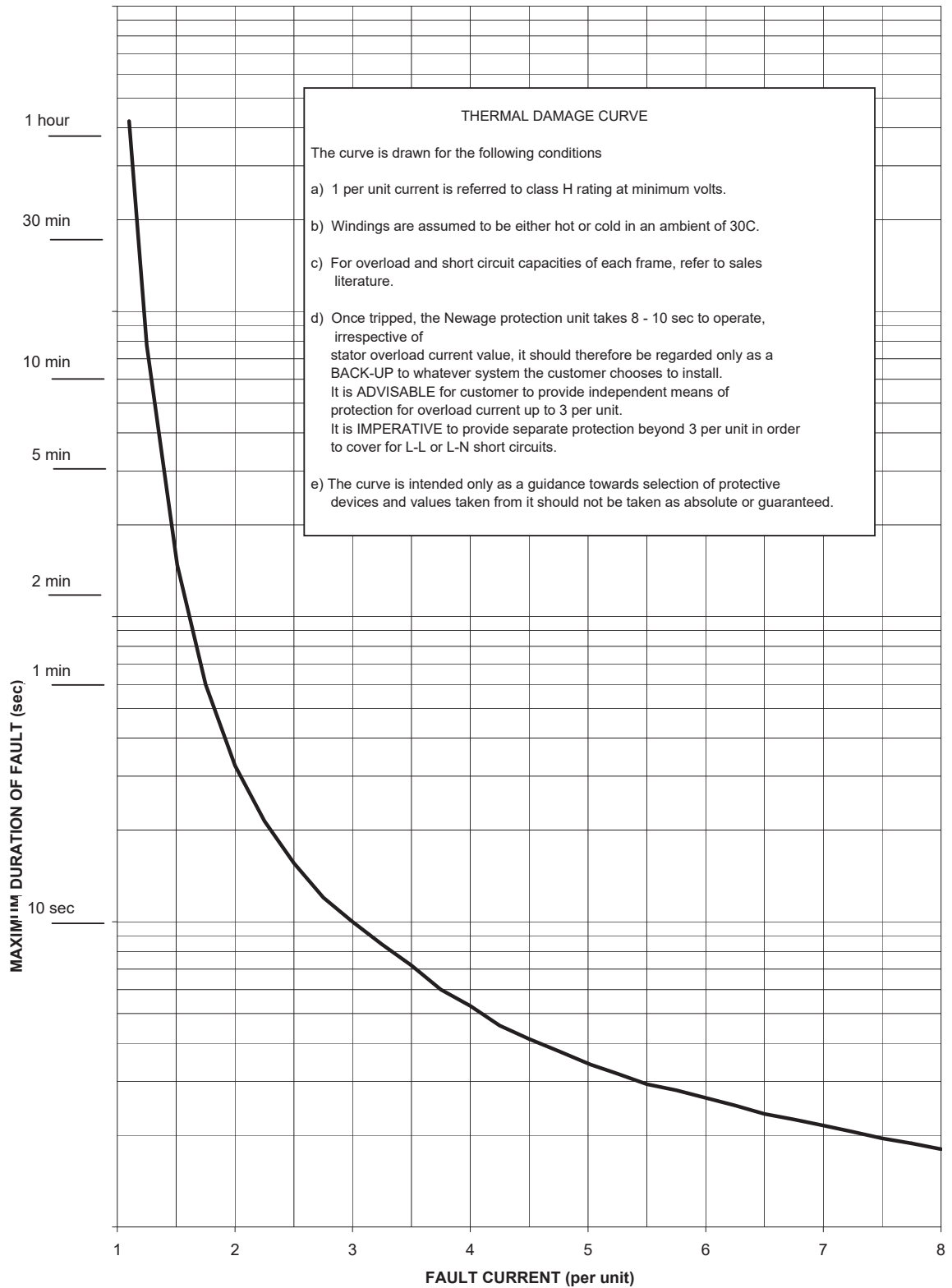

SECTION 3

GENERATOR ACCESSORIES

A solid red vertical bar is positioned on the right side of the page, extending from the top of the text area down to the bottom edge.



BATTERY CHARGER

Component specification sheet for 1000 - 1300 kW Natural gas generator sets (GenSets)

THE SMART CHOICE FOR MISSION-CRITICAL ENGINE STARTING.

Failure to start due to battery problems is the leading cause of inoperable GenSets. To achieve constant, optimal battery charge, this Cummins battery charger automatically adjusts the charge profile based on current conditions: battery depth of discharge, DC loads, battery capacity, and other real-world variables. In contrast, most competitors use simple boost timers to keep the charger output at an elevated voltage for a fixed period that is inevitably either too short or too long to achieve a correct charge. The Cummins battery charger for this GenSets offers:

- **Patented charging algorithms** – ability to recognize and automatically recharge a dead battery
- **Hardened switch mode power train** - designed to withstand vibration, electrical transients, and general exposure, delivers first-class abuse resistance and energy efficiency
- **Four-rate, temperature-compensated output** – ensures the longest battery life
- **Industry-first NFPA 110 battery-fault alarm** – troubleshoots five possible battery failures to assist dispatching a Cummins technician quickly
- **Lasting reliability** – guarantees greater than 1.2 million hours of field mean time between failures (MTBF) with the industry’s best warranty
- **UL Listed, CE marked** - Optional OSHPD pre-approval – already approved for California hospital projects



Patented smart technology built into every charger includes:

- Digital metering
- All-electronic operation with generous component de-rating
- A disconnected/reversed/incorrect voltage battery alarm and protection

Critical component	Reference drawing
A066U082	GE100177

Specifications

AC input

Voltage	170-265 VAC, single phase
Frequency	47-63 Hz
Current	12 amps maximum
Protection	1-pole fuse, soft-start, transient suppression

Charger output

Nominal voltage	24VDC
Battery settings	Charging modes - multistage, including float, boost and commissioning Compatible battery types - Flooded lead-acid, AGM, Ni-Cd, VRLA and ultracapacitor
Equalize-voltage	24-28.6VDC, dependent on configuration and battery type
Output voltage regulation	±0.5% (1/2%) line and load regulation
Maximum output current	30A
Electronic current limit	100% rated output, field adjustable
Charge characteristic	Constant voltage, current limited; Dynamic Boost control
Temperature compensation	Enable or disable anytime, remote sensor optional
Output protection	1-pole fuse, current limit

User interface

Digital meter	20-character display of status and alarm messages DC voltmeter DC ammeter
Accuracy	±2% volts, ±5% amps
Alarms	24 alarms (5 hardwired outputs, J1939 or Modbus TCP/IP) 2 LEDs (AC and DC status)

Environmental

Operating temperature	- 40 °F to +158 °F (-40 °C to +70 °C) - meets full specification to +113 °F (45 °C)
Humidity	5% to 95%, non-condensing
Vibration	Vib: Swept Sine (EN60068-2-6): 4G, 18-500 Hz, 3 axes. Random: 20-500Hz, .01G2/Hz. Shock: EN 60068-2-27 (15G)
Transient immunity	ANSI/IEEE C62.41 & EN 61000-4-12 on power terminals

Applicable codes and standards

ISO 9001:2015

This product has been manufactured under the controls established by an approved management system that conforms with ISO 9001:2015.



Cummins Inc.
Box 3005
Columbus, IN 47202-3005
U.S.A.

1-800-CUMMINS™ (1-800-286-6467)
cummins.com

Printed in U.S.A.
©2023 Cummins Inc.

CUMMINS PREMIUM[®]

C8DXH-FT

KEEP YOUR DAY POWERED WITH QUALITY AND DURABILITY.

Cummins offers batteries of outstanding performance and battery warranties for any transport which needs to resist high or low temperatures.

- 12-volt, heavy-duty commercial battery.
- Reliable battery for any weather.
- 18-month free replacement.
- Anchor bonded for vibration resistance.
- Sealed and reinforced polypropylene case.
- Maintenance free plate materials.



SPECIFICATIONS

Group Size	8D
Terminal BCI Figure	SAE
Voltage	12
CCA 0°F (-18°C) (SAE-Standard)	1400
CA 32°F (0°C) (SAE-Standard)	1750
RC @80°F (27°C) (SAE-Standard)	450
Ampere Hour	188
Weight (lb)	132.3
Electrolyte Quantity Gallons	4.25
Electrolyte Quantity Fluid Ounces	544

BATTERY DIMENSIONS

Terminal BCI Figure



SAE

Length: **20 3/4"**

Width: **11 1/8"**

Height: **9 7/8"**

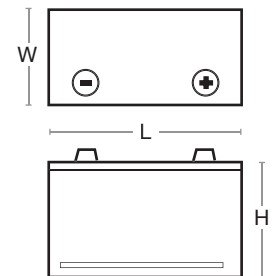

*This battery is only available for purchase in the US

TYPE OF ELECTROLYTE

- Sulfuric Acid
- Water
- Solution

SDS #UN2794

For more information contact us: 1-800-CUMMINS™

©2019 Cummins Inc., Box 3005, Columbus, IN 47202-3005 Bulletin 5600255 Printed in U.S.A. 9/19



Product data sheet

Specifications

SQUARE D

Green Premium[®]



Circuit breaker, PowerPacT R,
2000A, 3 pole, 600VAC, 50kA,
busbar, Micrologic 5.0

RLF36200U33F

Main

Range	PowerPact
Product Name	PowerPact R
Product Or Component Type	Circuit breaker
Device Application	Distribution

Complementary

Line Rated Current	2000 A
Number Of Poles	3P
Control Type	Operating handle
Breaking Capacity Code	L
Breaking Capacity	AIR 125 kA 240 V AC 50/60 Hz UL 489 AIR 100 kA 480 V AC 50/60 Hz UL 489 AIR 50 kA 600 V AC 50/60 Hz UL 489 Icu 125 kA 240 V AC 50/60 Hz IEC 60947-2 Icu 85 kA 380/415 V AC 50/60 Hz IEC 60947-2
[Ue] Rated Operational Voltage	600 V AC 50/60 Hz UL 489
Network Frequency	50/60 Hz
[Ics] Rated Service Breaking Capacity	65 kA 240 V AC 50/60 Hz IEC 60947-2 45 kA 380/415 V AC 50/60 Hz IEC 60947-2
[Uimp] Rated Impulse Withstand Voltage	8 kV IEC 60947-2
Trip Unit Technology	Electronic, standard, MicroLogic 5.0, LSI
[Ui] Rated Insulation Voltage	750 V IEC 60947-2
Trip Unit Name	MicroLogic 5.0
Suitability For Isolation	Yes IEC 60947-2
Utilisation Category	Category A
Awg Gauge	Please see CB outline drawing for lug and termination details
Local Signalling	Alarm 1 LED (yellow) (long-time pick up)
Mounting Mode	Unit mount (busbar)
Mounting Support	Busbar
Electrical Connection	Busbar connection, line Busbar connection, load

Disclaimer: This documentation is not intended as a substitute for and is not to be used for determining suitability or reliability of these products for specific user applications

Terminal Identifier	Please see CB outline drawing for lug and termination details
Tightening Torque	601.85 lbf.in (68 N.m) 0.08...0.62 in ² (50...400 mm ²) (AWG 1/0...750 kcmil) 601.85 lbf.in (68 N.m) 0.08...0.23 in ² (50...150 mm ²) (2 x AWG 1/0...2 x 300 kcmil)
Number Of Slots	2 auxiliary switch OF plug-in 1 alarm switch SD plug-in 1 voltage release MN or MX plug-in)
Power Wire Stripping Length	1.38 in (35 mm)
Height	16.24 in (412.50 mm)
Width	16.54 in (420.12 mm)
Depth	14.49 in (368.05 mm)
Net Weight	52 lb(US) (23.59 kg)
Quantity Per Set	1
Circuit Breaker Application	HACR rated

Environment

Quality Labels	CE
Standards	UL CSA NEMA NMX J-266 IEC 60947-2
Product Certifications	UL CSA NOM
Ip Degree Of Protection	IP40
Pollution Degree	3 IEC 60947-1
Ambient Air Temperature For Operation	-13...158 °F (-25...70 °C)
Ambient Air Temperature For Storage	-58...185 °F (-50...85 °C)
Operating Altitude	< 6561.68 ft (2000 m) without derating 13123.36 ft (4000 m) with derating

Ordering and shipping details

Category	US10DE201245
Discount Schedule	0DE2
Gtin	
Returnability	Yes

Packing Units

Unit Type Of Package 1	PCE
Number Of Units In Package 1	1
Package 1 Height	16.22 in (41.2 cm)
Package 1 Width	16.54 in (42.0 cm)
Package 1 Length	14.49 in (36.8 cm)
Package 1 Weight	74.00 lb(US) (33.566 kg)

Sustainability

Green Premium™ label is Schneider Electric's commitment to delivering products with best-in-class environmental performance. Green Premium promises compliance with the latest regulations, transparency on environmental impacts, as well as circular and low-CO₂ products.

Guide to assessing product sustainability is a white paper that clarifies global eco-label standards and how to interpret environmental declarations.

[Learn more about Green Premium >](#)

[Guide to assess a product's sustainability >](#)



Transparency RoHS/REACH

Well-being performance

✓ Mercury Free

✓ Rohs Exemption Information [Yes](#)

✓ Pvc Free

✓ Halogen Free Plastic Parts Product

Certifications & Standards

Reach Regulation

[REACH Declaration](#)

Eu Rohs Directive

Compliant with Exemptions

China Rohs Regulation

[China RoHS declaration](#)

Product out of China RoHS scope. Substance declaration for your information.

Environmental Disclosure

[Product Environmental Profile](#)

Circularity Profile

[End of Life Information](#)

California Proposition 65

WARNING: This product can expose you to chemicals including: DINP, which is known to the State of California to cause cancer, and DIDP, which is known to the State of California to cause birth defects or other reproductive harm. For more information go to www.P65Warnings.ca.gov

Micrologic™ 5.0 Electronic Trip Unit

Instruction Bulletin

48049-207-05

Rev. 01, 07/2012

Retain for future use.



Micrologic 5.0 Trip Unit

The Micrologic 5.0 trip unit provides selective (LSI) protection.

- A. Long-time pickup (I_r) switch
- B. Long-time delay (t_r) switch
- C. Short-time pickup (I_{sd}) switch
- D. Short-time delay (t_{sd}) switch
- E. Instantaneous pickup (I_i) switch
- F. Test plug receptacle
- G. Overload indicator light
- H. Trip unit name

Figure 4: Micrologic 5.0 Trip Unit

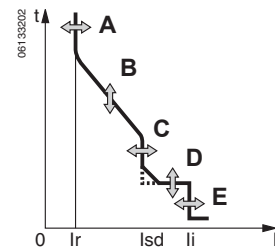
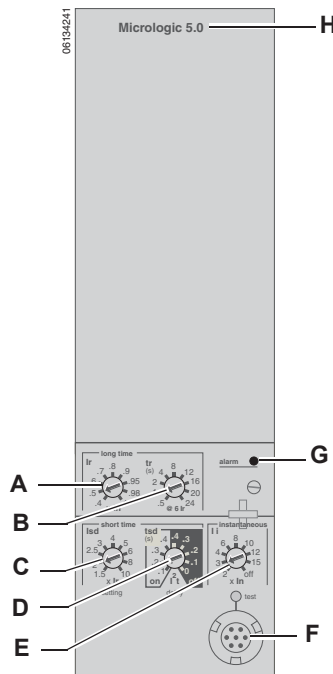

Trip Unit Switches

Long-Time Protection

Long-time protection protects equipment against overloads.

- Long-time protection is standard on all trip units.
- The long-time pickup (Ir) (A) sets maximum current level (based on sensor plug rating In) which circuit breaker will carry continuously. If current exceeds this value, circuit breaker will trip after the preset time delay. The long-time pickup (Ir) is adjustable from 0.4–1.0 times the sensor plug rating (In).
- The long-time delay (tr) (B) sets the length of time that the circuit breaker will carry an overcurrent below the short-time or instantaneous pickup current level before tripping. See Table 1 for long-time delay settings.
- The overload indicator light (C) indicates that the Ir long-time pickup threshold has been exceeded.
- Both long-time pickup and long-time delay are on the field-replaceable adjustable rating plug. To change settings to more precisely match the application, various rating plugs are available. For instructions on replacing the rating plug, see Section 4—Adjustable Rating Plug Replacement.
- The In value can be changed by replacing the sensor plug below the trip unit. For further information, see the instructions packed with the sensor plug replacement kit.
- Long-time protection uses true RMS measurement.

Thermal imaging provides continuous temperature rise status of the wiring, both before and after the device trips. This allows the circuit breaker to respond to a series of overload conditions which could cause conductor overheating, but would go undetected if the long-time circuit was cleared every time the load dropped below the pickup setting or after every tripping event.

NOTE: If checking trip times, wait a minimum of 15 minutes after circuit breaker trips before resetting to allow the thermal imaging to reset completely to zero.

Figure 5: Long-Time Protection Switches

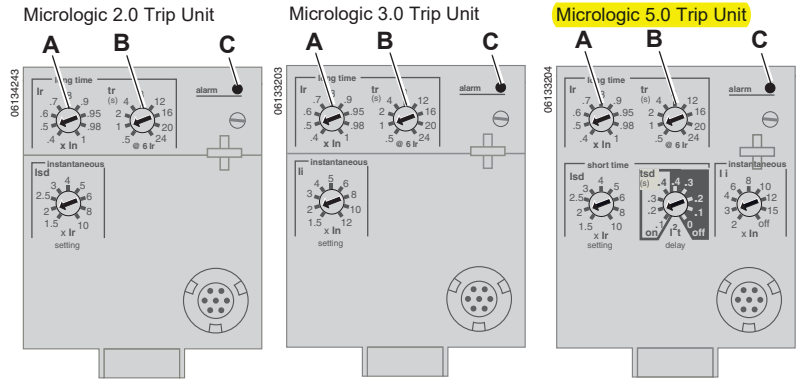

Table 1: Micrologic Trip Unit Long-Time Delay Values

Setting ¹	Long-Time Delay in Seconds ²								
tr at 1.5 x Ir	12.5	25	50	100	200	300	400	500	600
tr at 6 x Ir	0.5	1	2	4	8	12	16	20	24
tr at 7.2 x Ir	0.34 ³	0.69	1.38	2.7	5.5	8.3	11	13.8	16.6

¹In = sensor rating. Ir = In x long-time pickup. Trip threshold between 1.05 and 1.20 Ir.

²Time-delay accuracy +0/-20%

³For Micrologic 5.0 trip units, when tsd is set to 0.4 off or 0.4 on, then tr = 0.5 instead of 0.34.

Short-Time Protection

Short-time protection protects equipment against short circuits.

- Short-time protection is standard on 2.0 and 5.0 trip units. It is not available on 3.0 trip units.
- Short-time protection is based on the long-time pickup (I_r)
- The short-time pickup (I_{sd}) (A) sets the current level (below instantaneous trip level) where the circuit breaker will trip after the preset time delay.
- The short-time delay (t_{sd}) (B) sets the length of time that the circuit breaker will carry an overcurrent above the short-time pickup current level before tripping. It is adjustable on the 5.0 trip unit and factory set to zero on the 2.0 trip unit.
- The I^2t on/ I^2t off option provides improved selectivity with downstream protective devices:
- With I^2t off selected, fixed time delay is provided.
 - With I^2t on selected, inverse time I^2t protection is provided up to $10 \times I_r$. Above $10 \times I_r$, a fixed time delay is provided.
 - Intermittent currents in the short-time tripping range which do not last sufficiently long to trigger a trip are accumulated and shorten the trip delay appropriately.
- Setting t_{sd} to the 0 setting turns off time-delay features.
- Short-time protection uses true RMS measurement.
- Short-time delay can be adjusted to provide selectivity with a downstream circuit breaker.

Figure 6: Short-Time Protection Switches

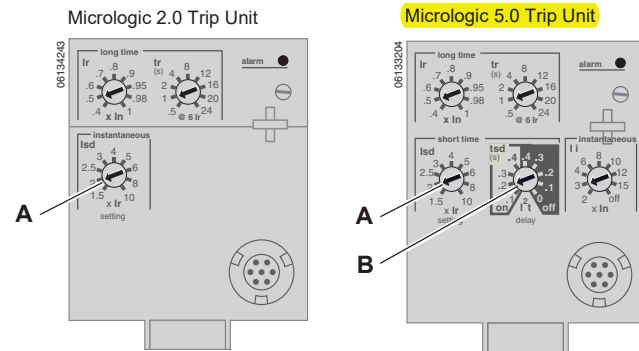

Table 2: Micrologic Trip Unit Short-Time Delay Values

Setting	Short-Time Delay				
	0	0.1	0.2	0.3	0.4
I^2t off (I_{sd} at 10 I_r) (seconds)	0	0.1	0.2	0.3	0.4
I^2t on (I_{sd} at 10 I_r) (seconds)	—	0.1	0.2	0.3	0.4
t_{sd} (min. trip) (milliseconds)	20	80	140	230	350
t_{sd} (max. trip) (milliseconds)	80	140	200	320	500

Instantaneous Protection

Instantaneous protection protects equipment against short circuits with no intentional time delay.

- Instantaneous protection (li) (A) is standard on 3.0 and 5.0 trip units.*
- Instantaneous protection for 2.0 trip units is based on the circuit breaker sensor rating (Ir).
- Instantaneous protection for 3.0 and 5.0 trip units is based on the long-time delay pickup (In).
- Circuit breaker open command is issued as soon as threshold current is exceeded.
- Instantaneous protection for 3.0 and 5.0 trip units use peak current measurement. Instantaneous protection for 2.0 trip units use RMS current measurement.
- When instantaneous protection switch is set to off, the instantaneous protection is disabled.

*Instantaneous protection on 2.0 trip units is achieved by using short-time protection (Isd) with short-time delay factory set to 0 (zero).

Figure 7: Instantaneous Protection Switches

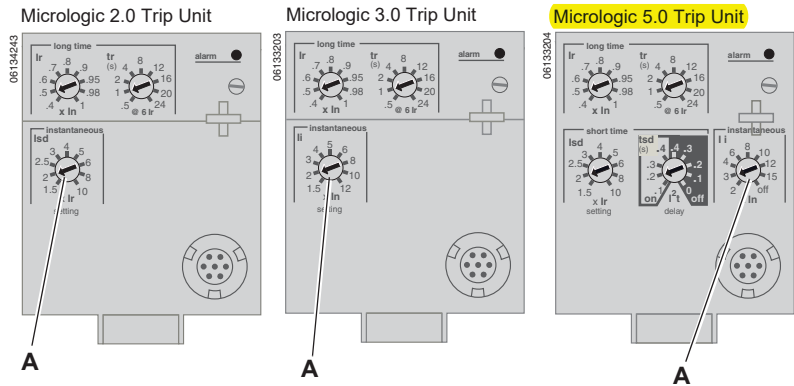

Table 3: Micrologic Instantaneous Values

Setting	Interruption Current								
2.0 Isd (= Ir x..)	1.5	2	2.5	3	4	5	6	8	10
3.0 li (= In x..)	1.5	2	3	4	5	6	8	10	12
5.0 li (= In x..)	2	3	4	6	8	10	12	15	off

li = UL and ANSI instantaneous
Isd = IEC instantaneous (short-time with zero delay)
In = sensor rating
Ir = long-time pickup

Overload Indicator Light

The overload indicator light (A) lights when the Ir long-time pickup level has been exceeded.

Figure 8: Overload Indicator Lights

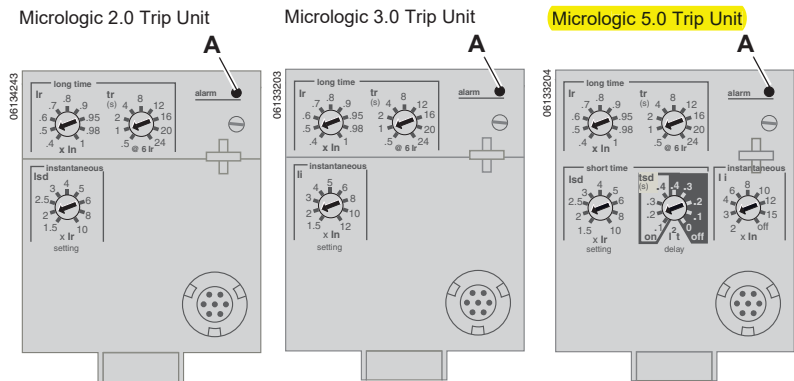

Trip Unit Testing

Trip unit functions can be tested using primary injection testing or secondary injection testing.

Section 2—Operation

Switch Adjustment

1. Open switch cover (A).
2. Adjust the appropriate switches (B) to desired values.
3. Replace switch cover. Use wire seal MICROTUSEAL (C), if necessary, to provide tamper evidence.

Figure 9: Adjust Switch Settings

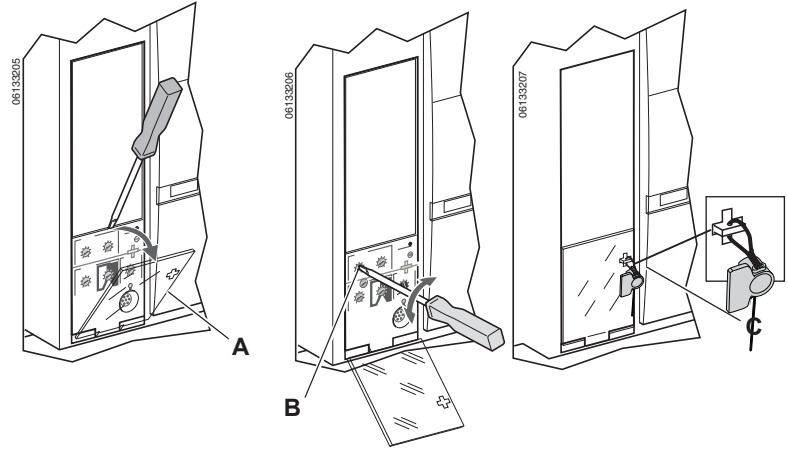

Examples

Circuit breaker is rated 2000 A.

Figure 10: Circuit Breaker Rating

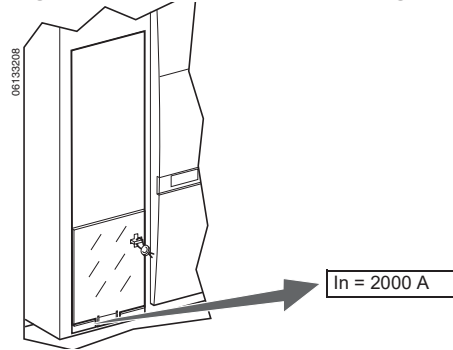

Micrologic 5.0 Trip Unit

1. Set pickup levels.

Figure 15: Set Pickup Levels

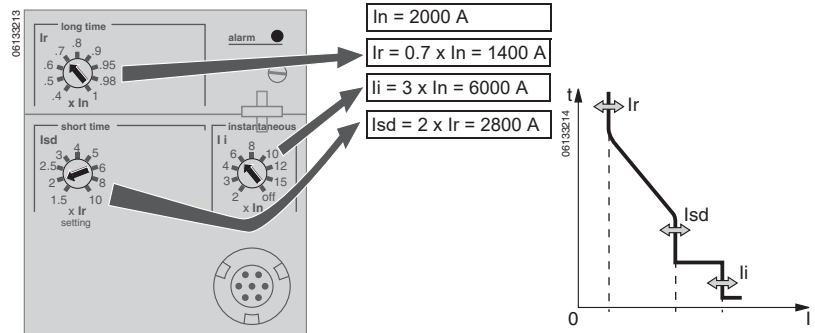

2. Set time delay.

Figure 16: Set Time Delay

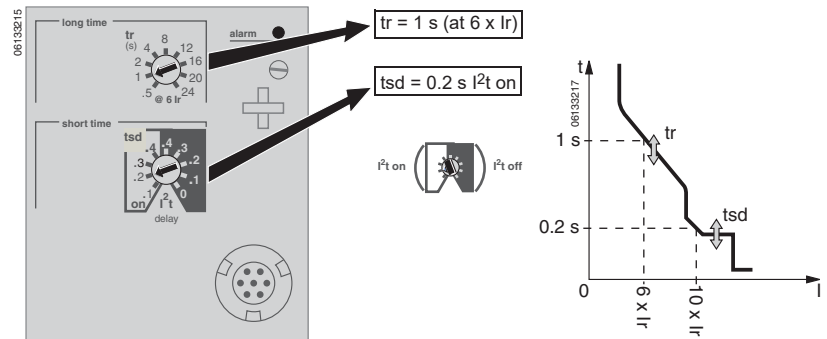

Trip Unit Operation Verification

Use a test kit connected to the trip unit test plug receptacle (A) to verify trip unit is functioning as desired. See instructions shipped with test kit to perform verification tests.

Figure 17: Verify Trip Unit Operation

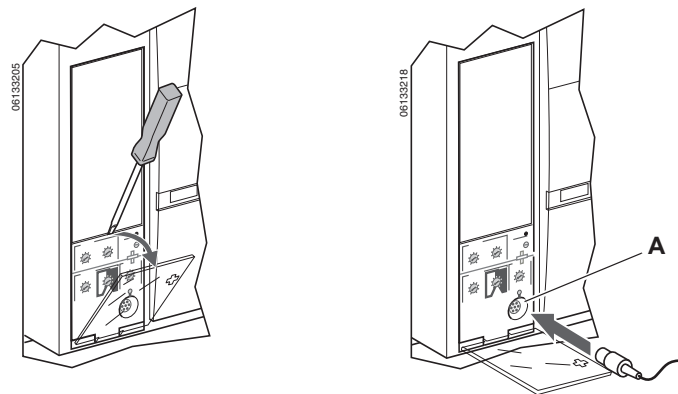

CURRENT IN MULTIPLES OF I_r (I_r = LONG-TIME SETTING x I_n)

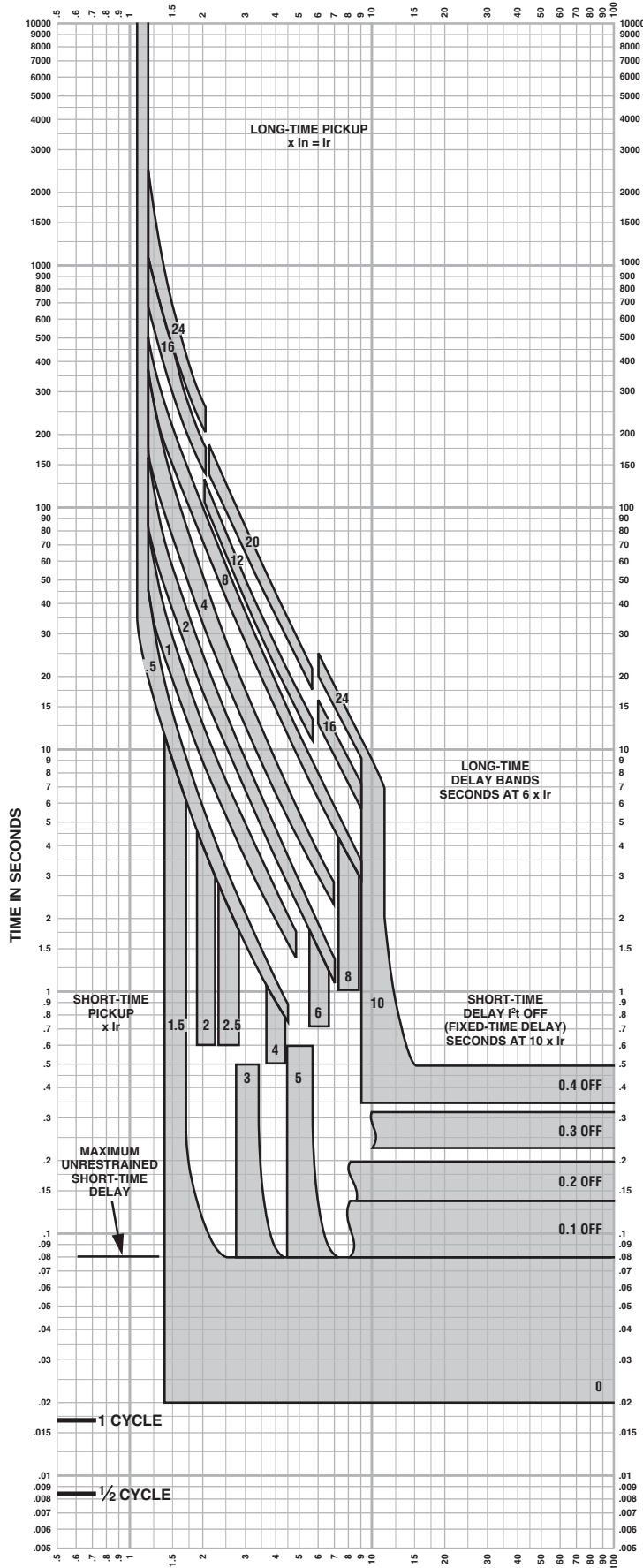

**MICROLOGIC® 5.0/6.0 A/P/H TRIP UNIT
CHARACTERISTIC TRIP CURVE NO. 613-4**

Long-time Pickup and Delay
Short-time Pickup and I²t OFF Delay

The time-current curve information is to be used for application and coordination purposes only.

Curves apply from -30°C to +60°C ambient temperature.

Notes:

1. There is a thermal-imaging effect that can act to shorten the long-time delay. The thermal-imaging effect comes into play if a current above the long-time delay pickup value exists for a time and then is cleared by the tripping of a downstream device or the circuit breaker itself. A subsequent overload will cause the circuit breaker to trip in a shorter time than normal. The amount of time delay reduction is inverse to the amount of time that has elapsed since the previous overload. Approximately 20 minutes is required between overloads to completely reset thermal-imaging.
2. The end of the curve is determined by the interrupting rating of the circuit breaker.
3. With zone-selective interlocking on, short-time delay utilized and no restraining signal, the maximum unrestrained short-time delay time band applies regardless of the setting.
4. Total clearing times shown include the response times of the trip unit, the circuit breaker opening, and the extinction of the current.
5. For a withstand circuit breaker, instantaneous can be turned OFF. See 613-7 for instantaneous trip curve. See 613-10 for instantaneous override values.
6. Overload indicator illuminates at 100%.

- Merlin Gerin
 - Modicon
 - Square D
 - Telemecanique
 - Federal Pioneer
 - Federal Pacific
- Schneider Electric Brands

CURRENT IN MULTIPLES OF I_r
(I_r = LONG-TIME SETTING x I_n)



© 2000 Schneider Electric. all rights reserved.

CURRENT IN MULTIPLES OF Ir (Ir = LONG-TIME SETTING x In)

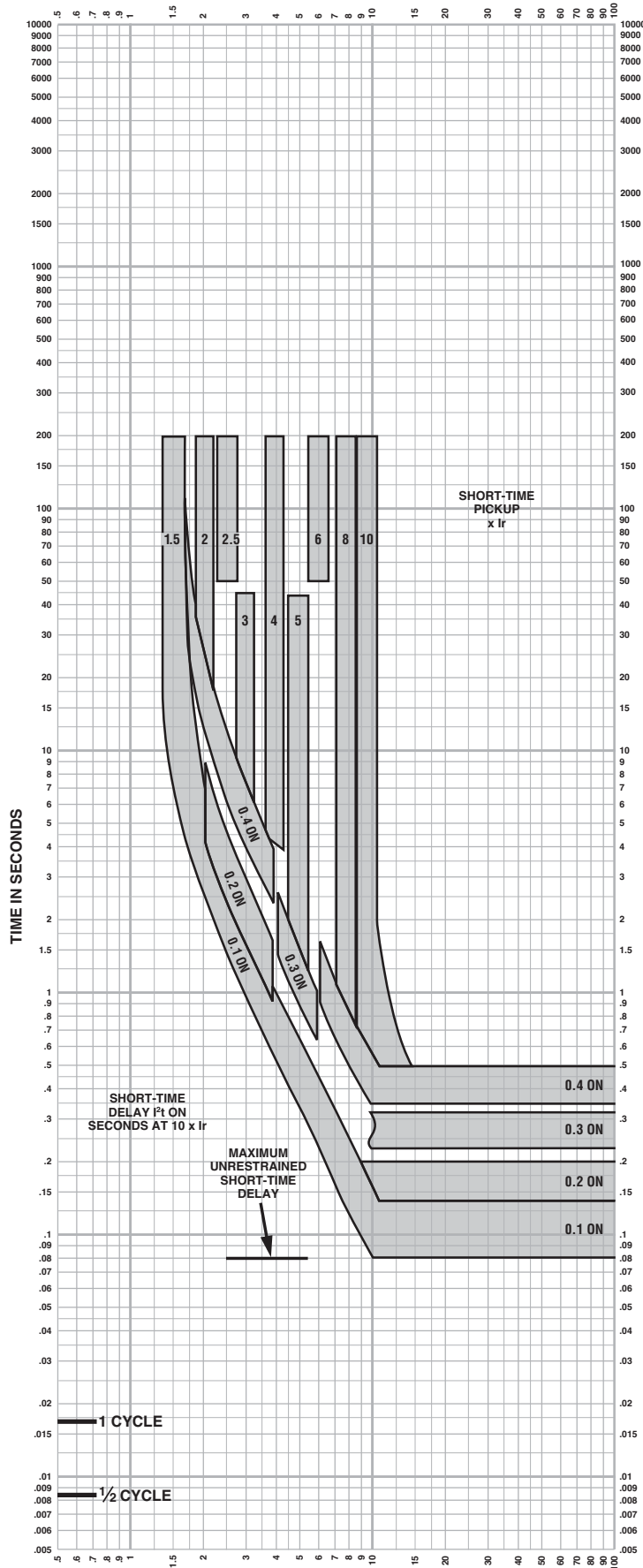

**MICROLOGIC® 5.0/6.0 A/P/H TRIP UNIT
CHARACTERISTIC TRIP CURVE NO. 613-5**

Short-time Pickup and I²t ON Delay

The time-current curve information is to be used for application and coordination purposes only.

Curves apply from -30°C to +60°C ambient temperature.

Notes:

1. There is a thermal-imaging effect that can act to shorten the long-time delay. The thermal-imaging effect comes into play if a current above the long-time delay pickup value exists for a time and then is cleared by the tripping of a downstream device or the circuit breaker itself. A subsequent overload will cause the circuit breaker to trip in a shorter time than normal. The amount of time delay reduction is inverse to the amount of time that has elapsed since the previous overload. Approximately 20 minutes is required between overloads to completely reset thermal-imaging.
2. The end of the curve is determined by the interrupting rating of the circuit breaker.
3. With zone-selective interlocking on, short-time delay utilized and no restraining signal, the maximum unrestrained short-time delay time band applies regardless of the setting.
4. Total clearing times shown include the response times of the trip unit, the circuit breaker opening, and the extinction of the current.
5. For a withstand circuit breaker, instantaneous can be turned OFF. See 613-7 for instantaneous trip curve. See 613-10 for instantaneous override values.
6. See 613-4 for long-time pickup and delay trip curve.

- Merlin Gerin
 - Modicon
 - Square D
 - Telemecanique
 - Federal Pioneer
 - Federal Pacific
- Schneider Electric Brands

CURRENT IN MULTIPLES OF Ir
(Ir = LONG-TIME SETTING x In)

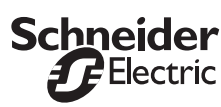

© 2000 Schneider Electric. all rights reserved

Curve No. 0613TC0005
December 2000
Drawing No. B48095-613-05

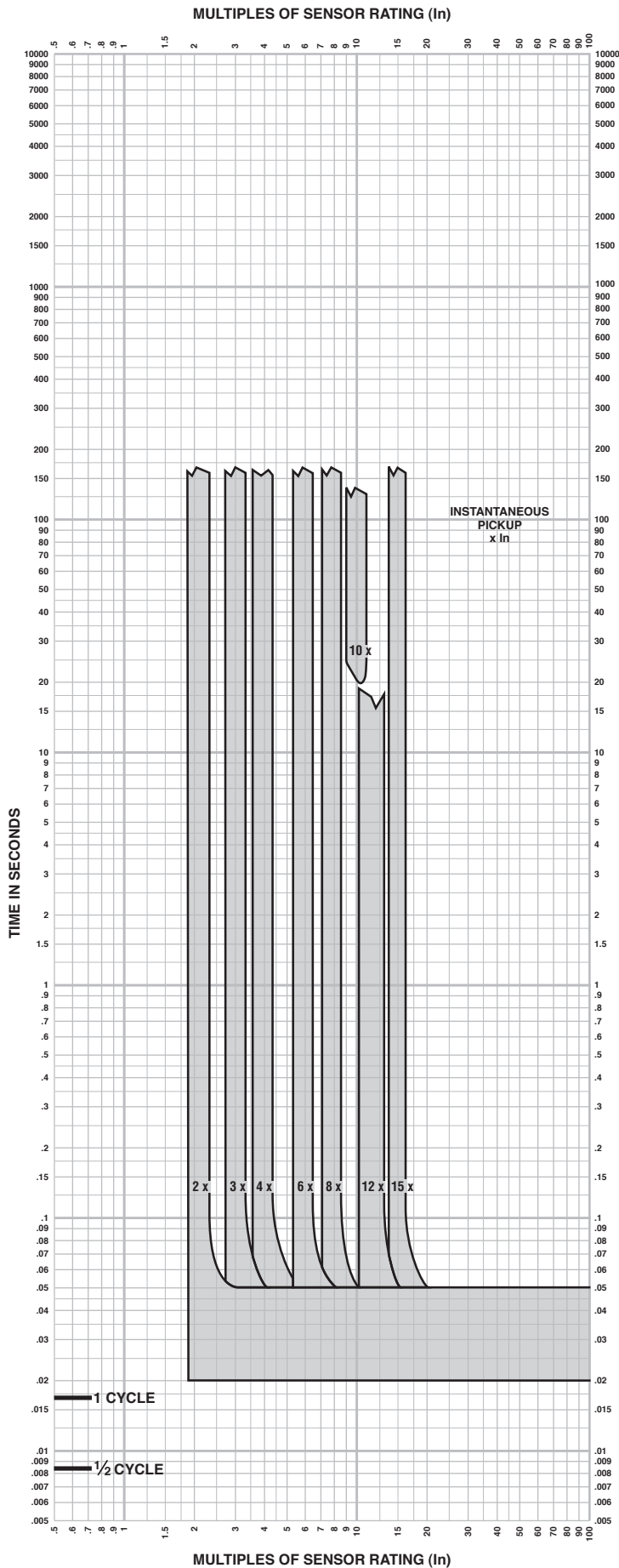

**MICROLOGIC® 5.0/6.0 A/P/H TRIP UNIT
CHARACTERISTIC TRIP CURVE NO. 613-7**

Instantaneous Pickup
2x-15x and OFF

The time-current curve information is to be used for application and coordination purposes only.

Curves apply from -30° to +60°C ambient temperature.

Notes:

1. The end of the curve is determined by the interrupting rating of the circuit breaker.
2. Total clearing times shown include the response times of the trip unit, the circuit breaker opening, and the extinction of the current.
3. The instantaneous region of the trip curve shows maximum total clearing times. Actual clearing times in this region can vary depending on the circuit breaker mechanism design and other factors. The actual clearing time can be considerably faster than indicated. Contact your local Sales Office for additional information.
4. For a withstand circuit breaker, instantaneous can be turned OFF. See 613-7 for instantaneous trip curve. See 613-10 for instantaneous override values.
5. See 613-4 and 613-5 for long-time pickup, long-time delay, short-time pickup, and short-time delay trip curves.

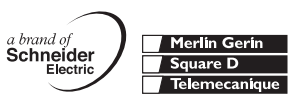



PowerCommand[®] annunciator discrete input or PCCNet



Description

The Universal Annunciator Module provides visual and audible indication of up to 20 separate alarm or status conditions, based on discrete (relay) inputs or network inputs. Each LED can be controlled by either a discrete wire input or by a signal on the PCCNet network sent from an external device, such as a PCC1301 or PCC2100 (version 2.4 or later) control.

In addition to the LEDs, the annunciator can control four custom relays based on signals received over the PCCNet. When one of the annunciator's discrete inputs is activated, the annunciator will broadcast that information over the network. By taking advantage of the network, discrete inputs and custom relays, the annunciator can be used as expanded I/O for a genset controller.

Easily installed in a location to give immediate notification of an alarm or warning status. Designed to give operating/monitoring personnel quick-glance status information. The module directly senses battery voltage to provide green/yellow/red alarm and status information for that parameter.

Genset controller complies with NFPA level two requirements when used with the display but without the annunciator panel. When used with the annunciator it meets NFPA level one requirements (Emergency and Standby power systems). The annunciator module can also be used for monitoring of transfer switch or other equipment status.

Features

- Visual and audible warnings of up to 20 separate alarm or status conditions.
- LEDs can be controlled either via PCCNet or discrete input.
- Status of discrete inputs is broadcast on network.
- Four custom relays can be controlled over the PCCNet network.
- Configurable LED color (red, yellow or green) and selectable horn operation allows maximum flexibility.
- Standard NFPA 110 label, field configurable for other alarm status and conditions.
- Each audible alarm is annunciated, regardless of the number of existing alarm conditions displayed.
- Sealed membrane panel design provides environmental protection for internal components and is easy to clean.
- Configurable for negative (ground) input or positive input.
- Integral DC voltage sensing.
- Flush or surface mount provisions.
- UL Listed and labeled; CSA certified; CE marked.

Specifications

Signal requirements

Positive - Input impedance is 1.82 kOhms to ground; maximum input voltage = 31 VDC.

Negative - Input impedance is 1.82 kOhms to Bat+: inputs are at Bat+ level when open.

Sink/source current threshold for detection - 150 Ua minimum, 3 mA maximum.

Typical conductor size: 16 ga for 304.8 m (1000 ft)

Max conductor size for terminal: 12 ga

Relay outputs

0.2 A at 125 VAC and 1 A at 30 VDC

Network connections

Use Belden 9729 two pair, stranded, shielded 24 AWG twisted pair cable for all PCCNet connections. Total network length cannot exceed 1219 m (4000 ft). Up to 20 nodes can be connected to the network.

Note: Any communications wire connected to the generator set should be stranded cable.

Power

Maximum consumption: 15 watts

Battery voltage

Functional range - Audible and visual conditions operational from 6.5 to 31 VDC.

Low voltage setting - 12.0 VDC for 12 Volt nominal systems; 24.0 for 24 Volt nominal systems.

High voltage setting - 16.0 Volt for 12 Volt nominal systems; 32.0 Volt for 24 Volt nominal systems.

Alarm horn

Sound level: 90 dB at 30 cm

Physical

Weight (with enclosure): 1.4 kg (3.0 lbs)

Temperature

-20 °C to +70 °C (-4 °F to +158 °F)

Humidity

10% to 95% RH (non-condensing)

Default lamp configurations

Can be configured for current NFPA 110 standard or as a replacement for Legacy (pre-2001) NFPA 110 annunciator (300-4510 or 300 4511)

Lamp	Description	NFPA 110		
		Color	Horn	Flash
DS1	Customer fault 1	Green	No	No
DS2	Customer fault 2	Amber	No	No
DS3	Customer fault 3	Red	No	No
DS4	Genset supplying load	Amber	No	No
DS5	Charger AC failure	Amber	Yes	No
DS6	Low coolant level	Amber	Yes	No
DS7	Low fuel level	Red	Yes	No
DS8	Check generator set	Amber	No	No
DS9	Not in auto	Red	Yes	Yes
DS10	Generator set running	Amber	No	No
DS11	High battery voltage	Amber	Yes	No
DS12	Low battery voltage	Red	Yes	No
DS13	Weak battery	Red	Yes	No
DS14	Fail to start	Red	Yes	No
DS15	Low coolant temp	Red	Yes	No
DS16	Pre-high engine temp	Amber	Yes	No
DS17	High engine temp	Red	Yes	No
DS18	Pre-low oil pressure	Red	Yes	No
DS19	Low oil pressure	Red	Yes	No
DS20	Overspeed	Red	Yes	No

Typical installation

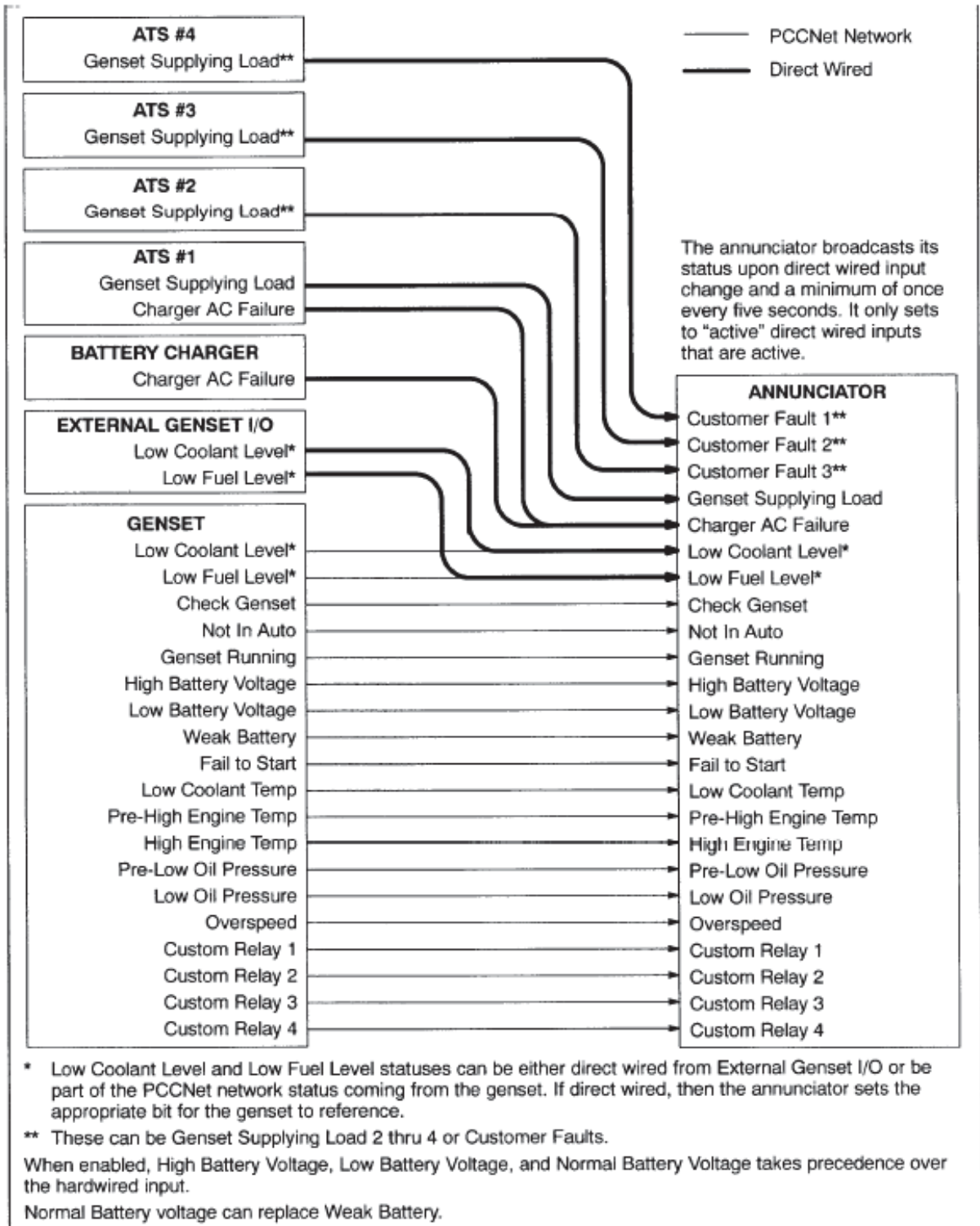

Dimensions

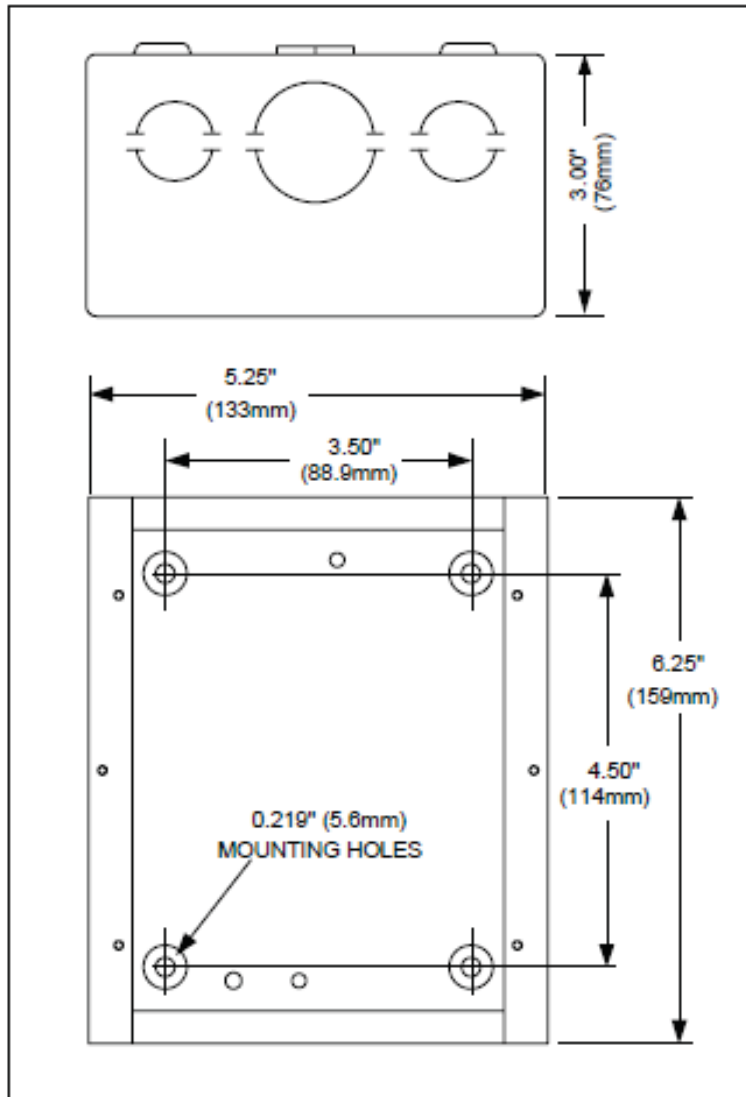

Dimensions: in (mm)

Ordering information

Part number	Description
0300-5929-01	Panel mount
0300-5929-02	Panel with enclosure

For more information contact your local Cummins distributor or visit power.cummins.com

Our energy working for you.™



PowerCommand[®] input/output expansion module **AUX 101** and **AUX 102**



Description

The PowerCommand AUX 101 input/output module and the AUX 102 input/output expansion module provide up to sixteen (16) relay output and up to twelve (12) discrete/analog inputs for auxiliary control and monitoring of the power system.

Analog/discrete inputs can be used for system fault expansion and/or generator set metering.

Relay outputs can be used for controlling equipment such as motors, louvers, lamps, fans and pumps. The relays may be configured individually from the genset control operator interface or using InPower™ software.

The AUX 101 and AUX 102 modules are compatible with genset controls supporting a PCCNet network and require a twisted pair connection. This includes the PCC 1301 control.

AUX 101 - Contains eight (8) Form-C relay output sets and eight (8) discrete/analog inputs.

AUX 102 - Easily connects to the AUX 101 to provide an additional eight (8) Form-C relay outputs and (4) additional discrete inputs.

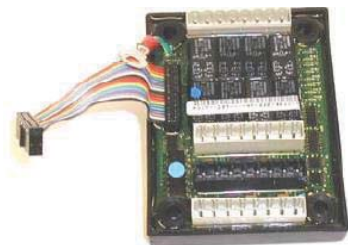

AUX 102 - Expansion

Features

- Up to sixteen (16) configurable Form-C relays provide easy control of system equipment such as lamps, louvers, motors and pumps. LED status of each relay.
- Up to twelve (12) configurable discrete inputs for monitoring equipment status and faults. Equipment status and faults will be annunciated.
- Up to eight (8) analog inputs. Analog inputs can be assigned one of seven preprogrammed functions:
 - Oil temperature
 - Exhaust temperature
 - Fuel level
 - Ambient temperature
 - Alternator RTD
 - Speed bias (for manual paralleling only)
 - Voltage bias (for manual paralleling only)
- Two 5 VDC voltage sources for use with active senders.
- Four programmable current sources for use with resistive senders.
- Two status LEDs:
 - DS1 (green) indicates the AUX 101 is connected to the network and operating normally
 - DS2 (red) indicates the AUX 101 has lost its connection or is not connected to the network
- Device number indicator. Seven segment LED used to uniquely define more than one AUX 101 on the same network.
- May be connected at any point in the PCCNet network.
- Plug-and-play networking - No binding required.
- Pluggable terminal blocks allow easy one-time wiring.
- Less wiring makes installation and system upgrades quick and easy
- PowerCommand controls are supported by a worldwide network of independent distributors who provide parts, service and warranty support.
- UL Listed and labeled; CSA certified; CE compliant.

Specifications

Signal requirements

Network connections: RS485, twisted-pair 78 kbps

Control power: 5-40 VDC

Current

- 200 mA typical at 12 V, no active relay
- 100 mA typical at 24 V, no active relay
- 800 mA at 12 V, all relays active

Terminations for control power accept wire up to 16 ga.

Environment

The AUX 101 and AUX 102 are designed for proper operation in ambient temperatures from -40 °C to +60 °C (-40 °F to +140 °F) and for storage from -40 °C to +80 °C (-40 °F to +176 °F). Modules will operate with humidity up to 95%, non-condensing

Configurations

All configurations are stored in the main genset control and are modified from the generator set control HMI or using InPower PC software.

Discrete/analog inputs:

Each AUX 101 input can be configured as discrete or analog. AUX 102 inputs are discrete only. Discrete inputs have the following configuration options:

- Active high or active low
- Event, warning or shutdown
- Programmable text (displayed on genset HMI and InPower software)

Analog inputs have a set of predefined functions and can only be configured on certain module inputs. Below is a list of functions and possible module inputs:

- Input 1 - Voltage bias (-3 to +3 VDC)*
- Input 2 - Speed bias (0 to +5 VDC)*
- Inputs 3 – 6
 - Oil temperature
 - Exhaust temperature
 - Ambient air temperature
 - Fuel level
 - Alternator temperature

Inputs are defaulted to disabled

* Please note that speed and voltage bias interfaces are for manual paralleling only and must not be used with automatic paralleling controls.

Relay ratings (AUX 101)

- Normally closed: 3 A at 250 VAC or 30 VDC
- Normally open: 5 A at 250 VAC or 30 VDC

Relay ratings (AUX 102)

- 2 A at 125 VAC, 2 A at 30 VDC

Input ratings (AUX 101)

- Active low inputs
- Maximum voltage 24 VDC (inputs 1 - 6)
- Maximum voltage 40 VDC (inputs 7 - 8)

Network length

Maximum 1219 m (4000 ft)

Approved wiring

Cat 4 or Cat 5 (stranded)

Relay outputs

Outputs can be configured to energize on occurrence of any event or fault code supported by the genset control. The relay outputs default to the following:

AUX 101

- 1 - Low oil pressure
- 2 - High engine temperature
- 3 - Charger AC failure
- 4 - Battery (low, weak, high)
- 5 - Engine overspeed
- 6 - Fail-to-start
- 7 - Not-in-auto
- 8 - Generator set running

AUX 102

- 9 - Pre-low oil pressure
- 10 - Pre-high engine temperature
- 11 - Low coolant level*
- 12 - Low fuel level*
- 13 - Low coolant temperature
- 14 - Common alarm
- 15 - Not defined
- 16 - Not defined

Dimensions

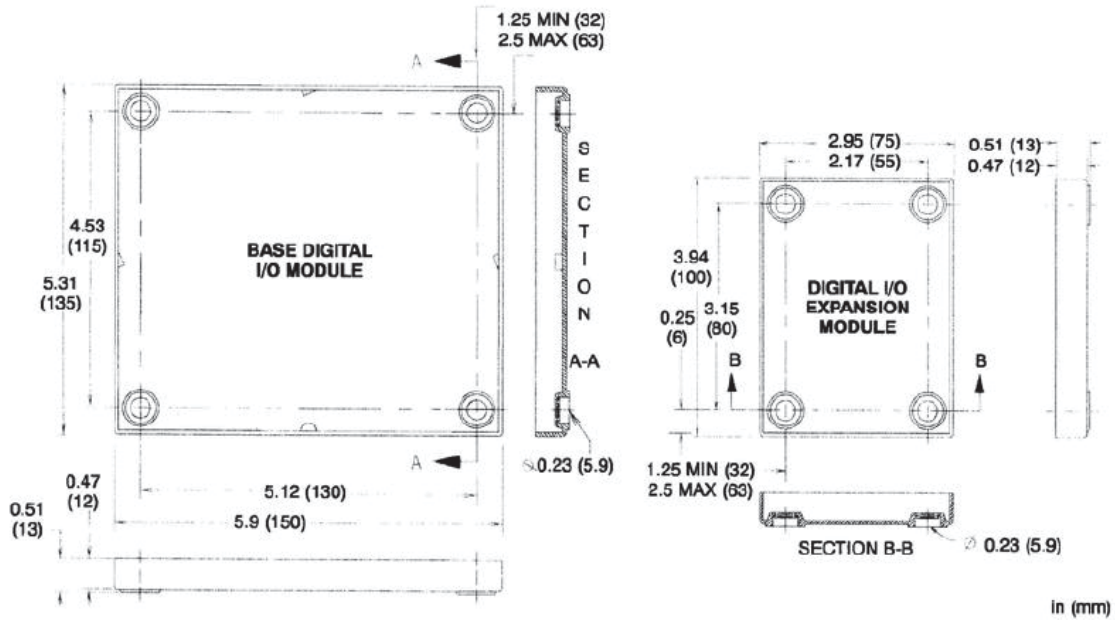

Ordering information

Part number	Description
A030K633	AUX101 Control Kit, 8 Discrete/Analog Input/ 8 Form-C Output-PCC 1.x/2.x/3.x
0184-0263	AUX 101 Digital Input/output Module - Base – PCC 1301 on DN and GN model generator sets
0630-3142	AUX 102 Digital Input/output Module wiring diagram - Instruction sheet C693
0541-0772	AUX 102 Digital Input/output Module - Expansion

PCCNet logo

Look for this logo on spec sheets of PCCNet compatible devices.



For more information contact your local Cummins distributor or visit power.cummins.com

Our energy working for you.™

©2017 Cummins Inc. All rights reserved. Cummins is a registered trademark of Cummins Inc. PowerCommand, AmpSentry, InPower and "Our energy working for you." are trademarks of Cummins Inc. Other company, product, or service names may be trademarks or service marks of others. Specifications are subject to change without notice. S-1503 (10/17)





PROTOCOL GATEWAY

Accessory specification sheet for Generator sets (GenSets) with Power Command Control (PCC) panels

THE SMART CHOICE FOR BUILDING MANAGEMENT SYSTEMS.

Designed for use with Cummins GenSets, the ProtoAir wireless gateway is an external, high-performance, low-cost building automation and industrial control IIoT gateway that enables new or legacy devices to easily interface with each other. Cummins technicians can use the ProtoAir to assist with GenSet maintenance and repair resulting in reduced support costs and improved customer service.

The ProtoAir for these GenSets offers:

- A **cost-effective, simple, and efficient** solution
- **Alarm** and event notifications
- **Minimal hardware** requirements
- **Standard connections** for Ethernet, RS-485, and RS-485/RS-232
- **Low-cost diagnostics** and troubleshooting support
- Fully **certified and approved** (see p. 2)
- A two-year comprehensive **warranty**

One ProtoAir connects multiple Serial and Ethernet devices to these field protocol networks (and more):

- BACnet MS/TP
- BACnet/IP
- Metasys N2
- SNMP
- XML over HTTP
- EtherNet/IP
- DNP 3.0



Critical component	Reference drawing
A059J208	A042H101

Specifications

Serial (Galvanic Isolation)	1 x RS-485/RS-232 & 1 x RS-485
Baud	9600, 19200, 38400, 57600, 76800, 115000
Ethernet	10/100BaseT, MDIX, DHCP
Operating temperature	-20 to 70°C (-4 to 158°F)
Relative humidity	10-95% RH non-condensing
Frequency	2.4 GHz
Channels	1 to 11 (inclusive)
Antenna type	SMA
Encryption	TKIP, WPA2 & AES
Dimensions	4 x 1.1 x 2.7 in. (10.16 x 2.8 x 6.8 cm)
Weight	0.4 lbs. (0.2 kg)
Input	24VAC 0.125A, 12-24VDC 0.25A
Maximum power	3W @ 12 VDC

Applicable codes and standards



The Underwriters Laboratory (UL) Listing is a comprehensive safety standard encompassing the design, construction, and performance of manufactured products.



The FCC mark is a voluntary mark employed on electronic products manufactured or sold in the United States which indicates that the electromagnetic radiation from the device is below the limits specified by the Federal Communications Commission and the manufacturer has followed the requirements of the Supplier's Declaration of Conformity authorization procedures.



The BTL Mark provides users with assurance that a product has passed the industry standard BACnet conformance tests conducted by a Recognized BACnet Testing Organization (RBTO).



Restriction of Hazardous Substances (RoHS) compliance restricts the use of six hazardous materials found in electrical and electronic products.



The DNP3 Conformance Logo indicates that an outstation has successfully passed the DNP3 Conformance Test Procedures and is listed on the DNP3 Users Group website.



Cummins Inc.
Box 3005
Columbus, IN 47202-3005
U.S.A.

1-800-CUMMINS™ (1-800-286-6467)
cummins.com

Printed in U.S.A.
©2024 Cummins Inc.

Ground fault indication relay - H550



> [Specification sheet](#)

Our energy working for you.™



Code requirements

NFPA 70, the U.S. National Electrical Code (NEC) requires that services of 1000 amps and larger in capacity which operate at more than 150 volts from line-to-neutral must be provided with ground fault equipment. Generator sets rated at 1000 amps and larger which serve as emergency power must be provided with ground fault indication equipment. Health care facilities that utilize ground fault protection equipment must be provided with a coordinated multi-level ground fault system.

Cummins Power Generation ground fault indication equipment is designed for use in emergency/standby power systems, for indication of ground fault conditions during generator set operation.

Features

Suitable for indicating a ground fault condition on a generator set which is either locally or remotely grounded.

Supply voltage - Operates on 24 VDC (nominal) control power - fully functional at voltages from 18-30 VDC.

Direct connection - Suitable for direct connection to generator sets operating at voltages up to 600 VAC (line to line).

Ground fault current settings - 100-1200 A, in 10 discrete settings: 100, 150, 200, 250, 300, 450, 600, 750, 800, 1200 A.

Monitoring - Provides continuous monitoring of neutral-to-ground with LED indication for open connection.

Factory mounted controls - Available factory-mounted and interconnected to Cummins Power Generation Detector™ series PowerCommand® controls.

Link reconnection - For use with either 3-pole (solid neutral) or 4-pole (switched neutral) transfer switches.

Indicating lamps - For Relay on (green), ground fault current over setting (red), loss of ground connection (red).

Time delay settings – Adjustable 0-10 seconds.

Circuit board - One-piece molded case fully potted.

Contacts - One set of form C output, 8A at 250 VAC, 8A at 30 VDC.

“Test” - Push-button.

“Reset” - Push-button.

Percent full scale metering output - 0-1 mA full scale.

Bonding jumper - Sized per NEC requirements.

Construction

The relay is provided in a non-conducting phenolic case, with provisions for panel mounting or mounting to a standard DIN rail (panel mounting is recommended for mounting on a generator set). Relay components are fully potted with epoxy resin for vibration resistance and durability.

The relay includes an integral terminal block assembly, which accepts wires up to 12-gauge.

Relay function selection link (auto/hand reset).

Environmental range - Operating -10 °C to +60 °C, storage -20 °C to 70 °C.

DC supply burden – 2.5 W.

Transfer switch type selection link - (3-pole or 4-pole).

System operation

The ground fault relay continuously monitors the voltage across the neutral-to-ground bonding jumper and lights the ground fault alarm lamp on the generator set control when the connection is broken.

When the generator set is running, the relay continuously monitors the neutral-to-ground generator set connection and lights the ground fault alarm lamp on the generator set control when a ground fault condition is sensed.

Alarm condition can be cleared by pushing the reset switch on the generator set control panel. Actual ground fault current level can be monitored with a 0-1 mA meter, directly from the relay. A push button test switch is provided to simulate ground fault conditions and operate the relay and indication circuitry. Addition of the auto-reset link activates automatic reset of the relay after the ground fault condition has cleared.

System schematic

Separately derived system connections (local grounding connection).

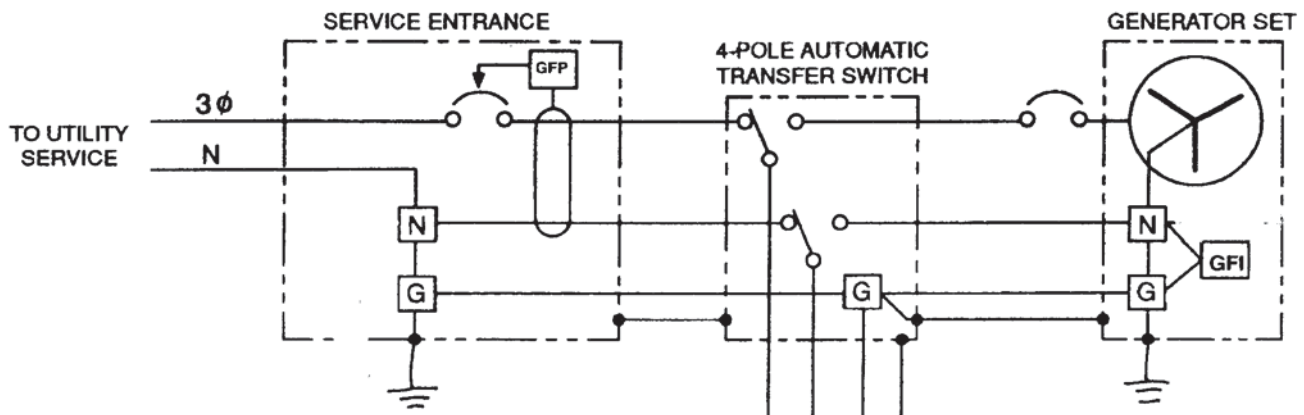

Neutral-to-ground bonding jumper must be sized per code requirements. For non-separately derived systems (3-phase/4-wire systems with 3-pole transfer switch), the ground connection and the neutral-to-ground bonding jumper on the generator set are removed, and the 3-pole ATS link is added to the ground fault relay. For non-separately derived systems a label must be applied to the service entrance switchboard, indicating that removal of the equipment-bonding jumper can cause hazardous operating conditions.

Feature descriptions

H550-2 = The unit is equipped with an adjustable sensor to detect a ground fault condition on the main alternator output. A fault condition illuminates an indicating lamp on the genset control panel. Sensor features include: -0 to 1.0 second adjustable time delay. Ground fault pickup settings: 100, 150, 200, 250, 300, 450, 600, 750, 800, 1200 Amps – “Test” and “Reset” buttons and functional condition indicating lights. Suitable for operating voltages up to 600 VAC.

Our energy working for you.™

www.cumminspower.com

©2009 Cummins Power Generation Inc. All rights reserved. Cummins Power Generation and Cummins are registered trademarks of Cummins Inc. “Our energy working for you.”, PowerCommand and Detector are trademarks of Cummins Power Generation. Specifications are subject to change without notice.
AC-160e (9/09) Page 2 of 8



Outline detail

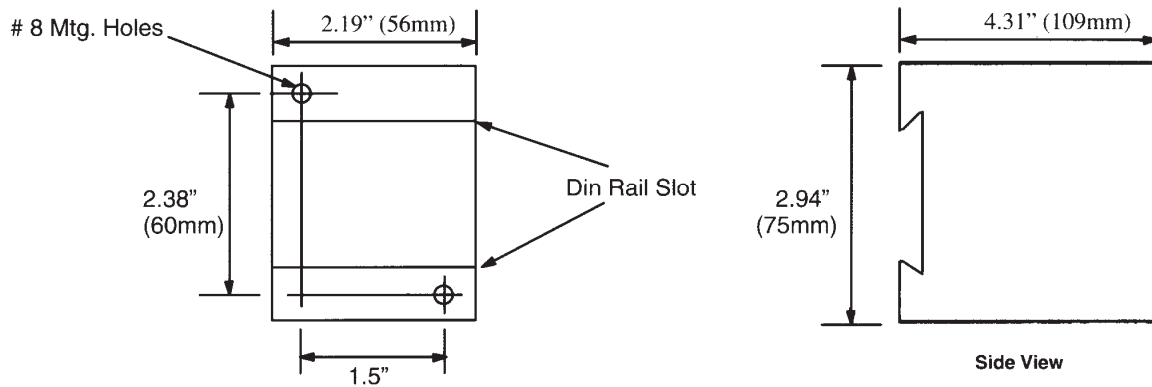

Weight: 19 oz (540 grams)

Interconnection detail

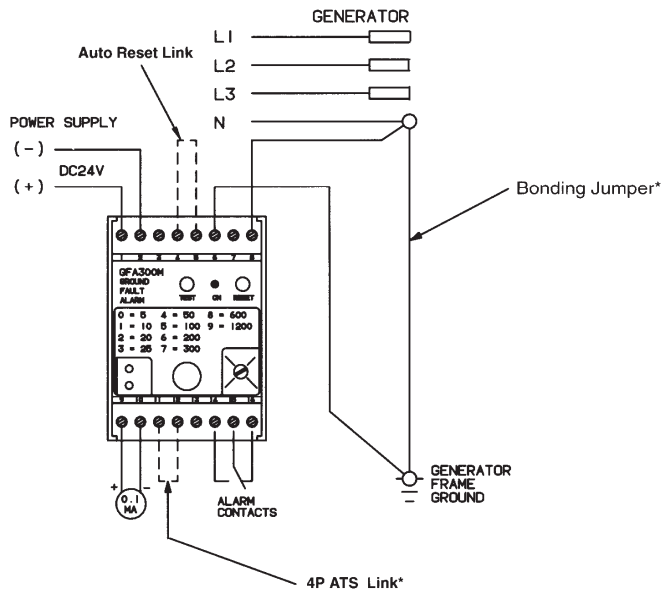

* Required only with separately derived systems. Bonding jumper is included in kit.

Our energy working for you.™

www.cumminspower.com

©2009 Cummins Power Generation Inc. All rights reserved. Cummins Power Generation and Cummins are registered trademarks of Cummins Inc. "Our energy working for you.", PowerCommand and Detector are trademarks of Cummins Power Generation. Specifications are subject to change without notice.
AC-160e (9/09) Page 4 of 8



REV.	DATE	BY	CHKD	DESCRIPTION	DATE	BY	CHKD	DESCRIPTION
1	01-26-03	FRD	FRD	ISSUE FOR PRODUCTION RELEASE	01-26-03	FRD	FRD	ISSUE FOR PRODUCTION RELEASE
2	01-26-03	FRD	FRD	UPDATE SCHEMATIC	01-26-03	FRD	FRD	UPDATE SCHEMATIC
3	01-26-03	FRD	FRD	UPDATE SCHEMATIC	01-26-03	FRD	FRD	UPDATE SCHEMATIC

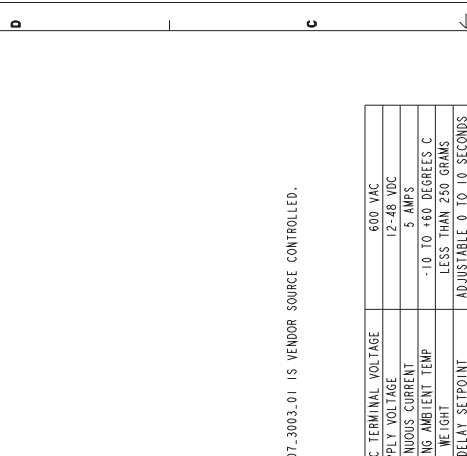

NOTES:
 1. PART 0307_3003_01 IS VENDOR SOURCE CONTROLLED.

MAXIMUM AC TERMINAL VOLTAGE	600 VAC
SUPPLY VOLTAGE	12-48 VDC
CONTINUOUS CURRENT	5 AMPS
OPERATING AMBIENT TEMP	-10 TO +60 DEGREES C
WEIGHT	LESS THAN 250 GRAMS
TIME DELAY SETPOINT	ADJUSTABLE 0 TO 10 SECONDS
TIP CURRENT SETPOINT	100/150/200/250/300/450/600/750/800/1200 AMPS
BURDEN	LESS THAN 1.5 WATTS
RESPONSE TIME	LESS THAN 200 MS
RATED CONTACT VOLTAGE	8 AMPS AT 250 VAC
RATED CONTACT VOLTAGE	8 AMPS AT 30 VDC

TABULATION	
PART NO.	CURRENT LER
0307_3003_01	FRD17650
0307_3003_02	FRD17650

THIS IS A CONTROLLED PRODUCT.
 TO WHOMSOEVER IT MAY CONCERN:
 This drawing is the property of Cummins Power Generation. It is to be used only for the purpose intended and is not to be reproduced, stored in a retrieval system, or transmitted in any form or by any means, electronic, mechanical, photocopying, recording, or by any information storage and retrieval system, without the prior written permission of Cummins Power Generation. The user of this drawing shall be responsible for obtaining all necessary rights and clearances for its use. This drawing is the property of Cummins Power Generation and is not to be used for any other purpose without the prior written permission of Cummins Power Generation.

0307_3003_01 ONLY

0307_3003
 Pro/ENGINEER METRIC DWG

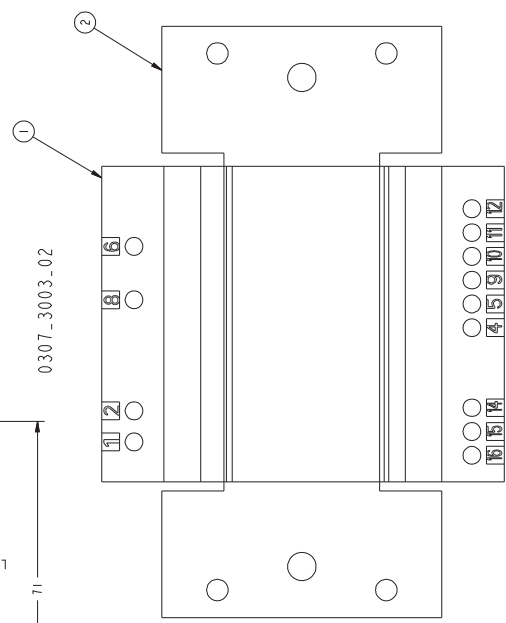
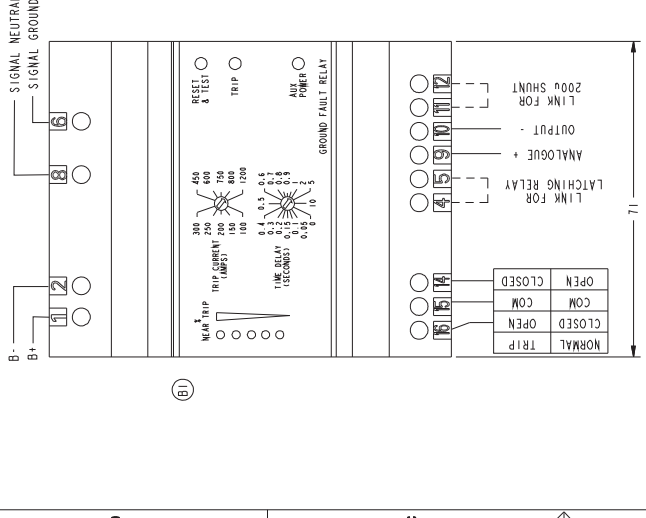

REV.	DATE	BY	CHKD	DESCRIPTION	DATE	BY	CHKD	DESCRIPTION
1	01-26-03	FRD	FRD	ISSUE FOR PRODUCTION RELEASE	01-26-03	FRD	FRD	ISSUE FOR PRODUCTION RELEASE
2	01-26-03	FRD	FRD	UPDATE SCHEMATIC	01-26-03	FRD	FRD	UPDATE SCHEMATIC

DO NOT SCALE PRINT	DATE: 01-26-03	TIME: 10:00 AM	USER: FRD
PLANT: 0307	PROJECT: 0307_3003_01	DWG NO: 0307_3003_01	REV: 1
DESIGNER: FRD	CHECKER: FRD	APPROVER: FRD	DATE: 01-26-03
CUMMINS POWER GENERATION	1500 N. BRUNNEN DRIVE	SPRINGFIELD, IL 62777	USA
PG: 0307_3003_01	PG: 0307_3003_01	PG: 0307_3003_01	PG: 0307_3003_01

AGN 227 – Anti-Condensation Heaters

DESCRIPTION

The type of anti-condensation heater used in an AvK or STAMFORD alternator is dependent on the alternator model and size. The anti-condensation heater could be a Cartridge, Flexible Pad or Circular Ring type. All of these anti-condensation heater types are designed to combat moderate humidity levels over periods of alternator inactivity. They are not to be used when the alternator is in use.

Anti-condensation heaters reduce the moisture level in the air immediately around the alternator when the alternator is stationary. They also maintain the atmosphere inside the alternator above the dew point during long periods of inactivity, such as when the alternator is used in a standby application.

If a situation exists where humidity levels are known to be high, the accepted way of dealing with this situation is to install space heaters around the Generating Set, in the canopy or room, combined with motorised ventilation louvres to shut out the damp atmosphere.

The design criteria for anti-condensation heaters used on AvK and STAMFORD alternators was to support an insulation system by maintaining sufficient residual temperature within an alternator that has just completed an operation (run) to stop condensation forming or being absorbed during the inactive period. The actual heater wattage is a compromise of design requirement and the space available within the non-drive end (NDE) area of the alternator.

Anti-condensation heaters are NOT adequate for drying out an alternator.

A separate power supply is required for the anti-condensation heaters. Customers usually arrange a power supply connection that automatically switches on when the Generating Set is

shut down. The anti-condensation heaters can operate at various voltages. The heater wattage and number of anti-condensation heaters also vary depending on the alternator frame size.

ANTI-CONDENSATION HEATER TYPES

Refer to Drawing number A12-H11 for the anti-condensation heater connection details.

S0L1 / S0L2 Alternators

The Flexible Pad type heater is pasted on a curved bracket and the bracket is bolted to the alternator's Non-Drive End (NDE) bracket, below the exciter assembly.

There are four options for the anti-condensation heater depending on the supply voltage: 12 VDC, 24 VDC, 115 VAC and 230 VAC. The heater output powers are 30W for S0L1 and 45W for S0L2.

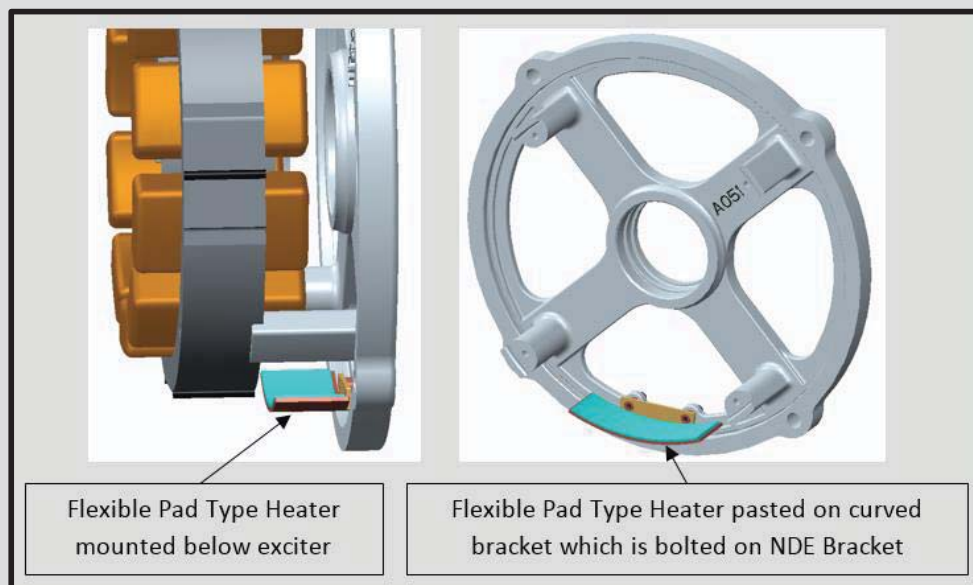

Heater options for the S0L1 are (Drawing A12-H11):

- 12V (DC); 30 Watts
- 24V (DC); 30 Watts
- 115V (AC); 30 Watts
- 230V (AC); 30 Watts

Heater options for the S0L2 are (Drawing A12-H11):

- 12V (DC); 45 Watts
- 24V (DC); 45 Watts
- 115V (AC); 45 Watts
- 230V (AC); 45 Watts

S1L2 Alternators

The Cartridge type heater is mounted on the alternator's NDE bracket, below the exciter assembly.

There are four options for the anti-condensation heater depending on the supply voltage: 12 VDC, 24 VDC, 115 VAC and 230 VAC. The heater output power is 80W.

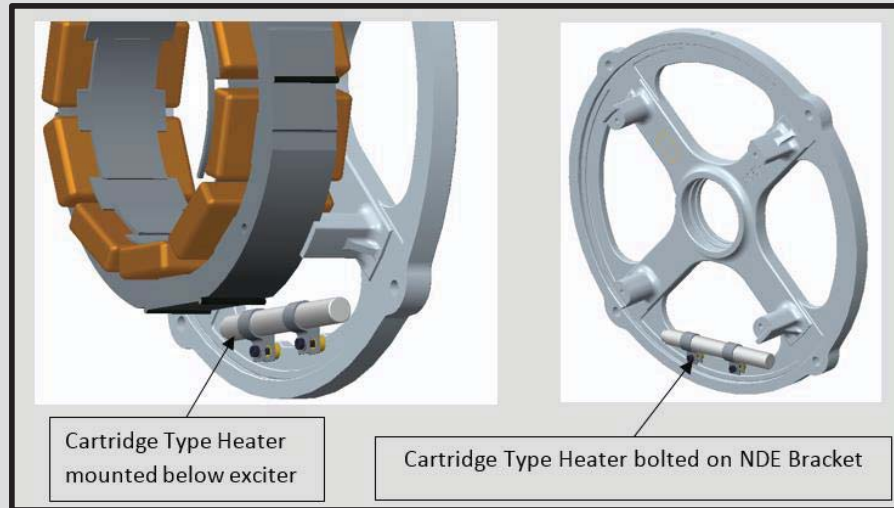

Heater options for the S1L2 are (Drawing A12-H11):

- 12V (DC); 80 Watts
- 24V (DC); 80 Watts
- 115V (AC); 80 Watts
- 230V (AC); 80 Watts

P0/P1 Alternators

The Flexible Pad type heater element is secured to the NDE Bracket and below the exciter windings. There are four options for the anti-condensation heater depending on the supply voltage: 12 VDC, 24 VDC, 115 VAC and 230 VAC. The heater output power is 30W.

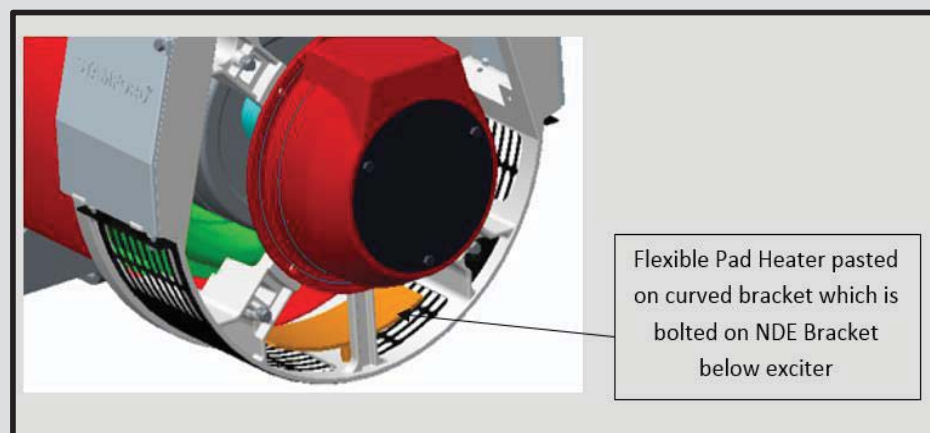

Heater options for the P0/P1 are (Drawing A12-H11):

- 12V (DC); 30 Watts
- 24V (DC); 30 Watts
- 115V (AC); 30 Watts
- 230V (AC); 30 Watts

UC 22 (S2) Alternators

The UC 22 (S2) alternators have a 1 element cartridge heater and there are 2 options:

- 1 element: 110 to 125V; 90 to 115W (Drawing A7-H11 Fig 1)
- 1 element: 220 to 260V; 90 to 125W (Drawing A7-H11 Fig 1)

UC 27 (S3) Alternators

The UC 27 (S3) alternator have a 1 element cartridge heater and there are 2 options:

- 1 element: 110 to 125V; 90 to 115W (Drawing A7-H11 Fig 1)
- 1 element: 220 to 260V; 90 to 125W (Drawing A7-H11 Fig 1)

S4 Alternators

The S4 alternators have has a 2 element cartridge heater and there are 3 options:

- 2 elements in parallel (standard): 110 to 125V; 250 to 325W (Drawing A7-H11 Fig 2)
- 2 elements in parallel (standard): 220 to 260V; 250 to 350W (Drawing A7-H11 Fig 2)
- 2 elements in parallel (higher power option): 220 to 277V; 450 to 715W (Drawing A7-H11 Fig 2)

On the UC 22 (S2), UC 27 (S3) and S4 alternators, the heaters are mounted underneath the Main Stator windings at the NDE (Non-Drive End), at the bottom of the frame:

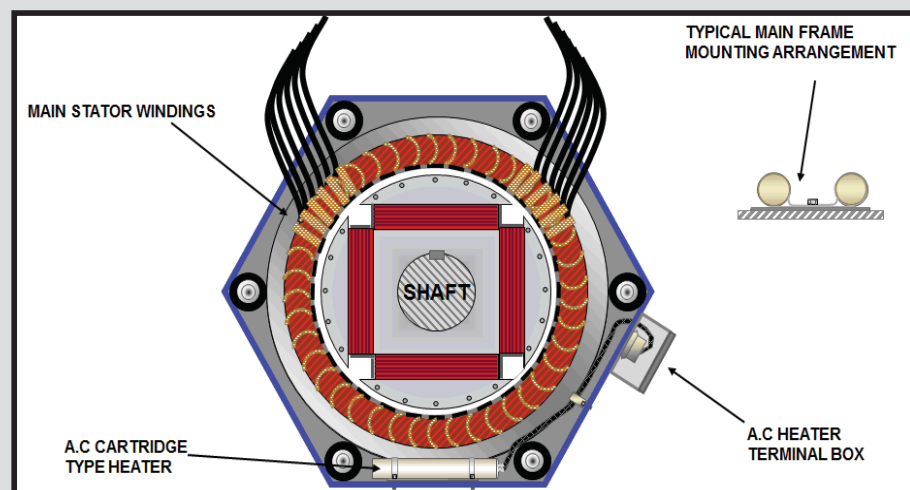

HC5 (S5) Alternators

The HC5 (S5) alternators have options for 1 element or 2 element cartridge heaters:

- 1 element (standard): 110 to 138V; 225 to 355W (Drawing A7-H11 Fig 1)
- 1 element (standard): 220 to 277V; 225 to 360W (Drawing A7-H11 Fig 1)
- 2 elements in parallel (option): 220 to 277V; 450 to 715W (Drawing A7-H11 Fig 2)
- 2 elements in series (option): 440 to 554V; 450 to 715W (Drawing A7-H11 Fig 4)

S6 Alternators

The S6 alternators have options for 1 element or 2 element cartridge heaters:

- 1 element (standard): 110 to 138V; 225 to 355W (Drawing A7-H11 Fig 1)
- 1 element (standard): 220 to 277V; 225 to 360W (Drawing A7-H11 Fig 1)
- 2 elements in parallel (option): 220 to 277V; 450 to 715W (Drawing A7-H11 Fig 2)
- 2 elements in parallel (option): 250 to 305V; 450 to 670W (Drawing A7-H11 Fig 2)

P7 (S7) Alternators

The P7 (S7) alternators have either 2 element or 4 element cartridge heaters, depending on the core length:

- P7A-F: 2 elements in parallel: 110 to 138V; 450 to 710W (Drawing A7-H11 Fig 2)
- P7A-F: 2 elements in parallel: 220 to 277V; 450 to 715W (Drawing A7-H11 Fig 2)
- P7G-H: 4 elements in parallel: 110 to 138V; 900 to 1415W (Drawing A7-H11 Fig 3)
- P7G-H: 4 elements in parallel: 220 to 277V; 900 to 1425W (Drawing A7-H11 Fig 3)

On the HC5 (S5), S6 and P7 (S7) alternators, the heaters are mounted on a bracket, which is then bolted on the Exciter Stator core pack:

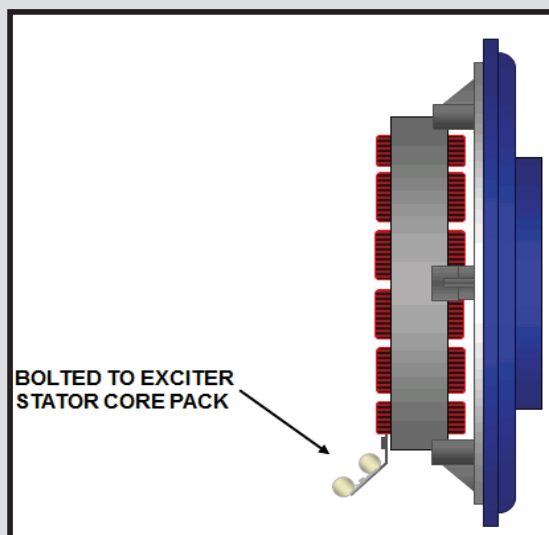

P80 (S8/S9) Alternators

The P80 (S8/S9) alternators have two circular ring tubular heaters, which can be connected either in series or in parallel. There are specific ranges for the heater output power depending on the voltage applied to the heaters. Heaters are mandatory and therefore fitted as standard on Medium and High Voltage P80 alternators (MV80/ HV80).

When connected in parallel, the voltage operating range across the two heaters is 100 to 138V, resulting in output power of 1062W to 2022W.

When connected in series, the voltage operating range across the two heaters is 200V to 277V, resulting in output power of 1058W to 2029W.

The output power range corresponds to the minimum and maximum supply voltages. So for example, if 200V was applied across the two heaters, the power output would be 1058W, and if 277V was applied across the two heaters, the power output would be 2029W.

Any operating voltage between 200V and 277V requires a calculation to determine the output power. For example, heaters operating at 220V: $(220^2 / 200^2) \times 1058W = 1280W$.

The supply voltage range of the heaters is specified by the customer during the alternator order placement. The heaters will then be connected based on customer's specification (in series or in parallel) and the wiring diagram will reflect the voltage and output power range of the heaters. Instead of having a separate heater connection diagram, the heater connection is included in the complete Wiring Diagram for a P80 alternator.



AvK DSG/DSU/DIG Alternators

Anti-condensation heaters are fitted on every DSG/DSU/DIG alternator. The output power of the heaters depends on the alternator frame size. There is also the option to select heaters with increased output powers depending on the application needs.

Alternator	Alternator Type	Heater Output Power (Standard)	Heater Output Power (Optional)
DSG/ DSU	62, 74	350W	N/A
	86, 99	500W	1000W
	114	1000W	1500W
DIG	110, 120, 130	500W	1000W
	140, 142	1000W	1500W

There are several supply voltage options for the heaters. Other supply voltages not listed below can also be considered on a case-by-case basis:

- 120V, 1-phase, AC/DC
- 230V, 1-phase, AC/DC
- 400V, 1-phase, AC/DC
- 480V, 1-phase, AC/DC
- 230V, 3-phase
- 400V, 3-phase
- 480V, 3-phase
- 600V, 3-phase

The anti-condensation heaters are generally mounted at the non-drive-end (NDE) of the alternator, below the exciter stator assembly:

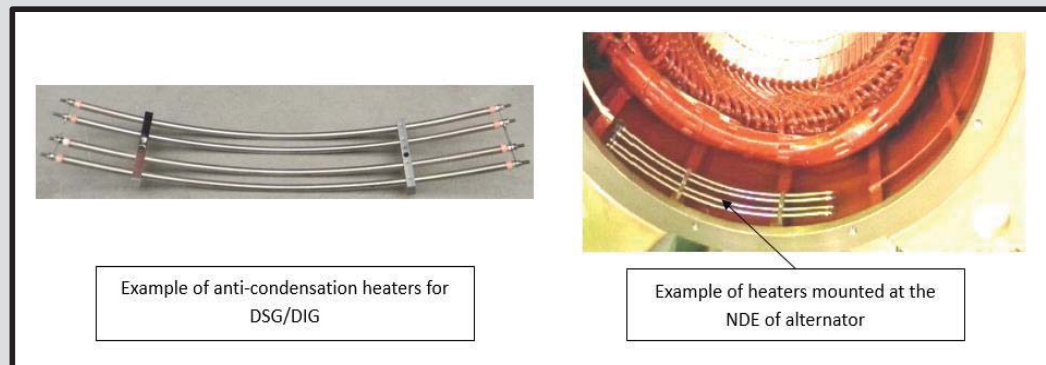



COOLANT HEATER

Accessory specification sheet for 1000-1300 kW Natural gas generator sets (GenSets)

THE SMART CHOICE FOR GENSET ENGINE PERFORMANCE.

Regulating the coolant temperature reduces engine wear caused by cold engine starting. Optimize the performance of your GenSet with a coolant heater that uses pump-driven forced circulation to provide superior heat distribution. This natural gas GenSet coolant heater includes a thermostat, pump, and all required controls.



A Cummins 1000-1300 kW natural gas GenSet only requires one 12,000 watt coolant heater.

GenSet model	Coolant heater specifications			
	Required power supply		Heating system	
	Voltage*	Phase	Critical component	Reference drawing
C1000N6B	240	1	CSM11202-000	A067X926
	208	3	CSM31208-000	A067G754
	480	3	CSM31204-000	A066E112
C1300N6	240	1	CSM11202-000	A067X926
	208	3	CSM31208-000	A067G754
	480	3	CSM31204-000	A066E112

*Coolant heater input voltages are NOT field configurable.

Outline drawing

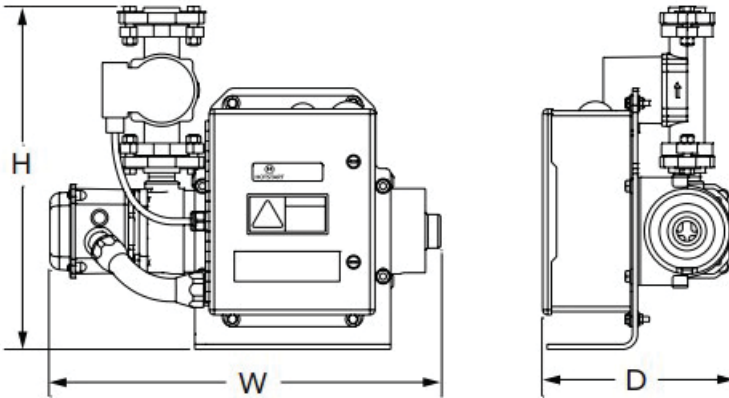

Height in. (cm)	Width in. (cm)	Depth in. (cm)
17 (43.2)	19.4 (49.3)	9.5 (24)

NOTE: Refer to the GenSet general arrangement drawing for the heater location and the GenSet installation manual for the termination details.

Weight: 54 lbs. (24.5 kg)

Applicable codes and standards

ISO 9001:2015

This product has been manufactured under the controls established by an approved management system that conforms with ISO 9001:2015.



The Underwriters Laboratory (UL) 2200 Listing is a comprehensive safety standard encompassing the design, construction, and performance of manufactured products.



Conformité Européene (CE) compliant to the health and safety requirements of relevant European directives: LVD 2006/95/EC, EMC 2004/108/EC and PED 97/23/EC.





LUBE OIL HEATER

Accessory specification sheet for 1000-1300 kW Natural gas generator sets (GenSets)

THE SMART CHOICE FOR GENSET ENGINE PERFORMANCE.

Optimize the performance of your GenSet in colder climates with a lube oil heater that provides uniform heating to the oil throughout the engine oil sump and external piping, enhancing engine availability during cold startups. This lube oil heater heating chamber and oil pump heats and circulates the oil so that upon GenSet start-up, warm oil is supplied to the critical wear points in the engine. This reduces engine wear and allows easier starts which prolong battery life.



Specifications

A Cummins 1000-1300 kW natural gas GenSet only requires one 2000 watt lube oil heater.

GenSet model	Oil heater specifications				
	Required power supply		Heating system		
	Voltage*	Phase	Amps	Critical component	Reference drawing
C1000N6B	240	1	11.3	OSM1020208-000	A067X929
	208	3	8	OSM3020808-000	A067G852
	480	3	3.2	OSM3020410-000	A066E111
C1300N6	240	1	11.3	OSM1020208-000	A067X929
	208	3	8	OSM3020808-000	A067G852
	480	3	3.2	OSM3020410-000	A066E111

*Oil heater input voltages are NOT field configurable.

Outline drawing

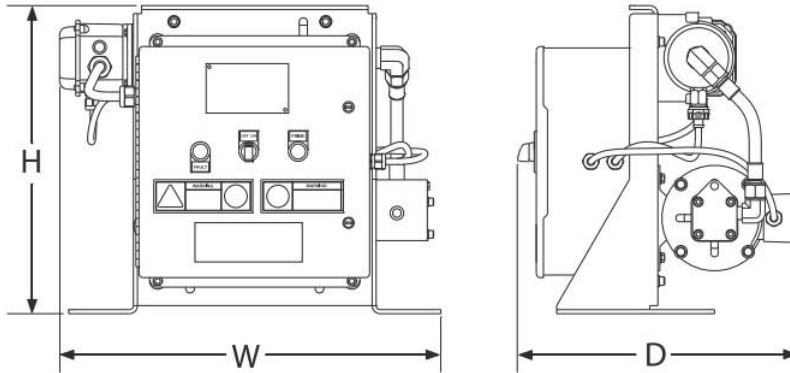

Height in. (cm)	Width in. (cm)	Depth in. (cm)
19 (48.3)	23 (58.4)	17.3 (44)

NOTE: Refer to the GenSet general arrangement drawing for the heater location and the GenSet installation manual for the termination details.

Weight: 100 lbs. (45 kg)

Applicable codes and standards



The Underwriters Laboratory (UL) 2200 Listing is a comprehensive safety standard encompassing the design, construction, and performance of manufactured products.



Conformité Européene (CE) compliant to the health and safety requirements of relevant European directives: LVD 2006/95/EC, EMC 2004/108/EC and PED 97/23/EC.





GAS TRAIN ACCESSORIES

Accessory specification sheet for Natural gas generator sets (GenSets)

Proper gas train design is essential to the performance of any gaseous-fueled generator set. Cummins offers strainers and flexible connections in the absence of a pre-designed gas train system.

Gas/Fuel Strainers

Y- (WYE) strainers are installed in a piping system to remove unwanted debris from the pipeline, protecting equipment downstream such as pumps, meters, spray nozzles, compressors, and turbines. They can be placed in a horizontal or vertical pipeline as long as the screen is in a downward position. Straining is accomplished via an internal perforated or mesh lined straining element, the size of which should be determined based on the size of the smallest particle to be removed.

Flexible Connectors

The corrugated metal hoses have a 321 stainless-steel inner hose and a 304 stainless-steel braided cover. 321 stainless steel can withstand very high temperatures and has high strength, resists scaling, and provides phase stability with resistance to subsequent aqueous corrosion. 304 stainless steel can be sanitized and can withstand corrosion from most oxidizing acids but is susceptible to corrosion from chloride solutions or from high-saline environments like coastal regions.



Gas Train Accessory Applications

Genset Model	C200N6	C250N6 C300N6	C350N6	C400N6 C450N6 C500BN6B	C550N6	C600N6 C650N6 C750N6	C1000N6B C1300N6
Gas/Fuel Strainer	149-0751	149-0751	A059G917	A059G917	A076D342	A076D342	A059G917
Flexible Connector	MM-2-15	MM-2-15	MM-3-24	A063Z507	A067G635	A067G635	22837-07
Flex Conn (CSA)	22837-05	22837-05	22837-07	A063Z508	A067G635	A067G635	22837-07

Gas/Fuel Strainer

149-0751 / A059G917

400 PSI @ 150 °F

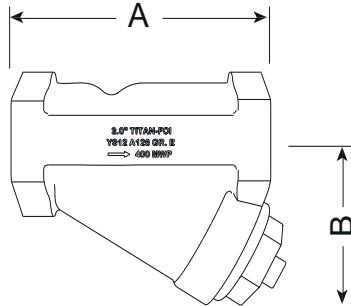

A076D342

200 PSI @ 150 °F

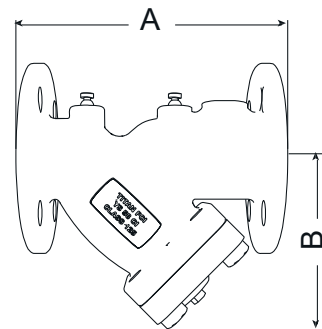

Part Number	Fitting Size	Dim "A"	Dim "B"
149-0751	2.00"	7.00"	4.75"
A059G917	3.00"	10.00"	6.00"
A076D342	4.00"	12.12"	8.25"

Flexible Connector

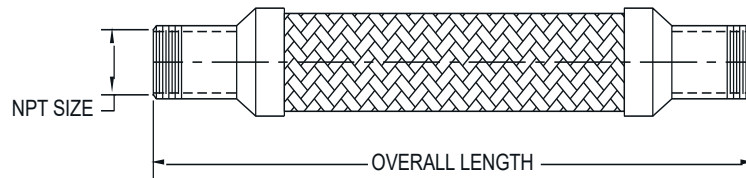

Part Number	CEN-FLEX/FLEXTECH #	NPT Size	Overall Length
12800-06	MM-2-15	2.00"	15.00"
12800-08	MM-3-24	3.00"	24.00"
*22837-05	FTG-32-A-CS-15	2.00"	15.00"
*22837-07	FTG-48-A-CS-24	3.00"	24.00"

Hose assemblies (12800-xx) rated at:

792 psi for 0.75" hose
 571 psi for 1.00" hose
 518 psi for 2.00" hose

Hose assemblies (22837-xx) rated at:

350 psi for 0.50" to 2.00" hose
250 psi for 2.50" to 3.00" hose
 200 psi for 4.00" to 6.00" hose

*CSA approved flex assemblies. To be marked with tag showing CSA approval.

Applicable codes and standards



The Underwriters Laboratory (UL) Listing is a comprehensive safety standard encompassing the design, construction, and performance of manufactured products.



The CSA Group Listing indicates that the product was tested and has met the certification requirements for electrical, plumbing and/or mechanical products.



30.5 mm Push Buttons

Product Overview



Bulletin 800T/800H 30.5 mm Push Buttons

- 30.5 mm mounting hole
- Type 4/13 watertight/oiltight (Bul. 800T)
- Type 4/4X/13 corrosion-resistant/watertight/oiltight (Bul. 800H)
- Heavy industrial stations and operators

Description

The Allen-Bradley Bulletin 800T and 800H 30.5 mm push button product lines are in a class by themselves. They are designed and constructed to perform in the most demanding industrial environments. In terms of sealing and switching performance, you will not find a more dependable push button offering. Allen-Bradley delivers more styles and options of operator types and contact blocks, offering flexibility to meet the most demanding specifications in the world's toughest industrial environments.

Design innovation is key to the performance advantage provided in the Bulletin 800T and 800H offerings. New in this catalog are the **Trigger Action E-Stop** operators, the new standard bearer in a tamper-resistant design. Also new is the **Universal LED Illumination** option that accepts a wide 12...130V AC/DC voltage input. This is compatible with all illuminated operator types, allows retrofitting in existing installations, and incorporates super bright LED technology.

Table of Contents

See below.

Standards Compliance

UL 508

CCC

Certifications

UL Listed
(File No. E14840, E10314
Guide No. NKCR, NOIV)

CSA Certified
(File No. LR1234, LR11924)

CSA C22.2, No. 14

EN/IEC: 60947-5-1

TABLE OF CONTENTS

Description	Page	Description	Page
Specifications	10-3	Specialty Operators	
Assembled Stations	10-5	Potentiometer	10-25
DeviceNet Stations	10-6	Mechanically Interlocked Push Button	10-25
Trigger Action E-Stops	10-7	Cluster Pilot Light.....	10-26
Push Buttons, Momentary		18 mm Small Pilot Light	10-27
Non-Illuminated.....	10-9	1-, 2-, 3-, 4-Way Toggle Switch	10-28
Illuminated.....	10-10	Selector Push Button.....	10-29
Non-Illuminated — with Two-Color Molded Legend Cap	10-11	Cylinder Lock Push Button	10-30
Selector Switches, Non-Illuminated		Padlocking Mushroom Head	10-30
2-Position	10-12	Wobble Stick.....	10-30
3-Position	10-14	Flip Lever Operator.....	10-31
4-Position	10-16	Break-Glass Push Button Station	10-32
Selector Switches, Illuminated		Custom-Built Stations	10-33
2-Position	10-18	Enclosures	10-33
3-Position	10-19	Accessories	
Pilot Light Devices	10-20	Contact Blocks.....	10-35
Emergency Stop Operators		Power Modules and Universal LED Module.....	10-36
Push-Pull, Non-Illuminated		Replacement Color Caps.....	10-37
2-Position.....	10-21	Selector Switch Knobs.....	10-38
3-Position.....	10-22	Protective Boots	10-39
Push-Pull, Illuminated		Push Buttons & Miscellaneous	10-40
2-Position.....	10-23	Locking Attachments.....	10-42
3-Position.....	10-24	Guards	10-44
		Replacement Lamps	10-45
		Replacement Keys.....	10-46
		Legend Plates.....	10-47
		Approximate Dimensions & Shipping Weights	10-53
		Typical Pilot Light Wiring Diagram	10-65



Specifications*

Electrical Ratings		
Contact ratings	Refer to the contact ratings tables on page 10-4.	
Dielectric strength	2200V for one minute, 1300V for one minute (Logic Reed)	
Electrical design life cycles	1 000 000 at max. rated load, 200 000 at max. rated load (Logic Reed)	
Mechanical Ratings		
Vibration	10...2000 Hz, 1.52 mm displacement (peak-to-peak) max./ 10 G max. (except Logic Reed)	
Shock	1/2 cycle sine wave for 11 ms \geq 25 G (contact fragility) and no damage at 100 G	
Degree of protection	Type 1/4/12/13 (800T); Type 1/4/4X/12/13 (800H); EN/IEC 60529 IP66/65	
Mechanical design life cycles		
Push buttons	(Momentary, non-illuminated)	10 000 000 min.
	(Momentary, illuminated)	250 000 min.
	(Push-pull/twist-to-release)	250 000 min.
Selector switches	(Non-illuminated)	1 000 000 min.
	(Illuminated, key-operated)	200 000 min.
Potentiometers	25 000 min.	
All other devices	200 000 min.	
Contact operation	Shallow, mini, and low-voltage contact blocks: Slow, double make and break Logic Reed and sealed switch contact blocks: Single break magnetic	
Wire gauge/Terminal screw torque	#18...14 AWG (#18...10 Max Duty) / 6...8 lb•in	
Typical operating forces		
Operators without contact blocks	Flush, extended button, standard mushroom, jumbo plastic mushroom: 2 lbs max. Jumbo and extended aluminum mushroom head: 3.95 lbs max. Maintained selector switch: 3.6 in•lb max.	
Spring return selector switches	3.6 in•lb to stop, 0.2 in•lb to return	
Illuminated push buttons and push-to-test pilot lights	5 lb max.	
2-position push-pull	8.0 lb max. push or pull	
3-position push-pull	8 lb max. push to in position or pull to center position (15 lb max. pull to out position)	
Twist-to-release or push-pull	9 lbs max. push or pull 30 in•oz max. twist, 6 in•oz minimum return	
Potentiometer	Rotational torque 3...12 in•oz; stopping torque 12 in•lb (minimum)	
Contact blocks	Standard	1 lb
	Logic Reed	1 lb max.
	Sealed switch	3 lb max. at 0.205 in. plunger travel
	Stackable sealed switch	1 lb max.
	MaxDuty	1.4 lb max.
	PenTUFF	1.4 lb max.
Self Monitoring	1.6 lb	
Environment		
Temperature range	Operating	-40...+131 °F (-40...+55 °C)
	Storage	-40...+185 °F (-40...+85 °C)
Note: Operating temperatures below freezing are based on the absence of moisture and liquids. Consult your local Rockwell Automation sales office or Allen-Bradley distributor for use in lower temperature applications.		
Humidity	50...95% RH from 77...140 °F (25...60 °C) per Procedure IV of MIL-STD-810C, Method 507.1 cycling test	

* Performance Data — See Important- 3.

30.5 mm Push Buttons

Specifications

Standard Contact Ratings

Minimum: 24V, 24 mA

Maximum thermal continuous current I_{th} 10 A AC/2.5 A DC. Bulletin 800T units with 800T-XA contacts have ratings as follows:

Max. Operntl. Volts U_e	Utilization Category		Rated Operational Currents		
	IEC	NEMA	Volts U_e	Make	Break
AC 600	AC-15	A600	120...600	7200VA	720VA
			72...120	60 A	720VA
DC 600	DC-13	Q600	24...72	60 A	10 A
			28...600	69VA	2.5 A
			24...28*		

* For applications below 24V/24 mA, PenTUFF or Logic Reed contacts are recommended.

Sealed Switch Contact Ratings

Minimum: 5V, 1 mA

Maximum continuous current I_{th} 5 A. Bulletin 800T units have control circuit ratings with sealed switch contact blocks as follows:

Max. Operntl. Volts U_e	Utilization Category		Rated Operational Currents		
	IEC	NEMA	Volts U_e	Make	Break
AC 600	AC-15	B600	120...600	3600VA	360VA
			0...120	30 A	3 A
DC 300	DC-13	P300	24...300	138VA	5.0 A
			0...24		

Stackable Sealed Switch Contact Ratings

Minimum: 5V, 10 mA (digital); 24V, 1 mA (analog)

Maximum continuous current I_{th} 2.5 A. Bulletin 800T units have control circuit ratings with sealed switch contact blocks as follows:

Max. Operntl. Volts U_e	Utilization Category		Rated Operational Currents		
	IEC	NEMA	Volts U_e	Make	Break
AC 300	AC-15	C300	120...300	1800VA	180VA
			0...120	15 A	1.5 A
DC 150	DC-13	Q150	24...150	69VA	2.5 A
			0...24		

Logic Reed Contact Ratings

Minimum — DC: 5V, 1 mA

Maximum — DC: 30V, 0.06 A, AC: 150V, 0.15 A

Should only be used with resistive loads.

Materials Used in 800H Type 4X Operators

Thermoplastic Polyester (Fiberglass Reinforced)

- Bushings
- Mounting Rings
- Sockets

Thermoplastic Polyester

- Non-illuminated button caps

Transparent Amorphous Nylon

- Pilot light lens cap
- Illuminated button caps

Glass Filled Crystalline Nylon

- Thrust washer

Mineral Filled Nylon

- Trim washer

Nitrile (Synthetic Rubber)

- Gaskets and internal seals

PenTUFF™ (Low Voltage) Contact Ratings

Minimum DC: 5V, 1 mA

Maximum thermal continuous current I_{th} 2.5 A AC/1.0 A DC. Bulletin 800T units with 800T-XAV contacts have ratings as follows:

Max. Operntl. Volts U_e	Utilization Category		Rated Operational Currents		
	IEC	NEMA	Volts U_e	Make	Break
AC 300	AC-15	C300	120...300	1800VA	180VA
			0...120	15 A	1.5 A
DC 150	DC-13	R150	24...150	28VA	1.0 A
			0...24		

Snap Action Contact Ratings

Max. Operntl. Volts U_e	Contact Rating Designation	Rated Operational Currents		
		Volts U_e	Make	Break
AC 300	A300	120...300	7200VA	720VA
		24...72	60 A	10 A
DC 250	—	230...250	0.2 A	
		115...125	0.4 A	

MaxDuty Contact Rating

Maximum thermal continuous current I_{th} 24 A.

Pilot Duty — 120V AC, 12 A; 24V DC, 10 A

Motor Ratings — 120V AC, 1.5 Hp; 240V AC, 3 Hp; 24V DC, 10 A FLA/60 A LRA

Time Delay Contacts





Max. Operntl. Volts U_e	Contact Rating Designation	Rated Operational Currents		
		Volts U_e	Make	Break
AC 120	B150	120	3600VA	360VA

Note: This device is not rated for DC applications.





Adjustment range: 0.5...15 s \pm 25% I_{th} = 5 A

Bulletin 800T/H
30.5 mm Push Buttons
 Specialty Operators

Break-Glass Push Button Stations (Bul. 800T only)
 Complete Station

	Description	Contact Type	Cat. No.
 Cat. No. 800T-NX114	Break-Glass Push Button Station Red push button station in a Type 4/13 enclosure incorporates either one or two snap-action contact blocks, which are operated when the small glass window is broken. Includes STOP legend.	 1 N.O. - 1 N.C.	800T-NX114
		 2 N.O. - 2 N.C. 	800T-NX115

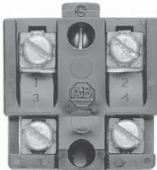
Miscellaneous Kits

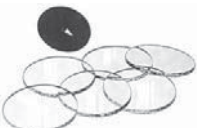
	Description	Contact Type	Cat. No.
 Cat. No. 800T-S6M	Unit Only Kit The break-glass unit less the enclosure is available as a kit to install into the customer's enclosure. The kit includes the contact unit, the hammer and chain and five extra glass discs with one button tack. This kit does not include legend plate. For legend plates, see page 10-48.	 1 N.O. - 1 N.C.  2 N.O. - 2 N.C.	800T-S6M 800T-S6N
 Cat. No. 800T-NXM	Replacement Snap Action Contact Block Kit This kit is used to replace the snap action contact block.	 1 N.O. - 1 N.C.  2 N.O. - 2 N.C.	800T-NXM 800T-NXN
 Cat. No. 800T-N28	Glass Disc Kit Each replacement kit for break-glass push button units or stations consists of six glass discs and one button tack.	Description	Cat. No. 800T-N28

10

Approximate Dimensions

Dimensions in inches (millimeters). Dimensions are not intended to be used for manufacturing purposes.

Break-Glass Station

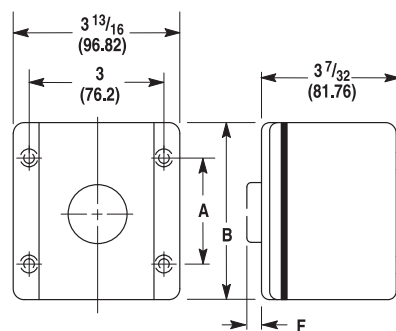

$A = 2 \frac{3}{4}$ (69.85)
 $B = 4 \frac{3}{16}$ (106.38)
 $F = \frac{9}{16}$ (14.28)



SECTION 4

GENERATOR DRAWINGS & INTERCONNECTS



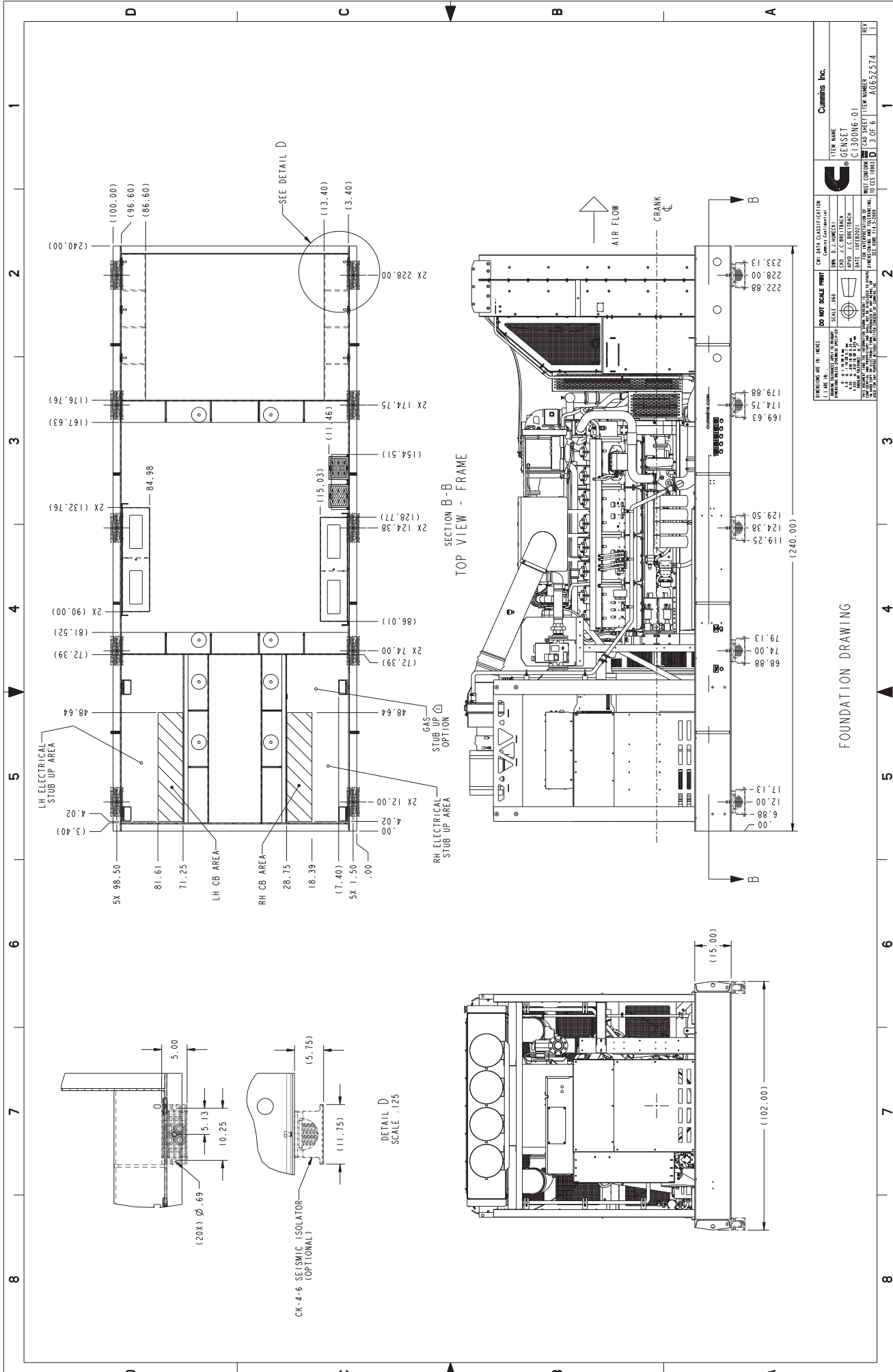

ENGINEERING IN: INCHES		CUMMINS INC.	
DO NOT SCALE PRINT	SCALE: AS SHOWN	TITLE NAME	GENSET
DESIGNED BY: J. C. BREITENBECH	DRAWN BY: J. C. BREITENBECH	CAD SHEET NUMBER	C130006-01
DATE: 08/11/00	DATE: 08/11/00	CAD SHEET ITEM NUMBER	D 3 OF 6
THIS DRAWING IS THE PROPERTY OF CUMMINS INC. IT IS TO BE USED ONLY FOR THE PROJECT AND SITE SPECIFICALLY IDENTIFIED HEREON. IT IS NOT TO BE REPRODUCED, COPIED, OR TRANSMITTED IN ANY FORM OR BY ANY MEANS, ELECTRONIC OR MECHANICAL, WITHOUT THE WRITTEN PERMISSION OF CUMMINS INC.		DATE: 08/11/00	REV: A0652574

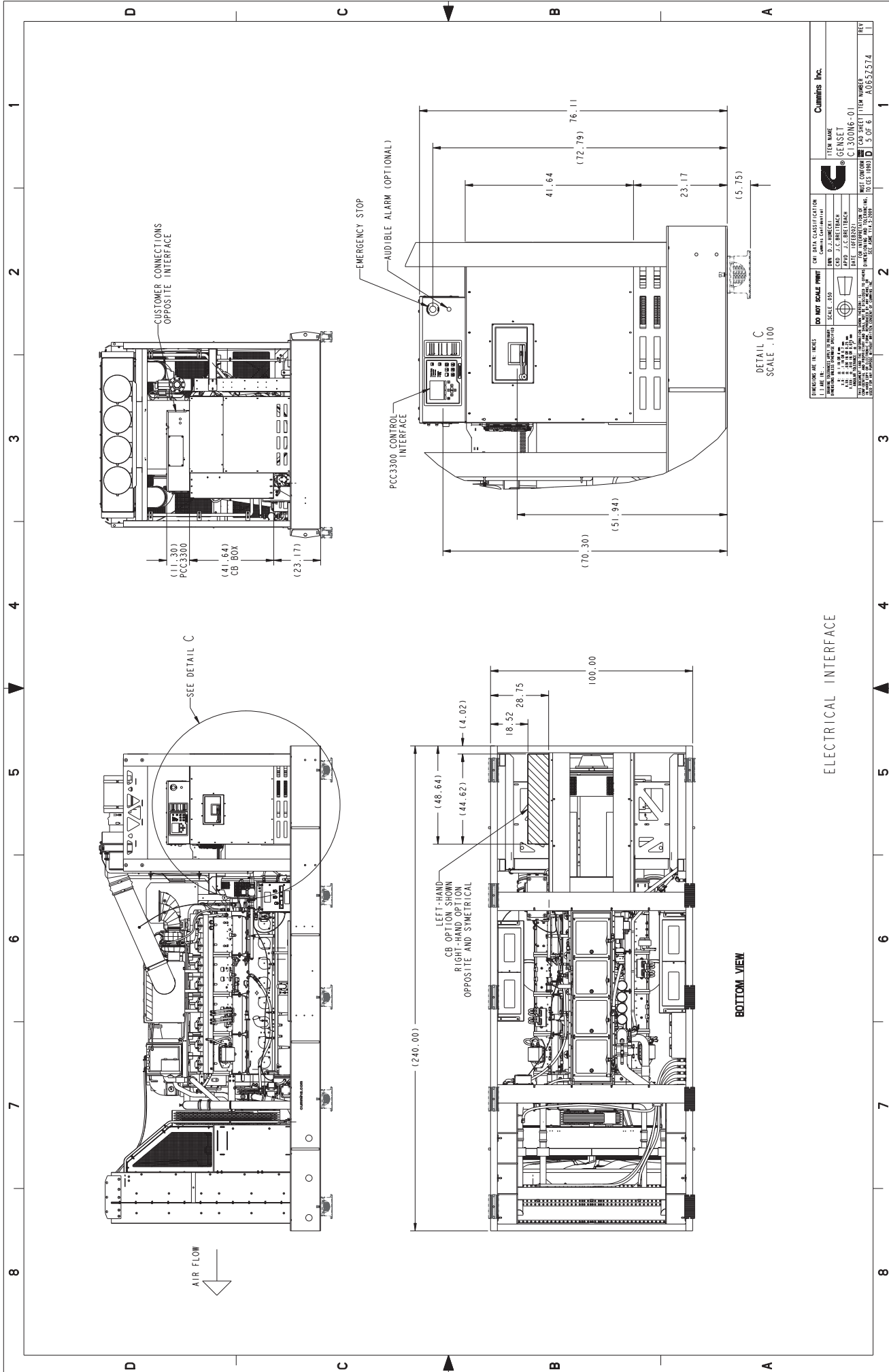

DO NOT SCALE PRINT DIMENSIONS ARE IN INCHES UNLESS OTHERWISE SPECIFIED TOLERANCES: FRACTIONS DECIMALS .0005 .0005 .0005 .0005 .001 .001 .001 .001 .002 .002 .002 .002 .005 .005 .005 .005 .010 .010 .010 .010 .015 .015 .015 .015 .020 .020 .020 .020 .030 .030 .030 .030 .040 .040 .040 .040 .050 .050 .050 .050 .060 .060 .060 .060 .070 .070 .070 .070 .080 .080 .080 .080 .090 .090 .090 .090 .100 .100 .100 .100 .125 .125 .125 .125 .150 .150 .150 .150 .175 .175 .175 .175 .200 .200 .200 .200 .250 .250 .250 .250 .300 .300 .300 .300 .375 .375 .375 .375 .500 .500 .500 .500 .625 .625 .625 .625 .750 .750 .750 .750 .875 .875 .875 .875 1.000 1.000 1.000 1.000 1.250 1.250 1.250 1.250 1.500 1.500 1.500 1.500 1.750 1.750 1.750 1.750 2.000 2.000 2.000 2.000 2.500 2.500 2.500 2.500 3.000 3.000 3.000 3.000 3.750 3.750 3.750 3.750 4.500 4.500 4.500 4.500 5.000 5.000 5.000 5.000 6.000 6.000 6.000 6.000 7.000 7.000 7.000 7.000 8.000 8.000 8.000 8.000 9.000 9.000 9.000 9.000 10.000 10.000 10.000 10.000 12.500 12.500 12.500 12.500 15.000 15.000 15.000 15.000 17.500 17.500 17.500 17.500 20.000 20.000 20.000 20.000 25.000 25.000 25.000 25.000 30.000 30.000 30.000 30.000 37.500 37.500 37.500 37.500 45.000 45.000 45.000 45.000 50.000 50.000 50.000 50.000 60.000 60.000 60.000 60.000 70.000 70.000 70.000 70.000 80.000 80.000 80.000 80.000 90.000 90.000 90.000 90.000 100.000 100.000 100.000 100.000		CUMMINS INC. ITEM NAME GENSET C130006-01 MUST CONFORM TO THE REQUIREMENTS OF THE NATIONAL ELECTRICAL CODE (NEC) AND THE NATIONAL FIRE ALARM AND SIGNAL CODE (NFPA 72). THIS DRAWING IS THE PROPERTY OF CUMMINS INC. IT IS TO BE USED ONLY FOR THE PROJECT AND SITE SPECIFICALLY IDENTIFIED HEREON. IT IS NOT TO BE REPRODUCED, COPIED, OR TRANSMITTED IN ANY FORM OR BY ANY MEANS, ELECTRONIC OR MECHANICAL, INCLUDING PHOTOCOPYING, RECORDING, OR BY ANY INFORMATION STORAGE AND RETRIEVAL SYSTEM, WITHOUT THE WRITTEN PERMISSION OF CUMMINS INC.
DATE: 05/11/06 DRAWN BY: J.C. BREITENBACH CHECKED BY: J.C. BREITENBACH SCALE: 1:1 SHEET NUMBER: 5 OF 6 PROJECT NUMBER: A0652574	CUMMINS INC. ITEM NAME GENSET C130006-01 MUST CONFORM TO THE REQUIREMENTS OF THE NATIONAL ELECTRICAL CODE (NEC) AND THE NATIONAL FIRE ALARM AND SIGNAL CODE (NFPA 72). THIS DRAWING IS THE PROPERTY OF CUMMINS INC. IT IS TO BE USED ONLY FOR THE PROJECT AND SITE SPECIFICALLY IDENTIFIED HEREON. IT IS NOT TO BE REPRODUCED, COPIED, OR TRANSMITTED IN ANY FORM OR BY ANY MEANS, ELECTRONIC OR MECHANICAL, INCLUDING PHOTOCOPYING, RECORDING, OR BY ANY INFORMATION STORAGE AND RETRIEVAL SYSTEM, WITHOUT THE WRITTEN PERMISSION OF CUMMINS INC.	

ELECTRICAL INTERFACE

8 7 6 5 4 3 2 1

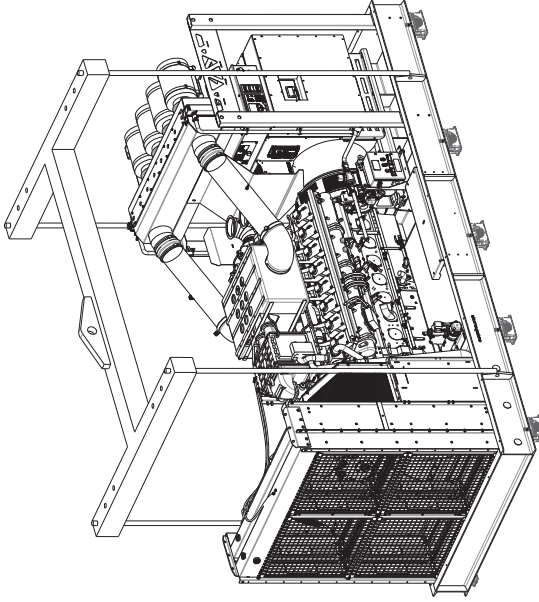

1. IDEAL ARRANGEMENT: LIFTING FRAME AND STRAPS

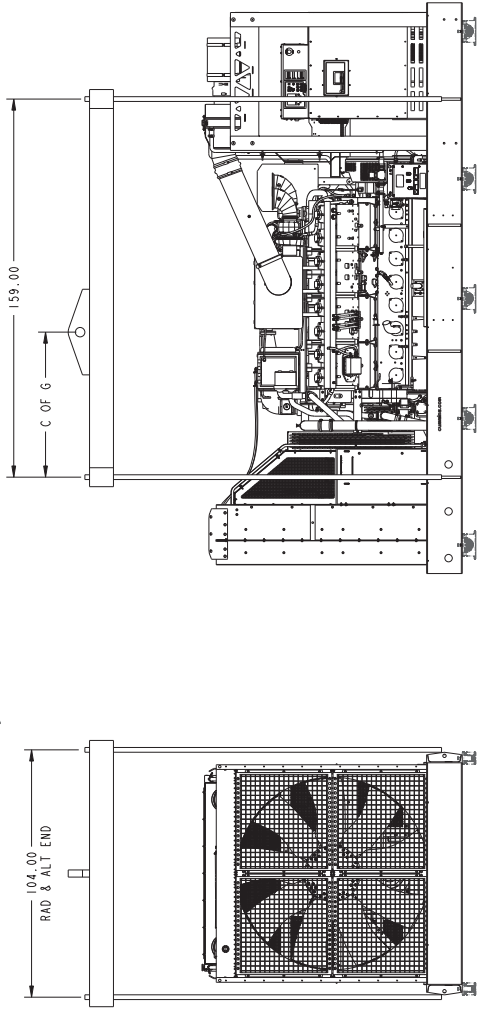

LIFTING ARRANGEMENT FOR GENSET

FOR C OF G VALUE REFER TO SHEET 2

ENGINEERING IN: INCHES	DO NOT SCALE PRINT	REV. DATA CLASSIFICATION	Cummins Inc.
DATE: 11/11/03	SCALE: 1:1	REV. NO. 1	TITLE NAME
DESIGNER: J. C. BREITENBECH	SCALE: 1:1	REV. NO. 2	GENSET
CHECKER: J. C. BREITENBECH	SCALE: 1:1	REV. NO. 3	© C1300G6-01
DATE: 11/11/03	SCALE: 1:1	REV. NO. 4	MUST CONFORM TO C1300G6-01
DATE: 11/11/03	SCALE: 1:1	REV. NO. 5	MUST CONFORM TO C1300G6-01
DATE: 11/11/03	SCALE: 1:1	REV. NO. 6	MUST CONFORM TO C1300G6-01
DATE: 11/11/03	SCALE: 1:1	REV. NO. 7	MUST CONFORM TO C1300G6-01
DATE: 11/11/03	SCALE: 1:1	REV. NO. 8	MUST CONFORM TO C1300G6-01
DATE: 11/11/03	SCALE: 1:1	REV. NO. 9	MUST CONFORM TO C1300G6-01
DATE: 11/11/03	SCALE: 1:1	REV. NO. 10	MUST CONFORM TO C1300G6-01
DATE: 11/11/03	SCALE: 1:1	REV. NO. 11	MUST CONFORM TO C1300G6-01
DATE: 11/11/03	SCALE: 1:1	REV. NO. 12	MUST CONFORM TO C1300G6-01
DATE: 11/11/03	SCALE: 1:1	REV. NO. 13	MUST CONFORM TO C1300G6-01
DATE: 11/11/03	SCALE: 1:1	REV. NO. 14	MUST CONFORM TO C1300G6-01
DATE: 11/11/03	SCALE: 1:1	REV. NO. 15	MUST CONFORM TO C1300G6-01
DATE: 11/11/03	SCALE: 1:1	REV. NO. 16	MUST CONFORM TO C1300G6-01
DATE: 11/11/03	SCALE: 1:1	REV. NO. 17	MUST CONFORM TO C1300G6-01
DATE: 11/11/03	SCALE: 1:1	REV. NO. 18	MUST CONFORM TO C1300G6-01
DATE: 11/11/03	SCALE: 1:1	REV. NO. 19	MUST CONFORM TO C1300G6-01
DATE: 11/11/03	SCALE: 1:1	REV. NO. 20	MUST CONFORM TO C1300G6-01
DATE: 11/11/03	SCALE: 1:1	REV. NO. 21	MUST CONFORM TO C1300G6-01
DATE: 11/11/03	SCALE: 1:1	REV. NO. 22	MUST CONFORM TO C1300G6-01
DATE: 11/11/03	SCALE: 1:1	REV. NO. 23	MUST CONFORM TO C1300G6-01
DATE: 11/11/03	SCALE: 1:1	REV. NO. 24	MUST CONFORM TO C1300G6-01
DATE: 11/11/03	SCALE: 1:1	REV. NO. 25	MUST CONFORM TO C1300G6-01
DATE: 11/11/03	SCALE: 1:1	REV. NO. 26	MUST CONFORM TO C1300G6-01
DATE: 11/11/03	SCALE: 1:1	REV. NO. 27	MUST CONFORM TO C1300G6-01
DATE: 11/11/03	SCALE: 1:1	REV. NO. 28	MUST CONFORM TO C1300G6-01
DATE: 11/11/03	SCALE: 1:1	REV. NO. 29	MUST CONFORM TO C1300G6-01
DATE: 11/11/03	SCALE: 1:1	REV. NO. 30	MUST CONFORM TO C1300G6-01
DATE: 11/11/03	SCALE: 1:1	REV. NO. 31	MUST CONFORM TO C1300G6-01
DATE: 11/11/03	SCALE: 1:1	REV. NO. 32	MUST CONFORM TO C1300G6-01
DATE: 11/11/03	SCALE: 1:1	REV. NO. 33	MUST CONFORM TO C1300G6-01
DATE: 11/11/03	SCALE: 1:1	REV. NO. 34	MUST CONFORM TO C1300G6-01
DATE: 11/11/03	SCALE: 1:1	REV. NO. 35	MUST CONFORM TO C1300G6-01
DATE: 11/11/03	SCALE: 1:1	REV. NO. 36	MUST CONFORM TO C1300G6-01
DATE: 11/11/03	SCALE: 1:1	REV. NO. 37	MUST CONFORM TO C1300G6-01
DATE: 11/11/03	SCALE: 1:1	REV. NO. 38	MUST CONFORM TO C1300G6-01
DATE: 11/11/03	SCALE: 1:1	REV. NO. 39	MUST CONFORM TO C1300G6-01
DATE: 11/11/03	SCALE: 1:1	REV. NO. 40	MUST CONFORM TO C1300G6-01
DATE: 11/11/03	SCALE: 1:1	REV. NO. 41	MUST CONFORM TO C1300G6-01
DATE: 11/11/03	SCALE: 1:1	REV. NO. 42	MUST CONFORM TO C1300G6-01
DATE: 11/11/03	SCALE: 1:1	REV. NO. 43	MUST CONFORM TO C1300G6-01
DATE: 11/11/03	SCALE: 1:1	REV. NO. 44	MUST CONFORM TO C1300G6-01
DATE: 11/11/03	SCALE: 1:1	REV. NO. 45	MUST CONFORM TO C1300G6-01
DATE: 11/11/03	SCALE: 1:1	REV. NO. 46	MUST CONFORM TO C1300G6-01
DATE: 11/11/03	SCALE: 1:1	REV. NO. 47	MUST CONFORM TO C1300G6-01
DATE: 11/11/03	SCALE: 1:1	REV. NO. 48	MUST CONFORM TO C1300G6-01
DATE: 11/11/03	SCALE: 1:1	REV. NO. 49	MUST CONFORM TO C1300G6-01
DATE: 11/11/03	SCALE: 1:1	REV. NO. 50	MUST CONFORM TO C1300G6-01

8 7 6 5 4 3 2 1

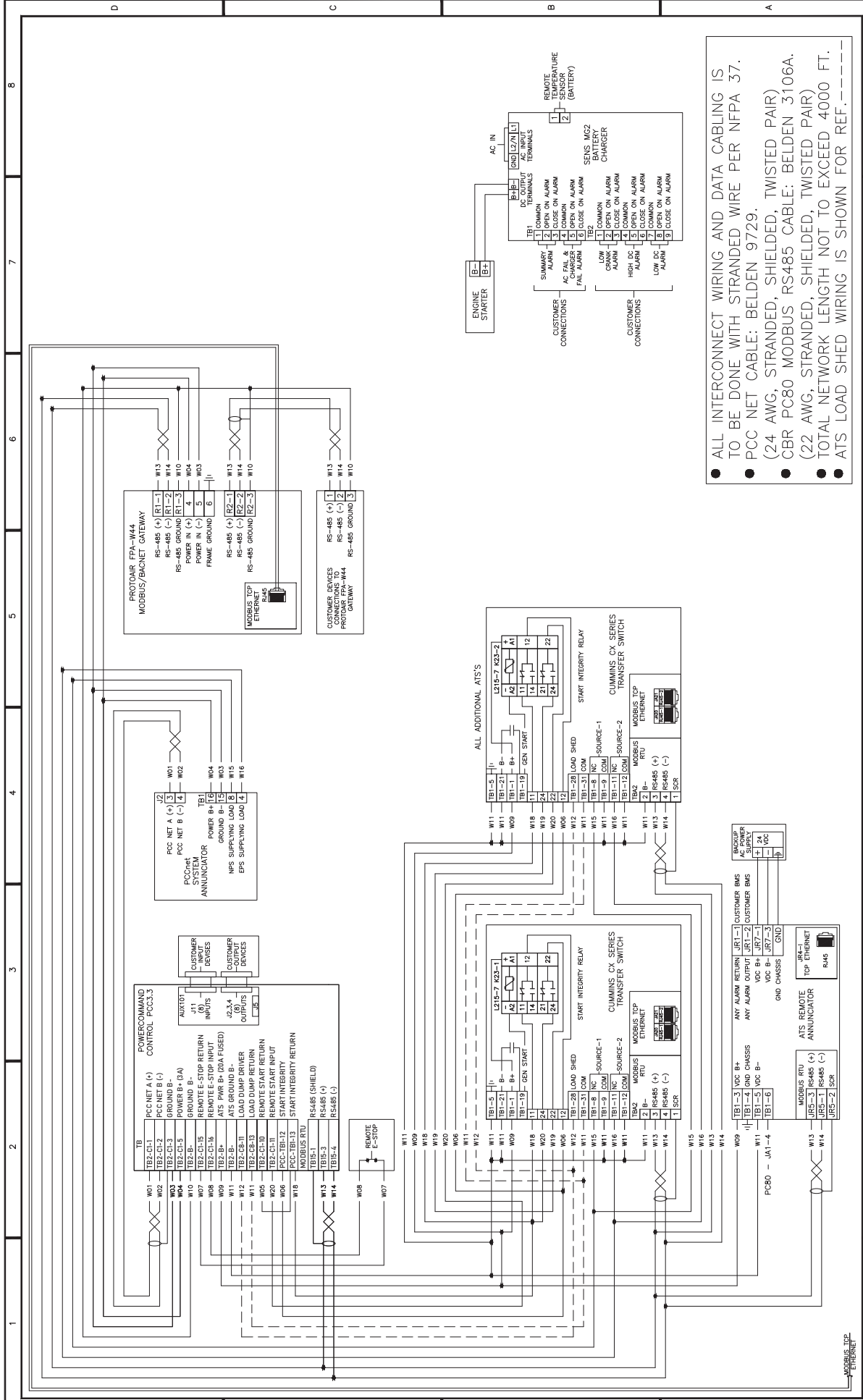

- ALL INTERCONNECT WIRING AND DATA CABLING IS TO BE DONE WITH STRANDED WIRE PER NFPA 37.
- PCC NET CABLE: BELDEN 9729.
- (24 AWG, STRANDED, SHIELDED, TWISTED PAIR)
- (22 AWG, STRANDED, SHIELDED, TWISTED PAIR)
- TOTAL NETWORK LENGTH NOT TO EXCEED 4000 FT.
- ATS LOAD SHED WIRING IS SHOWN FOR REF.---

UNLESS OTHERWISE SPECIFIED, ALL DIMENSIONS ARE IN INCHES 	TOLERANCES: FRACTIONAL: .X: .06 .XX: .03 .XXX: .01 ANGLES: .5°	REFERENCES A067G824 0630-3440 A060M201	PREP. BY: KDU 10/01/24 CHKD BY: - MODIFIED BY: - FINISH: N/A	ENGINE FAMILY: PCC3300 CBR SERIES ATS
	TITLE: PCC3.3 CONTROL / CBR SERIES ATS SIZE: B DWG NO: QSK600 - C10000B / C13000G SCALE: NONE PCC3.3 INTERCONNECT SHEET 1 OF 1			



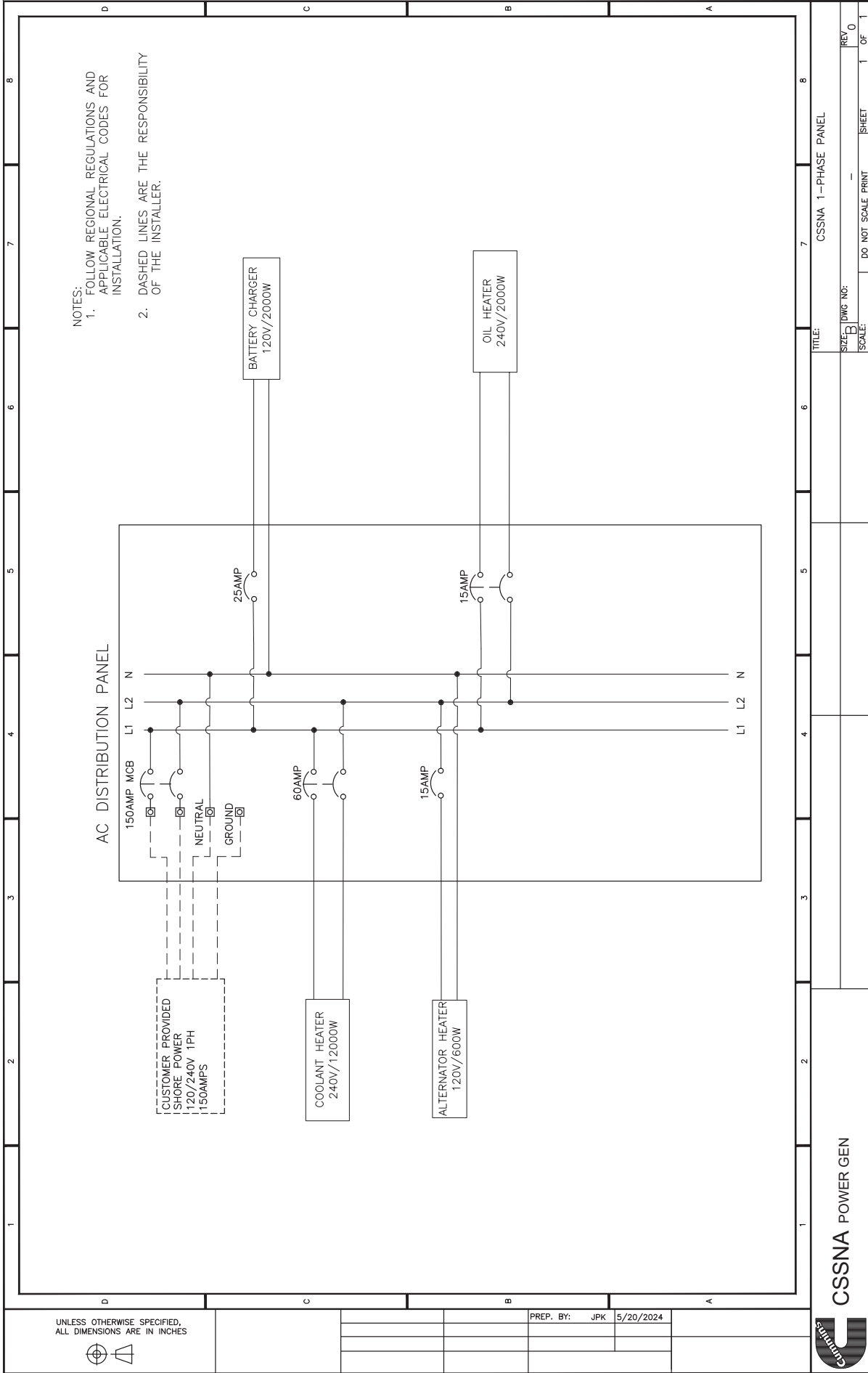

- NOTES:
1. FOLLOW REGIONAL REGULATIONS AND APPLICABLE ELECTRICAL CODES FOR INSTALLATION.
 2. DASHED LINES ARE THE RESPONSIBILITY OF THE INSTALLER.

UNLESS OTHERWISE SPECIFIED, ALL DIMENSIONS ARE IN INCHES



PREP. BY: JPK 5/20/2024



CSSNA POWER GEN

TITLE: CSSNA 1-PHASE PANEL

SIZE: DWG NO: -

SCALE: DO NOT SCALE PRINT

SHEET 1 OF 1

REV 0

REV	REL NO	REVISION	OWN	CD	APYD	DATE
0		2020-290 INITIAL RELEASE	D.JH	JCB	JCB	17JUL20
2		2021-116 ADDED (2X) 0155-4589 V-BAND CLAMPS	D.JH	JCB	JCB	28APR21
3		2022-014 UPDATED PER A064X217	JRC	JCB	JCB	20JAN22

ITEM/QT	DESCRIPTION	PART NUMBER
1	2 RAIN CAP. 8". GT EXHAUST 22-800	22-800
2	2 CLAMP - EXHAUST- VEE BAND 250 ID	0155-4092
3	4 KIT GASKET, W/1. BOLT- FULL FACE FIBER 8	23580-8000
4	1 TUBE EXHAUST TRANSFER: LH. FLEX ELBOW. 60L	A064X215
5	1 TUBE EXHAUST TRANSFER: RH. FLEX ELBOW. 60L	A064X216
6	2 MUFFLER. 60L. CRITICAL EXHAUST	A064X217
7	2 TUBE EXHAUST TRANSFER: EXTENSION. 60L CRITICAL	A064X218
8	1 BLANKET EXH CONNECTION: OS160	A065P229

8 BILL OF MATERIAL

1 2 3 4 5 6 7 8

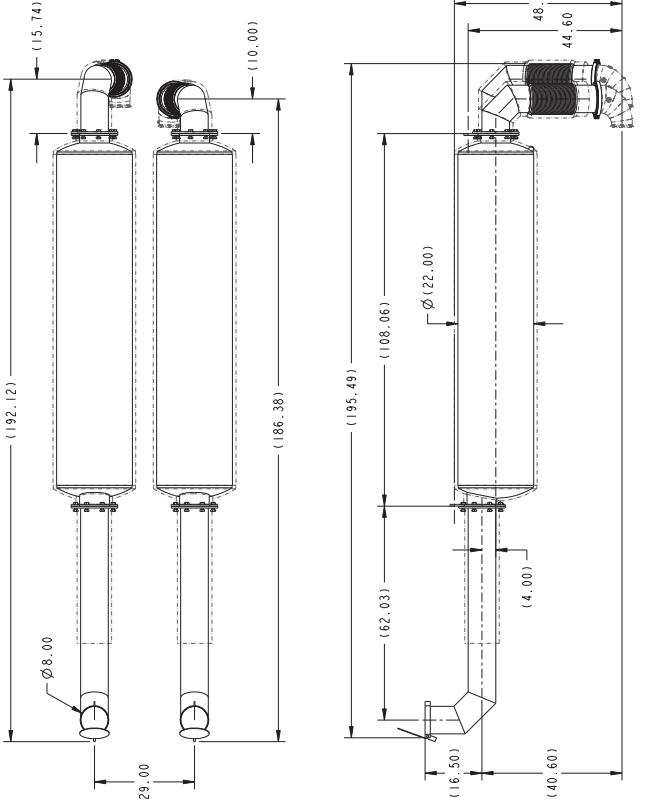
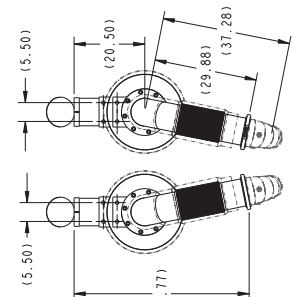
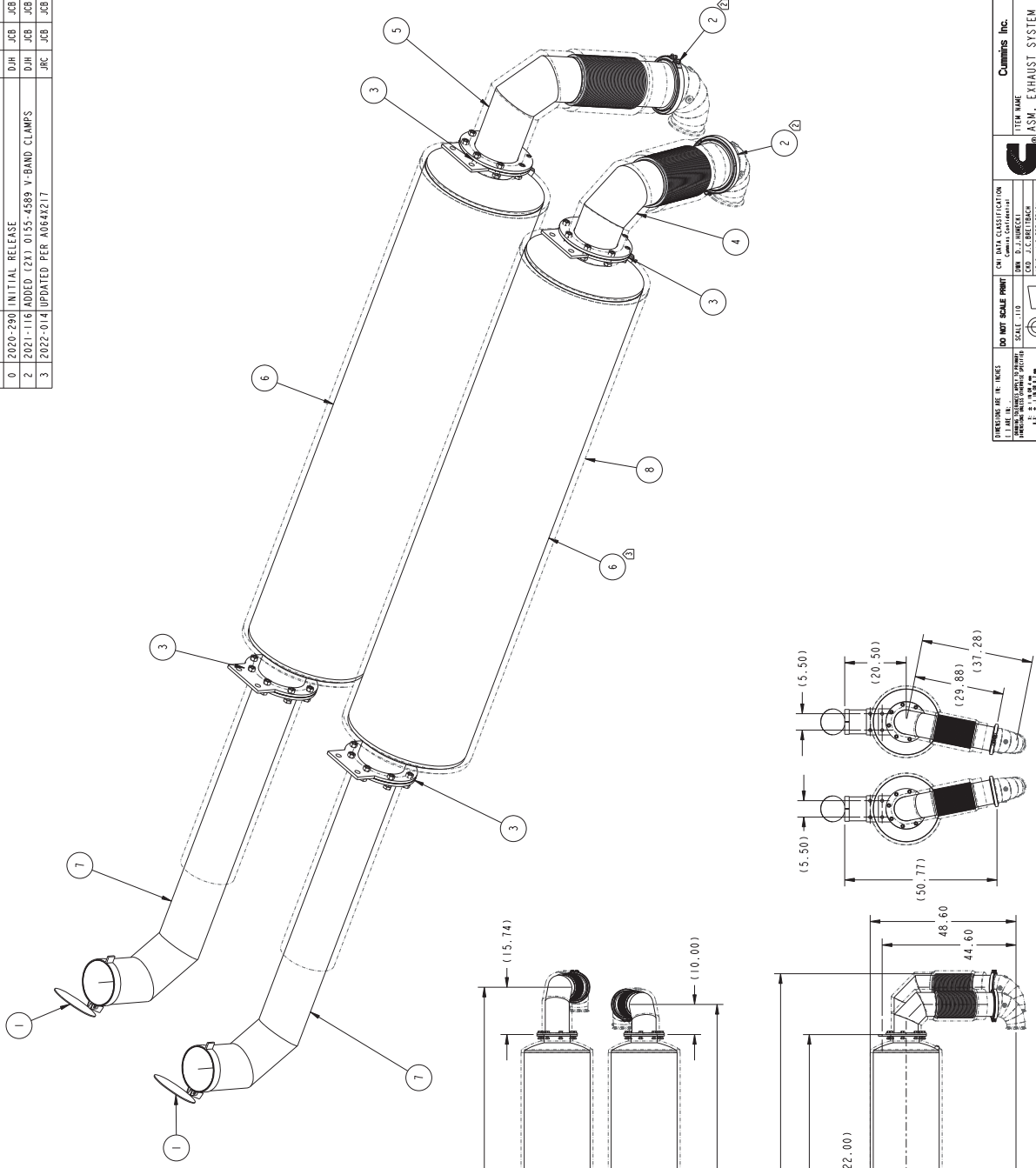

A B C D

DO NOT SCALE PRINT		CUMMINS INC.	
ITEM NAME	ASM. EXHAUST SYSTEM	ITEM NUMBER	A064X214
ITEM NUMBER	60L. CRITICAL	ITEM NAME	ASM. EXHAUST SYSTEM
ITEM NAME	60L. CRITICAL	ITEM NUMBER	A064X214
ITEM NUMBER	A064X214	ITEM NAME	ASM. EXHAUST SYSTEM
ITEM NAME	ASM. EXHAUST SYSTEM	ITEM NUMBER	A064X214
ITEM NUMBER	A064X214	ITEM NAME	ASM. EXHAUST SYSTEM

1 2 3 4 5 6 7 8

REV	REL NO	REVISION	DWN	CHD	APYD	DATE
0	2020-283	INITIAL RELEASE	D.JH	_JCB	_JCB	17JUL20
1	2022-014	ADDED LIFT TABS TO BOTH FLANGES	JRC	_JCB	_JCB	20JAN22

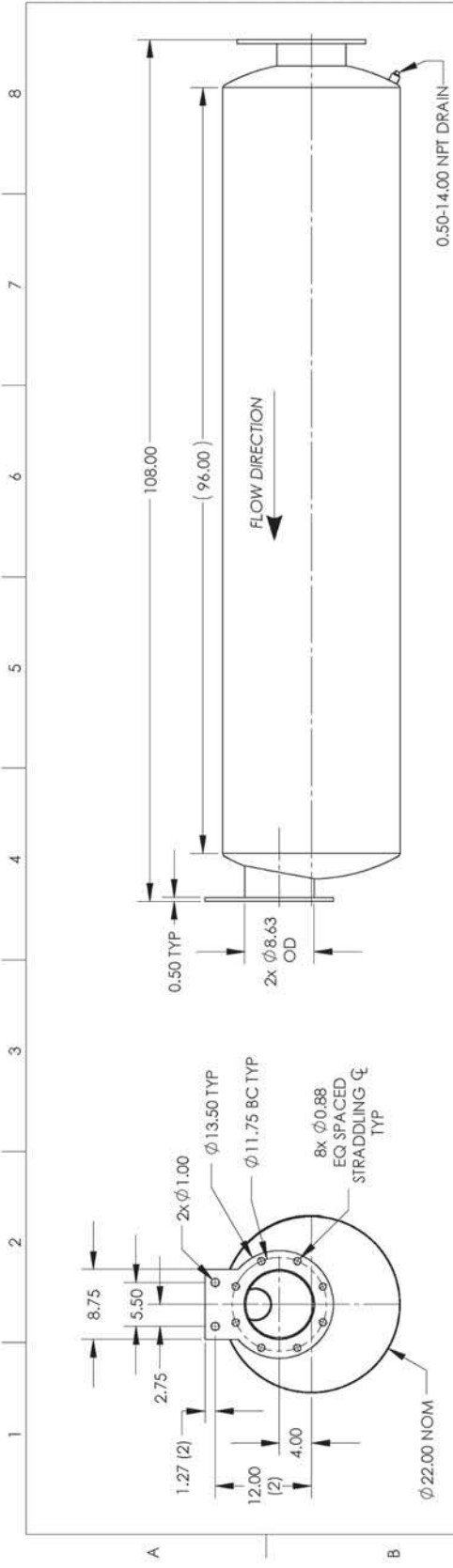

DESIGNED FOR DUAL SILENCERS IN PARALLEL

ENGINE INFORMATION		SILENCER INFORMATION		DRAWN BY		DATE	
ENGINE MAKE	CUMMINS	REGONATOR FREQUENCY	---	ENGINEER	HKO	DATE	06/17/2021
DISPLACEMENT	6.7L/407 CC	REGONATOR ALPHA	---	ENGINEER	HKO	DATE	06/17/2021
EXHAUST FLOW	367.188	SILENCER VOL	---	MANUFACTURING	HKO	DATE	06/17/2021
EXHAUST TEMPERATURE	594.1700	SILENCER	---	TOLERANCES UNLESS SPECIFIED	CS	CONSTRUCTION MATERIAL	---
		SILENCER EXHAUST PORT TO EXHAUST MANIFOLD	---	A = 0.005	AL ALUMINUM	CS	---
		MAX BACK PRESSURE	---	B = 0.010	STEEL	CS	---
		MAX SOUND PRESSURE	---	C = 0.020	STAINLESS STEEL	CS	---
		DESCRIPTION	ADJUSTED FLANGE DIMENSIONS	PART NUMBER			
				500-0147-63			
				FINISH: HIGH TEMP BLACK PAINT			
				SHEET 3 OF 3			
				SCALE: 1:1			
				SHEET SIZE: B			

REV.	BY	DATE	DESCRIPTION
02	HKO	01/20/2022	ADJUSTED FLANGE DIMENSIONS

- NOTES:
- VENDOR: BERGARI
 - DESC: SILENCER, CRITICAL GRADE
 - VENDOR PN: 500-014763 REV 02
 - FINISH: HIGH TEMP BLACK PAINT

ENGINEER		DATE	
ENGINEER	HKO	DATE	06/17/2021
CHECKED	HKO	DATE	06/17/2021
APPROVED	HKO	DATE	06/17/2021

CUSTOMER		DATE	
CUSTOMER	---	DATE	---

ENGINEER		DATE	
ENGINEER	HKO	DATE	06/17/2021
CHECKED	HKO	DATE	06/17/2021
APPROVED	HKO	DATE	06/17/2021

CUSTOMER		DATE	
CUSTOMER	---	DATE	---

ENGINEER		DATE	
ENGINEER	HKO	DATE	06/17/2021
CHECKED	HKO	DATE	06/17/2021
APPROVED	HKO	DATE	06/17/2021

CUSTOMER		DATE	
CUSTOMER	---	DATE	---

ENGINEER		DATE	
ENGINEER	HKO	DATE	06/17/2021
CHECKED	HKO	DATE	06/17/2021
APPROVED	HKO	DATE	06/17/2021

CUSTOMER		DATE	
CUSTOMER	---	DATE	---

ENGINEER		DATE	
ENGINEER	HKO	DATE	06/17/2021
CHECKED	HKO	DATE	06/17/2021
APPROVED	HKO	DATE	06/17/2021

CUSTOMER		DATE	
CUSTOMER	---	DATE	---

ENGINEER		DATE	
ENGINEER	HKO	DATE	06/17/2021
CHECKED	HKO	DATE	06/17/2021
APPROVED	HKO	DATE	06/17/2021

CUSTOMER		DATE	
CUSTOMER	---	DATE	---

ENGINEER		DATE	
ENGINEER	HKO	DATE	06/17/2021
CHECKED	HKO	DATE	06/17/2021
APPROVED	HKO	DATE	06/17/2021

CUSTOMER		DATE	
CUSTOMER	---	DATE	---

ENGINEER		DATE	
ENGINEER	HKO	DATE	06/17/2021
CHECKED	HKO	DATE	06/17/2021
APPROVED	HKO	DATE	06/17/2021

CUSTOMER		DATE	
CUSTOMER	---	DATE	---

ENGINEER		DATE	
ENGINEER	HKO	DATE	06/17/2021
CHECKED	HKO	DATE	06/17/2021
APPROVED	HKO	DATE	06/17/2021

CUSTOMER		DATE	
CUSTOMER	---	DATE	---

ENGINEER		DATE	
ENGINEER	HKO	DATE	06/17/2021
CHECKED	HKO	DATE	06/17/2021
APPROVED	HKO	DATE	06/17/2021

CUSTOMER		DATE	
CUSTOMER	---	DATE	---

ENGINEER		DATE	
ENGINEER	HKO	DATE	06/17/2021
CHECKED	HKO	DATE	06/17/2021
APPROVED	HKO	DATE	06/17/2021

CUSTOMER		DATE	
CUSTOMER	---	DATE	---

ENGINEER		DATE	
ENGINEER	HKO	DATE	06/17/2021
CHECKED	HKO	DATE	06/17/2021
APPROVED	HKO	DATE	06/17/2021

CUSTOMER		DATE	
CUSTOMER	---	DATE	---

ENGINEER		DATE	
ENGINEER	HKO	DATE	06/17/2021
CHECKED	HKO	DATE	06/17/2021
APPROVED	HKO	DATE	06/17/2021

CUSTOMER		DATE	
CUSTOMER	---	DATE	---

ENGINEER		DATE	
ENGINEER	HKO	DATE	06/17/2021
CHECKED	HKO	DATE	06/17/2021
APPROVED	HKO	DATE	06/17/2021

CUSTOMER		DATE	
CUSTOMER	---	DATE	---

ENGINEER		DATE	
ENGINEER	HKO	DATE	06/17/2021
CHECKED	HKO	DATE	06/17/2021
APPROVED	HKO	DATE	06/17/2021

CUSTOMER		DATE	
CUSTOMER	---	DATE	---

ENGINEER		DATE	
ENGINEER	HKO	DATE	06/17/2021
CHECKED	HKO	DATE	06/17/2021
APPROVED	HKO	DATE	06/17/2021

CUSTOMER		DATE	
CUSTOMER	---	DATE	---

ENGINEER		DATE	
ENGINEER	HKO	DATE	06/17/2021
CHECKED	HKO	DATE	06/17/2021
APPROVED	HKO	DATE	06/17/2021

CUSTOMER		DATE	
CUSTOMER	---	DATE	---

ENGINEER		DATE	
ENGINEER	HKO	DATE	06/17/2021
CHECKED	HKO	DATE	06/17/2021
APPROVED	HKO	DATE	06/17/2021

CUSTOMER		DATE	
CUSTOMER	---	DATE	---

ENGINEER		DATE	
ENGINEER	HKO	DATE	06/17/2021
CHECKED	HKO	DATE	06/17/2021
APPROVED	HKO	DATE	06/17/2021

CUSTOMER		DATE	
CUSTOMER	---	DATE	---

ENGINEER		DATE	
ENGINEER	HKO	DATE	06/17/2021
CHECKED	HKO	DATE	06/17/2021
APPROVED	HKO	DATE	06/17/2021

CUSTOMER		DATE	
CUSTOMER	---	DATE	---

ENGINEER		DATE	
ENGINEER	HKO	DATE	06/17/2021
CHECKED	HKO	DATE	06/17/2021
APPROVED	HKO	DATE	06/17/2021

CUSTOMER		DATE	
CUSTOMER	---	DATE	---

ENGINEER		DATE	
ENGINEER	HKO	DATE	06/17/2021
CHECKED	HKO	DATE	06/17/2021
APPROVED	HKO	DATE	06/17/2021

CUSTOMER		DATE	
CUSTOMER	---	DATE	---

ENGINEER		DATE	
ENGINEER	HKO	DATE	06/17/2021
CHECKED	HKO	DATE	06/17/2021
APPROVED	HKO	DATE	06/17/2021

CUSTOMER		DATE	
CUSTOMER	---	DATE	---

ENGINEER		DATE	
ENGINEER	HKO	DATE	06/17/2021
CHECKED	HKO	DATE	06/17/2021
APPROVED	HKO	DATE	06/17/2021

CUSTOMER		DATE	
CUSTOMER	---	DATE	---

ENGINEER		DATE	
ENGINEER	HKO	DATE	06/17/2021
CHECKED	HKO	DATE	06/17/2021
APPROVED	HKO	DATE	06/17/2021

CUSTOMER		DATE	
CUSTOMER	---	DATE	---

ENGINEER		DATE	
ENGINEER	HKO	DATE	06/17/2021
CHECKED	HKO	DATE	06/17/2021
APPROVED	HKO	DATE	06/17/2021

CUSTOMER		DATE	
CUSTOMER	---	DATE	---

ENGINEER		DATE	
ENGINEER	HKO	DATE	06/17/2021
CHECKED	HKO	DATE	06/17/2021
APPROVED	HKO	DATE	06/17/2021

CUSTOMER		DATE	
CUSTOMER	---	DATE	---

ENGINEER		DATE	
ENGINEER	HKO	DATE	06/17/2021
CHECKED	HKO	DATE	06/17/2021
APPROVED	HKO	DATE	06/17/2021

CUSTOMER		DATE	
CUSTOMER	---	DATE	---

ENGINEER		DATE	
ENGINEER	HKO	DATE	06/17/2021
CHECKED	HKO	DATE	06/17/2021
APPROVED	HKO	DATE	06/17/2021

CUSTOMER		DATE	
CUSTOMER	---	DATE	---

ENGINEER		DATE	
ENGINEER	HKO	DATE	06/17/2021
CHECKED	HKO	DATE	06/17/2021
APPROVED	HKO	DATE	06/17/2021

CUSTOMER		DATE	
CUSTOMER	---	DATE	---

ENGINEER		DATE	
ENGINEER	HKO	DATE	06/17/2021
CHECKED	HKO	DATE	06/17/2021
APPROVED	HKO	DATE	06/17/2021

CUSTOMER		DATE	
CUSTOMER	---	DATE	---

ENGINEER		DATE	
ENGINEER	HKO	DATE	06/17/2021
CHECKED	HKO	DATE	06/17/2021
APPROVED			

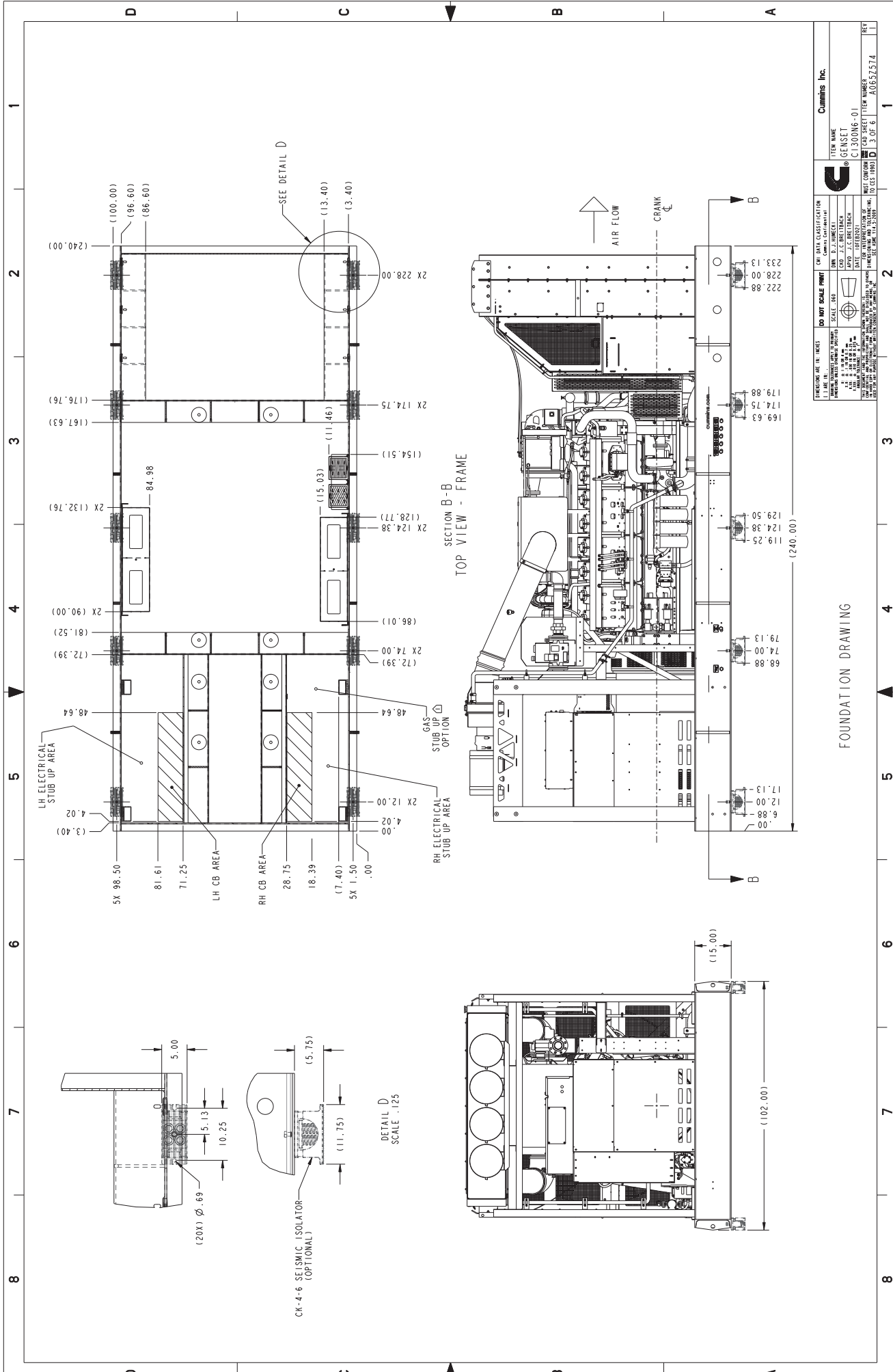

DIMENSIONS ARE IN INCHES		CUMMINS INC.	
DO NOT SCALE PRINT		TITER NAME	
ENGINE MODEL NUMBER	SCALE: AS SHOWN	GENSET	
ENGINE SERIAL NUMBER	DATE: 11/14/06	© C1300N6-01	
DESIGNER: J.C. BREITENBECH	DATE: 11/14/06	MUST CONFORM TO THE LATEST REVISIONS OF THE CUMMINS SPECIFICATIONS AND DRAWINGS.	
CHECKER: J.C. BREITENBECH	DATE: 11/14/06	CUMMINS INC. CAD SHEET ITEM NUMBER	
DATE: 11/14/06	DATE: 11/14/06	D 3 OF 6	
DATE: 11/14/06	DATE: 11/14/06	A0652574	
DATE: 11/14/06	DATE: 11/14/06	REV	

REV	REL NO	REVISION	DATE
0	2022-123	INITIAL RELEASE	12/31/2022

SHEET #	LEGEND
1	ISOMETRIC VIEWS, GENSET FEATURE IDENTIFICATION
2	GENSET/ALTERNATOR MODELS
3	WEIGHTS, CENTER OF GRAVITY
4	GENERAL DIMENSIONS
5	FOUNDATION DRAWING
6	GAS/FUEL CONNECTION
7	EXHAUST CONNECTION
8	ELECTRICAL INTERFACE
9	LIFTING DIAGRAM

- NOTES:**
- DIMENSIONS:
 - ALL DIMENSIONS ARE IN INCHES
 - ALL DIMENSIONS ARE REFERENCE UNLESS SPECIFICALLY TOLERANCED
 - WEIGHT: REFER TO TABLE(S) ON SHEET 2 FOR STANDARD GENSET NET AND DRY WEIGHT(S)
 - LARGEST NOMINAL DIMENSIONS:
 - LENGTH: 402.7 INCHES
 - WIDTH: 102.0 INCHES
 - HEIGHT: 130.5 INCHES
 - DOES NOT INCLUDE THE HEIGHT OF THE ISOLATORS
 - LIFTING INSTRUCTIONS: REFER TO GENSET INSTALLATION MANUAL AND LIFTING LABEL

NOTE: GENSET SHALL NOT BE LIFTED USING THE LIFTING EYES MOUNTED TO THE ENCLOSURE. LIFTING EYES ARE TO BE USED ONLY FOR REMOVING OR INSTALLING ENCLOSURE.

NOTE: GENSET SHALL NOT BE LIFTED USING THE LIFTING EYES MOUNTED TO THE RADIATOR. RADIATOR LIFTING EYES ARE TO BE USED ONLY FOR REMOVING OR INSTALLING RADIATOR.
 - ALLOW 6.5 FEET AROUND THE GENSET FOR SERVICE
 - ELECTRICAL SPECIFIC NOTES ON SHEET 5

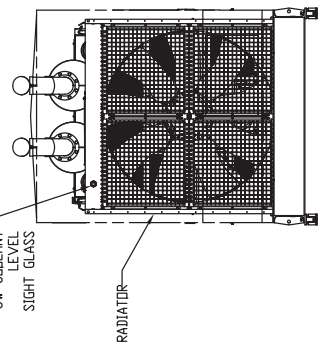

FRONT VIEW

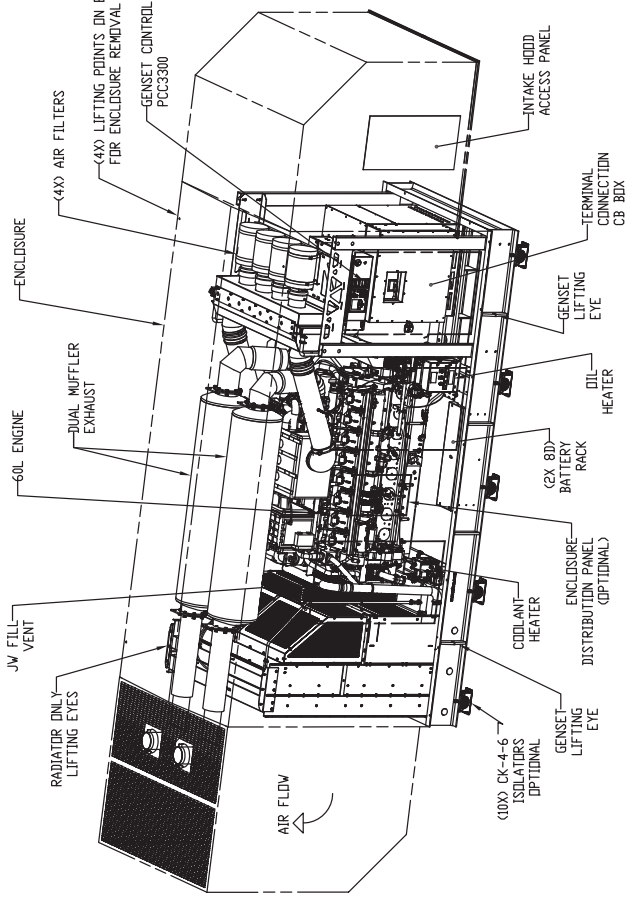

LEFT SIDE

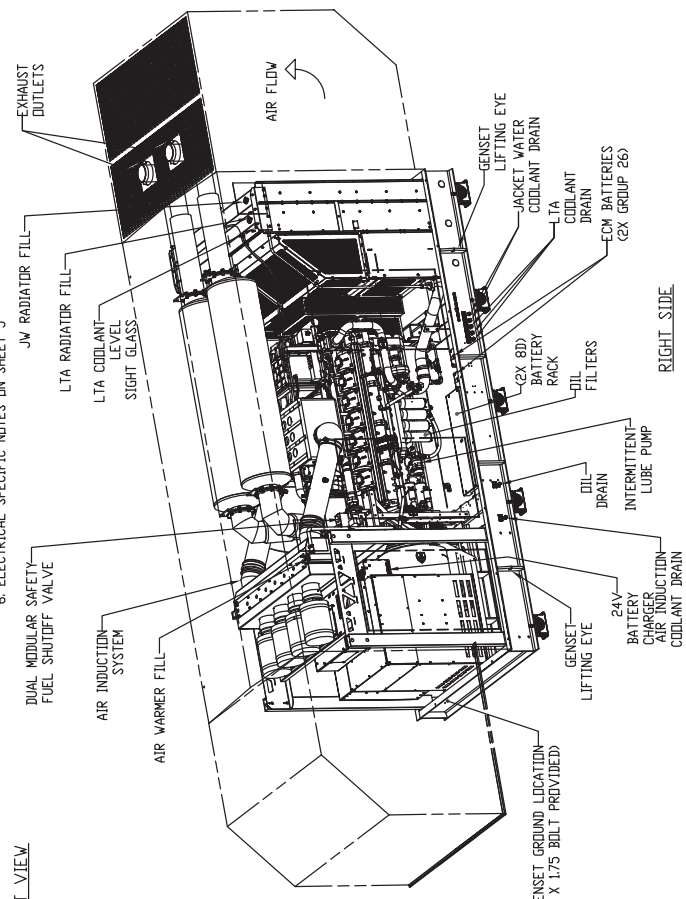

RIGHT SIDE

REV	REL NO	REVISION	DATE
0	2022-123	INITIAL RELEASE	12/31/2022

REV	REL NO	REVISION	DATE
0	2022-123	INITIAL RELEASE	12/31/2022

REV	REL NO	REVISION	DATE
0	2022-123	INITIAL RELEASE	12/31/2022

DIMENSIONS ARE IN INCHES
 1/8" = 1" UNLESS OTHERWISE SPECIFIED
 SCALE: AS SHOWN
 DRAWING NUMBER: 1300068-B-03
 SHEET NUMBER: 03 OF 06
 PROJECT NUMBER: 1300068-B-03
 DATE: 12/31/2022
 DRAWN BY: J. J. BRETHERTON
 CHECKED BY: J. J. BRETHERTON
 APPROVED BY: J. J. BRETHERTON
 CUMMINS INC.

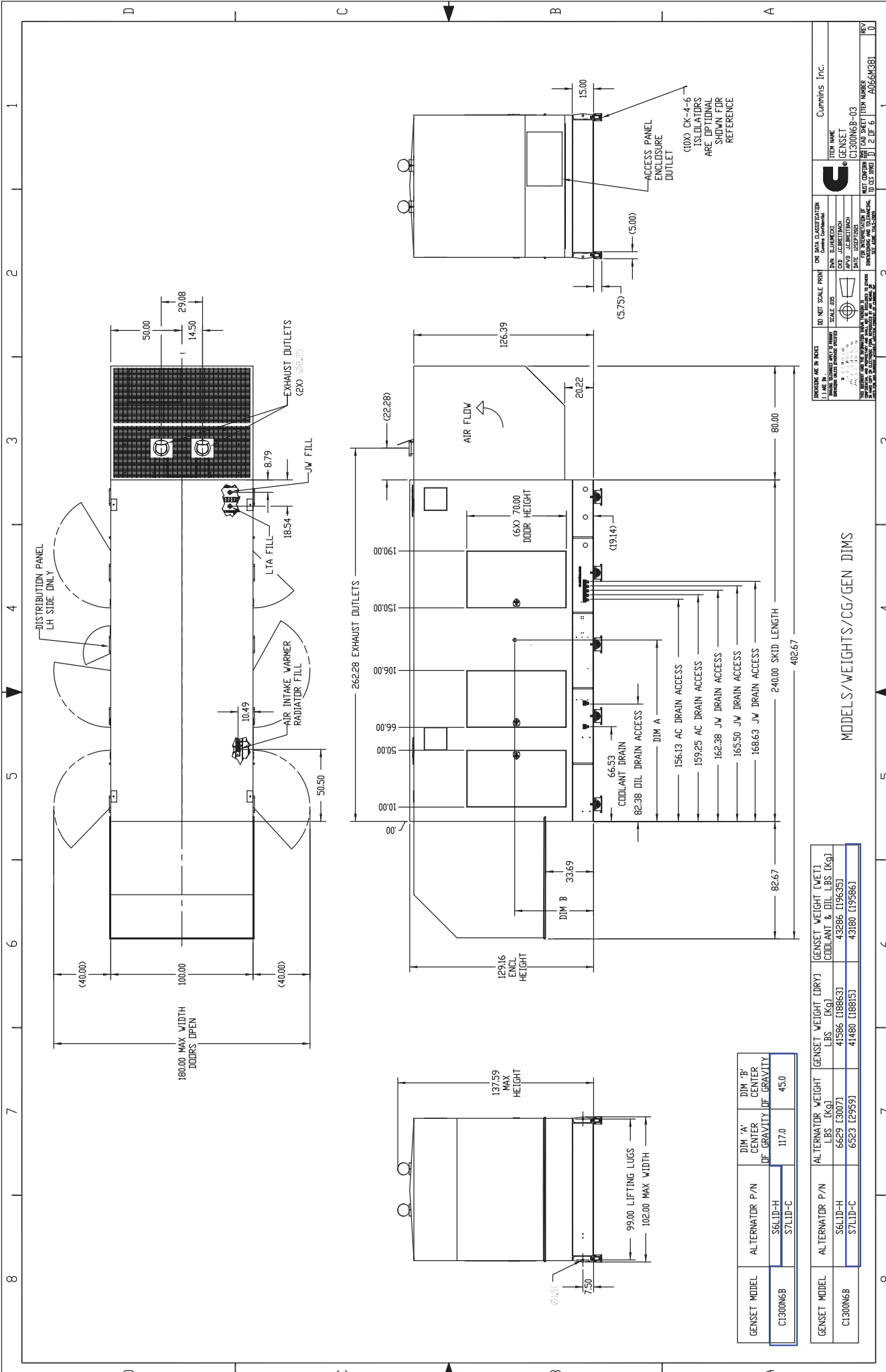

MODELS/WEIGHTS/CG/GEN DIMS

GENSET MODEL	ALTERNATOR P/N	DIM 'A' CENTER OF GRAVITY	DIM 'B' CENTER OF GRAVITY
C1300N6B	S6LID-H	117.0	45.0
	S7LID-C		

GENSET MODEL	ALTERNATOR P/N	GENSET WEIGHT (DRY) LBS [KG]	GENSET WEIGHT (WET) LBS [KG]	COOLANT & DIL. LBS [KG]
C1300N6B	S6LID-H	6629 [3007]	41586 [18863]	43286 [19635]
	S7LID-C	6523 [2959]	41480 [18815]	43180 [19586]

PROVISIONS ARE IN INCHES UNLESS OTHERWISE SPECIFIED	DO NOT SCALE PRINT	ON DATA CLASSIFICATION	TECH NAME
SCALE: AS SHOWN <td></td> <td>DATE: 01/23/2013 <td>CUMMINS, Inc.</td> </td>		DATE: 01/23/2013 <td>CUMMINS, Inc.</td>	CUMMINS, Inc.
DATE: 01/23/2013		BY: J. J. BUCHHEIT	
DATE: 01/23/2013		CHK: J. J. BUCHHEIT	
DATE: 01/23/2013		APP: J. J. BUCHHEIT	
DATE: 01/23/2013		DES: J. J. BUCHHEIT	
DATE: 01/23/2013		DRW: J. J. BUCHHEIT	
DATE: 01/23/2013		REV: J. J. BUCHHEIT	

GENSET MODEL	ALTERNATOR P/N	DIM 'A' CENTER OF GRAVITY	DIM 'B' CENTER OF GRAVITY
C1300N6B	S6LID-H	117.0	45.0
	S7LID-C		

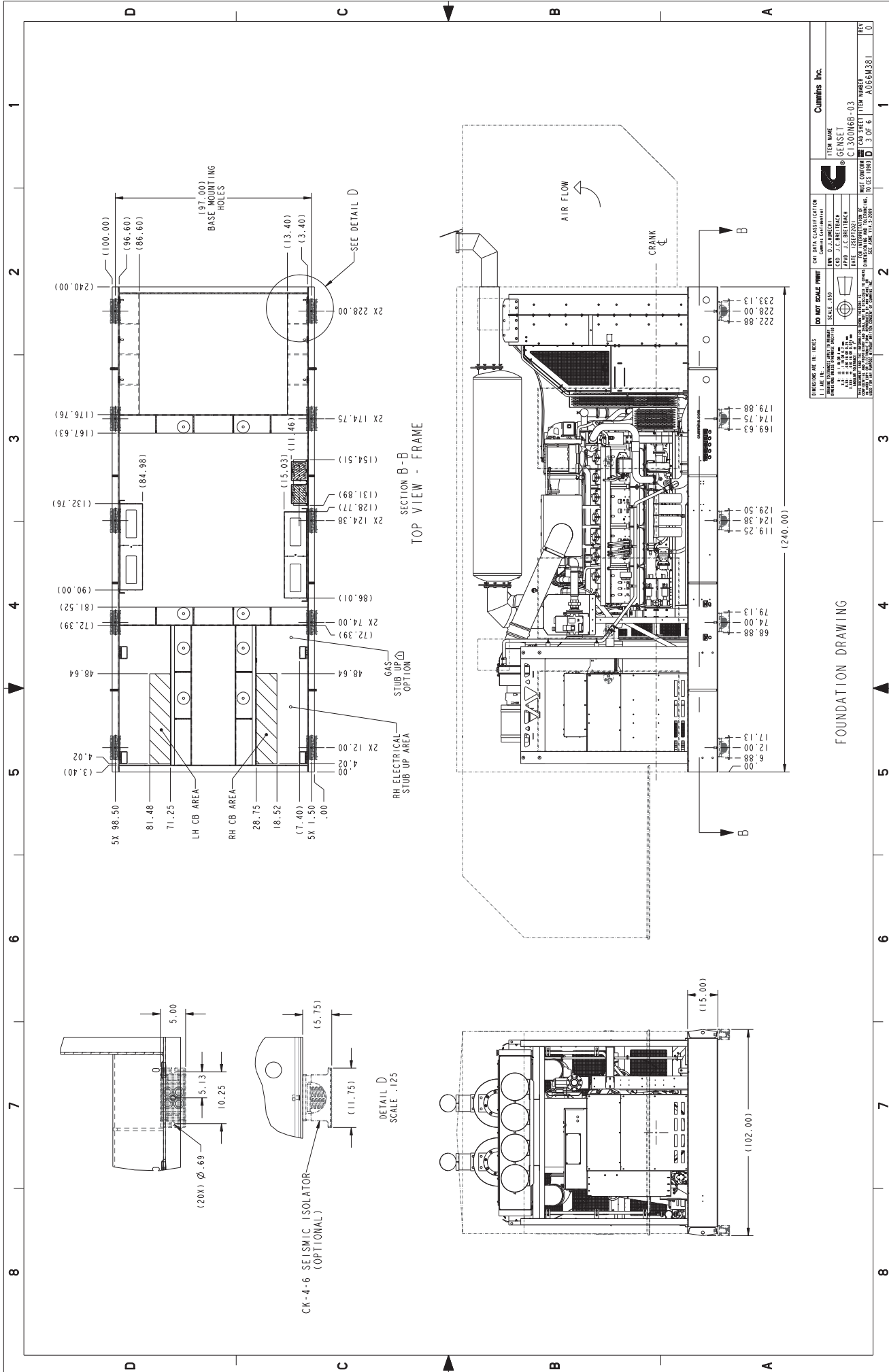

1 2 3 4 5 6 7 8

(1240.00)
(100.00)
(96.60)
(86.60)
(176.76)
(167.63)
(132.76)
(84.98)
(154.51)
(111.46)
(15.03)
(128.77)
(131.89)
(124.38)
(86.01)
(72.39)
(74.00)
2X 74.00
48.64
GAS STUB UP Δ OPTION
48.64
2X 12.00
4.00
RH ELECTRICAL STUB UP AREA
(3.40)
4.02
5X 98.50
81.48
71.25
LH CB AREA
RH CB AREA
28.75
18.52
(7.40)
5X 1.50
.00

(240.00)
233.13
222.88
228.00
179.88
169.63
174.75
129.50
119.25
119.25
79.13
74.00
68.88
17.13
12.00
6.88
0.00

ENGINEERING IN INCHES		DO NOT SCALE PRINT		REV	
DATE	SCALE	DATE	SCALE	BY	CHK
10/11/00	1/4" = 1'-0"	10/11/00	1/4" = 1'-0"	J.C. BREITENBACH	J.C. BREITENBACH
CUMMINS INC.		CUMMINS INC.		CUMMINS INC.	
TITAN NAME		TITAN NAME		TITAN NAME	
GENSET		GENSET		GENSET	
C1300N65-03		C1300N65-03		C1300N65-03	
MUST CONFORM TO THE LATEST REVISION OF THE CUMMINS SPECIFICATIONS FOR THIS PRODUCT.		MUST CONFORM TO THE LATEST REVISION OF THE CUMMINS SPECIFICATIONS FOR THIS PRODUCT.		MUST CONFORM TO THE LATEST REVISION OF THE CUMMINS SPECIFICATIONS FOR THIS PRODUCT.	
CUMMINS INC. 2500 N. LAKEVIEW AVENUE, PITTSBURGH, PA 15208		CUMMINS INC. 2500 N. LAKEVIEW AVENUE, PITTSBURGH, PA 15208		CUMMINS INC. 2500 N. LAKEVIEW AVENUE, PITTSBURGH, PA 15208	
© 1993 CUMMINS INC.		© 1993 CUMMINS INC.		© 1993 CUMMINS INC.	
REV		REV		REV	
D		D		D	
3 OF 6		3 OF 6		3 OF 6	
A066M331		A066M331		A066M331	
0		0		0	

FOUNDATION DRAWING

1 2 3 4 5 6 7 8

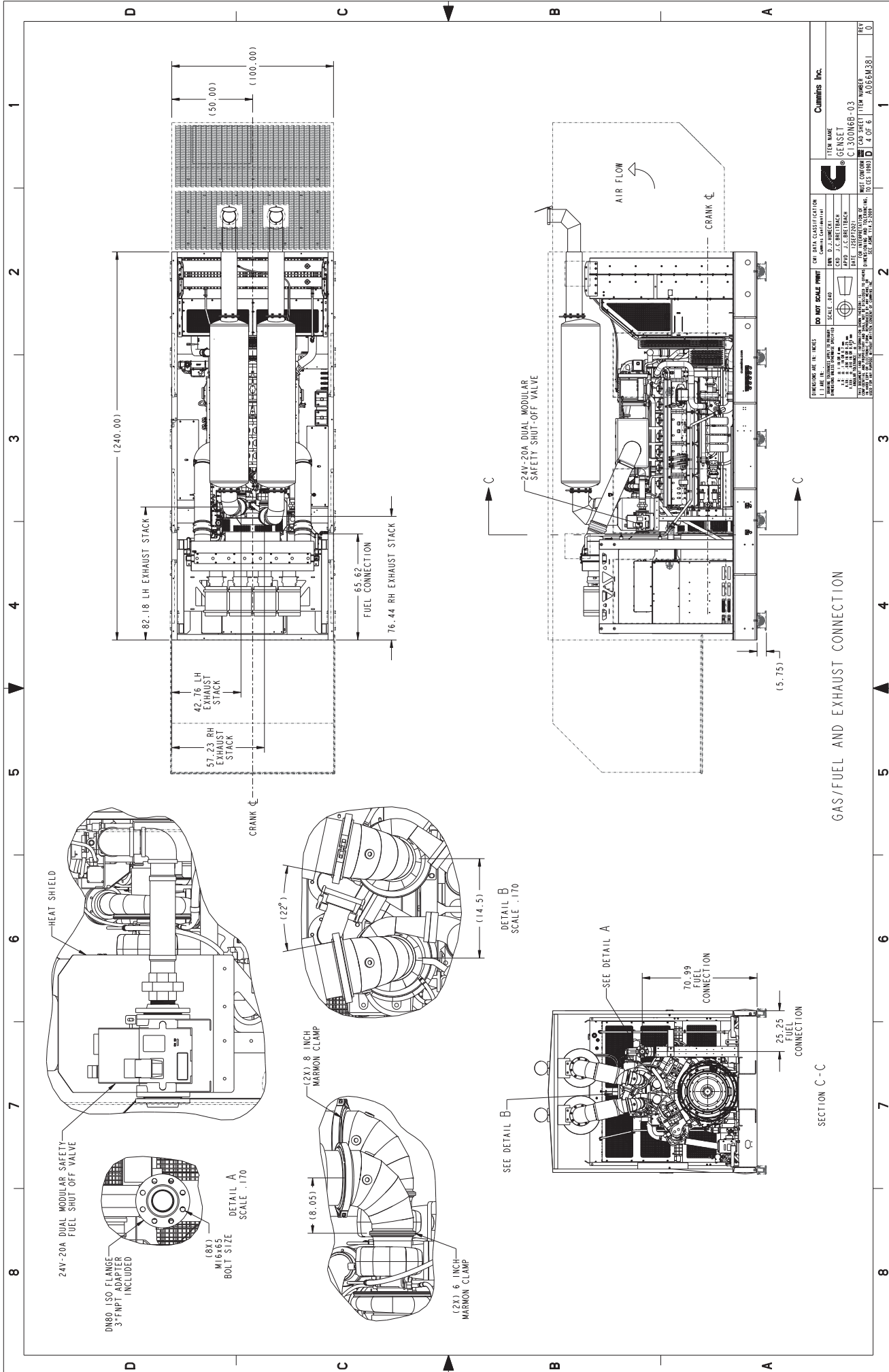

1 2 3 4 5 6 7 8

DO NOT SCALE PRINT DIMENSIONS ARE IN INCHES UNLESS OTHERWISE SPECIFIED FINISH: UNLESS SPECIFIED IN NOTES TOLERANCES: FRACTIONS: 1/16" MIN. DECIMALS: 0.005" MIN. HOLE DIMENSIONS: 0.005" MIN. UNLESS OTHERWISE SPECIFIED ALL DIMENSIONS UNLESS OTHERWISE SPECIFIED ARE TO CENTER UNLESS OTHERWISE SPECIFIED ALL DIMENSIONS UNLESS OTHERWISE SPECIFIED ARE TO CENTER UNLESS OTHERWISE SPECIFIED ALL DIMENSIONS UNLESS OTHERWISE SPECIFIED ARE TO CENTER UNLESS OTHERWISE SPECIFIED		ITEM NAME GENSET CUMMINS INC. C1300N65-03 CAD SHEET ITEM NUMBER C1300N65-03 4 OF 6 A06M331
SCALE 1:1 1/2" = 1'-0"	DATE 08/11/10	REV 0

SECTION C-C

GAS/FUEL AND EXHAUST CONNECTION

8 7 6 5 4 3 2 1

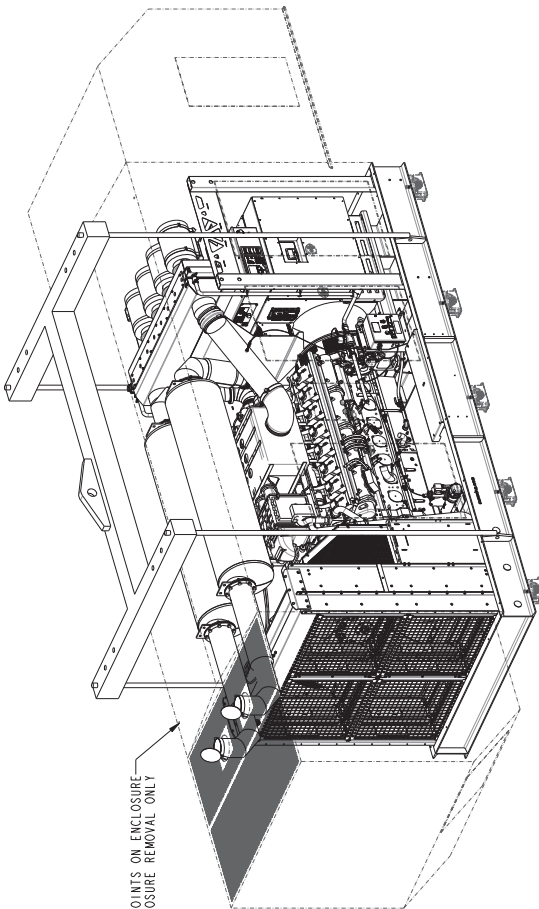

1. IDEAL ARRANGEMENT: LIFTING FRAME AND STRAPS

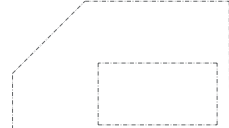
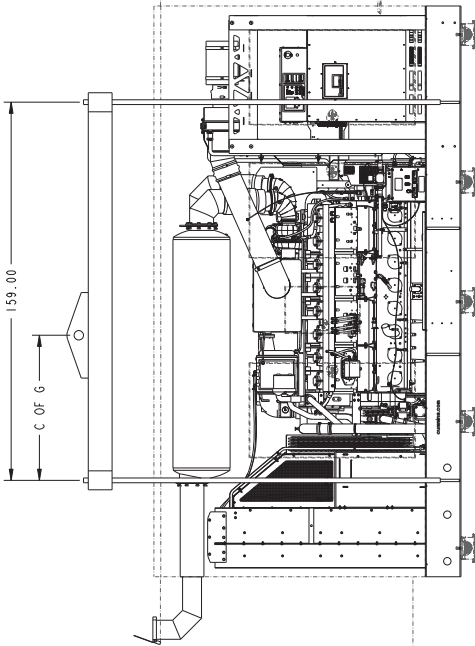
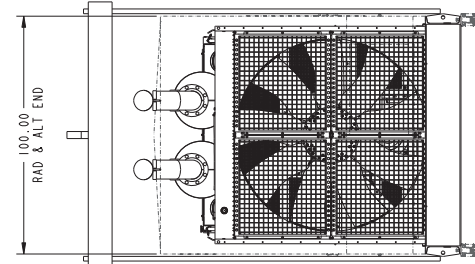

LIFTING ARRANGEMENT FOR GENSET
FOR C OF G VALUE REFER TO SHEET 2

DRAWING IS IN INCHES		DO NOT SCALE PRINT		GEN DATA CLASSIFICATION	
FORMING	MANUFACTURING	SCALE	SIZE	REV. NO.	DATE
1	1	1:1	11x17	1	11/13/03
DESIGNED BY	J. C. BREITENBERG	APPROVED BY	J. C. BREITENBERG	ITEM NAME	GENSET
DATE	11/13/03	DATE	11/13/03	ITEM NUMBER	C1300N65-03
THIS DRAWING IS THE PROPERTY OF CUMMINS INC. IT IS TO BE USED ONLY FOR THE PROJECT AND SITE SPECIFICALLY IDENTIFIED HEREON. IT IS NOT TO BE REPRODUCED, COPIED, OR TRANSMITTED IN ANY FORM OR BY ANY MEANS, ELECTRONIC OR MECHANICAL, INCLUDING PHOTOCOPYING, RECORDING, OR BY ANY INFORMATION STORAGE AND RETRIEVAL SYSTEM, WITHOUT THE WRITTEN PERMISSION OF CUMMINS INC.	MUST CONFORM TO THE REQUIREMENTS OF THE NATIONAL FIRE PROTECTION ASSOCIATION (NFPA) 704, 705, 706, 707, 708, 709, 710, 711, 712, 713, 714, 715, 716, 717, 718, 719, 720, 721, 722, 723, 724, 725, 726, 727, 728, 729, 730, 731, 732, 733, 734, 735, 736, 737, 738, 739, 740, 741, 742, 743, 744, 745, 746, 747, 748, 749, 750, 751, 752, 753, 754, 755, 756, 757, 758, 759, 760, 761, 762, 763, 764, 765, 766, 767, 768, 769, 770, 771, 772, 773, 774, 775, 776, 777, 778, 779, 780, 781, 782, 783, 784, 785, 786, 787, 788, 789, 790, 791, 792, 793, 794, 795, 796, 797, 798, 799, 800, 801, 802, 803, 804, 805, 806, 807, 808, 809, 810, 811, 812, 813, 814, 815, 816, 817, 818, 819, 820, 821, 822, 823, 824, 825, 826, 827, 828, 829, 830, 831, 832, 833, 834, 835, 836, 837, 838, 839, 840, 841, 842, 843, 844, 845, 846, 847, 848, 849, 850, 851, 852, 853, 854, 855, 856, 857, 858, 859, 860, 861, 862, 863, 864, 865, 866, 867, 868, 869, 870, 871, 872, 873, 874, 875, 876, 877, 878, 879, 880, 881, 882, 883, 884, 885, 886, 887, 888, 889, 890, 891, 892, 893, 894, 895, 896, 897, 898, 899, 900, 901, 902, 903, 904, 905, 906, 907, 908, 909, 910, 911, 912, 913, 914, 915, 916, 917, 918, 919, 920, 921, 922, 923, 924, 925, 926, 927, 928, 929, 930, 931, 932, 933, 934, 935, 936, 937, 938, 939, 940, 941, 942, 943, 944, 945, 946, 947, 948, 949, 950, 951, 952, 953, 954, 955, 956, 957, 958, 959, 960, 961, 962, 963, 964, 965, 966, 967, 968, 969, 970, 971, 972, 973, 974, 975, 976, 977, 978, 979, 980, 981, 982, 983, 984, 985, 986, 987, 988, 989, 990, 991, 992, 993, 994, 995, 996, 997, 998, 999, 1000		REV. NO.	DATE	
				1	11/13/03
				2	11/13/03
				3	11/13/03
				4	11/13/03
				5	11/13/03
				6	11/13/03
				7	11/13/03
				8	11/13/03

Cummins Inc.

GENSET
C1300N65-03

11/13/03

11/13/03

11/13/03

11/13/03

11/13/03

11/13/03

11/13/03

11/13/03

11/13/03

11/13/03

11/13/03

11/13/03

11/13/03

11/13/03

11/13/03

11/13/03

11/13/03

11/13/03

11/13/03

11/13/03

11/13/03

SECTION 7

START-UP AND WARRANTY





Cummins Sales and Service Customer / Contractor Pre Commissioning Inspection Form

The intent of this form is for the contractor to prepare for equipment to be commissioned by a certified Cummins Field Service Power Generation Technician. Filling out this form is required and will minimize delays due to equipment failing to meet requirements. Completing this checklist in its entirety should minimize the need for additional billing beyond the previously provided commissioning quote.

The items listed are the responsibility of the contractor and not Cummins Sales and Service.

Project Name/End User: _____

Contractor: _____

Address: _____ Contact: _____

Business Phone: _____ Cell Phone: _____

Email: _____

ON SITE INFORMATION

On-Site Contact Information: _____

Address: _____

Time Requested Onsite: _____

Sub location of Generator (ie. Roof, basement, floor): _____

Does the facility have the following: Loading Dock Elevator

Access (from truck and load bank parking to generator in feet): _____

Parking: Is parking available on-site for service truck: Yes No

Permits: Have all necessary air quality and local permits been secured: Yes No N/A

Fuel Tank Testing: Is fuel tank testing required: Yes No

If yes when is the inspector scheduled for: _____

ON SITE INFORMATION CONTINUED

YES	NA	NO
<input type="checkbox"/>	<input type="checkbox"/>	<input type="checkbox"/>
<input type="checkbox"/>	<input type="checkbox"/>	<input type="checkbox"/>
<input type="checkbox"/>	<input type="checkbox"/>	<input type="checkbox"/>

Is the facility occupied and is customer aware there will be power outages after generator is started?

Will there be any site safety training needed for technician prior to beginning? On site contact for training: _____

Will customer representative be on site for operator training?
On site contact for operator training: _____

MECHANICAL LOCATION AND PLACEMENT OF THE GENERATOR SET

YES	NA	NO
<input type="checkbox"/>	<input type="checkbox"/>	<input type="checkbox"/>
<input type="checkbox"/>	<input type="checkbox"/>	<input type="checkbox"/>
<input type="checkbox"/>	<input type="checkbox"/>	<input type="checkbox"/>
<input type="checkbox"/>	<input type="checkbox"/>	<input type="checkbox"/>

Generator is properly secured to pad or vibration isolators

Generator Enclosure and/or Room is free of all debris

No airflow obstructions to the engine or generator are present for cooling combustion
(See Cummins T-030 or Installation manual of generator set)

Room is designed for adequate inlet and outlet airflow

GASEOUS FUEL Natural Gas/LP Vapor/LP Liquid

YES	NA	NO
<input type="checkbox"/>	<input type="checkbox"/>	<input type="checkbox"/>
<input type="checkbox"/>	<input type="checkbox"/>	<input type="checkbox"/>
<input type="checkbox"/>	<input type="checkbox"/>	<input type="checkbox"/>
<input type="checkbox"/>	<input type="checkbox"/>	<input type="checkbox"/>

Natural gas and/or LPG fuel supply is connected.

Fuel piping is the appropriate size based on full-load CFH/BTU requirement. Pipe size after service regulator: _____

Service regulator(s), (if supplied), fuel strainer(s), flexible fuel line(s) and manual shut off are installed

Fuel pressure after service regulator is: _____ inches of H2O

I have read and fully understand the fuel requirements for this equipment, I am verifying that the piping and fuel supply meets or exceeds those requirements. I also understand failure to meet the requirements will result in additional charges.

Contractor "requestor" Signature

Date

DIESEL FUELED GENERATORS

YES NA NO

<input checked="" type="checkbox"/>	<input type="checkbox"/>	<input type="checkbox"/>
<input checked="" type="checkbox"/>	<input type="checkbox"/>	<input type="checkbox"/>
<input checked="" type="checkbox"/>	<input type="checkbox"/>	<input type="checkbox"/>
<input checked="" type="checkbox"/>	<input type="checkbox"/>	<input type="checkbox"/>

Flexible fuel connections, (supply and return) are connected to generator and piping.

Day tank installed, wired and plumbed (lines free of obstruction) to genset and main fuel tank if applicable. Only black iron pipe for fuel lines, never use copper or galvanized pipe.

All tanks filled with enough fuel to perform startup and testing.

A return line from engine to day tank and day tank to main tank should be in place

EXHAUST SYSTEM

YES NA NO

<input checked="" type="checkbox"/>	<input type="checkbox"/>	<input type="checkbox"/>
<input checked="" type="checkbox"/>	<input type="checkbox"/>	<input type="checkbox"/>
<input checked="" type="checkbox"/>	<input type="checkbox"/>	<input type="checkbox"/>
<input checked="" type="checkbox"/>	<input type="checkbox"/>	<input type="checkbox"/>

Exhaust wrapped or isolated to prevent accidental activation of fire protection devices and sprinklers.

Exhaust flex-pipe is installed at engine exhaust outlet (The silencer and flex-pipe are supplied with the generator set).

Silencer is installed with appropriate supports (no weight should be placed on the exhaust outlet of the genset).

Exhaust system has proper expansion joints and wall thimbles (Thimbles are required for wall or roof penetration).

GENERATOR ELECTRICAL CONNECTIONS

YES NA NO

<input checked="" type="checkbox"/>	<input type="checkbox"/>	<input type="checkbox"/>
<input checked="" type="checkbox"/>	<input type="checkbox"/>	<input type="checkbox"/>
<input checked="" type="checkbox"/>	<input type="checkbox"/>	<input type="checkbox"/>
<input checked="" type="checkbox"/>	<input type="checkbox"/>	<input type="checkbox"/>
<input checked="" type="checkbox"/>	<input type="checkbox"/>	<input type="checkbox"/>
<input checked="" type="checkbox"/>	<input type="checkbox"/>	<input type="checkbox"/>
<input checked="" type="checkbox"/>	<input type="checkbox"/>	<input type="checkbox"/>
<input checked="" type="checkbox"/>	<input type="checkbox"/>	<input type="checkbox"/>
<input checked="" type="checkbox"/>	<input type="checkbox"/>	<input type="checkbox"/>

Load conductors connected to breakers

Flexible connections used on all conduit connections to the generator set output box

Remote start interconnection **stranded** wiring is installed between the generator set and the automatic transfer switch(s) and annunciator.

AC Power conductors in dedicated conduit separate from any DC control or network wiring

Ground fault connected/functioning on generator, if supplied

AC power wired to the coolant heaters (Do NOT energize)

Check for AC oil pan heater, control heater or generator winding heater (Needing AC wiring)

Generator is grounded in compliance with local codes

If applicable, louver motors are operational and connected to generator controls

GENERATOR ELECTRICAL CONNECTIONS CONTINUED

YES NA NO

<input type="checkbox"/>	<input type="checkbox"/>	<input type="checkbox"/>
<input type="checkbox"/>	<input type="checkbox"/>	<input type="checkbox"/>
<input type="checkbox"/>	<input type="checkbox"/>	<input type="checkbox"/>

Annunciator mounted in a location where someone can observe a fault of the remote generator system

Where is annunciator located? _____

Are there additional ancillary devices/equipment that need to be integrated into the system? If yes, please define _____

Battery charger mounted (free of vibration, weather, accessible for an operator to observe easily) and connected to the appropriate AC and DC wiring to operate the charger.

TRANSFER SWITCH ELECTRICAL CONNECTIONS

YES NA NO

<input type="checkbox"/>	<input type="checkbox"/>	<input type="checkbox"/>
<input type="checkbox"/>	<input type="checkbox"/>	<input type="checkbox"/>
<input type="checkbox"/>	<input type="checkbox"/>	<input type="checkbox"/>

Conductors connected for Utility, Load and Emergency

Remote start interconnection **stranded** wiring is installed between the generator set and the automatic transfer switch(s).

Four Pole Transfer Switch: Is generator neutral grounded?

DAY OF STARTUP

YES NA NO

<input type="checkbox"/>	<input type="checkbox"/>	<input type="checkbox"/>
<input type="checkbox"/>	<input type="checkbox"/>	<input type="checkbox"/>
<input type="checkbox"/>	<input type="checkbox"/>	<input type="checkbox"/>

Training of facility personnel will be done on the same day as start up. Additional trips for operational training will be an additional charge.

Can transfer switch be tested at time of generator startup? (There will be a power interruption) **Note: After hours testing could result in additional charges.**

If the associated switchgear and/or ATS(s) are not provided by Cummins, will the manufacturer's representative be on site?

Exercise with or without load?

If known, Transfer Time delay set recommendations Generator Set to exercise Day: _____ Time: _____

Contractor "requestor" Signature

Printed Name

Date: _____

Please complete this form and return to schedule start up, if not returned within 5 business days prior to scheduled startup it may be delayed. I understand that the start-up date may have to be rescheduled at my expense if the above items have not been completed properly.

INSTRUCTION OF OPERATIONS AND MAINTENANCE PERSONNEL

Generator

PROJECT:

Training will be conducted by a factory-trained maintenance specialist in engine / generator maintenance and service. Training duration will be approximately 1 hour with a question and answer session to last as long as needed to satisfy owner.

LESSON PLAN

- I. Safety
 - a. General safety precautions
 - b. Equipment safety code
 - c. Electrical shock and arc flash
- II. Equipment Operation
 - a. Engine/generator operation process
 - b. Fundamental operating principals of the engine/generator
 - c. Identify all components of equipment – mechanical, electrical, and electronic
 - i. Standard operating procedures – start-up, monitoring, and shut-down
- III. Component Description
 - a. Identify each component's function – Engine/generator and Automatic Transfer Switch and their relationship to one another (if applicable)
- IV. Preventive Maintenance
 - a. Inspection Procedures
 - i. Inspection with equipment in operation
 - ii. Potential trouble symptoms
 - iii. Planned maintenance requirements and intervals
 - b. Procedures for testing equipment after maintenance has been performed
- V. Service Events
 - a. Alarms / Display Messages
 - b. Procedures
 - i. E-stop reset
 - c. Symptom list
 - d. Equipment Troubleshooting
 - e. Probable Cause & Recommended Correction

“HANDS-ON” DEMONSTRATION

The instructor will demonstrate the engine/generator functionality in auto and manual modes.

Disclaimer

Training is for informational purposes only. If you have any specific safety or operational questions refer to the Operators Manual and/or Sequence of Operations documentation.

INSTRUCTION OF OPERATIONS AND MAINTENANCE PERSONNEL

Transfer Switch

PROJECT:

Training will be conducted by a factory-trained maintenance specialist in transfer switches. Training duration will be approximately 1 hour with a question and answer session to last as long as needed to satisfy owner.

LESSON PLAN

- I. Safety
 - a. General safety precautions
 - b. Equipment safety code
 - c. Electrical shock and arc flash
- II. Introduction
 - a. Overview
- III. Components
 - a. External components
 - b. Controls / Instrument panels
 - c. Settings
- IV. Operating Instructions
 - a. Manual / Auto modes
 - b. How to change settings
 - c. Settings
 - d. Description of operation in transition phases
 - e. Bypass and Isolation (if applicable)
- V. Preventative Maintenance
 - a. Inspection Procedures
 - i. Inspection with equipment in operation
 - ii. Potential trouble symptoms
- VI. Planned Maintenance Requirements
 - a. Procedures for testing equipment after maintenance has been performed
- VII. Service Events
 - a. Alarms / Display messages
 - b. Procedures
 - c. Symptom list
- VIII. Troubleshooting
 - a. Probable cause and recommended correction

“HANDS-ON” DEMONSTRATION

The instructor will demonstrate the automatic transfer switch by simulating a power outage. This will allow the engine to start and pick up the emergency load. This will only be done with the owner's approval.

Disclaimer

Training is for informational purposes only. If you have any specific safety or operational questions refer to the Operators Manual and/or Sequence of Operations documentation.

Generator Planned Equipment Maintenance



INSPECTION

INTERVALS AVAILABLE: WEEKLY, MONTHLY, QUARTERLY, SEMI-ANNUALLY OR ANNUALLY

BATTERIES AND BATTERY CHARGER

- Visually inspect battery terminal connections
- Verify electrolyte level, vent caps of all cells in the starting battery system
- Visually inspect wiring, connections and insulation
- Record battery charging functions
- Record battery information
- Record battery condition test

FUEL SYSTEM

- Visually inspect ignition system (Natural Gas and Propane Only)
- Record primary tank fuel level
- Inspect engine fuel system for leaks
- Visually inspect all engine fuel hoses, clamps, pipes, components and fittings
- Visually inspect rupture/ containment basin
- Inspect day tank and controls (if applicable)
- Optional - fuel sample for laboratory analysis*

COOLING SYSTEM

- Record coolant level
- Visually inspect for coolant leaks
- Visually inspect drive belts condition
- Verify for proper coolant heater operation
- Record jacket water temperature
- Visually inspect fan, water pump, drives and pulleys
- Visually inspect all coolant hoses, clamps and connections
- Visually inspect radiator condition
- Visually inspect louver for damage
- Visually inspect fan hub and drive pulley for mechanical damage
- Record freeze point of antifreeze protection
- Record DCA level prior to changing coolant filter
- Optional - Coolant sample for laboratory analysis*

LUBRICATION SYSTEM

- Visually inspect engine oil leaks
- Visually inspect engine oil lines and connections
- Record oil level
- Optional - Oil sample for laboratory analysis*

GENSET CONTROLS AND ACCESSORIES

- Visually inspect all engine mounted wiring, senders and devices
- Visually inspect all control mounted components and wiring
- Verify all connecting plugs are tightened and in a good condition
- Visually inspect all accessory components and wiring
- Visually inspect and test lighting indicators

INTAKE AND EXHAUST SYSTEMS

- Visually inspect air filter and housing
- Visually inspect all engine piping and connections
- Record air cleaner restriction
- Visually inspect engine exhaust system for leaks
- Visually inspect rain cap
- Optional – Air filter replacement*
- Optional - Clean crankcase breather or replace filters*

GENERAL CONDITIONS

- Visually inspect governor linkage and oil level
- Visually inspect guards
- Visually inspect enclosure
- Visually inspect engine and generator mounts
- Verify emergency stop operation

TRANSFER SWITCH

- Visually inspect controls and time delay settings
- Verify function of exercise clock and record settings from controller
- Verify remote start control operation
- Record utility / source one voltage

AFTERTREATMENT (Upon request)

- Verify DEF level
- Record DPF restriction
- Visually inspect aftertreatment and controls

SWITCHGEAR (Upon Request)

- Inspection and Full Service quote available upon request.

FULL SERVICE

INCLUDES INSPECTION

OPERATIONAL & FUNCTIONAL REVIEW OF GENERATOR CRITICAL COMPONENTS

- Inspect engine cooling fan & fan drives for excessive wear or shaft wobble
- Check all pulleys, belt tensioners, slack adjusters & idler pulleys for travel, wear & overall condition
- Inspect / lubricate drive bearings, gear or belt drives, and other shaft connecting hardware

LUBRICATION OIL & FILTRATION SERVICE

- Change engine oil
- Change oil, fuel and water filters
- Post lube services operations of genset (unloaded) at rated temperature

* Additional Charge

Any additional repairs, parts, or service which are required will be brought to the attention of the owner. Repairs will only be made after proper authorization from the owner is given to Cummins. Any additional repairs, maintenance or service performed by Cummins or a Planned Equipment Maintenance Agreement holder will be at current Cummins labor rates.

Arc flash boundary and available incident energy shall be identified and marked on equipment being serviced or maintained.



Warranty Statement

Generator Sets

Commercial Standby Extended Warranty

Limited Standby 5 Year or 2,500 Hour Parts + Labor + Travel Extended Warranty – L189

Commercial Generating Set

When purchased, this limited extended warranty applies to all Cummins Power Generation® branded commercial generating sets and associated accessories (hereinafter referred to as "Product").

This warranty covers any failures of the Product, under normal use and service, which result from a defect in material or factory workmanship.

Warranty Period:

The warranty start date is the date of initial start up, first rental, demonstration or 18 months after factory ship date, whichever is sooner. The coverage duration is 5 years from warranty start date or 2,500 hours, whichever occurs first.

Emergency Standby Power (ESP) is defined as the maximum power available during a variable electrical power sequence, under the stated operating conditions, for which a generating set is capable of delivering in the event of a utility power outage. The permissible average power output over 24 hours of operation shall not exceed 70% of the ESP.

Cummins Power Generation® Responsibilities:

In the event of a failure of the Product during the extended warranty period due to defects in material or workmanship, Cummins Power Generation® will only be responsible for the following costs:

- All parts and labor required to repair the Product.
- Reasonable travel expenses to and from the Product site location.
- Maintenance items that are contaminated or damaged by a warrantable failure.

Owner Responsibilities:

The owner will be responsible for the following:

- Notifying Cummins Power Generation® distributor or dealer within 30 days of the discovery of failure.
- Installing, operating, commissioning and maintaining the Product in accordance with Cummins Power Generation®'s published policies and guidelines.
- Providing evidence for date of commissioning.
- Providing sufficient access to and reasonable ability to remove the Product from the installation in the event of a warrantable failure.

In addition, the owner will be responsible for:

- Incremental costs and expenses associated with Product removal and reinstallation resulting from non-standard installations.
- Costs associated with rental of generating sets used to replace the Product being repaired.
- Costs associated with labor overtime and premium shipping requested by the owner.
- All downtime expenses, fines, all applicable taxes, and other losses resulting from a warrantable failure.

Limitations:

This limited extended warranty does not cover Product failures resulting from:

- Inappropriate use relative to designated power rating.
- Inappropriate use relative to application guidelines.
- Failures due to normal wear, corrosion, varnished fuel system parts, lack of reasonable and necessary maintenance, unauthorized modifications and/or repair, and use of add-on or modified parts.
- Improper and/or unauthorized installation.
- Owner's or operator's negligence, accidents or misuse.
- Noncompliance with any Cummins Power Generation® published guideline or policy.
- Use of improper or contaminated fuels, coolants or lubricants.
- Improper storage before and after commissioning.
- Owner's delay in making Product available after notification of potential Product problem.
- Replacement parts and accessories not authorized by Cummins Power Generation®.
- Use of Battle Short Mode

Limitations Continued:

- Owner or operator abuse or neglect such as: operation without adequate coolant or lubricants; overfueling; overspeeding; lack of maintenance to lubricating, cooling or air intake systems; late servicing and maintenance; improper storage, starting, warm-up, run-in or shutdown practices, or for progressive damage resulting from a defective shutdown or warning device.
- Damage to parts, fixtures, housings, attachments and accessory items that are not part of the generating set.

This limited extended warranty does not cover costs resulting from:

- Difficulty in gaining access to the Product.
- Damage to customer property.
- Repair of cosmetic damage to enclosures.

Items not covered by this limited extended warranty:

- Batteries
- Enclosures
- Coolant heaters
- Exhaust systems and aftertreatment components
- Maintenance items

www.power.cummins.com

CUMMINS POWER GENERATION® RIGHT TO FAILED COMPONENTS:

Failed components claimed under warranty remain the property of Cummins Power Generation®. Cummins Power Generation® has the right to reclaim any failed component that has been replaced under warranty.

THE WARRANTIES SET FORTH HEREIN ARE THE SOLE WARRANTIES MADE BY CUMMINS POWER GENERATION ® IN REGARD TO THE PRODUCT. CUMMINS POWER GENERATION® MAKES NO OTHER WARRANTIES, EXPRESS OR IMPLIED, OR OF MERCHANTABILITY OR FITNESS FOR A PARTICULAR PURPOSE.

IN NO EVENT IS CUMMINS POWER GENERATION® LIABLE FOR INCIDENTAL OR CONSEQUENTIAL DAMAGES.

This limited extended warranty shall be enforced to the maximum extent permitted by applicable law. This limited extended warranty gives the owner specific rights that may vary from state to state or from jurisdiction to jurisdiction.

Product Model Number: _____

Product Serial Number: _____

Date in Service: _____

power.cummins.com

Copyright © 2017 Cummins Inc. All rights reserved.

Cummins, the “C” logo, PowerCommand, AmpSentry, and InPower are trademarks of Cummins Inc.

Other company, product, or service names may be trademarks or service marks of others.

Specifications are subject to change without notice.

