

EQUIPMENT:

180REOZJG EMERGENCY GENERATOR

<input type="checkbox"/> APPROVED, RELEASED TO MANUFACTURE	SIGNATURE _____
<input type="checkbox"/> APPROVED AS NOTED, RELEASED TO MANUFACTURE	
<input type="checkbox"/> REVISE AND RE-SUBMIT	DATE: _____

DATE: AUGUST 27, 2024

# GENERATOR WIRING REQUIREMENTS

BLOCK HEATER;  
120V/1PH/20A CIRCUIT

BATTERY CHARGER;  
120V/1PH/15A CIRCUIT

BATTERY HEATER  
120V/1PH/15A CIRCUIT

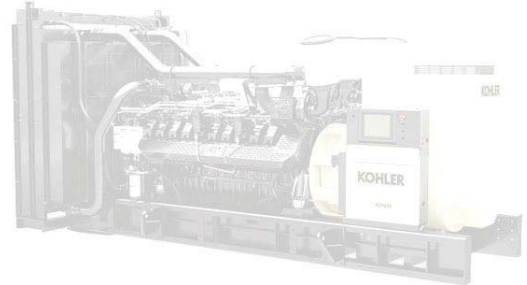

RSA III POWER;  
12V FUSED 1A CIRCUIT

TB2 - P=BATT POS (+), 7N=BATT NEG (-) AT APM402 IN GENERATOR  
P37-2 AND P37-3 ON RSA III

RSA III RS-485 COMMUNICATION;  
BELDEN 9841, MAX LENGTH 4000 FT.  
P21 ON APM402 CONTROLLER IN GENERATOR  
P27 ON RSA III REMOTE ANNUNCIATOR  
connect the "shield" wire at either end but not at both ends.

ATS AUTO/REMOTE START;  
2 WIRES 18-20 GAUGE  
TB3 - TERMINALS 3 & 4 ON APM402 CONTROLLER IN GENERATOR  
ENGINE START TERMINALS IN ATS  
**(DO NOT RUN WITH POWER WIRES OR 120V, MUST BE ISOLATED)**

Package



## TABLE OF CONTENTS

Section	Sub-Section	Literature
<b>Quote</b>		
Model 180REOZJG Spec Sheets		
<b>Specification Sheet</b>	Controller	G6-161
<b>Specification Sheet</b>	Circuit Breaker	G6-88
<b>Specification Sheet</b>	Circuit Breaker	Circuit Breaker Trip Curves
<b>Specification Sheet</b>	Battery Charger	G6-146
<b>Specification Sheet</b>	Weather/ Sound Enclosure Packaging	Enclosure Package
<b>Specification Sheet</b>	Engine Block Heater	G6-175
<b>Specification Sheet</b>	Engine Block Heater	G6-175
<b>Specification Sheet</b>	Remote Serial Annunciator	G6-139
Alternator Data		
	Alternator Data Sheet	4S12X
Sound Data		
	Sound Data Sheet	Sound Data
Cooling Data		
	Cooling Systems Data Sheet	Cooling Data
Exhaust System Data		
	Exhaust System Data	Exhaust System Data
Emissions Data		
	Emissions Data	Emissions Data
	EPA Certificate	EPA Certificate
Dimensional Drawings		
	Generator	ADV-8473
	Accessories	ADV-8474
	Controller	ADV-7935
	Enclosure	ADV-7854
	Remote Serial Annunciator	GM85123
	Subbase Tank	ADV-7859



## WiringSchematicDiagrams

Controller Schematic Diagram	ADV-8547
Controller Wiring Diagram	GM88841
Interconnection Diagram	GM78246
Remote Serial Annunciator	ADV-9169
Remote Serial Annunciator	GM62554
Voltage Diagram	ADV-5875

## Misc

Battery	244578
Battery Charger	GM87448
Battery Charger Assembly	GM103794
Battery Charger Assembly	GM94447
Battery Heater	GM103782
Block Heater	326220
Block Heater	GM75555
Circuit Breaker	GM85432
Circuit Breaker Mounting	ADV-7371
Emergency Stop	A222654

## Warranty

Warranty	TP-5374
----------	---------

## Certification

ISO9001 Certificate	G15-152
Prototype Test Summary	G18-460
Prototype Test Certificate	G18-56

## Pre-Startup Checklist

Pre-Startup Checklist	PreStartUpCheckList
-----------------------	---------------------

---

## Generator

---

### Kohler Model: 180REOZJG

This diesel generator set equipped with a 4S12X alternator operating at 277/480 volts is rated for 180 kW/225 kVA. Output amperage: 271.

Qty	Description																																																																						
	180REOZJG Generator System																																																																						
1	<p>180REOZJG Generator Set</p> <p>Includes the following:</p> <table border="0"> <tr> <td>Literature Languages</td> <td>English</td> </tr> <tr> <td>Approvals and Listings</td> <td>UL2200 Listing</td> </tr> <tr> <td>Engine</td> <td>180REOZJG, 24V, 50/60Hz</td> </tr> <tr> <td>Nameplate Rating</td> <td>Standby 130C Rise</td> </tr> <tr> <td>Voltage</td> <td>60Hz, 277/480V, Wye, 3Ph, 4W</td> </tr> <tr> <td>Alternator</td> <td>4S12X</td> </tr> <tr> <td>Cooling System</td> <td>Unit Mounted Radiator, 50C</td> </tr> <tr> <td>Skid and Mounting</td> <td>Skid</td> </tr> <tr> <td>Air Intake</td> <td>Standard Duty</td> </tr> <tr> <td>Controller</td> <td>APM402</td> </tr> <tr> <td>Enclosure Type</td> <td>Sound</td> </tr> <tr> <td>Enclosure Material</td> <td>Aluminum</td> </tr> <tr> <td>Enclosure Silencer</td> <td>Internal Silencer</td> </tr> <tr> <td>Fuel Tank Type</td> <td>Standard</td> </tr> <tr> <td>Fuel Runtime (Approx.)</td> <td>24 Hours</td> </tr> <tr> <td>Subbase Fuel Tank Capacity</td> <td>400 Gallons</td> </tr> <tr> <td>Starting Aids, Installed</td> <td>1800W,110-120V</td> </tr> <tr> <td>Electrical Accy.,Installed</td> <td>Battery, 2/12V, Wet</td> </tr> <tr> <td>Electrical Accy.,Installed</td> <td>Battery Charger, 10A</td> </tr> <tr> <td>Rating, LCB 1</td> <td>80% Rated</td> </tr> <tr> <td>Amps, LCB 1</td> <td>400</td> </tr> <tr> <td>Trip Type, LCB 1</td> <td>Electronic, LSI</td> </tr> <tr> <td>Interrupt Rating LCB 1</td> <td>35kA at 480V</td> </tr> <tr> <td>Rating, LCB 2</td> <td>80% Rated</td> </tr> <tr> <td>Amps, LCB 2</td> <td>400</td> </tr> <tr> <td>Trip Type, LCB 2</td> <td>Electronic, LSI</td> </tr> <tr> <td>Interrupt Rating LCB 2</td> <td>35kA at 480V</td> </tr> <tr> <td>LCB Accy. Installed</td> <td>Breaker Separation Between LCB</td> </tr> <tr> <td>Fuel Lines, Installed</td> <td>Flexible Fuel Lines</td> </tr> <tr> <td>Miscellaneous Accy,Installed</td> <td>Coolant in Genset</td> </tr> <tr> <td>Miscellaneous Accy,Installed</td> <td>Skid Extension &amp; Caps</td> </tr> <tr> <td>Warranty</td> <td>Standard</td> </tr> <tr> <td>Testing, Additional</td> <td>Power Factor Test,0.8,3Ph Only</td> </tr> <tr> <td>Total unit length in inches</td> <td>172</td> </tr> <tr> <td>Total unit width in inches</td> <td>53</td> </tr> </table>	Literature Languages	English	Approvals and Listings	UL2200 Listing	Engine	180REOZJG, 24V, 50/60Hz	Nameplate Rating	Standby 130C Rise	Voltage	60Hz, 277/480V, Wye, 3Ph, 4W	Alternator	4S12X	Cooling System	Unit Mounted Radiator, 50C	Skid and Mounting	Skid	Air Intake	Standard Duty	Controller	APM402	Enclosure Type	Sound	Enclosure Material	Aluminum	Enclosure Silencer	Internal Silencer	Fuel Tank Type	Standard	Fuel Runtime (Approx.)	24 Hours	Subbase Fuel Tank Capacity	400 Gallons	Starting Aids, Installed	1800W,110-120V	Electrical Accy.,Installed	Battery, 2/12V, Wet	Electrical Accy.,Installed	Battery Charger, 10A	Rating, LCB 1	80% Rated	Amps, LCB 1	400	Trip Type, LCB 1	Electronic, LSI	Interrupt Rating LCB 1	35kA at 480V	Rating, LCB 2	80% Rated	Amps, LCB 2	400	Trip Type, LCB 2	Electronic, LSI	Interrupt Rating LCB 2	35kA at 480V	LCB Accy. Installed	Breaker Separation Between LCB	Fuel Lines, Installed	Flexible Fuel Lines	Miscellaneous Accy,Installed	Coolant in Genset	Miscellaneous Accy,Installed	Skid Extension & Caps	Warranty	Standard	Testing, Additional	Power Factor Test,0.8,3Ph Only	Total unit length in inches	172	Total unit width in inches	53
Literature Languages	English																																																																						
Approvals and Listings	UL2200 Listing																																																																						
Engine	180REOZJG, 24V, 50/60Hz																																																																						
Nameplate Rating	Standby 130C Rise																																																																						
Voltage	60Hz, 277/480V, Wye, 3Ph, 4W																																																																						
Alternator	4S12X																																																																						
Cooling System	Unit Mounted Radiator, 50C																																																																						
Skid and Mounting	Skid																																																																						
Air Intake	Standard Duty																																																																						
Controller	APM402																																																																						
Enclosure Type	Sound																																																																						
Enclosure Material	Aluminum																																																																						
Enclosure Silencer	Internal Silencer																																																																						
Fuel Tank Type	Standard																																																																						
Fuel Runtime (Approx.)	24 Hours																																																																						
Subbase Fuel Tank Capacity	400 Gallons																																																																						
Starting Aids, Installed	1800W,110-120V																																																																						
Electrical Accy.,Installed	Battery, 2/12V, Wet																																																																						
Electrical Accy.,Installed	Battery Charger, 10A																																																																						
Rating, LCB 1	80% Rated																																																																						
Amps, LCB 1	400																																																																						
Trip Type, LCB 1	Electronic, LSI																																																																						
Interrupt Rating LCB 1	35kA at 480V																																																																						
Rating, LCB 2	80% Rated																																																																						
Amps, LCB 2	400																																																																						
Trip Type, LCB 2	Electronic, LSI																																																																						
Interrupt Rating LCB 2	35kA at 480V																																																																						
LCB Accy. Installed	Breaker Separation Between LCB																																																																						
Fuel Lines, Installed	Flexible Fuel Lines																																																																						
Miscellaneous Accy,Installed	Coolant in Genset																																																																						
Miscellaneous Accy,Installed	Skid Extension & Caps																																																																						
Warranty	Standard																																																																						
Testing, Additional	Power Factor Test,0.8,3Ph Only																																																																						
Total unit length in inches	172																																																																						
Total unit width in inches	53																																																																						

	Total unit height in inches	106
	Total unit weight (lbs)	6,387
	Weight/Dimensions Disclaimer *	Estimates-Not for Construction
1	Remote Emergency Stop Switch	
1	Battery Heater, 120V, 2/80W	
1	Lit Kit, 180REOZJG,General Maintenance	
1	RSA III, Annunciator only	

**KOHLER.**

# Spec Sheets

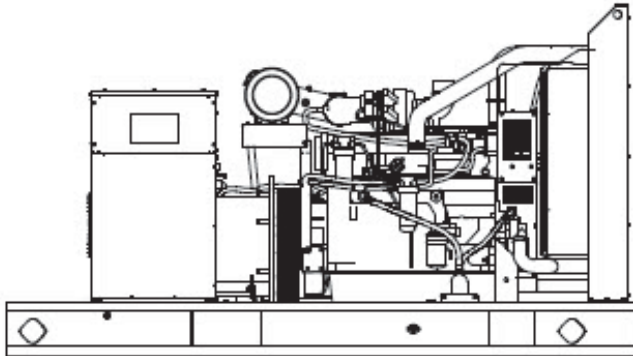

## Standard Features

- Kohler Co. provides one-source responsibility for the generating system and accessories.
- Approved for use with certified renewable Hydrotreated Vegetable Oil (HVO) / Renewable Diesel (RD) fuels compliant with EN15940/ASTM D975.
- The generator set and its components are prototype-tested, factory-built, and production-tested.
- The 60 Hz generator set offers a UL 2200 listing.
- The generator set accepts rated load in one step.
- The 60 Hz generator set meets NFPA 110, Level 1, when equipped with the necessary accessories and installed per NFPA standards.
- A one-year limited warranty covers all systems and components. Two- and five-year extended warranties are also available.
- Tier 3 EPA-certified for Stationary Emergency Applications
- Alternator Protection
- Battery Rack and Cables
- Customer Connection (standard with Decision-Maker 6000 controller only)
- Local Emergency Stop Switch
- Oil Drain Extension
- Operation and Installation Literature

## Alternator Features

- The unique Fast-Response X excitation system delivers excellent voltage response and short circuit capability using a rare-earth, permanent magnet (PM)-excited alternator.
- The brushless, rotating-field alternator has broad range reconnectability.

## Other Features

- Kohler designed controllers for one-source system integration and remote communication.
- The low coolant level shutdown prevents overheating. Integral vibration isolation eliminates the need for under-unit vibration spring isolators.
- Mount up to three circuit breakers to allow circuit protection of selected priority loads.

## Generator Set Rating

Alternator	Voltage	Ph	Hz	Peak kVA	Standby 130C Rise Ratings	
					kW/kVA	Amps
4S12X	277/480	480	60	480	180/225	271

RATINGS: All three-phase units are rated at 0.8 power factor. All single-phase units are rated at 1.0 power factor.

Standby Ratings: The standby rating is applicable to varying loads for the duration of a power outage. There is no overload capability for this rating.

Prime Power Ratings: At varying load, the number of generator set operating hours is unlimited.

A 10% overload capacity is available for one hour in twelve. Ratings are in accordance with ISO-8528-1 and ISO-3046-1. For limited running time and continuous ratings, consult the factory.

Obtain technical information bulletin (TIB-101) for ratings guidelines, complete ratings definitions, and site condition derates.

The generator set manufacturer reserves the right to change the design or specifications without notice and without any obligation or liability whatsoever.

## Model: 180REOZJG, continued

### Alternator Specifications

Specifications	Alternator
Alternator manufacturer	Kohler
Type	4-Pole, Rotating-Field
Exciter type	Brushless, Rare-Earth Permanent-Magnet
Leads, quantity	12, Reconnectable
Voltage regulator	Solid State, Volts/Hz
Insulation	NEMA MG1
Insulation: Material	Class H
Insulation: Temperature Rise	130°C, Standby
Bearing: quantity, type	1, Sealed
Coupling	Flexible Disc
Amortisseur windings	Full
Voltage regulation, no-load to full-load RMS	Controller Dependent
One-Step Load Acceptance	100% of rating
Unbalanced load capability	100% of Rated Standby Current
<ul style="list-style-type: none"><li>• NEMA MG1, IEEE, and ANSI standards compliance for temperature rise and motor starting.</li><li>• Sustained short-circuit current of up to 300% of the rated current for up to 10 seconds.</li><li>• Sustained short-circuit current enabling down stream circuit breakers to trip without collapsing the alternator field.<ul style="list-style-type: none"><li>• Self-ventilated and dripproof construction.</li></ul></li><li>• Vacuum-impregnated windings with fungus-resistant epoxy varnish for dependability and long life.<ul style="list-style-type: none"><li>• Superior voltage waveform from a two-thirds pitch stator and skewed rotor.</li></ul></li></ul>	

### Engine

#### Engine Specification

Engine Manufacturer	John Deere
Engine Model	6068HFG82E
Engine: type	4-Cycle, Turbocharged, Charge Air-Cooled
Cylinder arrangement	6 Inline
Displacement, L (cu. in.)	6.8 (415)
Bore and stroke, mm (in.)	106 x 127 (4.19 x 5.00)
Compression ratio	17.0:1
Piston speed, m/min. (ft./min.)	457 (1500)
Main bearings: quantity, type	7, Replaceable Insert
Rated rpm	1800
Max. power at rated rpm, kWm (BHP)	212 (284)
Cylinder head material	Cast Iron
Crankshaft material	Forged Steel
Valve (exhaust) material Intake	Chromium-Silicon Steel
Valve (exhaust) material	Stainless Steel
Governor: type, make/model	JDEC Electronic L14 Denso HP3
Frequency regulation, no-load to-full load	Isochronous
Frequency regulation, steady state	±0.25%
Frequency	Field-Convertible
Air cleaner type, all models	Dry

## Model: 180REOZJG, continued

### Exhaust

#### Exhaust System

Exhaust Manifold Type	Dry
Exhaust flow at rated kW, m <sup>3</sup> /min. (cfm)	29.9 (1056)
Exhaust temperature at rated kW, dry exhaust, °C (°F)	483 (901)
Maximum allowable back pressure, kPa (in. Hg)	Min 3 (1.13) Max 7.5 (2.2)

### Engine Electrical

#### Engine Electrical System

Battery charging alternator	24 Volt
Battery charging alternator: Ground (negative/positive)	Negative
Battery charging alternator: Volts (DC)	24
Battery charging alternator: Ampere rating	45
Starter motor rated voltage (DC)	24
Battery, recommended cold cranking amps (CCA): Qty., CCA rating each	Two, 925
Battery voltage (DC)	12

### Fuel

#### Fuel System

Fuel type	Diesel
Fuel supply line, min. ID, mm (in.)	11.0 (0.44)
Fuel return line, min. ID, mm (in.)	6.0 (0.25)
Max. lift, fuel pump: type, m (ft.)	Electronic, 1.8 (6.0)
Max. fuel flow, Lph (gph)	92.7 (24.5)
Max. fuel pump restriction, kPa (in. Hg)	20 (5.9)
Fuel prime pump	Manual
Fuel Filter Secondary	2 Microns @ 98% Efficiency
Fuel Filter Primary	30 Microns
Fuel Filter Water Separator	Yes
Recommended fuel	#2 Diesel/HVO/RD

### Lubrication

#### Lubrication System

Type	Full Pressure
Oil pan capacity, L (qt.)	32.5 (34.4)
Oil pan capacity with filter, L (qt.)	33.4 (35.3)
Oil filter: quantity, type	1, Cartridge
Oil cooler	Water-cooled

## Model: 180REOZJG, continued

### Cooling

#### Radiator System

Ambient temperature, °C (°F)	50 (122)
Engine jacket water capacity, L (gal.)	11.9 (3.2)
Radiator system capacity, including engine, L (gal.)	27.6 (7.3)
Engine jacket water flow, Lpm (gpm)	180 (48)
Heat rejected to cooling water at rated kW, dry exhaust, kW (Btu/min.)	85.2 (4850)
Heat rejected to air charge cooler at rated kW, dry exhaust, kW (Btu/min.)	47.3 (2692)
Water pump type	Centrifugal
Fan diameter, including blades, mm (in.)	787 (31)
Fan, kWm (HP)	10.1 (13.5)
Max. restriction of cooling air, intake and discharge side of radiator, kPA (in. H2O)	0.125 (0.5)

\* Enclosure with enclosed silencer reduces ambient temperature capability by 5°C (9°F).

### Operation Requirements

#### Air Requirements

Radiator-cooled cooling air, m3/min. (scfm) *	368.1 (13000)
Combustion air, m3/min. (cfm)	16.4 (579)
Heat rejected to ambient air: Engine, kW (Btu/min.)	37.7 (2152)
Heat rejected to ambient air: Alternator, kW (Btu/min.)	14.4 (820)

\*Air density = 1.20 kg/m3 (0.075 lbf/ft3)

### Fuel Consumption

Diesel, Lph (gph), at % load	Rating
Standby Fuel Consumption at 100% load	51.8 Lph (13.7 gph)
Standby Fuel Consumption at 75% load	42.7 Lph (11.3 gph)
Standby Fuel Consumption at 50% load	28.9 Lph (7.6 gph)
Standby Fuel Consumption at 25% load	16.6 Lph (4.4 gph)
Prime Fuel Consumption at 100% load	48.4 Lph (12.8 gph)
Prime Fuel Consumption at 75% load	39.9 Lph (10.6 gph)
Prime Fuel Consumption at 50% load	26.7 Lph (7.0 gph)
Prime Fuel Consumption at 25% load	15.3 Lph (4.1 gph)
Continuous Fuel Consumption at 0% load	Fuel consumption is up to 4% higher when using HVO/RD than #2 ULSD.

### Dimensions and Weights

#### Dim Weight Spec

#### Dim Weight Value

Fuel	Diesel
Engine Manufacturer	Diesel
Overall Size, L x W x H, mm (in.):	3000 x 1300 x 1668 (118.1 x 51.2 x 65.7)
Weight (radiator model), wet, kg (lb.):	1147 (3190)

**Model: 180REOZJG, continued**

---

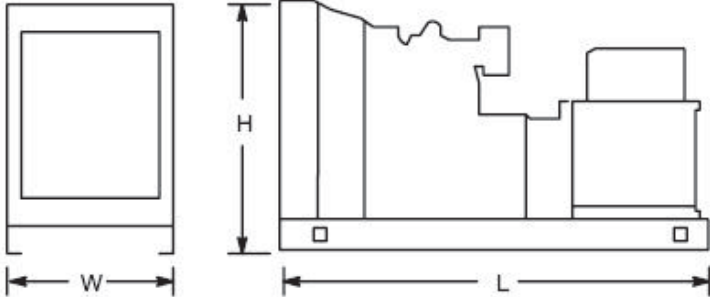

NOTE: This drawing is provided for reference only and should not be used for planning installation. Contact your local distributor for more detailed information.

## Kohler® APM402 Controller

### General Description and Function

The APM402 generator set controller provides advanced control, system monitoring, and system diagnostics for optimum performance.

The APM402 controller meets NFPA 110, Level 1 when equipped with the necessary accessories and installed per NFPA standards.

The APM402 controller uses a patented hybrid voltage regulator and unique software logic to manage alternator thermal overload protection features normally requiring additional hardware. Additional features include:

- A digital display and pushbutton/rotary selector dial provide easy local access to data.
- Measurements selectable in metric or English units.
- The controller can communicate directly with a personal computer via a network or serial configuration using SiteTech™ or Monitor III software.
- The controller supports Modbus® protocol. Use with serial bus or Ethernet networks. (Ethernet requires an external Modbus®/Ethernet converter module.)
- Scrolling display shows critical data at a glance.
- Digital display of power metering (kW and kVA).
- Integrated hybrid voltage regulator providing  $\pm 0.5\%$  regulation.
- Built-in alternator thermal overload protection.

Modbus® is a registered trademark of Schneider Electric.



**APM402**

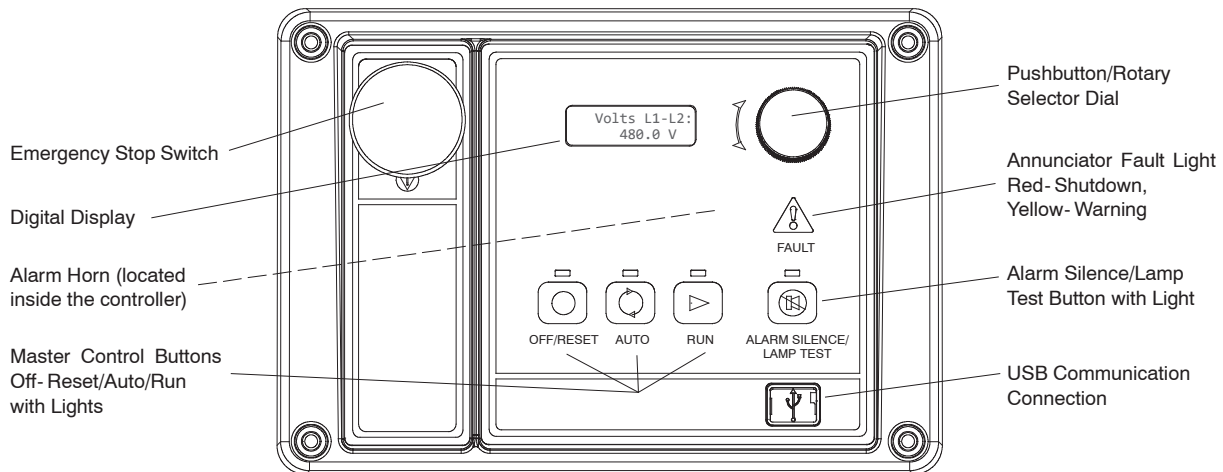

## User Interface Controls and Components

- Emergency stop switch
- Backlit LCD digital display with two lines of 12 characters (see *User Interface Displays for menus*)
- Alarm horn indicates generator set shutdown and warning faults
- Environmentally sealed membrane keypad with three master control buttons with lights
  - Off/Reset (red)
  - Auto (green)
  - Run (yellow)
- Pushbutton/rotary selector dial for menu navigation
  - Rotate dial to access main menus
  - Push dial and rotate to access sub menus
  - Press dial for 3 seconds to return to top of main menu
- Annunciator fault light
  - System shutdown (red)
  - System warning (yellow)
- Alarm silence/lamp test button
  - Alarm silence
  - Lamp test
- USB and RS-485 connections
  - Allows software upgrades
  - Provides access for diagnostics
  - PC communication using SiteTech™ or Monitor III software
- Dedicated user inputs
  - Remote emergency stop switch
  - Remote 2-wire start for transfer switch
  - Auxiliary shutdown
- Integrated hybrid voltage regulator
- Auto-resettable circuit protection mounted on circuit board.
- One relay output standard. Optional five relay output available.
- One analog and three digital inputs standard. Optional two inputs available.

## NFPA 110 Requirements

In order to meet NFPA 110, Level 1 requirements, the generator set controller monitors the engine/generator functions/faults shown below.

- Engine functions:
  - Overcrank
  - Low coolant temperature warning
  - High coolant temperature warning
  - High coolant temperature shutdown
  - Low oil pressure shutdown
  - Low oil pressure warning
  - High engine speed
  - Low fuel (level or pressure) \*
  - Low coolant level
  - EPS supplying load
  - High battery voltage
  - Low battery voltage
- General functions:
  - Master switch not in auto
  - Battery charger fault \*
  - Lamp test
  - Contacts for local and remote common alarm
  - Audible alarm silence button
  - Remote emergency stop \*

\* Function requires optional input sensors or kits and is engine dependent, see Controller Displays as Provided by the Engine ECM.

## User Interface Displays

The listing below has ● denoting main menus and ○ denoting sub-menus.

- Overview
  - Software version
  - Active shutdowns and warnings (if any are present)
  - Engine run time, total hours
  - Average voltage line-to-line
  - Frequency
  - Average current
  - Coolant temperature
  - Fuel level or pressure \*
  - Oil pressure
  - Battery voltage
- Engine Metering
  - Engine speed
  - Oil pressure
  - Coolant temperature
  - Battery voltage
- Generator Metering
  - Total power, VA
  - Total power, W
  - Rated power, %
  - Voltage, L- L and L- N for all phases
  - Current, L1, L2, L3
  - Frequency
- GenSet Information
  - Generator set model number
  - Generator set serial number
  - Controller serial number
- GenSet Run Time
  - Engine run time, total hours
  - Engine loaded, hours
  - Number of engine starts
  - Total energy, kWh
- GenSet System
  - System voltage
  - System frequency, 50 or 60 Hz
  - System phase, single or three (wye or delta)
  - Power rating, kW
  - Amp rating
  - Power type, standby or prime
  - Measurement units, metric or English (user selectable)
  - Alarm silence, always or auto only (NFPA 110)
  - Manual speed adjust \*
- GenSet Calibration
  - Voltage, L- L and L- N for all phases
  - Current, L1, L2, L3
  - Reset calibration
- Voltage Regulation
  - Adjust voltage, ±10%
- Digital Inputs
  - Input settings and status
- Digital Outputs
  - Output settings and status
- Analog Inputs
  - Input settings and status
- Event Log
  - Event history (stores up to 1000 system events)
- Selector Switch (requires initial activation by SiteTech™)

## Controller Features

- **AC Output Voltage Regulator Adjustment.** The voltage adjustment provides a maximum of  $\pm 10\%$  of the system voltage.
- **Alarm Silence.** The controller can be set up to silence the alarm horn only when in the AUTO mode for NFPA-110 application or Always for user convenience.
- **Alternator Protection.** The controller provides generator set overload and short circuit protection matched to each alternator for the particular voltage/phase configuration.
- **Automatic Restart.** The controller automatic restart feature initiates the start routine and re crank after a failed start attempt.
- **Common Failure Relay.** This relay is integrated on the controller circuit board. Contacts are rated 2 amps at 32 VDC or 0.5 amp at 120 VAC.
- **Communication.** Controller communication is available.
- **Cyclic Cranking.** The controller has programmable cyclic cranking.
- **ECM Diagnostics.** The controller displays engine ECM fault code descriptions to help in engine troubleshooting.
- **Engine Start Aid.** The starting aid feature provides control for an optional engine starting aid.
- **Event Logging.** The controller keeps a record (up to 1000 entries) for warning and shutdown faults. This fault information becomes a stored record of system events and can be reset.
- **Historical Data Logging.** Total number of generator set successful starts is recorded and displayed.
- **Integrated Hybrid Voltage Regulator.** The voltage regulator provides  $\pm 0.5\%$  no-load to full-load regulation with three-phase sensing.
- **Lamp Test.** Press the alarm silence/lamp test button to verify functionality of the indicator lights.
- **LCD Display.** Adjustable contrast for improving visibility.
- **Measurement Units.** The controller provides selection of English or metric displays.
- **Power Metering.** Controller digital display provides kW and kVA.
- **Programming Access (USB).** Provides software upgrades and diagnostics.
- **Remote Reset.** The remote reset function resets faults and allows restarting of the generator set without going to the master control switch off/reset position.
- **Remote Monitoring Panel.** The controller is compatible with the Kohler® Remote Serial Annunciator.
- **Run Time Hourmeter.** The generator set run time is displayed.
- **Time Delay Engine Cooldown (TDEC).** The TDEC provides a time delay before the generator set shuts down.
- **Time Delay Engine Start (TDES).** The TDES provides a time delay before the generator set starts.
- **Voltage Selection Menu.** This menu provides the capability of quickly switching controller voltage calibrations. Requires initial activation using SiteTech™ software. **NOTE:** Generator set output leads require voltage reconnection.

## Controller Functions

The following chart shows which functions cause a warning or shutdown. All functions are available as relay outputs.

**Warning** causes the fault light to show yellow and sounds the alarm horn signaling an impending problem.

**Shutdown** causes the fault light to show red, sounds the alarm horn, and stops the generator set.

	Warning Function	Shutdown Function
<b>Engine Functions</b>		
Critically high fuel level *	○	
ECM communication loss		●
ECM diagnostics	●	●
Engine over speed		●†
Engine start aid active		
Engine under speed		●
Fuel tank leak *	○	○
High battery voltage	●	
High coolant temperature	●	●†
High fuel level *	○	
Low battery voltage	●	
Low coolant level		●
Low coolant temperature	●	
Low cranking voltage	●	
Low engine oil level *	○	○
Low fuel level (diesel models) *	○	○
Low fuel pressure (gas models) *	○	
Low oil pressure	●	●†
No coolant temperature signal		●
No oil pressure signal		●
Overcrank		●†
Speed sensor fault	●	
<b>General Functions</b>		
Alarm horn silenced		
Analog inputs	○	○
Battery charger fault *	●	
Chicago code active *		
Common fault (includes †)		●
Common warning	●	
Digital inputs	○	○
Emergency stop		●†
Engine cooldown (delay) active		
Engine start delay active		
Engine started		
Engine stopped		
EPS supplying load		
Generator running		
Input/output communication loss	●	
Internal failure		●
Master switch not in auto	●	
NFPA 110 alarm active		
Remote start		
System ready		
<b>Generator Functions</b>		
AC sensing loss	●	●
Alternator protection		●
Ground fault input *	●	
kW overload		●
Locked rotor		●
Overfrequency		●
Overvoltage (each phase)		●
Underfrequency		●
Undervoltage (each phase)		●

● Standard function

○ Available user function

\* Function requires optional input sensors or kits and is engine dependent; see Controller Displays as Provided by the Engine ECM.

† Items included with common fault shutdown



KOHLER CO., Kohler, Wisconsin 53044 USA  
 Phone 920-457-4441, Fax 920-459-1646  
 For the nearest sales and service outlet in the  
 US and Canada, phone 1-800-544-2444  
 KOHLERPower.com

Controller Displays as Provided by the Engine ECM	Engine Manufacturer (and Model)						
	Kohler Diesel (KDI M, TM*)	Kohler Diesel (KDI TCR)	Kohler Gas (KG2204, KG2204T)	Kohler Gas (KG6208, KG6208T, KG10V08, KG10V08T)	GM and PSI/Doosan	John Deere	Volvo
Intake air pressure							D
Intake air Temperature		D		D	D	D	D
Coolant level			D	D	D	D	D
Coolant temperature		D	C/S/D	C/S/D	C/S/D	C/S/D	C/S/D
Crankcase pressure							D
ECM battery voltage	S		S/D	S	S		
Engine speed	C/S/D	C/S/D	C/S/D	C/S/D	C/S/D	C/S/D	C/S/D
Fuel pressure		D		C/S/D	C/S/D	C/S†	C/S/D
Fuel temperature		D				S/D	S
Oil level				S†	S†	S†	S†
Oil pressure		C/S/D	D	C/S/D	C/S/D	C/S/D	C/S/D
Oil temperature			S				SD

C = Value displayed on controller, S = Value displayed in Site Tech, D = ECU diagnostic is supported  
 \* Electronic governor and ECM are optional on KDI M and TM engines.  
 † Controller uses local analog input to obtain this information.

**Note:** REOZMD/ROZMC (Mitsubishi engines) have an ECM but do not send signals to the generator set controller.

**Note:** See the generator set specification sheet for engine model identification.

### Controller Specifications

- Power source with circuit protection: 12- or 24-volt DC
- Power drain: 200 milliamps at 12 VDC or 100 milliamps at 24 VDC
- Humidity range: 5% to 95% noncondensing
- Operating temperature range: -40°C to +70°C (-40°F to +158°F)
- Storage temperature range: -40°C to +85°C (-40°F to +185°F)
- Standards:
  - CE Directive
  - NFPA 99
  - NFPA 110, Level 1
  - CSA 282-09
  - UL 508
  - ASTM B117 (salt spray test)
- Panel dimensions—W x H, 229 x 160 mm (9.0 x 6.3 in.)

### Communication and PC Software Available Options

Refer to G6-76 Monitor III Software and the communication literature for additional communication and PC software information including Modbus® communication.

- Monitor III Software for Monitoring and Control (Windows®-based user interface)**
- Converter, Modbus®/Ethernet.** Supports a power system using controllers accessed via the Ethernet. Converter is supplied with an IP address by the site administrator. Refer to G6-79 for converter details.
- Converter, RS-232/RS-485.** Supports a power system using controllers accessed via a serial (RS-232) connection.

### APM402 Available Options

- Float/Equalize Battery Charger** available with 6 or 10 amp output for 12 or 24V DC voltage output. The 10 amp model provides NFPA 110 charging and alarming capability.
- Manual Speed Adjust** available for applications using closed transition ATS. Adjustment range for 60 Hz: 1751- 1849 rpm (58.2- 61.8 Hz) and for 50 Hz: 1451- 1549 rpm (48.2- 51.8 Hz).
- Prime Power Switch** prevents battery drain during generator set non-operation periods and when the generator set battery cannot be maintained by an AC battery charger.
- Remote Emergency Stop Switch** available as a wall mounted panel to remotely shut down the generator set.
- Remote Monitoring Panel.** The Kohler® Remote Serial Annunciator (RSA) enables the operator to monitor the status of the generator set from a remote location, which may be required for NFPA 99 and NFPA 110 installations, and up to four Automatic transfer switches.
- Run Relay** provides a relay indicating that the generator set is running.
- Shunt Trip Wiring** provides relay outputs to trip a shunt trip circuit breaker and to signal the common fault shutdowns. Contacts rated at 10 amps at 28 VDC or 120 VAC.
- Two Input/Five Output Module** provides a generator set mounted panel with two inputs and five relay outputs.

Windows® is a registered trademark of Microsoft Corporation.  
 Modbus® is a registered trademark of Schneider Electric.

**DISTRIBUTED BY:**

Availability is subject to change without notice. Kohler Co. reserves the right to change the design or specifications without notice and without any obligation or liability whatsoever. Contact your local Kohler® generator set distributor for availability.

© 2018 Kohler Co., All rights reserved.

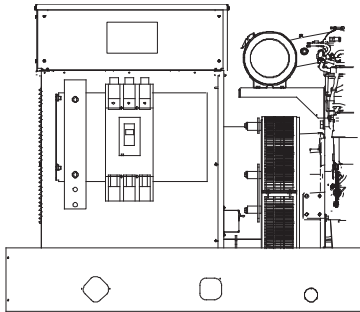

**Single Circuit Breaker Kit with Neutral Bus Bar 15-300 kW Model Shown**

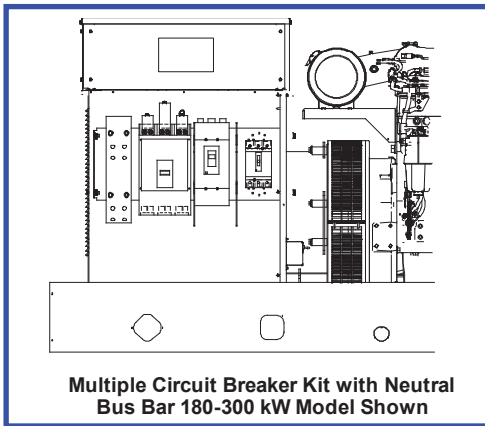

**Multiple Circuit Breaker Kit with Neutral Bus Bar 180-300 kW Model Shown**

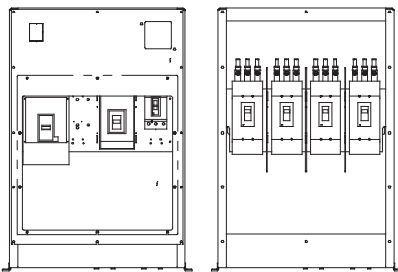

**Multiple Circuit Breaker Kits with Neutral Bus Bar 350-2250 kW Model Shown (also applies to some 300 kW models)**

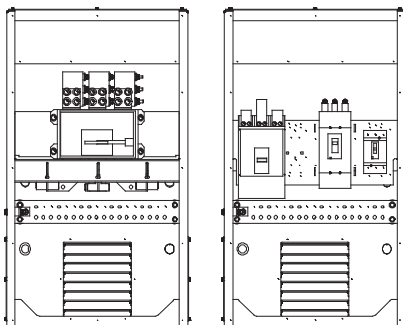

**Circuit Breaker Kits with Neutral Bus Bar 700-2500 kW KD Model Shown**

#### Standard Features

- The line circuit breaker interrupts the generator set output during a short circuit and protects the wiring when an overload occurs. Use the circuit breaker to manually disconnect the generator set from the load during generator set service.
- Circuit breaker kits are mounted to the generator set and are provided with load-side lugs and neutral bus bar.
- Kohler Co. offers a wide selection of molded-case line circuit breaker kits including single, dual, and multiple configurations for each generator set.
- Four types of line circuit breakers are available: (see page 2 for definitions and pages 3 and 4 for application details)
  - Magnetic trip
  - Thermal magnetic trip
  - **Electronic trip**
  - Electronic with ground fault (LSIG) trip
- In addition, line circuit breakers are offered with 80% and 100% ratings.
- Single line circuit breaker kits allow circuit protection of the entire electrical system load.
- Dual line circuit breaker kits allow circuit protection of selected priority loads from the remaining electrical system load.
- Multiple line circuit breaker kits with field connection barrier allow circuit protection for special applications (350-2500 kW models and selected 80-300 kW models).
- Up to four line circuit breakers can be used on 350-2500 kW models.
- Line circuit breakers comply with the following codes and standards unless otherwise stated.
  - UL 489 Molded Case Circuit Breakers
  - UL 1077 Supplementary Protectors
  - UL 2200 Stationary Engine Generator Assemblies

## Line Circuit Breaker Types

### Magnetic Trip

The magnetic trip features an electromagnet in series with the load contacts and a moveable armature to activate the trip mechanism. When a sudden and excessive current such as a short circuit occurs, the electromagnet attracts the armature resulting in an instantaneous trip.

### Thermal Magnetic Trip

Thermal magnetic trip contains a thermal portion with a bimetallic strip that reacts to the heat produced from the load current. Excessive current causes it to bend sufficiently to trip the mechanism. The trip delay is dependent on the duration and excess of the overload current. Elements are factory-calibrated. A combination of both thermal and magnetic features allows a delayed trip on an overload and an instantaneous trip on a short circuit condition.

### Electronic Trip

These line circuit breakers use electronic controls and miniature current transformers to monitor electrical currents and trip when preset limits are exceeded.

LI breakers are a combination of adjustable trip functions including long-time ampere rating, long-time delay, and instantaneous pickup. LSI breakers have all of the LI breaker features plus short-time pickup, short-time delay, and defeatable instantaneous pickup. LSI breakers have all of the LSI breaker features plus ground-fault pickup and delay.

**NOTE:** MG-frame does not have a long-time delay when selected with LI breakers.

### Electronic with Ground Fault Trip

The ground fault trip feature is referred to as LSI in this document. Models with LSI compare current flow in phase and neutral lines, and trip when current unbalance exists.

Ground fault trip units are an integral part of the circuit breaker and are not available as field-installable kits. The ground fault pickup switch sets the current level at which the circuit breaker will trip after the ground fault delay. Ground fault pickup values are based on circuit breaker sensor plug only and not on the rating plug multiplier. Changing the rating plug multiplier has no effect on the ground fault pickup values.

### 80% Rated Circuit Breaker

Most molded-case circuit breakers are 80% rated devices. An 80% rated circuit breaker can only be applied at 80% of its rating for continuous loads as defined by NFPA 70. Circuit conductors used with 80% rated circuit breakers are required to be rated for 100% of the circuit breaker's rating.

The 80% rated circuit breakers are typically at a lower cost than the 100% rated circuit breaker but load growth is limited.

### 100% Rated Circuit Breaker

Applications where all UL and NEC restrictions are met can use 100% rated circuit breakers where 100% rated circuits can carry 100% of the circuit breaker and conductor current rating.

The 100% rated circuit breakers are typically at a higher cost than the 80% rated circuit breaker but have load growth possibilities.

When applying 100% rated circuit breakers, comply with the various restrictions including UL Standard 489 and NEC Section 210. If any of the 100% rated circuit breaker restrictions are not met, the circuit breaker becomes an 80% rated circuit breaker.

## Line Circuit Breaker Options

### ❑ Alarm Switch

The alarm switch indicates that the circuit breaker is in a tripped position caused by an overload, short circuit, ground fault, the operation of the shunt trip, an undervoltage trip, or the push-to-trip pushbutton. The alarm resets when the circuit breaker is reset.

### ❑ Auxiliary Contacts

These switches send a signal indicating whether the main circuit breaker contacts are in the open or closed position.

### ❑ Breaker Separators (350-2500 kW)

Provides adequate clearance between breaker circuits.

### ❑ Bus Bars

Bus bar kits offer a convenient way to connect load leads to the generator set when a circuit breaker is not present. **15-300 kW.** Bus bar kits are available on alternators with leads for connection to the generator set when circuit breakers are not ordered.

**350-2500 kW.** A bus bar kit is provided when no circuit breaker is ordered. Bus bars are also available in combination with circuit breakers or other bus bars on the opposite side of the junction box. On medium voltage (3.3 kV and above) units, a bus bar kit is standard (not applicable to KD models).

### ❑ Field Connection Barrier

Provides installer wiring isolation from factory connections.

### ❑ Ground Fault Annunciation

A relay contact for customer connection indicates a ground fault condition and is part of a ground fault alarm.

### ❑ Lockout Device (padlock attachment)

This field-installable handle padlock attachment is available for manually operated circuit breakers. The attachment can accommodate three padlocks and will lock the circuit breaker in the OFF position only.

### ❑ Lugs

Various lug sizes are available to accommodate multiple cable sizes for connection to the neutral or bus bar.

### ❑ Overcurrent Trip Switch

The overcurrent trip switch indicates that the circuit breaker has tripped due to overload, ground fault, or short circuit and returns to the deenergized state when the circuit breaker is reset.

### ❑ Shunt Trip, 12 VDC or 24 VDC

A shunt trip option provides a solenoid within the circuit breaker case that, when momentarily energized from a remote source, activates the trip mechanism. This feature allows the circuit breaker to be tripped by customer-selected faults such as alternator overload or overspeed. The circuit breaker must be reset locally after being tripped. Tripping has priority over manual or motor operator closing.

### ❑ Shunt Trip Wiring

Connects the shunt trip to the generator set controller. (standard on KD models with the APM802 controller)

### ❑ Undervoltage Trip, 12 VDC or 24 VDC

The undervoltage trips the circuit breaker when the control voltage drops below the preset threshold of 35%- 70% of the rated voltage.

## 15-300\* kW Line Circuit Breaker Specifications

\* Includes models 300REOZJ and 300REZXC. For other 300 kW models, see the 350-2250 kW section.

### 80% Rating Circuit Breaker

Alt. Model	Ampere Range	Trip Type	C. B. Frame Size
4D/4E	15-150	Thermal magnetic	HD
	60-150	Electronic LSI	
	60-150	Electronic LSI	HG
4P/4PX/ 4Q/4QX	15-150	Thermal magnetic	HD
	60-150	Electronic LSI	
	60-150	Electronic LSI	HG
	175-250	Thermal magnetic	JD
	250	Electronic LSI	
	250	Electronic LSI	JG
	300-400	Thermal magnetic	LA
	400	Electronic LSI	LG

Alt. Model	Ampere Range	Trip Type	C. B. Frame Size
4RX 4S/4SX 4TX/4V 4UA 4M6226	15-150	Thermal magnetic	HD
	60-150	Electronic LSI	
	60-150	Electronic LSI	HG
	175-250	Thermal magnetic	JD
	250	Electronic LSI	
	250	Electronic LSI	JG
	300-400	Thermal magnetic	LA
	400-600	Electronic LSI	LG
	800	Electronic LSI	PG
	4UA 4M6226	1000-1200	Thermal magnetic
Electronic LSI			
1200		Thermal Magnetic	PJ
		Electronic LSI	

## 15-300\* kW Line Circuit Breaker Specifications

\* Includes models 300REOZJ and 300REZXC. For other 300 kW models, see the 300-2250 kW section.

### 100% Rating Circuit Breaker

Alt. Model	Ampere Range	Trip Type	C. B. Frame Size
4D/4E	15-150	Thermal magnetic	HD
	60-150	Electronic LSI	
	60-150	Electronic LSI	HG
4P/4PX 4Q/4QX	15-150	Thermal magnetic	HD
	60-150	Electronic LSI	
	60-150	Electronic LSI	HG
	175-250	Thermal magnetic	JD
	250	Electronic LSI	JD
	250	Electronic LSI	JG
	400	Electronic LSI	LG
4RX 4S/4SX 4TX 4V 4UA 4M6226	15-150	Thermal magnetic	HD
	60-150	Electronic LSI	
	60-150	Electronic LSI	HG
	175-250	Thermal magnetic	JD
	250	Electronic LSI	
	250	Electronic LSI	JG
	400	Electronic LSI	LG
600-800	Electronic LSI	PG	
4UA 4M6226	1000-1200	Electronic LSI	PG
	1200	Electronic LSI	PJ

### Interrupting Ratings

Circuit Breaker Frame Size	240 Volt, kA	480 Volt, kA	600 Volt, kA
HD	25	18	14
HG	65	35	18
HJ	100	65	25
JD	25	18	14
JG	65	35	18
JJ	100	65	25
LA	42	30	22
LG	65	35	18
MG			
PG	65	35	18
PJ	100	65	25
PL	125	100	25

### Circuit Breaker Lugs Per Phase (Al/Cu)

Frame Size	Ampere Range	Wire Range
H	15-150	One #14 to 3/0
J	175	One 1/0 to 4/0
	200-250	One 3/0 to 350 kcmil
LA	300-400	One #1 to 600 kcmil or Two #1 to 250 kcmil
LG	400-600	Two 2/0 to 500 kcmil AL/CU
M	800	Three 3/0 to 500 kcmil
P	600-800	Three 3/0 to 500 kcmil
	1000-1200	Four 3/0 to 500 kcmil
<b>Mechanical Load Lugs Included with H, J, and LG LSI/Neutral</b>		
H	60-150	One #14 to 3/0 AL/CU
J	250	One 3/0 to 350 kcmil AL/CU
LG	400-600	Two 4/0 to 500 kcmil AL/CU

### 100% Rating Electrically Operated Breakers

For use as paralleling breakers with the Decision-Maker® 6000 Controller/DPS System or APM603 controller.

Generator-Mounted P-Frame, 24VDC Electrically			
Alt. Model	Amps	Trip Unit	Frame
4RX 4S/4SX 4TX 4V	250	5.0 LSI	PJ
	400		
	600	5.0 LSI	PL
	800		
4UA 4M6226	250	5.0 LSI	PJ
	400		
	600		
	800	5.0 LSI	PL
	1000		
1200			

All circuit breakers listed in this table include line side bus and load side lugs, 24VDC motor operators, 2 type C auxiliary contacts, and 1 type C SDE overcurrent switch contact. No second breakers are allowed in combination with



KOHLER CO., Kohler, Wisconsin 53044 USA  
Phone 920-457-4441, Fax 920-459-1646  
For the nearest sales and service outlet in  
the US and Canada, phone 1-800-544-2444  
KOHLERPower.com

---

Availability is subject to change without notice. Kohler Co. reserves the right to change the design or specifications without notice and without any obligation or liability whatsoever. Contact your local Kohler® generator set distributor for availability.

**DISTRIBUTED BY:**

© 2007 Kohler Co. All rights reserved.

# PowerPact™ H-, J-, and L-Frame Circuit Breakers Trip Curves

Figure 96: Micrologic 3.3S and 3.3S-W Electronic Trip Unit Long Time/Short Time Trip Curve

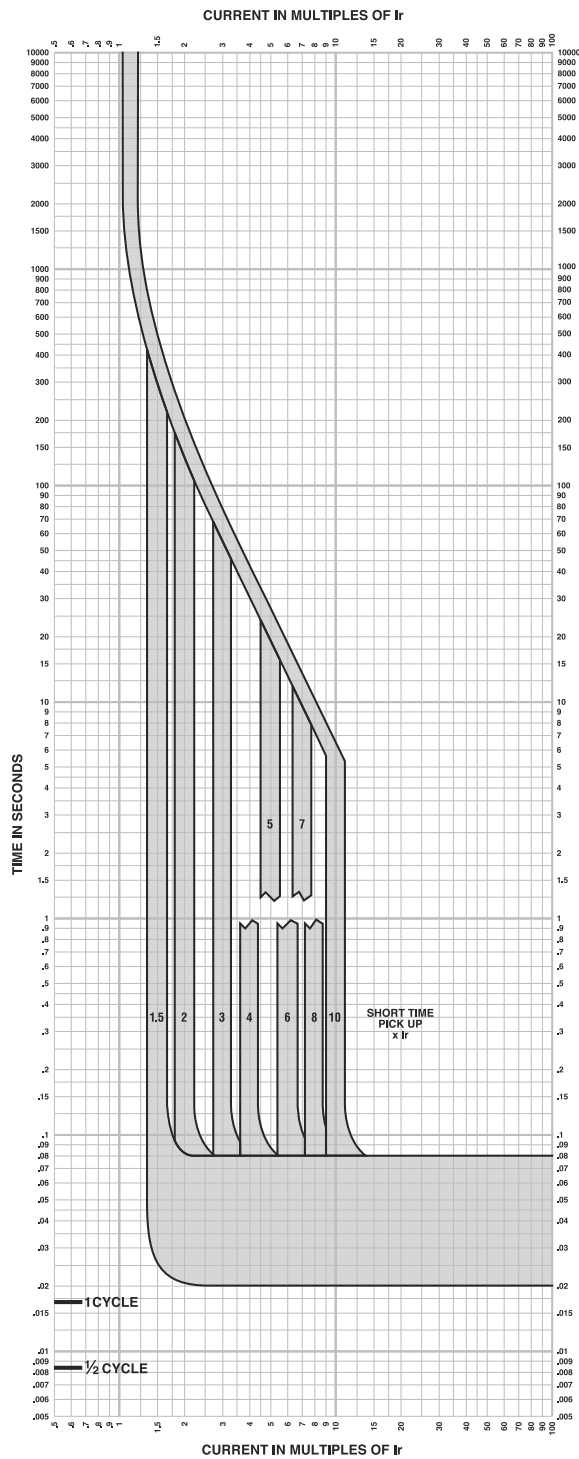

## MICROLOGIC™ ELECTRONIC TRIP UNITS Micrologic™ 3.3S and 3.3S-W Long Time/Short Time Trip Curve 250A, 400A L-Frame

The time-current curve information is to be used for application and coordination purposes only.

### Notes:

1. There is a thermal-imaging effect that can act to shorten the long-time delay. The thermal imaging effect comes into play if a current above the long-time delay pickup value exists for a time and then is cleared by the tripping of a downstream device or the circuit breaker itself. A subsequent overload will cause the circuit breaker to trip in a shorter time than normal. The amount of time delay reduction is inverse to the amount of time that has elapsed since the previous overload. Approximately 20 minutes is required between overloads to completely reset thermal-imaging.
2. Total clearing times shown include the response times of the trip unit, the circuit breaker opening, and the extinction of the current.

Curves apply from -35°C to +70°C (-31°F to +158°F) ambient temperature.



Typical Overall Dimensions

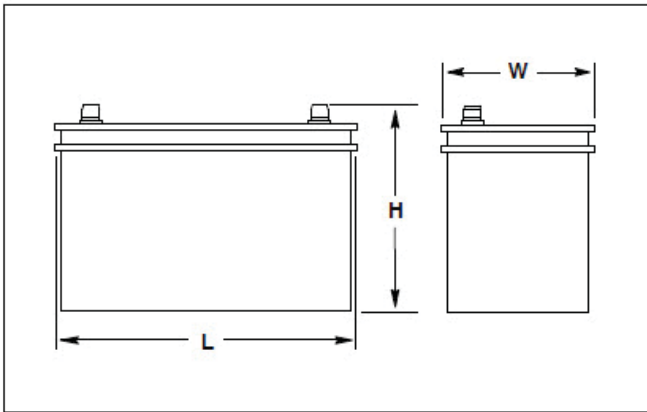

Standard Features

- Kohler Co. selects batteries to meet the engine manufacturer's specifications and to comply with NFPA requirements for engine-cranking cycles.
- Heavy-duty starting batteries are the most cost-effective means of engine cranking and provide excellent reliability in generator set applications.
- Tough polypropylene cases protect against life-shortening vibration and impact damage.
- Batteries are rated according to SAE standard J-537.
- All batteries are 12-volts. Kits that contain two or four batteries are available for 24-volt systems and/or systems with redundant starters.
- Wet- and dry-charged batteries have lead-calcium or lead-antimony plates and use sulfuric acid electrolyte. Removable cell covers allow checking of electrolyte specific gravity.
- Absorbant glass mat (AGM) batteries are sealed and maintenance free.
- Batteries are for applications below and above 0°C (32°F).

Charge Type*	Battery Part Number	Battery Qty. per Size	BCI Group Size	Battery SAE Dimension, mm (in.)			Cold Cranking Amps at 18°C (0°F) Min.	Reserve Capacity Minutes at 27° (80°F) Min.	Battery Post Layout and Style
				L	W	H			
Wet	324586	2	31	330.2 (13.0)	173.0 (6.8)	239.8 (9.4)	950	185	C/3

Battery Specifications

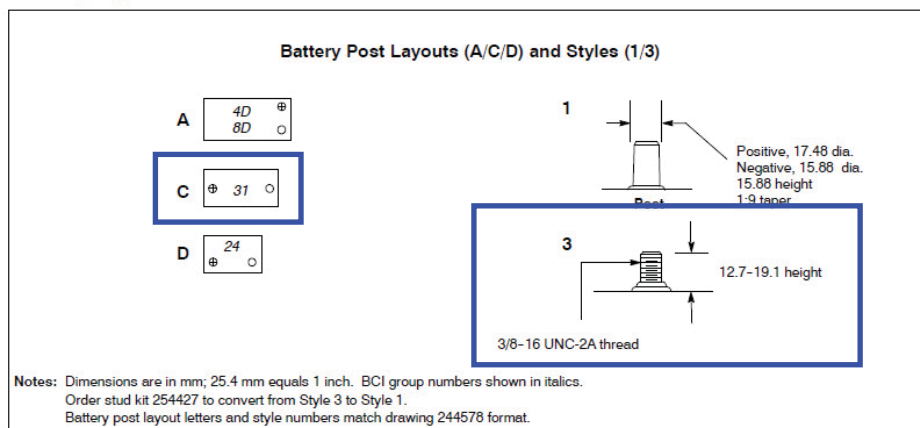

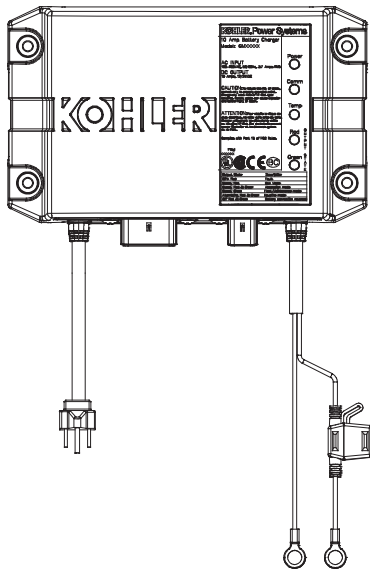

The battery charger is a fully-automatic, high efficiency battery charger that charges batteries rapidly and safely. The battery charger is designed for an industrial environment.

The battery charger is designed for operation with an engine cranking battery.

The battery charger is universal voltage input capable, comes with a standard 120 V/60 Hz AC plug, and charges 12 VDC or 24 VDC battery systems.

Five LED lights indicate power, communication status, temperature compensation status, charge curve, and charger status.

With the optional battery temperature sensor connected, the battery charger can adjust output voltages for optimal charging.

### Standard Features

- 12 or 24 VDC output
  - Automatic voltage detection
- Automatic multi-stage charging modes
  - Recovery charge
  - Bulk charge
  - Absorption charge
  - Float charge
  - Equalize charge
- Charges the following type batteries:
  - Flooded lead acid (FLA)
  - AGM
  - Gel cell
  - High performance AGM
  - Nickel-cadmium (NiCad)
- 5 LED status indicators
- Durable potted assembly for waterproofing and vibration resistance
- Reverse-polarity protection
- Short-circuit protection
- Electronically limited output current
- Optional temperature compensation (FLA only)
- User adjustable parameters to support optimal manufacturer recommended charge curve.
- Code compliance:
  - UL 1236 Listed
  - NFPA 110, Level 1 compatible (when used with Kohler controller and connected to engine harness)
  - CSA - C22.2 No. 107.2-01
  - FCC - Title 47, Part 15 Class A
  - CE
  - IBC 2015
  - OSHPD

DC Output		AC Input		Overall Dimensions W x D x H	Shipping Weight	
Volts (Nominal)	Amps	Volts (Nominal)	Amps		kgs	lbs
12/24	10	100-260	3.7	253 mm x 152 mm x 74 mm (10.0 in x 6.0 in x 2.9 in)	3.6	7.9

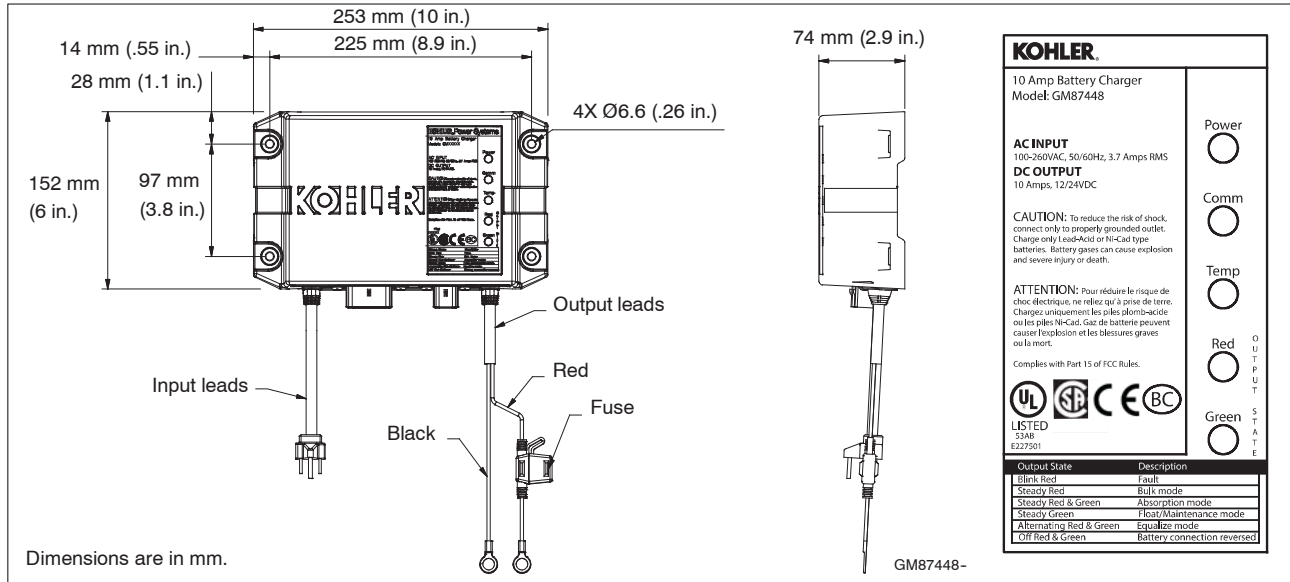

## Specifications

<b>AC Input</b>	100-260 VAC
<b>Frequency Input</b>	50/60 Hz
<b>DC Output</b>	10 Amps @ 12 VDC or 10 Amps @ 24 VDC (On battery voltage regulation ±1%; current is electronically limited)
<b>Fuse Protection</b>	15 amps ATC
<b>Battery Types</b>	Flooded Lead Acid (FLA) AGM Gel Cell High Performance AGM Nickel-Cadmium (NiCad)
<b>Monitoring</b> LED Indications	Power Communication Temperature compensation Output charger curve and charger status: <ul style="list-style-type: none"> <li>○ Red</li> <li>○ Green</li> </ul>
<b>Environmental</b>	
Operating	-20° to 70°C (-4° to 158° F)
Storage	-40° to 85°C (-40° to 185° F)
Relative Humidity	5 to 95% (non-condensing)
Salt Spray Testing	ASTM B117
Corrosion Resistant	From battery gases

<b>Enclosure</b>	
Environmental Resistant	From rain, snow, dust, and dripping water
<b>Battery Connections</b>	
Lead Length	1.8 m (6 ft.) red and black leads
Battery Connections	9.5 mm (3/8 in.) ring terminals
<b>AC Power Connections</b>	
Lead Length	1.8 m (6 ft.)
Storage	Standard US style 3-prong AC plug
<b>Available Options</b>	
Temperature compensation	

### DISTRIBUTED BY:

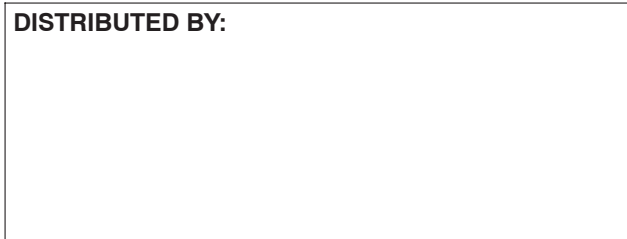

Availability is subject to change without notice. Kohler Co. reserves the right to change the design or specifications without notice and without any obligation or liability whatsoever. Contact your local Kohler® generator distributor for availability.

© 2017, 2019 by Kohler Co. All rights reserved.

**ISO 9001**  
**KOHLER**  
 POWER SYSTEMS  
 NATIONALLY REGISTERED

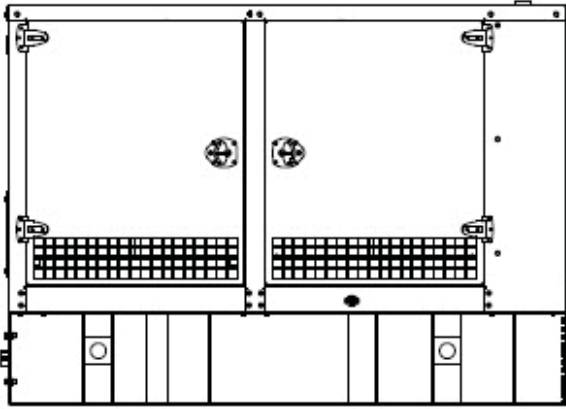

**Enclosure with Standard Subbase Fuel Tank**

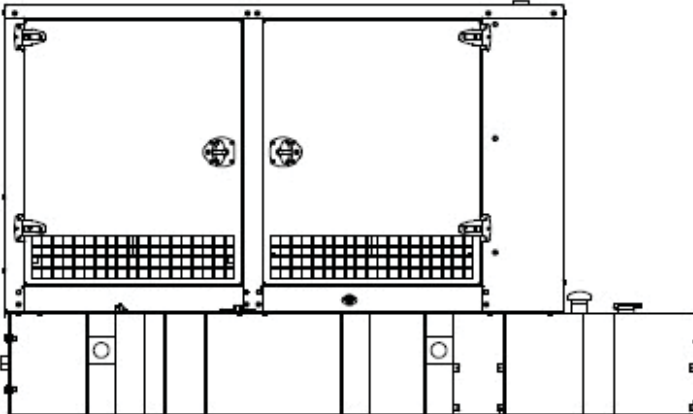

**Enclosure with State Code Subbase Fuel Tank**

### Sound Enclosure Standard Features

- Internal-mounted critical silencer and flexible exhaust connector.
- Lift base-mounted or tank mounted aluminum construction with hinged doors. Aluminum enclosures are recommended for high humidity and/or high salt/coastal regions
- Fade-, scratch-, and corrosion-resistant Kohler® Power Armor automotive-grade textured finish.
- Power Armor surpasses 3,000-hour salt spray corrosion tests per ASTM B- 1117
- Enclosure has four access doors which allow for easy maintenance.
- Lockable, flush-mounted door latches.
- Vertical air inlet and outlet discharge to redirect air and reduce noise.
- Acoustic insulation that meets UL 94 HF1 flammability classification and repels moisture adsorption.
- Sound-attenuated that uses up to 51 mm (2 in.) of acoustic insulation.
- Aluminum sound enclosure is certified to 181 mph (291 kph) wind load rating for 180-300REOZJ models.

### Subbase Fuel Tank Features

- The fuel tank has a Power Armor Plus textured epoxy-based rubberized coating.
- The above-ground rectangular secondary containment tank mounts directly to the generator set, below the generator set skid (subbase).
- Both the inner and outer tanks have emergency relief vents.
- Flexible fuel lines are provided with subbase fuel tank selection.
- The secondary containment generator set base tank meets UL 142 tank requirements. The inner (primary) tank is sealed inside the outer (secondary) tank. The outer tank contains the fuel if the inner tank leaks or ruptures.

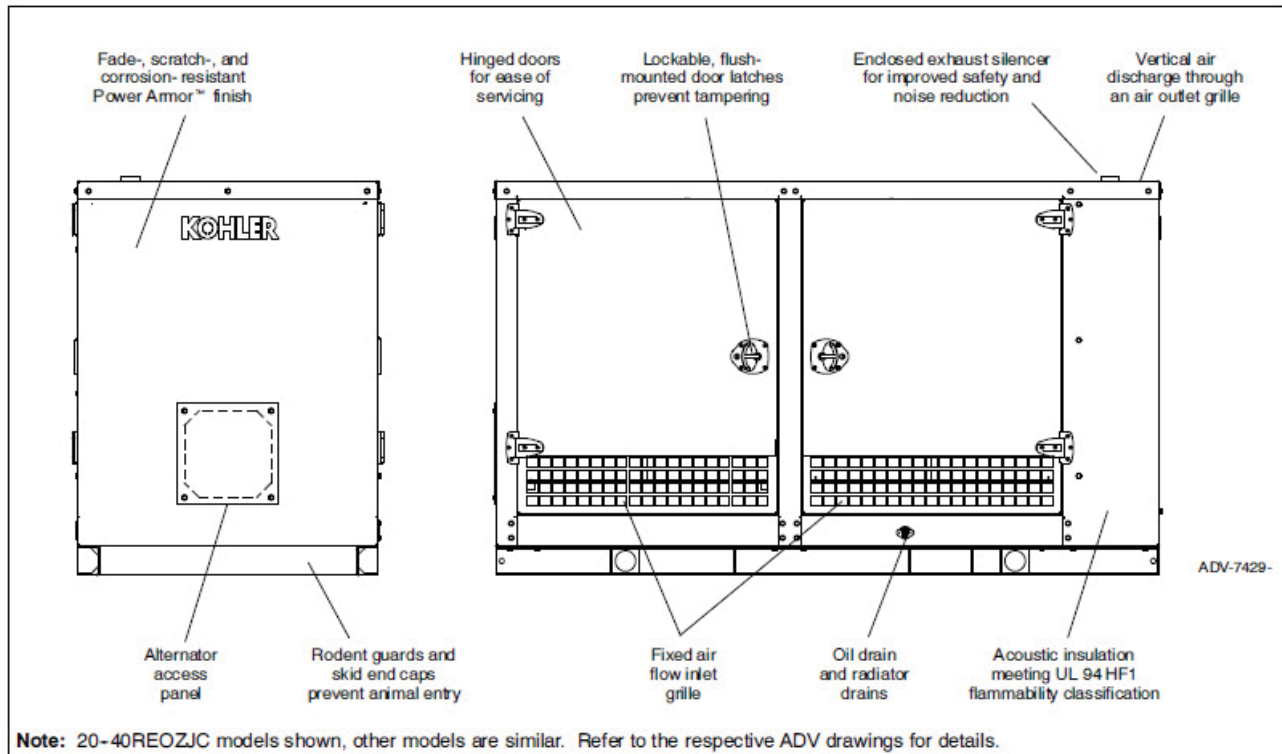

## Sound Enclosure Features

- Available in aluminum 3.2mm (0.125 in.) formed panel, solid construction. Preassembled package offering corrosion resistant, dent resilient structure mounting directly to lift base or fuel tank.
- Power Armor automotive-grade finish resulting in advanced corrosion and abrasion protection as well as enhanced edge coverage and color retention.
- Internal exhaust silencer offering maximum component life and operator safety.
- Interchangeable modular panel construction. Allows complete serviceability or replacement without compromising enclosure design.
- Cooling/combustion air intake with a horizontal air inlet. Sized for maximum cooling airflow.
- Service access. Multi-personnel doors for easy access to generator set control and servicing of the fuel fill, fuel gauge, oil fill and battery.
- Cooling air discharge. Weather protective design featuring vertical air discharge. Redirects cooling air up and above the enclosure to reduce ambient noise.
- Attenuated design. Acoustic insulation UL 94 HF1 listed for flame resistance offering up to 51 mm (2 in.) mechanically restrained acoustic insulation.
- Cooling air discharge. The sound enclosures include acoustic insulation with urethane film.
- Note: Installing an additional length of exhaust tail pipe may increase backpressure levels. Please refer to the generator set spec sheet for the maximum backpressure value.

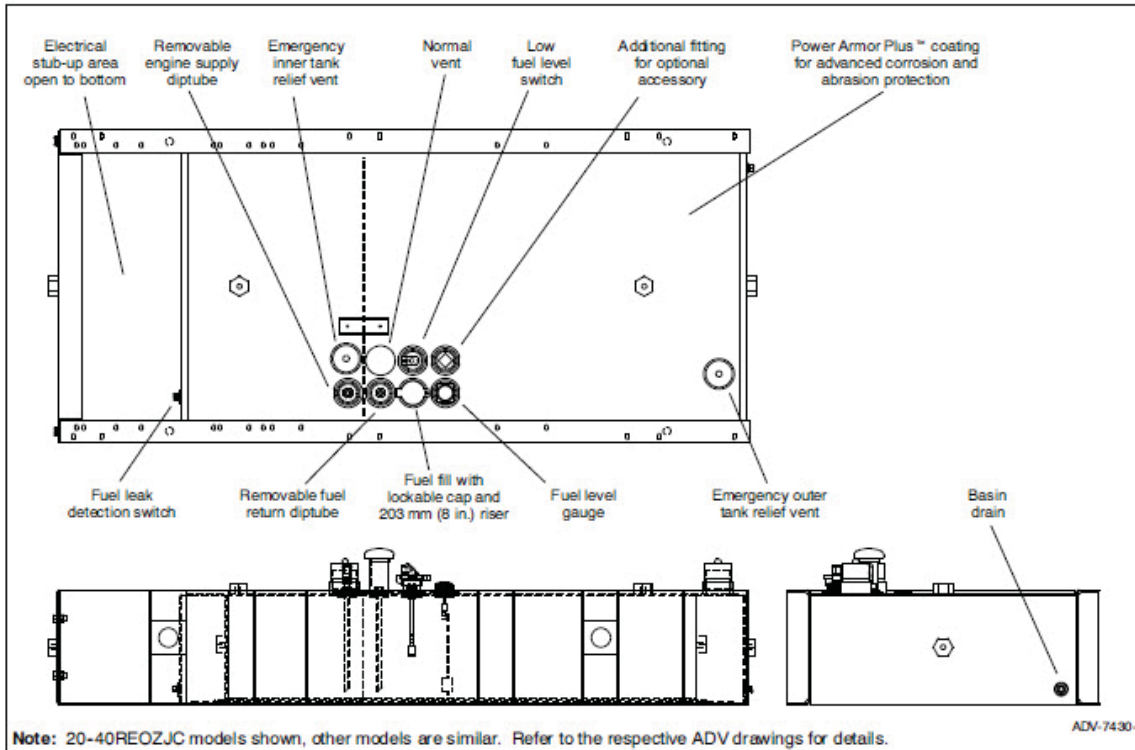

- Extended operation. Usable tank capacities offers full load standby operation of up to 72 hours.
- Power Armor Plus textured epoxy-based rubberized coating that creates an ultra-thick barrier between the tank and harsh environmental conditions like humidity, saltwater, and extreme temperatures, and provides advanced corrosion and abrasion protection.
- UL listed. Secondary containment generator set base tank meeting UL 142 tank requirements.
- NFPA compliant. Designed to comply with the installation standards of NFPA 30 and NFPA 37.
- Integral external lift lugs. Enables crane with spreader-bar lifting of the complete package (empty tank, mounted generator set, and enclosure) to ensure safety.
- Emergency pressure relief vents. Meets UL requirements; ensures adequate venting of inner and outer tank under extreme pressure and/or emergency conditions.
- Normal vent with cap. Vent is raised above lockable fuel fill.
- Low fuel level switch. Annunciates a 50% low fuel level condition at generator set control.
- Leak detection switch. Annunciates a contained primary tank fuel leak condition at generator set control.
- Electrical stub-up.

Fuel Tank Capacity, L (gal.)	Est. Fuel Supply Hours at 60 Hz with Full Load	Enclosure and Fuel Tank Length, mm (in.)	Enclosure and Fuel Tank Width, mm (in.)	Enclosure and Fuel Tank Weight, kg (lb.)	Enclosure and Fuel Tank Height, mm (in.)	Fuel Tank Height (H), mm (in.)	Sound Pressure Level, dB(A)
Lift base	0	4094 (161.2)	1338 (52.7)	1780 (3925)	2057 (81)	0 (0)	72
1514 (400)	24/31	4094 (161.2)	1338 (52.7)	2861 (6307)	2521 (99.3)	483 (19)	72

Note: Data in table is for reference only, refer to the respective ADV drawings for details.

Note: Refer to TIB-114 for generator set sound data.

Max. weight includes the generator set (wet), enclosure, silencer, and tank (no fuel). The generator set weight represents using the largest alternator option. The enclosure weight is with acoustic insulation added.

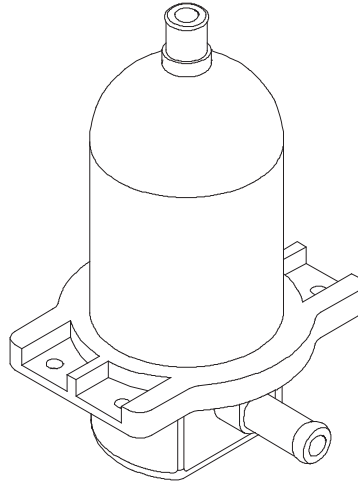

Block Heater Kit, typical

### Applicable Models

- KG40-KG125
- KG150-KG200
- KG150R
- 25-45REZG
- 25-60REZGB
- 50REZGC/125REZGC/150REZGC
- 50-60REOZJD
- 50REOZJE
- 80REZGD/100REZGD
- 80RZGD/100RZGD
- 80-200REOZJF
- 80-150REOZJG4
- 125RZGC/150RZGC
- **125REOZJG/180REOZJG**

### Standard Features

- UL-C/US listed
- CE compliant
- Controls for automatic operation
- Compact design
- Easy to install

### Description

The engine block heater kit heats the engine coolant in cold ambient, warming the cylinders, oil, and charge air circuit which all help to give a faster starting time. The engine block heater uses thermosiphon action to circulate warm coolant into the engine and supplies constant heating to the engine. The engine block heater kit helps to extend element life and gives a significant reduction in electrical consumption.

The engine block heater kit is recommended for ambient temperatures below 10°C (50°F).

The engine block heater kits are available in 120 V, 240 V, and 277 V versions.

## Block Heater Specifications

Heating Fluid	Water, Coolant Mix (50% Glycol/50% Water)
Max. Pressure	90 psi (620 kPa)
Heating Element Material	Incoloy 800
Inlet/Outlet Plumbing	0.625 in. hose barb
System Ingress	IP41
Power Connection	<b>NEMA Plug</b> and EURO Plug
Power Chord Length	48 in. (1219 mm)

## Specifications

Block Heater Kit Number	Component	Watts	Voltage	Phase	Thermostat Temperature	
					ON	OFF
GM58098-KA1	358311	1000	120	1	27°C (80°F)	38°C (100°F)
GM75536-KA1	326228	1500	120	1	49°C (120°F)	60°C (140°F)
<b>GM75555-KA5</b>	<b>GM75552</b>	<b>1800</b>	<b>120</b>	<b>1</b>	<b>27°C (80°F)</b>	<b>38°C (100°F)</b>
GM75555-KA6	GM75553	2000	240	1		
GM75556-KA1	352945	1500	120	1		
GM75557-KA1	352945	1500	120	1		
GM75564-KA1	358311	1000	120	1		
GM75565-KA1	352945	1500	120	1		
GM77944-KA1	352945	1500	120	1		
GM77944-KA2	352946	1500	240	1		
GM85060-KA1	GM75552	1800	120	1		
GM85060-KA2	GM75553	2000	240	1		
GM89427-KA2	GM75552	1800	120	1		
GM91708-KA1	352945	1500	120	1		
GM94248-KA1	352945	1500	120	1		
GM104799-KA1	352945	1500	120	1		
GM105165-KA1	352945	1500	120	1		
GM105165-KA2	352946	1500	240	1		
GM105409-KA1	352945	1500	120	1		
GM105409-KA2	352946	1500	240	1		
GM115370-KA1	352945	1500	120	1		
GM115370-KA2	352946	1500	240	1		

## Dimensions and Weights

Overall Size, H x W, mm (in): 199 x 122 (7.8 x 4.8)  
Weight, kg (lb): 0.77 (1.7)

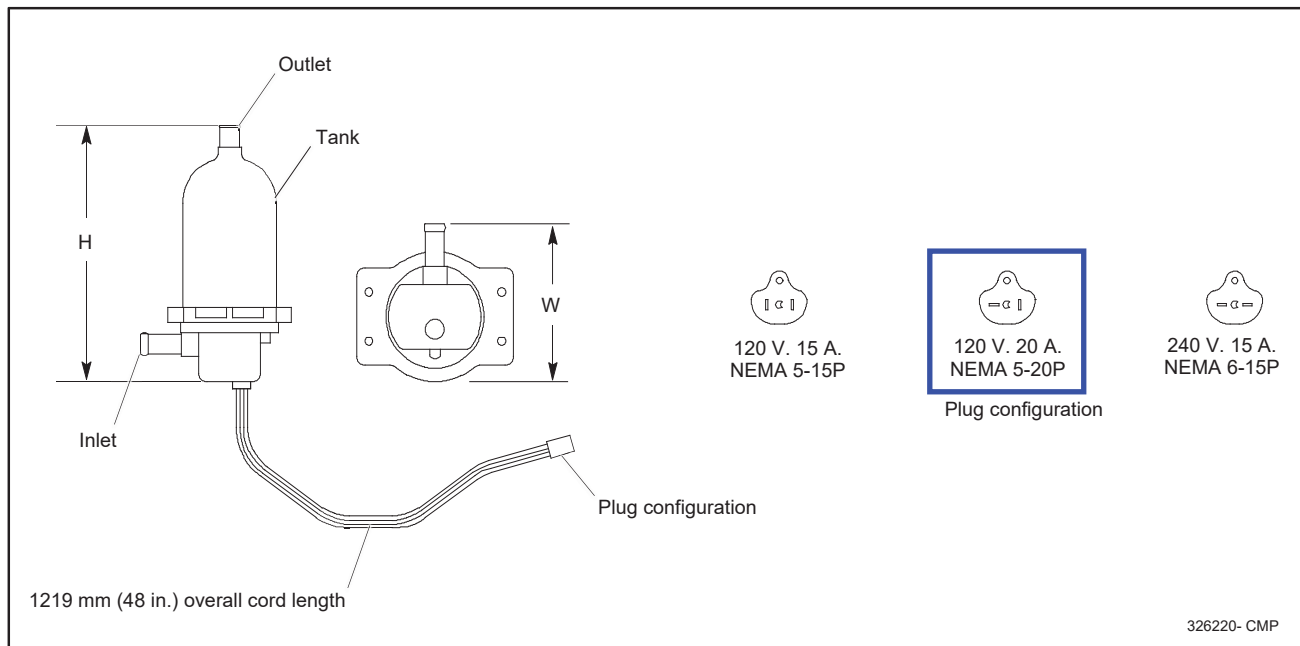



KOHLER CO., Kohler, Wisconsin 53044 USA  
Phone 920-457-4441, Fax 920-459-1646  
For the nearest sales and service outlet in  
the US and Canada, phone 1-800-544-2444  
KOHLERPower.com

---

Availability is subject to change without notice. Kohler Co. reserves the right to change the design or specifications without notice and without any obligation or liability whatsoever. Contact your local Kohler® generator distributor for availability.

<b>DISTRIBUTED BY:</b>
------------------------

© 2020 Kohler Co. All rights reserved.

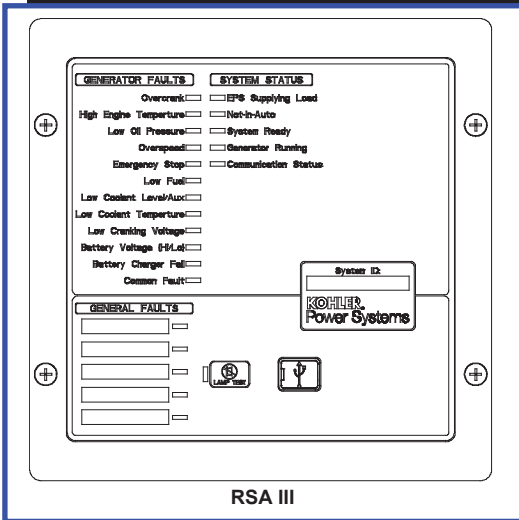

RSA III

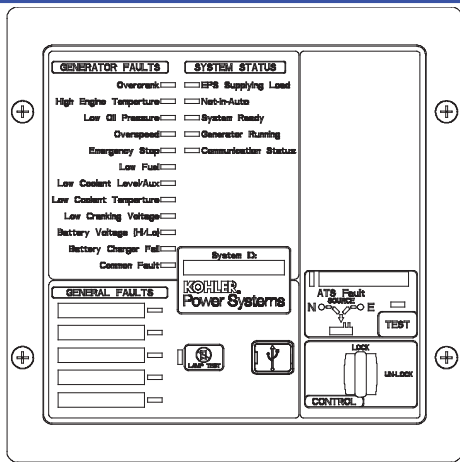

RSA III with a Single ATS Control

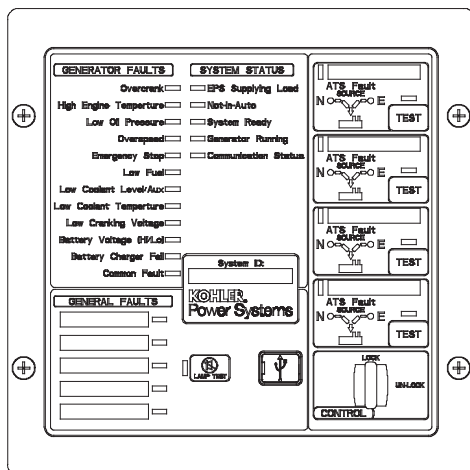

RSA III with Four ATS Controls

### Remote Serial Annunciator III (RSA III) for Kohler® Controllers

- Monitors the generator set equipped with one of the following controllers:
 

APM402	Decision-Maker® 3000
APM603	Decision-Maker® 3500
APM802	Decision-Maker® 6000
Decision-Maker® 3+	Decision-Maker® 8000
Decision-Maker® 550	KPC 1000
- Allows monitoring of the common alarm, remote testing of the automatic transfer switch, and monitoring of the normal/emergency source for up to four ATS with any of the following controllers:
 

Decision-Maker® MPAC® 750, 1200, and 1500
MPAC® 1000 and 1500
- Configuration via a personal computer (PC) software.
- Writable surfaces (white boxes in illustrations) for user-defined selections.
- Uses Modbus® RTU protocol.
- Controller connections:
  - RS-485 for serial bus network
  - USB port. Connect a personal computer and use Kohler® SiteTech™ software to view events and adjust settings. \*
  - 12-/24-volt DC power supply
  - 120/208 VAC power supply (available accessory)
- Meets the National Fire Protection Association Standard NFPA 110, Level 1.

### Dimensions

- Dimensions—W x H x D, mm (in.).

#### Surface Mounted:

203 x 203 x 83 (8.0 x 8.0 x 3.3)

Flush Mounted (Inside Wall):  
203 x 203 x 76 (8.0 x 8.0 x 3.0)

Flush mounting plate W1: 254 (10.0)

\* SiteTech™ software is available to Kohler authorized distributors and dealers.

Modbus® is a registered trademark of Schneider Electric.

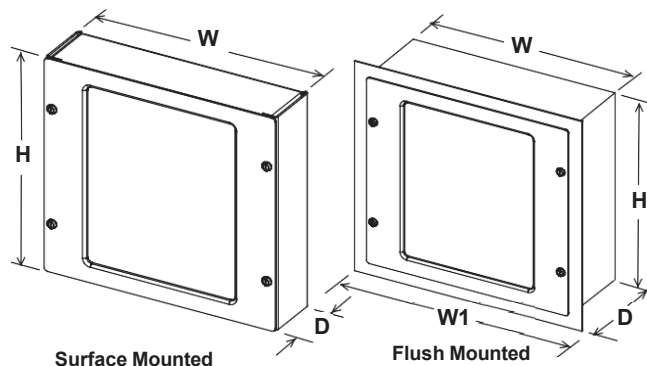

Fault and Status Conditions	Fault LEDs	Fault Horn	System Ready LED	Generator Running LED	Communication Status LED
Overcrank Shutdown	Red	On	Red	Off	Green
High Engine Temperature Warning *	Yellow	On	Red	Green	Green
High Engine Temperature Shutdown	Red	On	Red	Off	Green
Low Oil Pressure Warning *	Yellow	On	Red	Green	Green
Low Oil Pressure Shutdown	Red	On	Red	Off	Green
Overspeed Shutdown	Red	On	Red	Off	Green
Emergency Stop *	Red	On	Red	Off	Green
Low Coolant Level/Aux. Shutdown	Red	On	Red	Off	Green
Low Coolant Temperature *	Yellow	On	Red	Off	Green
Low Cranking Voltage	Yellow	On	Red	Off	Green
Low Fuel—Level or Pressure *	Yellow	On	Red	Green or Off	Green
Not-In-Auto	Red	On	Red	Green or Off	Green
Common Fault	Red/Yellow	On	Green	Green or Off	Green
Battery Charger Fault (1) *	Yellow	On	Red	Green or Off	Green
Battery Charger Fault (2) *	Yellow	On	Green	Green or Off	Green
High Battery Voltage *	Yellow	Off	Green	Green or Off	Green
Low Battery Voltage *	Yellow	Off	Green	Green or Off	Green
User Input #1 (Warning)	Yellow	Off	Green	Green or Off	Green
User Input #1 (Shutdown)	Red	On	Green	Off	Green
User Input #2 (Warning)	Yellow	Off	Green	Green or Off	Green
User Input #2 (Shutdown)	Red	On	Green	Off	Green
User Input #3 (Warning) (1) [	Yellow	Off	Green	Green or Off	Green
User Input #3 (Shutdown) (1) [	Red	On	Green	Off	Green
User Input #4 (Warning) (1)	Yellow	Off	Green	Green or Off	Green
User Input #4 (Shutdown) (1)	Red	On	Green	Off	Green
User Input #5 (Warning) (1)	Yellow	Off	Green	Green or Off	Green
User Input #5 (Shutdown) (1)	Red	On	Green	Off	Green
EPS Supplying Load	Yellow	Off	Green	Green	Green
Communications Status (Fault mode)	—	Off	Green or Red	Green or Off	Red
ATS Fault (RSA III with ATS Controls only)	Red	On	Red or Yellow	Green or Off	Green

Green LEDs appear as steady on when activated.  
Yellow (common warning) LEDs slow flash when activated except steady on with EPS supplying load and high battery voltage.  
Red (common fault) LEDs slow flash when activated except fast flash with loss of communication and not-in-auto.

## Specifications

- LED indicating lights for status, warning, and/or shutdown.
- Power source with circuit protection: 12- or 24-volt DC
- Power source with 120/208 VAC, 50/60 Hz adapter (option)
- Power draw: 200 mA
- Humidity range: 0% to 95% noncondensing
- Operating temperature range: -20°C to +70°C (-4°F to +158°F)
- Storage temperature range: -40°C to +85°C (-40°F to +185°F)
- Standards:
  - NFPA 110, level 1
  - UL 508 recognized
  - CE directive
  - NFPA 99
  - ENS 61000-4-4
  - EN611-4-4 fast transient immunity
- RS-485 Modbus® isolated port @ 9.6/19.2/38.4/57.6 kbps (default is 19.2 kbps)
- USB device port
- NEMA 1 enclosure
- (1) All generator set controllers except Decision-Maker® 3+ controller.
- (2) Decision-Maker® 3+ controller only.
- \* May require optional kit or user-provided device to enable function and LED indication.
- † Digital input #3 is factory-set for high battery voltage on the Decision-Maker® 3+ controller.

Modbus® is a registered trademark of Schneider Electric.

## ATS Controls (RSA III with ATS controls only)

- ATS position LED (normal or emergency)
- Power source indicator LED (normal or emergency)
- ATS fault LED
- Key-operated lock/unlock switch for Test feature
- Test pushbutton

## NFPA Requirements

- NFPA 110 compliant
- Engine functions:
  - High battery voltage warning \*
  - High engine temperature shutdown
  - High engine temperature warning \*
  - Low battery voltage warning \*
  - Low coolant level/aux. shutdown
  - Low coolant temperature warning \*
  - Low cranking voltage
  - Low fuel warning (level or pressure) \*
  - Low oil pressure shutdown
  - Low oil pressure warning \*
  - Overcrank shutdown
  - Overspeed shutdown
- General functions:
  - Audible alarm silence
  - Battery charger fault \*
  - Lamp test
  - Master switch not-in-auto

---

## Fault and Status LEDs and Lamp Test Switch

**Alarm Horn.** Horn sounds giving a minimum 90 dB at 0.1 m (0.3 ft.) audible alarm when a warning or shutdown fault condition exists except on high/low battery voltage or EPS supplying load.

**Alarm Silenced.** Red LED on lamp test switch lights when alarm horn is deactivated by alarm silence switch.

**Alarm Silence Switch.** Lamp test switch quiets the alarm during servicing. The horn will reactivate upon additional faults.

**ATS Fault.** Red LED lights when ATS fails to transfer.

**Battery Charger Fail.** LED lights if battery charger malfunctions. Requires battery charger with alarm contact.

**Battery Voltage Hi/Lo.** LED flashes if battery or charging voltage drops below preset level. LED lights steady if battery voltage exceeds preset level.

**Common Fault.** LED lights when a single or multiple common faults occur.

**Communication Status.** Green LED lights indicating annunciator communications functional. Red LED indicates communication fault.

**EPS Supplying Load.** LED lights when the Emergency Power System (EPS) generator set is supplying the load (APM402, APM603, APM802, and Decision-Maker® 550, 3000, 3500, 6000, and 8000 controllers) or when transfer switch is in the emergency position (Decision-Maker® 3+ controller).

**Emergency Stop.** LED lights and engine stops when emergency stop is made. May require a local emergency stop switch on some Decision-Maker® 3+ controllers.

**Generator Running.** LED lights when generator set is in operation.

**High Engine Temperature.** Red LED lights if engine has shut down because of high engine coolant temperature. Yellow LED lights if engine coolant temperature approaches shutdown range. Requires warning sender on some models.

**Lamp Test (Switch).** Switch tests all the annunciator indicator LEDs and horn.

**Low Coolant Level/Aux.** LED lights when engine coolant level is below acceptable range on radiator-mounted generator sets only. When used with a Decision-Maker® 3+ controller, the LED indicates low coolant level or an auxiliary fault shutdown. Requires user-supplied low coolant level switch on remote radiator models.

**Low Coolant Temperature.** LED lights if optional engine block heater malfunctions and/or engine coolant temperature is too low. Requires prealarm sender on some models.

**Low Cranking Voltage.** LED lights if battery voltage drops below preset level during engine cranking.

**Low Fuel (Level or Pressure).** LED lights if fuel level in tank approaches empty with diesel models or fuel pressure is low on gas models. Requires customer-supplied switch.

**Low Oil Pressure.** Red LED lights if generator set shuts down because of insufficient oil pressure. Yellow LED lights if engine oil pressure approaches shutdown range. Requires warning sender on some models.

**Not In Auto.** LED lights when the generator set controller is not set to automatic mode.

**Overcrank.** LED lights and cranking stops if engine does not start in either continuous cranking or cyclic cranking modes.

**Overspeed.** LED lights if generator set shuts down because of overspeed condition.

**System Ready.** Green LED lights when generator set master switch is in AUTO position and the system senses no faults. Red LED indicates system fault.

**User-Defined Digital Inputs #1- #5.** Monitors five digital auxiliary inputs (can be configured as warnings or shutdowns). User-defined digital inputs are selected via the RSA III master for local or remote (generator set or ATS). The user-defined digital input can be assigned via PC using SiteTech™ setup software.



KOHLER CO., Kohler, Wisconsin 53044 USA  
Phone 920-457-4441, Fax 920-459-1646  
For the nearest sales and service outlet in  
the US and Canada, phone 1-800-544-2444  
KOHLERPower.com

---

## Accessories

- Power source adapter kit 120/208 VAC, 50/60 Hz.
- Modbus<sup>®</sup>/Ethernet converter GM41143-KP2 for serial to Ethernet communication.
- Communication module GM32644-KA1 or GM32644-KP1 is required with Decision-Maker<sup>®</sup> 3+ controllers.

Modbus<sup>®</sup> is a registered trademark of Schneider Electric.

**DISTRIBUTED BY:**

Availability is subject to change without notice. Kohler Co. reserves the right to change the design or specifications without notice and without any obligation or liability whatsoever. Contact your local Kohler<sup>®</sup> generator set distributor for availability.

© 2014 by Kohler Co. All rights reserved.

**KOHLER®**

# Alternator Data

**TECHNICAL INFORMATION BULLETIN**

**Alternator Data Sheet**

Alternator Model: **4S12X**  
 Frequency: **60 Hz**  
 Speed: **1800 RPM**  
 Leads: **12 (6 Lead, 600 Volt)**

Voltage L-N/L-L	Phase	Power Factor	Connection	kW* (kVA)							
				Class B		Class F			Class H		
				80°C Continuous	90°C Lloyds	95°C ABS	105°C Continuous	130°C Standby	125°C Continuous	150°C Standby	
139/240 277/480	3	0.8	Wye	146.5 (183.0)	155.0 (193.5)	160.0 (200.0)	168.0 (210.0)	181.0 (226.0)	178.5 (223.0)	189.0 (236.0)	
127/220 254/440	3	0.8	Wye	136.0 (170.0)	143.0 (178.5)	146.5 (183.0)	152.5 (190.5)	164.0 (205.0)	162.0 (202.5)	171.5 (214.0)	
120/208 240/416	3	0.8	Wye	130.0 (162.5)	136.5 (170.5)	139.0 (173.5)	144.0 (180.0)	154.5 (193.0)	152.5 (190.5)	161.5 (201.5)	
110/190 220/380	3	0.8	Wye	118.5 (148.0)	124.5 (155.5)	126.5 (158.0)	131.0 (163.5)	140.5 (175.5)	139.0 (173.5)	147.0 (183.5)	
120/240	3	0.8	Delta	130.0 (162.5)	136.5 (170.5)	139.0 (173.5)	144.0 (180.0)	154.5 (193.0)	152.5 (190.5)	161.5 (201.5)	
120/240	1	1.0	Dogleg	81.0 (81.0)	90.5 (90.5)	95.0 (95.0)	105.0 (105.0)	106.0 (106.0)	106.0 (106.0)	106.0 (106.0)	
347/600	3	0.8	Wye	135.0 (169.0)	143.0 (179.0)	147.0 (184.0)	155.0 (194.0)	172.0 (215.0)	168.0 (210.0)	180.0 (225.0)	

\* All data tested in accordance with IEEE Standard 115. Kohler Co. reserves the right to change the design or specifications without notice and without any obligation or liability whatsoever.

Submittal Data: 139/240 Volts, 0.8 PF, 1800 RPM, 60 Hz, 3 Phase, 130°C Rise

	Symbol	PerUnit	Ohms		Symbol	Value
<b>Typical Cold Resistances</b>				<b>Typical Time Constants</b>		
Phase Resistance		0.031	0.008	Armature Short Circuit	T <sub>a</sub>	0.012 sec.
Rotor Resistance		20.58	5.239	Transient Short Circuit	T' <sub>d</sub>	0.154 sec.
<b>Typical Reactances</b>				Transient Open Circuit	T' <sub>do</sub>	1.728 sec.
Synchronous				<b>Typical Field Current</b>		
Direct	X <sub>d</sub>	4.982	1.268	Full Load	I <sub>fFL</sub>	21.1 amps
Quadrature	X <sub>q</sub>	2.468	0.628	No Load	I <sub>fNL</sub>	3.8 amps
Transient				<b>Typical Short Circuit Ratio</b>		0.201
Unsaturated	X' <sub>du</sub>	0.504	0.128	<b>Harmonic Distortion</b>		
Saturated	X' <sub>d</sub>	0.443	0.113	RMS Total Harmonic Distortion		4.04%
Subtransient				Max. Single Harmonic		5th
Direct	X'' <sub>d</sub>	0.171	0.044	Deviation Factor (No Load, L-L)		<5%
Quadrature	X'' <sub>q</sub>	0.169	0.043	Telephone Influence Factor		<50
Negative Sequence	X <sub>2</sub>	0.17	0.043	<b>Insulation Class</b>		
Zero Sequence	X <sub>0</sub>	0.013	0.003	per NEMA MG1-1.66		H
				<b>Phase Rotation</b>		ABC

**4S12X, 60 Hz, 139/240, 277/480 Volts, Wye  
TYPICAL ALTERNATOR EFFICIENCY\***

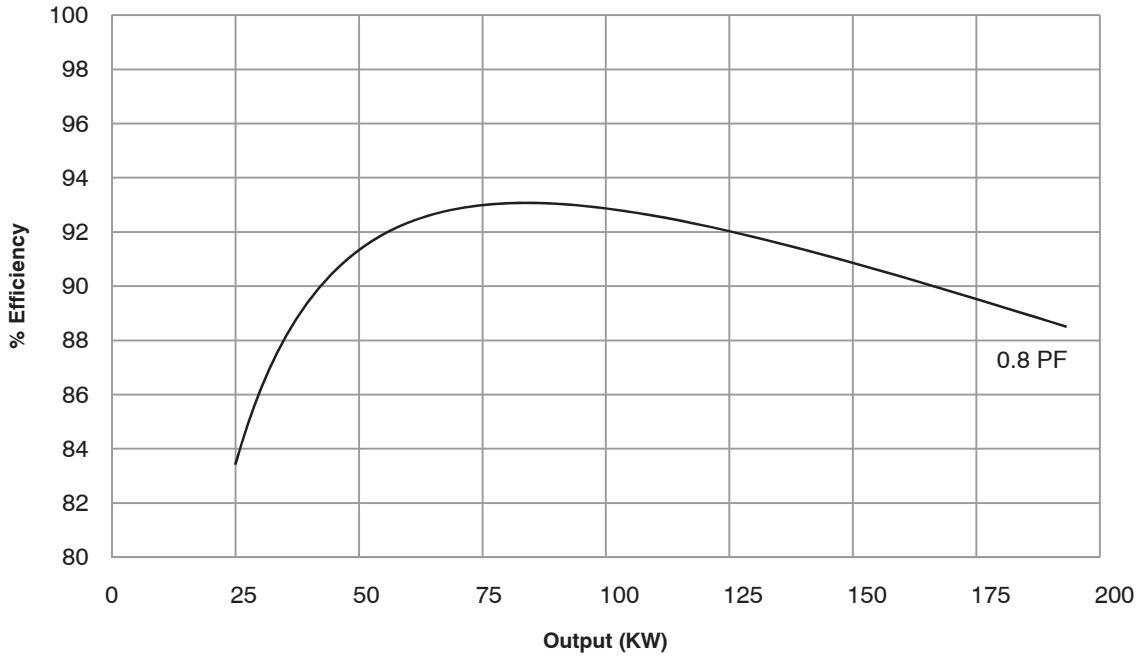

**4S12X, 60 Hz, 139/240, 277/480 Volts, Wye  
TYPICAL MOTOR STARTING CHARACTERISTICS\***

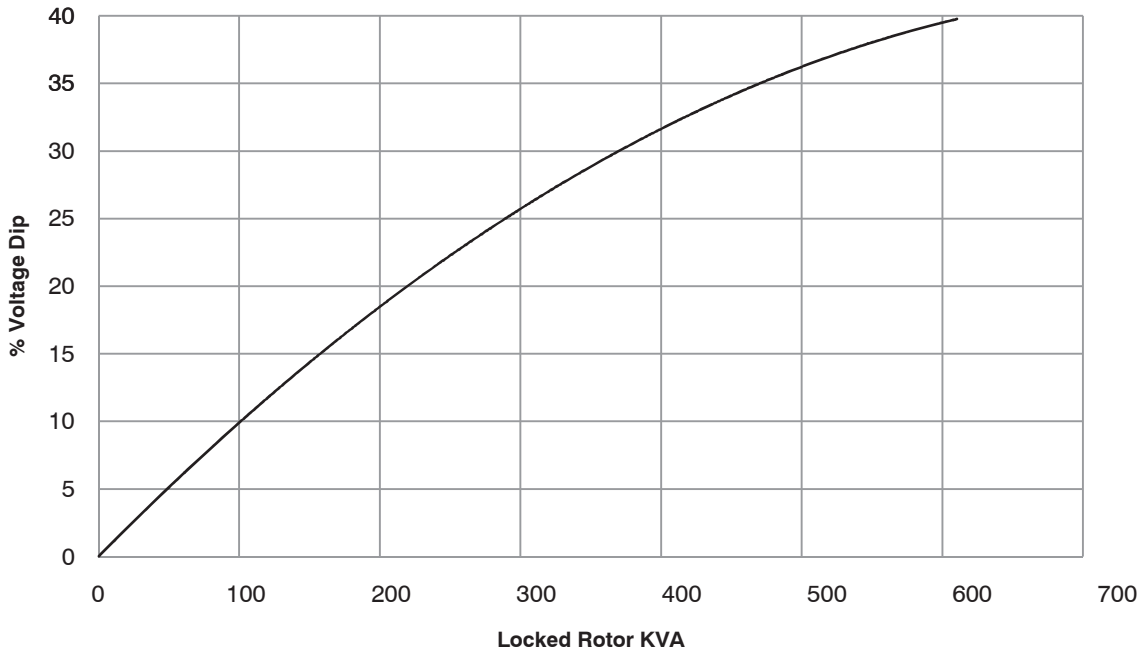

\* All data tested in accordance with IEEE Standard 115. Kohler Co. reserves the right to change the design or specifications without notice and without any obligation or liability whatsoever.

**4S12X, 60 Hz, High Wye Connection  
SHORT CIRCUIT DECREMENT CURVE**

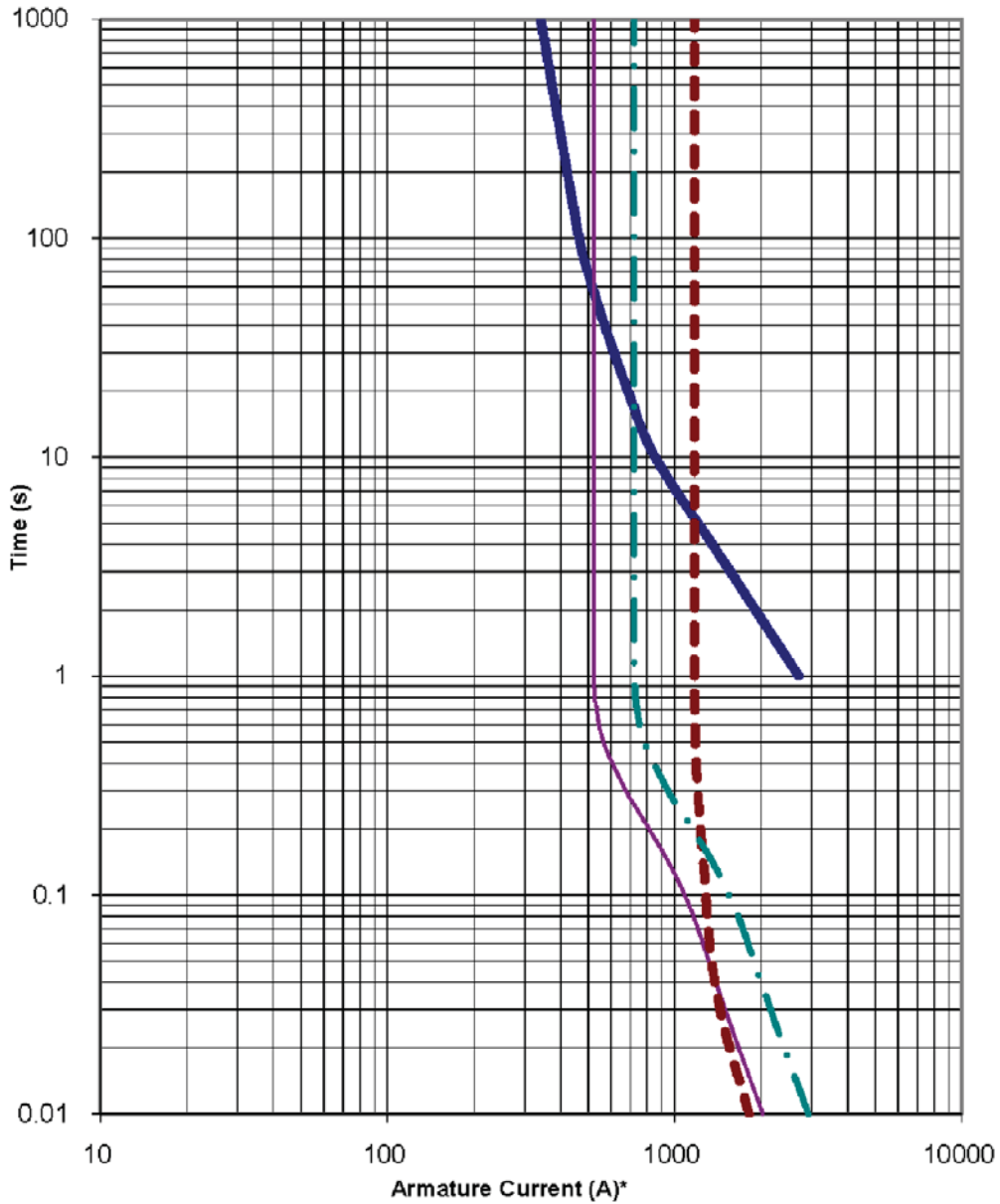

\*Instantaneous current (t=0) is asymmetric. Divide by 1.73 for symmetric.

**KOHLER®**

# Cooling Data

**TECHNICAL INFORMATION BULLETIN**

**Generator Set Cooling System Data Sheet**

180REOZJG 60Hz (Standby Duty)	50°C Ambient Temperature Cooling System								
	<b>Total external restriction on open unit<sup>7</sup></b>	Pa <i>(in.H<sub>2</sub>O)</i>	0 (0)	125 (0.5)	187 (0.75)	250 (1)	312 (1.25)	375 (1.5)	<b>Enclosed Units</b>
	<b>Maximum allowable ambient temperature</b>	°C <i>(°F)</i>	56 (133)	53 (127)	51 (124)	49 (120)	47 (117)	NA (NA)	49 (120)
	<b>Cooling system airflow</b>	m <sup>3</sup> /min <i>(ft<sup>3</sup>/min)</i>	368 (13000)	344 (12100)	333 (11800)	322 (11400)	310 (10900)	NA (NA)	NA (NA)

1. The data shown above is the anticipated cooling performance for a typical generator set when following proper installation techniques.
2. Cooling performance is based on operation at 100 m (328 ft.) above sea level. For elevations higher than 100 m (328 ft.), typical cooling performance derate is 1°C (1.8°F) per 250 m (820 ft.).
3. For high ambient conditions, check TIB-101 for the generator set power output derate schedule.
4. Incorrect installation, improper operation, fouling of the cooling system, and other variable conditions may reduce cooling performance.
5. Kohler manufactured sound enclosed models are rated in free air with no additional restriction. Consult factory for other variants or conditions such as additional ducting or hoods.
6. Performance is based on a 50/50 water and ethylene glycol mixture.
7. Total external restriction includes restriction upstream and downstream of the unit – any ducting supplying intake air to the unit and any ducting for the discharge.

**KOHLER®**

# Sound Data

**TECHNICAL INFORMATION BULLETIN**

**Generator Set Sound Data Sheet**

		Sound Pressure Data in dB(A)				
Generator Set Model	Hz	Load	Raw Exhaust	Open Unit, Isolated Exhaust	Weather Enclosure	Sound Enclosure
180REOZJG	60	100% Load	114.0	87.1	85.2	72.7
		No Load	102.9	85.1	83.2	70.0

Note: Sound pressure data is the logarithmic average of eight perimeter measurement points at a distance of 7 m (23 ft.), except Raw Exhaust data which is a single measurement point at 1 m (3.3 ft.) from the mouth of a straight pipe exhaust.

180REOZJG		60Hz		Sound Pressure Levels dB(A)								
Load	Distance, m (ft)	Enclosure	Measurement Position	Octave Band Center Frequency (Hz)								Overall Level
				63	125	250	500	1000	2000	4000	8000	
100% Load	7 (23)	Sound	Right	59.5	66.9	66.0	66.9	64.0	64.1	62.9	53.6	73.4
			Front-Right	55.5	62.9	63.3	66.9	64.0	61.6	60.5	49.2	71.6
			Front	57.1	64.6	66.2	66.4	65.3	62.4	60.2	50.7	72.6
			Front-Left	56.1	63.9	64.7	65.7	64.7	65.7	62.1	51.5	72.6
			Left	54.4	62.2	67.5	65.8	63.8	64.5	61.3	52.9	72.6
			Back-Left	50.6	57.9	67.9	62.8	61.3	61.6	59.1	48.1	71.0
			Back	57.9	64.9	72.9	66.2	62.7	61.6	58.4	50.8	75.0
			Back-Right	55.5	62.9	67.6	63.0	62.3	63.1	58.8	50.7	71.7
8-pos. log avg.			56.4	63.9	68.0	65.7	63.7	63.3	60.7	51.3	72.7	

				Sound Pressure Levels dB(A)								
Load	Distance, m (ft)	Enclosure	Measurement Position	Right	Front-Right	Front	Front-Left	Left	Back-Left	Back	Back-Right	8-pos. log avg.
100% Load	7 (23)	Weather	Overall Levels	84.8	85.3	85.2	88.3	87.0	83.4	80.6	82.3	85.2

				Sound Pressure Levels dB(A)								
Load	Distance, m (ft)	Enclosure	Measurement Position	Octave Band Center Frequency (Hz)								Overall Level
				63	125	250	500	1000	2000	4000	8000	
100% Load	7 (23)	Open Unit, Isolated Exhaust	Right	52.2	63.0	77.8	76.0	81.8	80.0	79.6	72.3	86.7
			Front-Right	50.5	59.7	71.9	82.6	81.8	79.7	78.3	70.6	87.2
			Front	55.4	61.6	78.2	77.5	82.2	81.8	78.0	69.8	87.1
			Front-Left	51.3	62.4	80.2	81.4	85.7	84.6	80.8	72.2	90.2
			Left	52.0	62.4	76.3	81.9	84.1	82.8	80.5	72.8	88.9
			Back-Left	54.9	63.6	75.6	76.1	79.3	80.1	78.1	69.9	85.3
			Back	53.6	62.3	77.8	75.0	75.7	74.3	71.3	66.0	82.5
			Back-Right	53.7	62.7	76.3	76.3	78.3	77.7	76.1	68.4	84.2
8-pos. log avg.			53.3	62.3	77.3	79.3	82.1	81.0	78.6	70.7	87.1	

				Sound Pressure Levels dB(A)								
Load	Distance, m (ft)	Exhaust	Measurement Position	Octave Band Center Frequency (Hz)								Overall Level
				63	125	250	500	1000	2000	4000	8000	
100% Load	1 (3.3)	Raw Exhaust (No Silencer)		85.9	94.4	101.7	105.0	109.3	107.9	106.3	99.8	114.0

180REOZJG		60Hz		Sound Pressure Levels dB(A)								
Load	Distance, m (ft)	Enclosure	Measurement Position	Octave Band Center Frequency (Hz)								Overall Level
				63	125	250	500	1000	2000	4000	8000	
No Load	7 (23)	Sound	Right	52.8	60.4	63.6	64.4	59.7	61.2	58.2	49.0	69.7
			Front-Right	50.4	57.9	61.9	64.3	60.1	57.0	52.1	42.3	68.3
			Front	53.1	60.5	64.9	63.1	61.5	58.6	54.5	45.7	69.5
			Front-Left	50.7	58.5	62.9	62.0	62.7	62.9	57.4	46.2	69.4
			Left	49.7	57.5	65.1	61.6	60.0	62.4	57.1	47.9	69.4
			Back-Left	47.1	54.3	68.2	61.0	57.9	58.7	55.1	42.7	69.9
			Back	51.7	58.2	71.5	63.6	59.9	58.6	54.1	45.5	72.8
			Back-Right	49.1	56.7	66.7	61.1	57.8	58.9	53.8	45.2	69.1
8-pos. log avg.			51.0	58.4	66.7	62.8	60.2	60.2	55.7	46.1	70.0	

Sound Pressure Levels dB(A)												
Load	Distance, m (ft)	Enclosure	Measurement Position	Right	Front-Right	Front	Front-Left	Left	Back-Left	Back	Back-Right	8-pos. log avg.
No Load	7 (23)	Weather	Overall Levels	83.0	84.6	84.0	86.1	82.5	81.0	79.4	80.8	83.2

Sound Pressure Levels dB(A)												
Load	Distance, m (ft)	Measurement Position	Octave Band Center Frequency (Hz)								Overall Level	
			63	125	250	500	1000	2000	4000	8000		
No Load	7 (23)	Open Unit, Isolated Exhaust	Right	45.5	59.2	78.4	75.3	80.3	77.6	75.5	67.5	84.9
			Front-Right	42.7	55.7	70.3	83.3	80.3	78.3	76.3	68.5	86.5
			Front	48.0	60.0	77.7	77.7	78.7	81.4	76.7	68.5	85.9
			Front-Left	46.4	59.5	78.8	79.6	83.9	81.6	77.8	69.4	88.0
			Left	47.5	59.8	74.4	76.3	80.5	77.4	75.1	66.5	84.4
			Back-Left	42.7	57.4	74.7	74.9	76.6	77.9	73.7	64.6	82.9
			Back	45.1	59.1	78.1	74.7	73.3	71.3	66.9	57.5	81.3
			Back-Right	45.5	58.5	76.0	75.9	76.8	75.4	73.4	64.9	82.7
8-pos. log avg.			45.8	58.8	76.7	78.3	79.8	78.5	75.2	66.9	85.1	

Sound Pressure Levels dB(A)											
Load	Distance, m (ft)	Exhaust	Octave Band Center Frequency (Hz)							Overall Level	
			63	125	250	500	1000	2000	4000		8000
No Load	1 (3.3)	Raw Exhaust (No Silencer)	81.6	89.7	92.9	95.7	97.6	96.0	94.2	85.4	102.9

**KOHLER®**

# Exhaust System Data

---

## TECHNICAL INFORMATION BULLETIN

---

### Enclosed Generator Set Exhaust System Data Sheet

Model	Enclosure Type	Consumed Back Pressure (in H2O)	Consumed Back Pressure (in Hg)	Back Pressure Limit(s) (in H2O)	Back Pressure Limit(s) (in Hg)	Flex Exhaust Tube(s)	Silencer	Drawing
180REOZJG	All Weather & Sound Enclosures	23.5	1.7	12-30	0.9-2.2	GM73479	GM70083	ADV-7854

1. Total system exhaust back pressure is applicable to generator sets equipped with Kohler standard enclosure packages.
2. For generator sets with multiple exhaust outlets, total system exhaust back pressure value represents each outlet.
3. The total system back pressure should not exceed the manufacturer's recommended limit.
4. The total back pressure only includes exhaust components installed inside the Kohler enclosure. Customers must calculate any additional back pressure caused by piping, extensions, or components added after the silencer outlet. Refer to the installation manual for additional details.

**KOHLER®**

# Emissions Data



# 180REOZJG

## 60 HZ. DIESEL INDUSTRIAL GENERATOR SET EMISSION DATA SHEET

### ENGINE INFORMATION

Model:	John Deere, 6068HFG82	Bore:	106mm (4.19 in.)
Nameplate BHP @ 1800 RPM:	284	Stroke:	127mm (5.0 in.)
Type:	4-Cycle, 6 Cylinder, Inline	Displacement:	6.8 L (415 cu. in.)
Aspiration:	Turbocharged, Charge Air-Cooled	EPA Family:	RJDXL06.8120
Compression Ratio	17.0:1	EPA Certificate:	RJDXL06.8120-004

### PERFORMANCE DATA:

Engine bkW @ Stated Load  
Fuel Consumption (g/kWh)  
Exhaust Gas Flow (m<sup>3</sup>/min)  
Exhaust Temperature (°C)

Table 1

1/4 Standby	1/2 Standby	3/4 Standby	Full Standby
53	106	159	212
262	234	224	206
			30
			516

### EXHAUST EMISSION DATA:

HC (Total Unburned Hydrocarbons)  
NOx (Oxides of Nitrogen as NO<sub>2</sub>)  
CO (Carbon Monoxide)  
PM (Particulate Matter)

Table 2  
EPA D2 Cycle 5-mode weighted

0.12
3.79
1.2
0.12

Values are in g/kWh unless otherwise noted

### TEST METHODS AND CONDITIONS

The emission data listed is measured from a laboratory test engine according to the test procedures of 40 CFR 89 or 40 CFR 1039, as applicable. The test engine is intended to represent nominal production hardware, and there is no guarantee that every production engine will have identical test results. The family parent data represents multiple ratings and this data may have been collected at a different engine speed and load. Emission results may vary due to engine manufacturing tolerances, engine operating conditions, fuels used, alternate test methods, or other conditions.

Data and specifications subject to change without notice.



**UNITED STATES ENVIRONMENTAL PROTECTION AGENCY  
2024 MODEL YEAR  
CERTIFICATE OF CONFORMITY  
WITH THE CLEAN AIR ACT**

**OFFICE OF TRANSPORTATION  
AND AIR QUALITY  
ANN ARBOR, MICHIGAN 48105**

**Certificate Issued To:** Deere & Company  
(U.S. Manufacturer or Importer)  
**Certificate Number:** RJDXL06.8120-004

**Effective Date:**  
09/29/2023

**Expiration Date:**  
12/31/2024

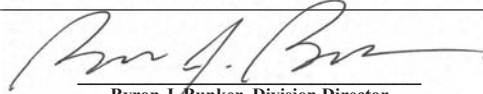
  
 Byron J. Bunker, Division Director  
 Compliance Division

**Issue Date:**  
09/29/2023

**Revision Date:**  
N/A

**Model Year:** 2024  
**Manufacturer Type:** Original Engine Manufacturer  
**Engine Family:** RJDXL06.8120

**Mobile/Stationary Indicator:** Stationary  
**Emissions Power Category:** 130<=kW<225  
**Fuel Type:** Diesel  
**After Treatment Devices:** No After Treatment Devices Installed  
**Non-after Treatment Devices:** Electronic Control, Smoke Puff Limiter, Engine Design Modification, Non-standard Non-After Treatment Device Installed

Pursuant to Section 111 and Section 213 of the Clean Air Act (42 U.S.C. sections 7411 and 7547) and 40 CFR Part 60, and subject to the terms and conditions prescribed in those provisions, this certificate of conformity is hereby issued with respect to the test engines which have been found to conform to applicable requirements and which represent the following engines, by engine family, more fully described in the documentation required by 40 CFR Part 60 and produced in the stated model year.

This certificate of conformity covers only those new compression-ignition engines which conform in all material respects to the design specifications that applied to those engines described in the documentation required by 40 CFR Part 60 and which are produced during the model year stated on this certificate of the said manufacturer, as defined in 40 CFR Part 60.

It is a term of this certificate that the manufacturer shall consent to all inspections described in 40 CFR 1068 and authorized in a warrant or court order. Failure to comply with the requirements of such a warrant or court order may lead to revocation or suspension of this certificate for reasons specified in 40 CFR Part 60. It is also a term of this certificate that this certificate may be revoked or suspended or rendered void *ab initio* for other reasons specified in 40 CFR Part 60.

This certificate does not cover engines sold, offered for sale, or introduced, or delivered for introduction, into commerce in the U.S. prior to the effective date of the certificate.

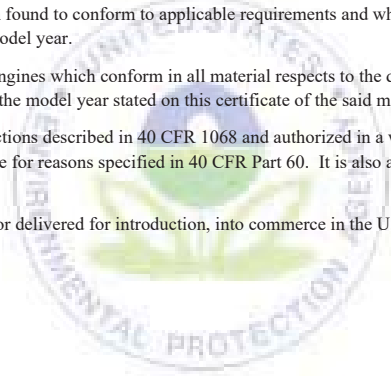

**KOHLER®**

# Dimensional Drawings

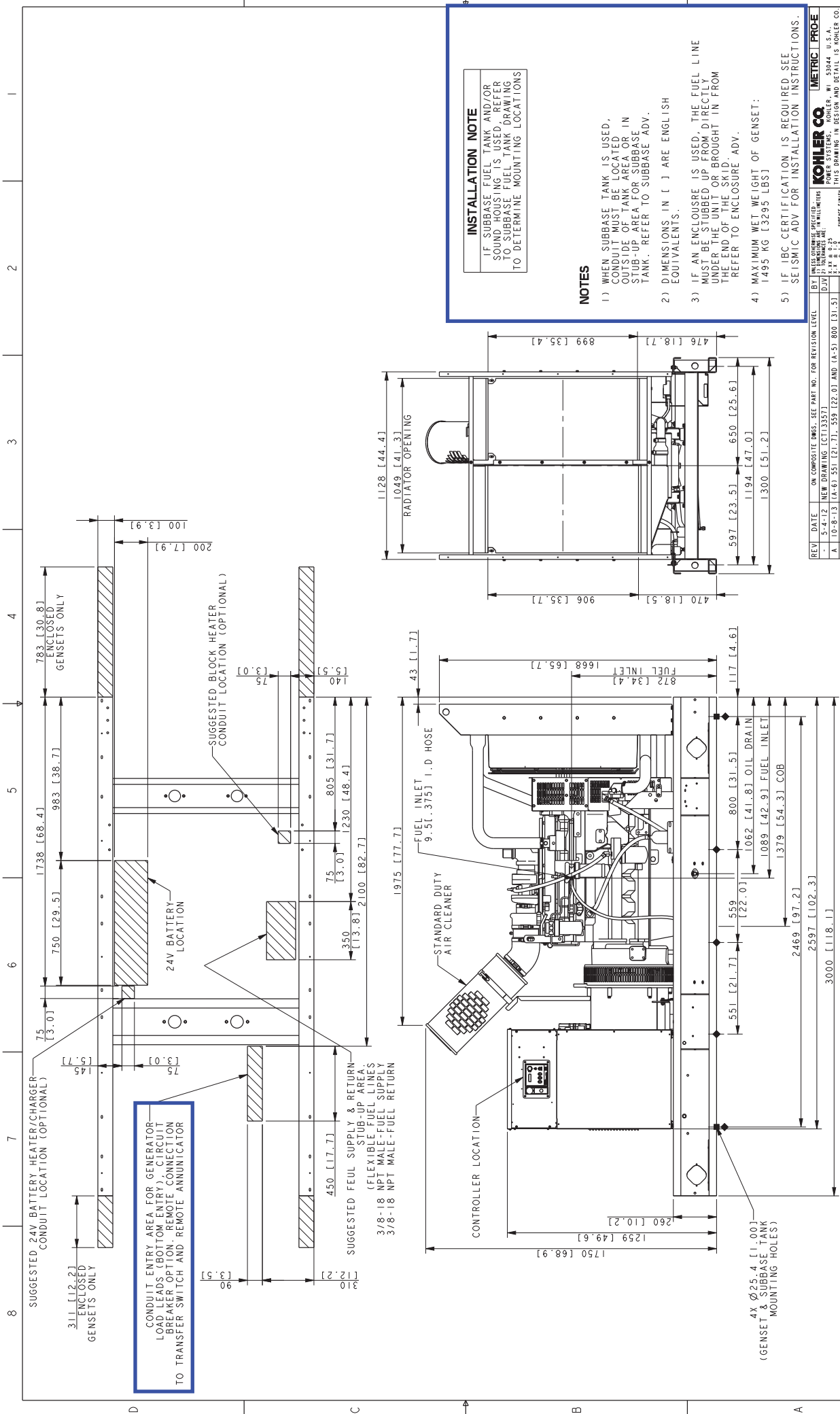

**INSTALLATION NOTE**  
 IF SUBBASE FUEL TANK AND/OR SOUND HOUSING IS USED, REFER TO SUBBASE FUEL TANK DRAWING TO DETERMINE MOUNTING LOCATIONS

- NOTES**
- 1) WHEN SUBBASE TANK IS USED, CONDUIT MUST BE LOCATED OUTSIDE OF TANK AREA OR IN STUB-UP AREA FOR SUBBASE TANK. REFER TO SUBBASE ADV.
  - 2) DIMENSIONS IN [ ] ARE ENGLISH EQUIVALENTS.
  - 3) IF AN ENCLOSURE IS USED, THE FUEL LINE MUST BE STUBBED UP FROM DIRECTLY UNDER THE UNIT OR BROUGHT IN FROM THE END OF THE SKID. REFER TO ENCLOSURE ADV.
  - 4) MAXIMUM WET WEIGHT OF GENSET: 1495 KG [3295 LBS]
  - 5) IF IBC CERTIFICATION IS REQUIRED, SEE SEISMIC ADV FOR INSTALLATION INSTRUCTIONS.

REV	DATE	ON COMPOSITE DIMS. SEE PART NO. FOR REVISION LEVEL	BY	DESIGNER/REVISION SPECIFIED	DATE	SCALE
-	5-4-12	NEW DRAWING [CT13357]	DJV	TRIMMERS ARE	5-4-12	0.10 [3.9]
A	10-8-13	(A-6) 551 [21.7], 559 [22.0] AND (A-5) 800 [31.5]		3.11 [12.2]	5-4-12	0.10 [3.9]
		ADDED: (A-8) NOTE FOR STANDARD AND IBC MOUNTING		30 SHIPMENT WEIGHT	5-4-12	0.10 [3.9]
		ADDED [C159187]		30 SHIPMENT WEIGHT	5-4-12	0.10 [3.9]

190-200 MODEL, 4512X, 4519X RECONNECTABLE IMPROVE MOTOR STARTING (IMS) RECONNECTABLE AND 600V ALTERNATORS JOHN DEERE 6068HF82, TIER III

- 4X25.4 [1.0] STANDARD MOUNTING
- ◆ 10X25.4 [1.0] IBC MOUNTING

**KOHLER CO. METRIC PROE**  
 THIS DRAWING IS THE PROPERTY OF KOHLER CO. AND IS NOT TO BE REPRODUCED OR TRANSMITTED IN ANY FORM OR BY ANY MEANS, ELECTRONIC OR MECHANICAL, INCLUDING PHOTOCOPYING, RECORDING, OR BY ANY INFORMATION STORAGE AND RETRIEVAL SYSTEM. ALL RIGHTS OF DESIGN OR INVENTION ARE RESERVED.

**DIMENSION PRINT, 180 REOZJG**  
 ADV-6473

MODEL	ENCLOSURE WEIGHT KG [LBS]
STEEL WEATHER	494 [1090]
STEEL SOUND	585 [1290]
ALUMINUM SOUND	300 [660]

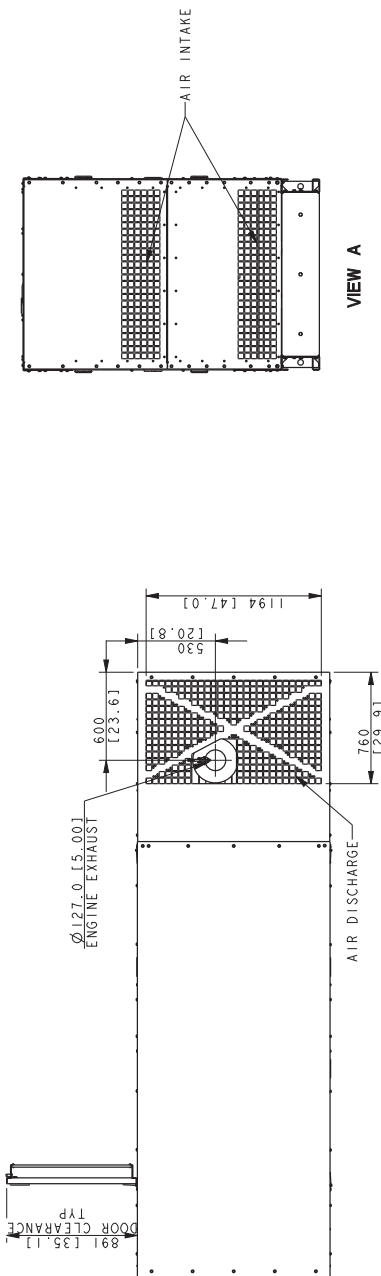

VIEW A

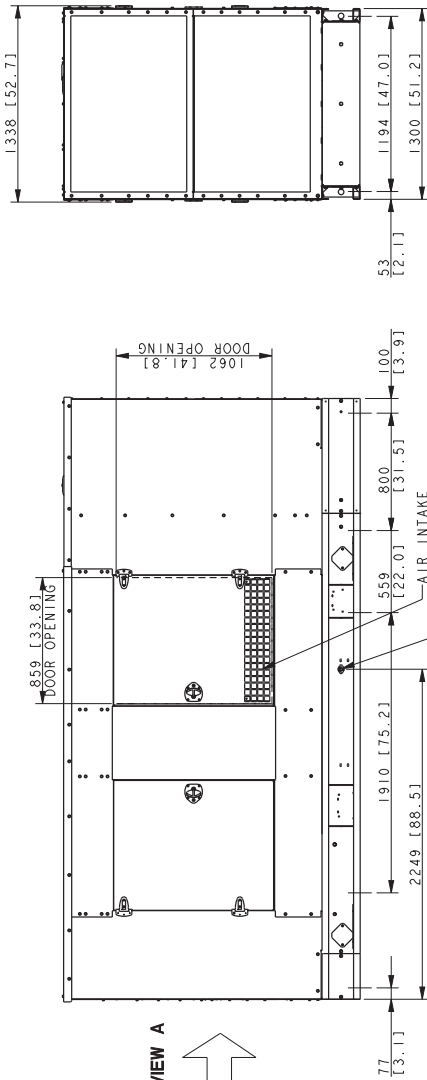

SEE VIEW A

DIMENSIONS IN [ ] ARE INCH EQUIVALENTS

REV	DATE	ON COMPOSITE DIMS. SEE PART NO. FOR REVISION LEVEL	BY	DESCRIPTION	PROJECT	METRIC	PROJ
G	10-31-12	SHEET 2 WAS SHEET. ADDED SHEET 1 [C128612]	CEP	REVISIONS	800000		
H	2-5-13	[A-1] 1-3 WAS 1-2. SEE SHEET 3 [C132174]	SAW				
J	10-31-13	SHEET 3 REMOVED. SEE SHEET 2 [C159787]	SRM				
K	9-25-17	[D-6] D.M. $\varnothing 127.0 [5.00]$ ADDED [C17170041]	SRM				
L	12-02-20	[C-4] VIEW A ADDED. SEE SHEET 2 [C17204051]	SSS				
			APPROVALS	DATE			
			DIV	2-11-10	SCALE	0.06	CR
			CHECKED				
			APPROVED				

180 MODEL 4S15, 4S12X, 4S13X  
200 MODEL 40A9, 40A10, 40A13X  
IMPROVE MOTOR STARTING (IMS), RECONNECTABLE  
& 600V ALTERNATORS  
6068HF485 JOHN DEERE TIER III

**NOTE:**  
ENCLOSURE ONLY MOUNTS TO SKID.  
FOR STUB-UP ACCESS DURING INSTALLATION THE  
REAR ENCLOSURE PANEL SHOULD BE REMOVED

CO.	PROJECT	DESCRIPTION	DATE	SCALE	CR
KOHLER CO.	800000	800000			

PROPERTY RIGHTS RESERVED. THIS DRAWING IS THE PROPERTY OF KOHLER CO. NO PART OF THIS DRAWING OR DESIGN OR INVENTION ARE TO BE REPRODUCED OR TRANSMITTED IN ANY FORM OR BY ANY MEANS, ELECTRONIC OR MECHANICAL, INCLUDING PHOTOCOPYING, RECORDING, OR BY ANY INFORMATION STORAGE AND RETRIEVAL SYSTEM.

APPROVED	DATE	SCALE	CR

DIMENSION PRINT, ENCLOSURE 180-200 JD  
ADV-7854  
SHEET 1 OF 2

MODEL	CAPACITY		WEIGHT		HEIGHT		E-Vent	
	LITERS	GAL	KG	LBS	MM	IN	SIZE (IN)	QTY
180/200KW	151.4	400	933	2057	482.6	19.0	4.0	2.0
180/200KW	267.1	708	1327	2926	689.0	33.0	3.0	2.0

**TANK FITTINGS:**  
 A. 1" NPT EMERGENCY VENT FITTING PER NFPA 30 WITH VENT CAPS  
 B. 2" NPT FUEL FILL FITTING WITH LOCKABLE "CAP"  
 C. 2" NPT FUEL LEVEL GAUGE FITTING  
 D. 2" NORMAL VENT FITTING WITH MUSHROOM VENT CAP AND 5" RISER  
 E. 2" NPT FITTING FOR REMOVABLE ENGINE SUPPLY DIP TUBE (3/8" NPT FEMALE WITH CHECK VALVE)  
 F. 2" NPT FITTING FOR REMOVABLE FUEL RETURN DIP TUBE (3/8" NPT FEMALE)  
 G. 2" NPT FOR LOW LEVEL SWITCH (SET AT 50% FULL, SILICONE PACKED)  
 H. 2" NPT ADDITIONAL FITTING FOR OPTIONAL ACCESSORY  
 I. 1/2" NPT BASEN GRANT (INSTALL IN STEEL 1/2" NPT PIPE PLUG)  
 J. 1/2" NPT FOR FUEL IN BASIN SWITCH (INSTALL STEEL 1/2" NPT PIPE PLUG)  
 K. 1/2" NPT FOR FUEL IN BASIN SWITCH (INSTALL STEEL 1/2" NPT PIPE PLUG)

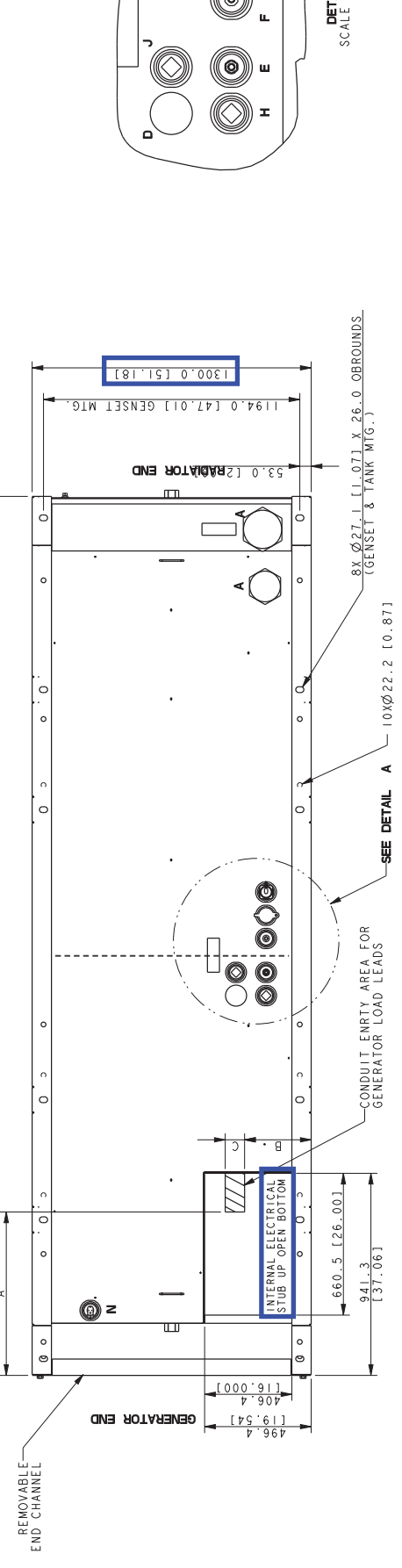

SCALE 0.20

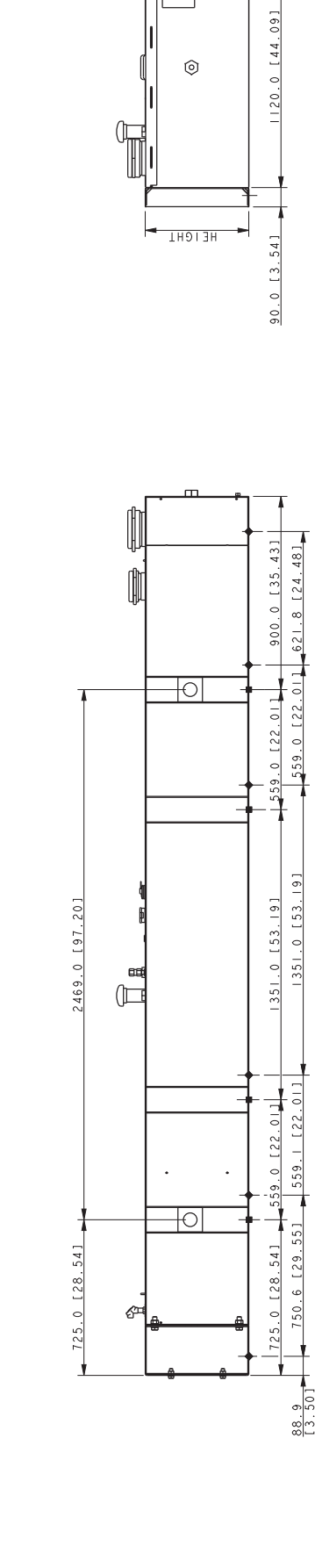

SCALE 0.10

REV	DATE	BY	DESCRIPTION	REVISION LEVEL
F	08-11-14	(A-4)	STANDARD TANK NOTE ADDED & SEE SHEET 2 [CT189102]	2
G	2-28-17	(A-8, A-7)	761 WAS 571, 303 WAS 195, (8-D, C-7) DELETE 50.0 UPDATE CONDUIT AREA.	3
H	2-19-18		SEE SHEET 2 [CT110607]	4
J	2-26-19	(A-5)	IBC/WINDLOAD MOUNTING WAS IBC MOUNTING. SEE SHEET 2 & 3 [CT198521]	5
K	7-2-19		SEE SHEET 2 [CT198521]	6

APPROVALS	DATE	SCALE	PROJ	APP
PAS		0.10	ADV-7859	
DES		0.10	ADV-7859	

GENSET	A	B	C
180KW	761 [30.0]	310 [12.2]	90 [3.5]
200KW	581 [22.1]	303 [11.9]	100 [3.9]

REV	DATE	BY	DESCRIPTION	REVISION LEVEL
F	08-11-14	(A-4)	STANDARD TANK NOTE ADDED & SEE SHEET 2 [CT189102]	2
G	2-28-17	(A-8, A-7)	761 WAS 571, 303 WAS 195, (8-D, C-7) DELETE 50.0 UPDATE CONDUIT AREA.	3
H	2-19-18		SEE SHEET 2 [CT110607]	4
J	2-26-19	(A-5)	IBC/WINDLOAD MOUNTING WAS IBC MOUNTING. SEE SHEET 2 & 3 [CT198521]	5
K	7-2-19		SEE SHEET 2 [CT198521]	6

APPROVALS	DATE	SCALE	PROJ	APP
PAS		0.10	ADV-7859	
DES		0.10	ADV-7859	

GENSET	A	B	C
180KW	761 [30.0]	310 [12.2]	90 [3.5]
200KW	581 [22.1]	303 [11.9]	100 [3.9]

REV	DATE	BY	DESCRIPTION	REVISION LEVEL
F	08-11-14	(A-4)	STANDARD TANK NOTE ADDED & SEE SHEET 2 [CT189102]	2
G	2-28-17	(A-8, A-7)	761 WAS 571, 303 WAS 195, (8-D, C-7) DELETE 50.0 UPDATE CONDUIT AREA.	3
H	2-19-18		SEE SHEET 2 [CT110607]	4
J	2-26-19	(A-5)	IBC/WINDLOAD MOUNTING WAS IBC MOUNTING. SEE SHEET 2 & 3 [CT198521]	5
K	7-2-19		SEE SHEET 2 [CT198521]	6

APPROVALS	DATE	SCALE	PROJ	APP
PAS		0.10	ADV-7859	
DES		0.10	ADV-7859	

  

GENSET	A	B	C
180KW	761 [30.0]	310 [12.2]	90 [3.5]
200KW	581 [22.1]	303 [11.9]	100 [3.9]

8X Ø25.4 [1.0] STANDARD MOUNTING  
 12X Ø22.2 [0.88] IBC/WINDLOAD MOUNTING  
 180 MODEL 60HZ 455, 4512X & 4519X  
 200 MODEL 40A8 RECINGENSTABLE  
 IMPROVED MOTOR STARTING (MS) &  
 600V ALTERNATOR  
 JOHN DEERE 6068HF485, TIER III

PART NO.	REV	ITEM 1	ITEM 2	ITEM 3	COMMENTS
GM85123-1	C	GM85127	GM86126-1	GM86126-1	MULTIPLE ATS
GM85123-2	C	GM85131	GM85129	GM86126-2	SINGLE ATS
GM85123-3	C	GM85132	-	GM86126-3	ANNUNCIATOR ONLY
GM85123-4	C	GM85133	-	GM86126-3	SDMO - ANNUNCIATOR UNIT

- NOTES:
- FUNCTIONALLY TEST ACCORDING TO ISO DOCUMENT ETF-WI-001, PER SPECIFICATION ETF-ID-003.
  - ASSEMBLE PCBA TO BACK OF BEZEL USING FIXTURE JT-0001.
  - TORQUE ALL SCREWS TO 7-10 in lbs.
  - PEEL BACKING OFF FACE PLATE AND APPLY TO BEZEL. APPLY EVEN PRESSURE TO ENTIRE SURFACE TO ENSURE COMPLETE ADHESION.

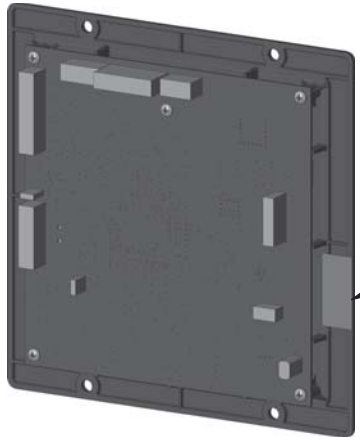

32000.00111 (0.135 FT.)  
PER ISO SPEC.  
CMP-080-115.

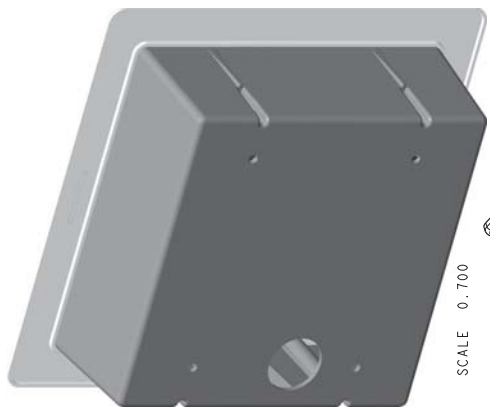

SCALE 0.700



SCALE 0.700

GM88463  
PER ISO SPEC  
GMP-080-110  
SEE VIEW B

GMZ3307 (5)

- GM62466-KPI (REF)  
POWER SUPPLY (OPTION)  
25486 00375 (0.25 FT) (REF)
- GM60407 (REF)
- GM60404 (REF)
- X-67-113 (REF)
- GM20930 (REF)  
(CONNECT TO P38)

NOTE:  
FOR WIRING DIAGRAM, SEE GM62554.

INDICATES PART NUMBERS AFFECTED BY LATEST DRAWING REVISION

REV	DATE	DESCRIPTION	BY	APPROVALS	DATE	SCALE	COR.
-	7-20-12	NEW DRAWING	CT19745	BTM	7-20-12	0.80	
A	5-28-13	[C-3] GM88463 WAS GM13213; [C148047]		BTM	5-28-13		
B	10-30-13	[C-4] 32000.00111 (0.135 FT.) & NOTE ADDED; [C162712]		BTM	10-30-13		
C	8-29-14	[D-2] NOTES ADDED; (A-8) GM60403 REMOVED; [C191680]		BTM	8-29-14		
D	12-22-18	VIEWS UPDATED; SEE SHEET 2 [C1168423]		BTM	12-22-18		

UNLESS OTHERWISE SPECIFIED, ALL DIMENSIONS ARE IN MILLIMETERS.  
KOHLER CO. METRIC PROE  
THIS DRAWING IS THE PROPERTY OF KOHLER CO. AND SHALL BE USED ONLY FOR THE PROJECT AND NOT BE REPRODUCED OR COPIED IN ANY MANNER WITHOUT THE WRITTEN PERMISSION OF KOHLER CO. ALL RIGHTS OF DESIGN OR INVENTION ARE RESERVED.  
DWG. RSA III Assy  
SCALE 0.80 COR.  
DATE 7-20-12  
APP. BTM  
DATE 7-20-12  
APP. BTM  
DATE 7-20-12  
APP. BTM

RSA III  
GM85123  
SHEET 1 OF 2

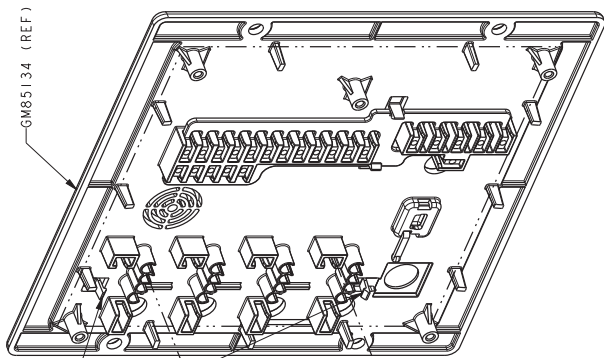

SNAP ITEM 2 INTO THIS LOCATION BEING SURE TO LINE UP ALL LIGHT SOCKETS TO MATCHING SOCKETS ON BEZEL.

BACK VIEW OF BEZEL  
SCALE 1:000

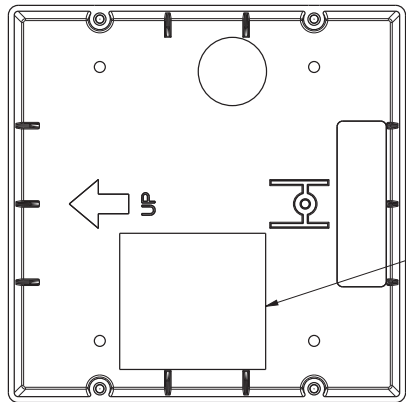

FRONT OF BOX

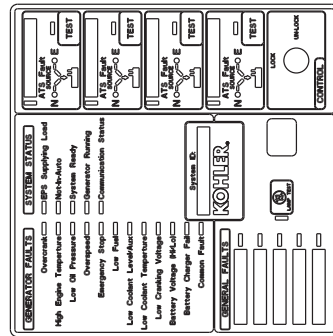

ITEM 1  
(P/N: GM8527 REF)

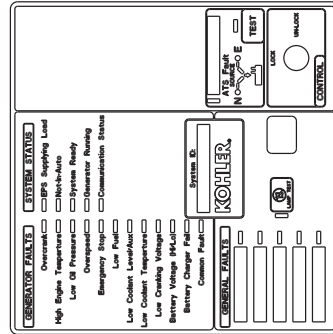

ITEM 1  
(P/N: GM8531 REF)

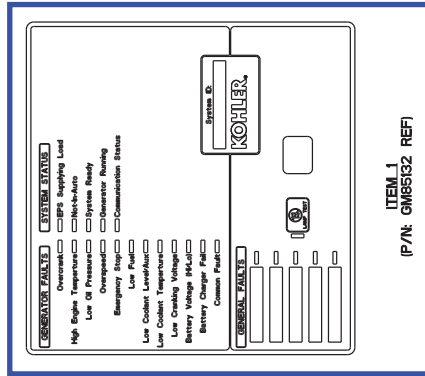

ITEM 1  
(P/N: GM8532 REF)

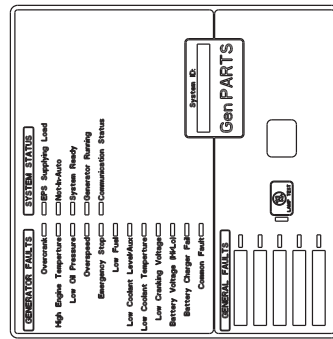

ITEM 1  
(P/N: GM8533 REF)

REV	DATE	DESCRIPTION	BY	CHK	APP	DATE	SCALE	PROJ
-	7-30-12	NEW DRAWING [CT19745]	BTM			7-30-12	0.80	GEN
A	5-28-13	(A-8) GM88463 (REF) WAS GMI3213 (REF); [CT48047]	BTM			5-28-13		GEN
B	10-30-13	SEE SHEET 1 [CT62712]	BTM			10-30-13		GEN
C	8-29-14	VIEW A REMOVED; [CT191680]	BTM			8-29-14		GEN
D	12-22-16	VIEWS UPDATED; SEE SHEET 1 [CT168423]	BTM			12-22-16		GEN

UNLESS OTHERWISE SPECIFIED, ALL DIMENSIONS ARE IN MILLIMETERS AND DECIMALS ARE IN THIRDS.  
THIS DRAWING IS THE PROPERTY OF KOHLER CO. AND IS NOT TO BE REPRODUCED OR TRANSMITTED IN ANY FORM OR BY ANY MEANS, ELECTRONIC OR MECHANICAL, INCLUDING PHOTOCOPYING, RECORDING, OR BY ANY INFORMATION STORAGE AND RETRIEVAL SYSTEM. ALL RIGHTS OF DESIGN OR INVENTION ARE RESERVED.

SCALE: 0.80 (1/8")  
DWG. NO.: GM85123  
SHEET 2 OF 2

**KOHLER®**

# Wiring Schematics

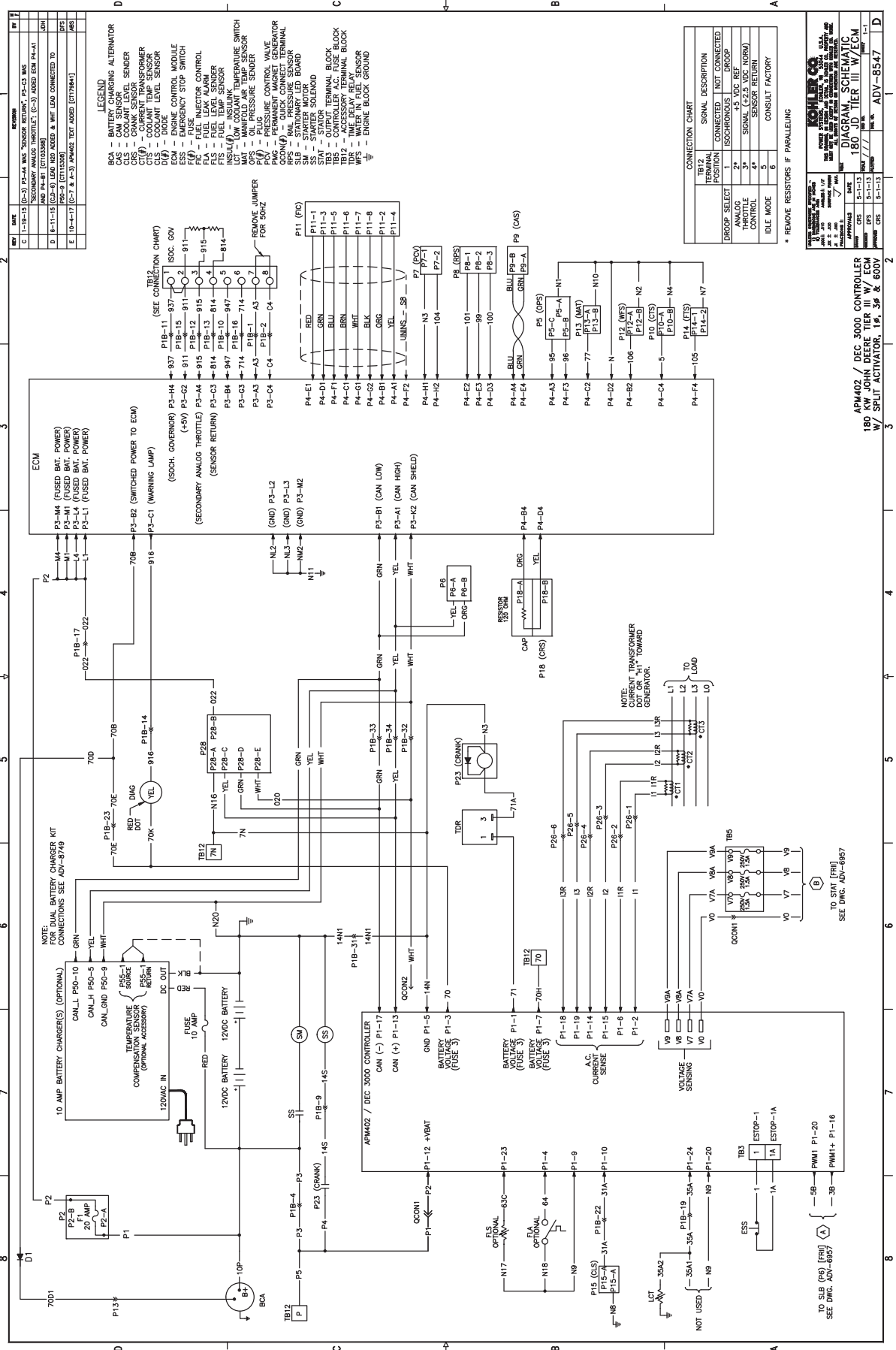

REV	DATE	DESCRIPTION	BY	CHK
1	11-15-15	(D-3) P3-A W/ SENSOR RETURN, P3-C3 W/ SENS		
2	11-15-15	SECONDARY ANALOG THROTTLE, (C-3) ADED ECM P4-A1		
3	11-15-15	DIAG LED, (C-2) W/ WIT LAMP CONNECTED TO		
4	11-15-15	DIAG LED, (C-2) W/ WIT LAMP CONNECTED TO		
5	10-17-17	(C-7, & A-3) ANM402 TEXT ADED (171941)		
6				

APR402 / DEC 3000 CONTROLLER  
 180 KW JOHN DEERE TIER III W/ ECM  
 W/ SPLIT ACTIVATOR, 18', 3# & 600V

TO SEE (R8) [F80]  
 SEE DWG. ADV-6957

TO START [F80]  
 SEE DWG. ADV-6957

TO SEE (R8) [F80]  
 SEE DWG. ADV-6957

TO START [F80]  
 SEE DWG. ADV-6957

TO SEE (R8) [F80]  
 SEE DWG. ADV-6957

TO START [F80]  
 SEE DWG. ADV-6957

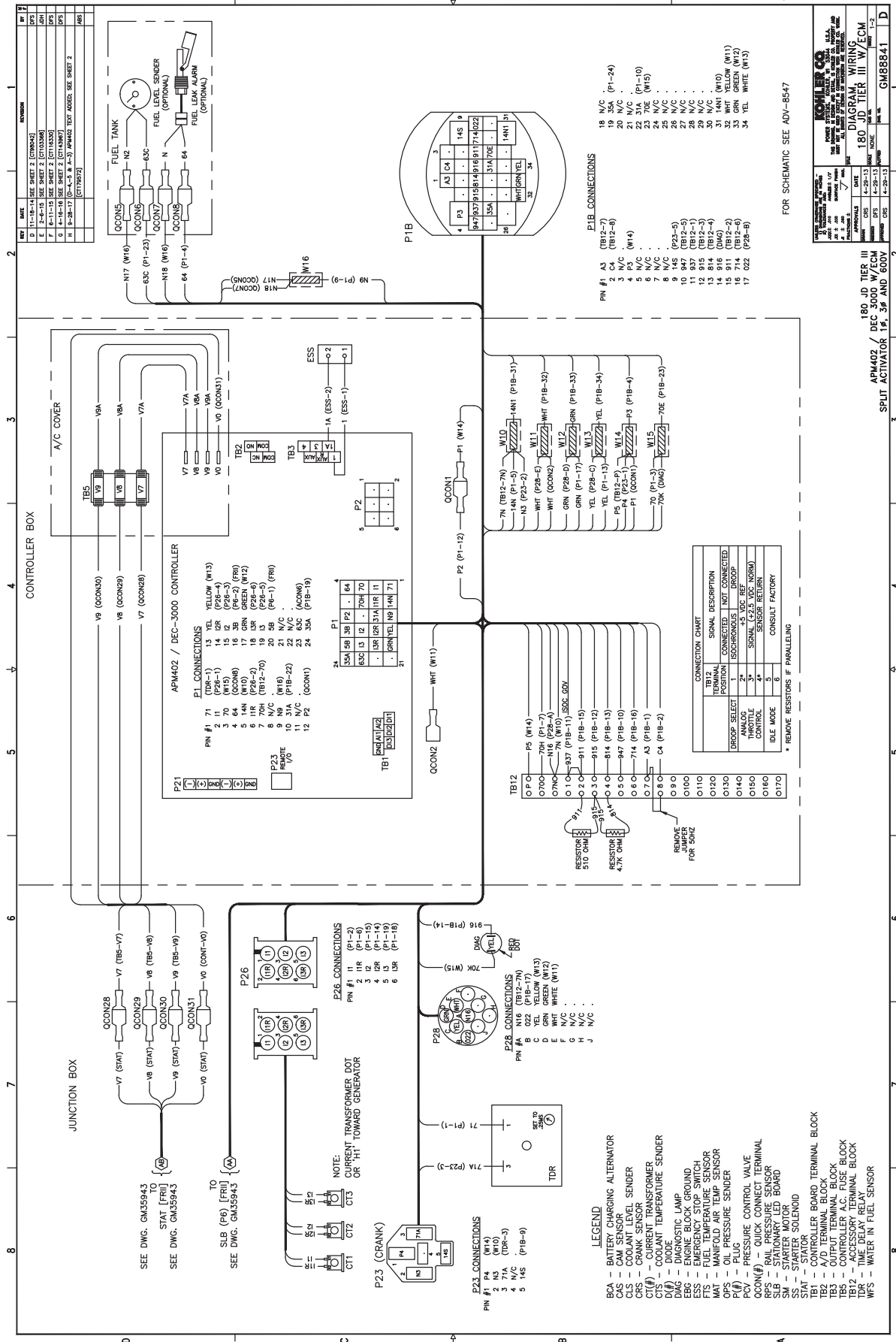

FOR SCHEMATIC SEE ADV-8547

REVISIONS

REV	DATE	DESCRIPTION
D	11-14-14	SEE SHEET 2 (CT10304)
E	2-4-15	SEE SHEET 2 (CT10306)
F	4-11-15	SEE SHEET 2 (CT10300)
G	8-18-15	SEE SHEET 2 (CT10305)
H	8-18-15	SEE SHEET 2 (CT10303)
I	12-23-17	REV. 1-15 (P23-1)
J	12-23-17	REV. 1-15 (P23-2)
K	12-23-17	REV. 1-15 (P23-3)
L	12-23-17	REV. 1-15 (P23-4)
M	12-23-17	REV. 1-15 (P23-5)

PL CONNECTIONS

13	YEL	(W13)
14	GR	(P28-4)
15	GR	(P28-5)
16	GRN	(P28-2)
17	GRN	(FR1)
18	GRN	(W10)
19	GRN	(P28-6)
20	GRN	(P28-7)
21	GRN	(P28-8)
22	GRN	(P28-9)
23	GRN	(P28-10)
24	GRN	(P28-11)
25	GRN	(P28-12)
26	GRN	(P28-13)
27	GRN	(P28-14)
28	GRN	(P28-15)
29	GRN	(P28-16)
30	GRN	(P28-17)
31	GRN	(P28-18)
32	GRN	(P28-19)
33	GRN	(P28-20)
34	GRN	(P28-21)

P1 CONNECTIONS

1	GRN	(P1-1)
2	GRN	(P1-2)
3	GRN	(P1-3)
4	GRN	(P1-4)
5	GRN	(P1-5)
6	GRN	(P1-6)
7	GRN	(P1-7)
8	GRN	(P1-8)
9	GRN	(P1-9)
10	GRN	(P1-10)
11	GRN	(P1-11)
12	GRN	(P1-12)
13	GRN	(P1-13)
14	GRN	(P1-14)
15	GRN	(P1-15)
16	GRN	(P1-16)
17	GRN	(P1-17)
18	GRN	(P1-18)
19	GRN	(P1-19)
20	GRN	(P1-20)
21	GRN	(P1-21)
22	GRN	(P1-22)
23	GRN	(P1-23)
24	GRN	(P1-24)
25	GRN	(P1-25)
26	GRN	(P1-26)
27	GRN	(P1-27)
28	GRN	(P1-28)
29	GRN	(P1-29)
30	GRN	(P1-30)
31	GRN	(P1-31)
32	GRN	(P1-32)
33	GRN	(P1-33)
34	GRN	(P1-34)

P2 CONNECTIONS

1	GRN	(P2-1)
2	GRN	(P2-2)
3	GRN	(P2-3)
4	GRN	(P2-4)
5	GRN	(P2-5)
6	GRN	(P2-6)
7	GRN	(P2-7)
8	GRN	(P2-8)
9	GRN	(P2-9)
10	GRN	(P2-10)
11	GRN	(P2-11)
12	GRN	(P2-12)
13	GRN	(P2-13)
14	GRN	(P2-14)
15	GRN	(P2-15)
16	GRN	(P2-16)
17	GRN	(P2-17)
18	GRN	(P2-18)
19	GRN	(P2-19)
20	GRN	(P2-20)
21	GRN	(P2-21)
22	GRN	(P2-22)
23	GRN	(P2-23)
24	GRN	(P2-24)
25	GRN	(P2-25)
26	GRN	(P2-26)
27	GRN	(P2-27)
28	GRN	(P2-28)
29	GRN	(P2-29)
30	GRN	(P2-30)
31	GRN	(P2-31)
32	GRN	(P2-32)
33	GRN	(P2-33)
34	GRN	(P2-34)

P3 CONNECTIONS

1	GRN	(P3-1)
2	GRN	(P3-2)
3	GRN	(P3-3)
4	GRN	(P3-4)
5	GRN	(P3-5)
6	GRN	(P3-6)
7	GRN	(P3-7)
8	GRN	(P3-8)
9	GRN	(P3-9)
10	GRN	(P3-10)
11	GRN	(P3-11)
12	GRN	(P3-12)
13	GRN	(P3-13)
14	GRN	(P3-14)
15	GRN	(P3-15)
16	GRN	(P3-16)
17	GRN	(P3-17)
18	GRN	(P3-18)
19	GRN	(P3-19)
20	GRN	(P3-20)
21	GRN	(P3-21)
22	GRN	(P3-22)
23	GRN	(P3-23)
24	GRN	(P3-24)
25	GRN	(P3-25)
26	GRN	(P3-26)
27	GRN	(P3-27)
28	GRN	(P3-28)
29	GRN	(P3-29)
30	GRN	(P3-30)
31	GRN	(P3-31)
32	GRN	(P3-32)
33	GRN	(P3-33)
34	GRN	(P3-34)

P4 CONNECTIONS

1	GRN	(P4-1)
2	GRN	(P4-2)
3	GRN	(P4-3)
4	GRN	(P4-4)
5	GRN	(P4-5)
6	GRN	(P4-6)
7	GRN	(P4-7)
8	GRN	(P4-8)
9	GRN	(P4-9)
10	GRN	(P4-10)
11	GRN	(P4-11)
12	GRN	(P4-12)
13	GRN	(P4-13)
14	GRN	(P4-14)
15	GRN	(P4-15)
16	GRN	(P4-16)
17	GRN	(P4-17)
18	GRN	(P4-18)
19	GRN	(P4-19)
20	GRN	(P4-20)
21	GRN	(P4-21)
22	GRN	(P4-22)
23	GRN	(P4-23)
24	GRN	(P4-24)
25	GRN	(P4-25)
26	GRN	(P4-26)
27	GRN	(P4-27)
28	GRN	(P4-28)
29	GRN	(P4-29)
30	GRN	(P4-30)
31	GRN	(P4-31)
32	GRN	(P4-32)
33	GRN	(P4-33)
34	GRN	(P4-34)

P5 CONNECTIONS

1	GRN	(P5-1)
2	GRN	(P5-2)
3	GRN	(P5-3)
4	GRN	(P5-4)
5	GRN	(P5-5)
6	GRN	(P5-6)
7	GRN	(P5-7)
8	GRN	(P5-8)
9	GRN	(P5-9)
10	GRN	(P5-10)
11	GRN	(P5-11)
12	GRN	(P5-12)
13	GRN	(P5-13)
14	GRN	(P5-14)
15	GRN	(P5-15)
16	GRN	(P5-16)
17	GRN	(P5-17)
18	GRN	(P5-18)
19	GRN	(P5-19)
20	GRN	(P5-20)
21	GRN	(P5-21)
22	GRN	(P5-22)
23	GRN	(P5-23)
24	GRN	(P5-24)
25	GRN	(P5-25)
26	GRN	(P5-26)
27	GRN	(P5-27)
28	GRN	(P5-28)
29	GRN	(P5-29)
30	GRN	(P5-30)
31	GRN	(P5-31)
32	GRN	(P5-32)
33	GRN	(P5-33)
34	GRN	(P5-34)

P6 CONNECTIONS

1	GRN	(P6-1)
2	GRN	(P6-2)
3	GRN	(P6-3)
4	GRN	(P6-4)
5	GRN	(P6-5)
6	GRN	(P6-6)
7	GRN	(P6-7)
8	GRN	(P6-8)
9	GRN	(P6-9)
10	GRN	(P6-10)
11	GRN	(P6-11)
12	GRN	(P6-12)
13	GRN	(P6-13)
14	GRN	(P6-14)
15	GRN	(P6-15)
16	GRN	(P6-16)
17	GRN	(P6-17)
18	GRN	(P6-18)
19	GRN	(P6-19)
20	GRN	(P6-20)
21	GRN	(P6-21)
22	GRN	(P6-22)
23	GRN	(P6-23)
24	GRN	(P6-24)
25	GRN	(P6-25)
26	GRN	(P6-26)
27	GRN	(P6-27)
28	GRN	(P6-28)
29	GRN	(P6-29)
30	GRN	(P6-30)
31	GRN	(P6-31)
32	GRN	(P6-32)
33	GRN	(P6-33)
34	GRN	(P6-34)

P7 CONNECTIONS

1	GRN	(P7-1)
2	GRN	(P7-2)
3	GRN	(P7-3)
4	GRN	(P7-4)
5	GRN	(P7-5)
6	GRN	(P7-6)
7	GRN	(P7-7)
8	GRN	(P7-8)
9	GRN	(P7-9)
10	GRN	(P7-10)
11	GRN	(P7-11)
12	GRN	(P7-12)
13	GRN	(P7-13)
14	GRN	(P7-14)
15	GRN	(P7-15)
16	GRN	(P7-16)
17	GRN	(P7-17)
18	GRN	(P7-18)
19	GRN	(P7-19)
20	GRN	(P7-20)
21	GRN	(P7-21)
22	GRN	(P7-22)
23	GRN	(P7-23)
24	GRN	(P7-24)
25	GRN	(P7-25)
26	GRN	(P7-26)
27	GRN	(P7-27)
28	GRN	(P7-28)
29	GRN	(P7-29)
30	GRN	(P7-30)
31	GRN	(P7-31)
32	GRN	(P7-32)
33	GRN	(P7-33)
34	GRN	(P7-34)

P8 CONNECTIONS

1	GRN	(P8-1)
2	GRN	(P8-2)
3	GRN	(P8-3)
4	GRN	(P8-4)
5	GRN	(P8-5)
6	GRN	(P8-6)
7	GRN	(P8-7)
8	GRN	(P8-8)
9	GRN	(P8-9)
10	GRN	(P8-10)
11	GRN	(P8-11)
12	GRN	(P8-12)
13	GRN	(P8-13)
14	GRN	(P8-14)
15	GRN	(P8-15)
16	GRN	(P8-16)
17	GRN	(P8-17)
18	GRN	(P8-18)
19	GRN	(P8-19)
20	GRN	(P8-20)
21	GRN	(P8-21)
22	GRN	(P8-22)
23	GRN	(P8-23)
24	GRN	(P8-24)
25	GRN	(P8-25)
26	GRN	(P8-26)
27	GRN	(P8-27)
28	GRN	(P8-28)
29	GRN	(P8-29)
30	GRN	(P8-30)
31	GRN	(P8-31)
32	GRN	(P8-32)
33	GRN	(P8-33)
34	GRN	(P8-34)

P9 CONNECTIONS

1	GRN	(P9-1)
2	GRN	(P9-2)
3	GRN	(P9-3)
4	GRN	(P9-4)
5	GRN	(P9-5)
6	GRN	(P9-6)
7	GRN	(P9-7)
8	GRN	(P9-8)
9	GRN	(P9-9)
10	GRN	(P9-10)
11	GRN	(P9-11)
12	GRN	(P9-12)
13	GRN	(P9-13)
14	GRN	(P9-14)
15	GRN	(P9-15)
16	GRN	(P9-16)
17	GRN	(P9-17)
18	GRN	(P9-18)
19	GRN	(P9-19)
20	GRN	(P9-20)
21	GRN	(P9-21)
22	GRN	(P9-22)
23	GRN	(P9-23)
24	GRN	(P9-24)
25	GRN	(P9-25)
26	GRN	(P9-26)
27	GRN	(P9-27)
28	GRN	(P9-28)
29	GRN	(P9-29)
30	GRN	(P9-30)
31	GRN	(P9-31)
32	GRN	(P9-32)
33	GRN	(P9-33)
34	GRN	(P9-34)

P10 CONNECTIONS

1	GRN	(P10-1)
2	GRN	(P10-2)
3	GRN	(P10-3)
4	GRN	(P10-4)
5	GRN	(P10-5)
6	GRN	(P10-6)
7	GRN	(P10-7)
8	GRN	(P10-8)
9	GRN	(P10-9)
10	GRN	(P10-10)
11	GRN	(P10-11)
12	GRN	(P10-12)
13	GRN	(P10-13)
14	GRN	(P10-14)
15	GRN	(P10-15)
16	GRN	(P10-16)
17	GRN	(P10-17)
18	GRN	(P10-18)
19	GRN	(P10-19)
20	GRN	(P10-20)
21	GRN	(P10-21)
22	GRN	(P10-22)
23	GRN	(P10-23)
24	GRN	(P10-24)
25	GRN	(P10-25)
26	GRN	(P10-26)
27	GRN	(P10-27)
28	GRN	(P10-28)
29	GRN	(P10-29)
30	GRN	(P10-30)
31	GRN	(P10-31)
32	GRN	(P10-32)
33	GRN	(P10-33)
34	GRN	(P10-34)

P11 CONNECTIONS

1	GRN	(P11-1)
2	GRN	(P11-2)
3	GRN	(P11-3)
4	GRN	(P11-4)
5	GRN	(P11-5)
6	GRN	(P11-6)
7	GRN	(P11-7)
8	GRN	(P11-8)
9	GRN	(P11-9)
10	GRN	(P11-10)
11	GRN	(P11-11)
12	GRN	(P11-12)
13	GRN	(P11-13)
14	GRN	(P11-14)
15	GRN	(P11-15)
16	GRN	(P11-16)
17	GRN	(P11-17)
18	GRN	(P11-18)
19	GRN	(P11-19)
20	GRN	(P11-20)
21	GRN	(P11-21)
22	GRN	(P11-22)
23	GRN	(P11-23)
24	GRN	(P11-24)
25	GRN	(P11-25)
26	GRN	(P11-26)
27	GRN	(P11-27)
28	GRN	(P11-28)
29	GRN	(P11-29)
30	GRN	(P11-30)
31	GRN	(P11-31)
32	GRN	(P11-32)
33	GRN	(P11-33)
34	GRN	(P11-34)

P12 CONNECTIONS

1	GRN	(P12-1)
2	GRN	(P12-2)
3	GRN	(P12-3)
4	GRN	(P12-4)
5	GRN	(P12-5)
6	GRN	(P12-6)
7	GRN	(P12-7)
8	GRN	(P12-8)

REV	DATE	REVISION
1	11-18-14	(A-B & B-1-2) P4 & P11 COLORED LEADS UPDATED TO MATCH CURRENT ENGINE WIRING SCHEMATIC
2	2-24-15	(A-B) P11-B WIRE INCORPORATED AS 6 (CROSSOVER)
3	11-11-15	(A-B) P11-B WIRE INCORPORATED AS 6 (CROSSOVER)
4	11-11-15	(C-2) WIRE INCORPORATED AS 10 (CROSSOVER)
5	11-11-15	(C-4) WIRE INCORPORATED AS 11 (CROSSOVER)
6	11-11-15	(C-4) WIRE INCORPORATED AS 11 (CROSSOVER)
7	11-11-15	(C-4) WIRE INCORPORATED AS 11 (CROSSOVER)
8	11-28-17	(A-3) WIRING TEXT ADDED. SEE SHEET 1 (C171902)

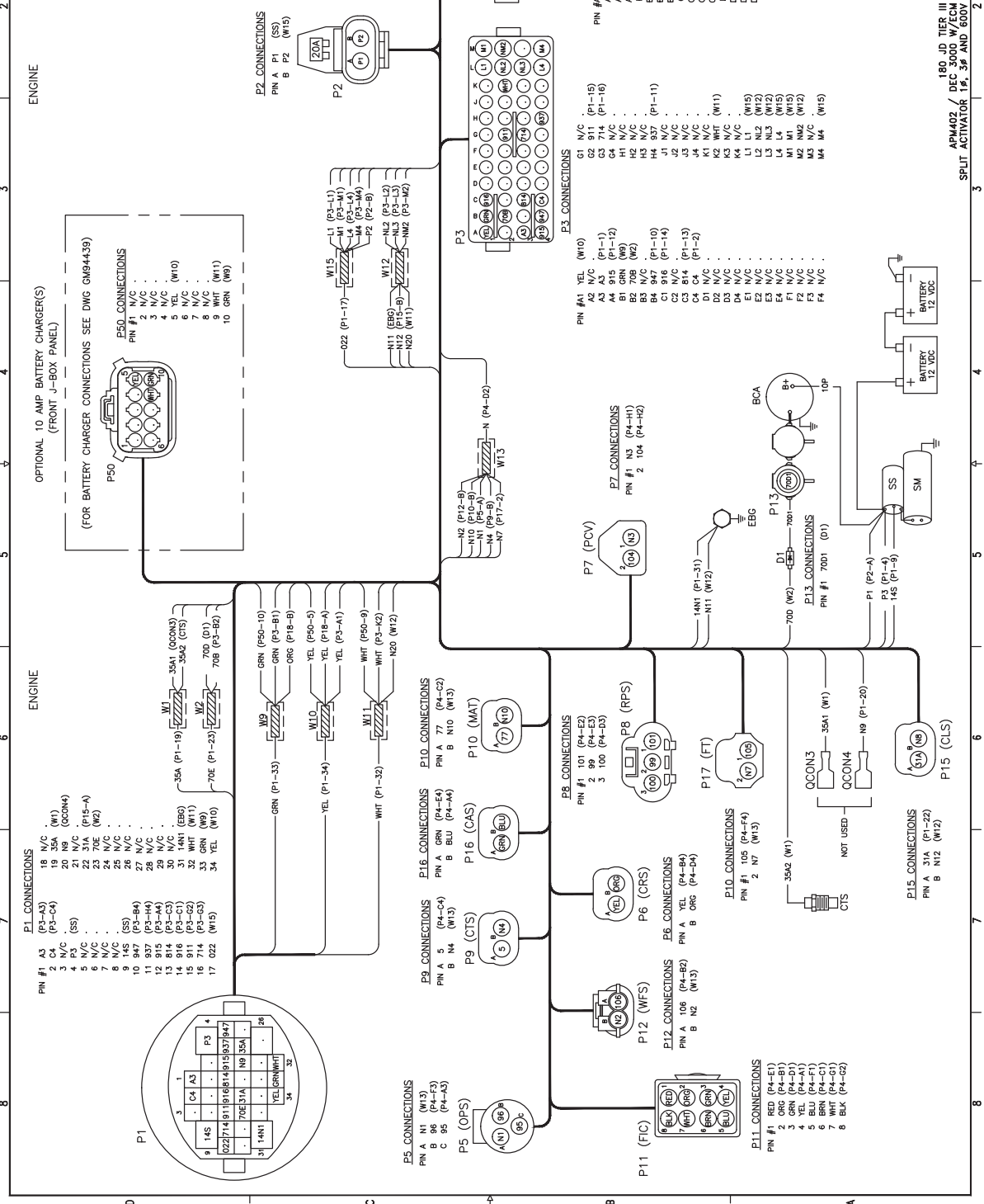

REV	DATE	REVISION
1	11-18-14	(A-B & B-1-2) P4 & P11 COLORED LEADS UPDATED TO MATCH CURRENT ENGINE WIRING SCHEMATIC
2	2-24-15	(A-B) P11-B WIRE INCORPORATED AS 6 (CROSSOVER)
3	11-11-15	(A-B) P11-B WIRE INCORPORATED AS 6 (CROSSOVER)
4	11-11-15	(C-2) WIRE INCORPORATED AS 10 (CROSSOVER)
5	11-11-15	(C-4) WIRE INCORPORATED AS 11 (CROSSOVER)
6	11-11-15	(C-4) WIRE INCORPORATED AS 11 (CROSSOVER)
7	11-11-15	(C-4) WIRE INCORPORATED AS 11 (CROSSOVER)
8	11-28-17	(A-3) WIRING TEXT ADDED. SEE SHEET 1 (C171902)

REV	DATE	REVISION
1	11-18-14	(A-B & B-1-2) P4 & P11 COLORED LEADS UPDATED TO MATCH CURRENT ENGINE WIRING SCHEMATIC
2	2-24-15	(A-B) P11-B WIRE INCORPORATED AS 6 (CROSSOVER)
3	11-11-15	(A-B) P11-B WIRE INCORPORATED AS 6 (CROSSOVER)
4	11-11-15	(C-2) WIRE INCORPORATED AS 10 (CROSSOVER)
5	11-11-15	(C-4) WIRE INCORPORATED AS 11 (CROSSOVER)
6	11-11-15	(C-4) WIRE INCORPORATED AS 11 (CROSSOVER)
7	11-11-15	(C-4) WIRE INCORPORATED AS 11 (CROSSOVER)
8	11-28-17	(A-3) WIRING TEXT ADDED. SEE SHEET 1 (C171902)

180 JD TIER III  
APM402 / DEC 3000 W/ECM  
SPLIT ACTIVATOR 16, 3# AND 600V

180 JD TIER III W/ECM  
GM88841

REV	DATE	DESCRIPTION	BY	CHKD
1	02-10-10	ISSUE FOR INSTALLATION	...	...
2	02-10-10	ISSUE FOR INSTALLATION	...	...
3	02-10-10	ISSUE FOR INSTALLATION	...	...
4	02-10-10	ISSUE FOR INSTALLATION	...	...
5	02-10-10	ISSUE FOR INSTALLATION	...	...
6	02-10-10	ISSUE FOR INSTALLATION	...	...
7	02-10-10	ISSUE FOR INSTALLATION	...	...
8	02-10-10	ISSUE FOR INSTALLATION	...	...

**LEGEND**  
 P( # ) - PLUG  
 Q(OCCON) ( # ) - QUICK CONNECT  
 TB( # ) - TERMINAL BLOCK  
 W( # ) - SONIC WELD

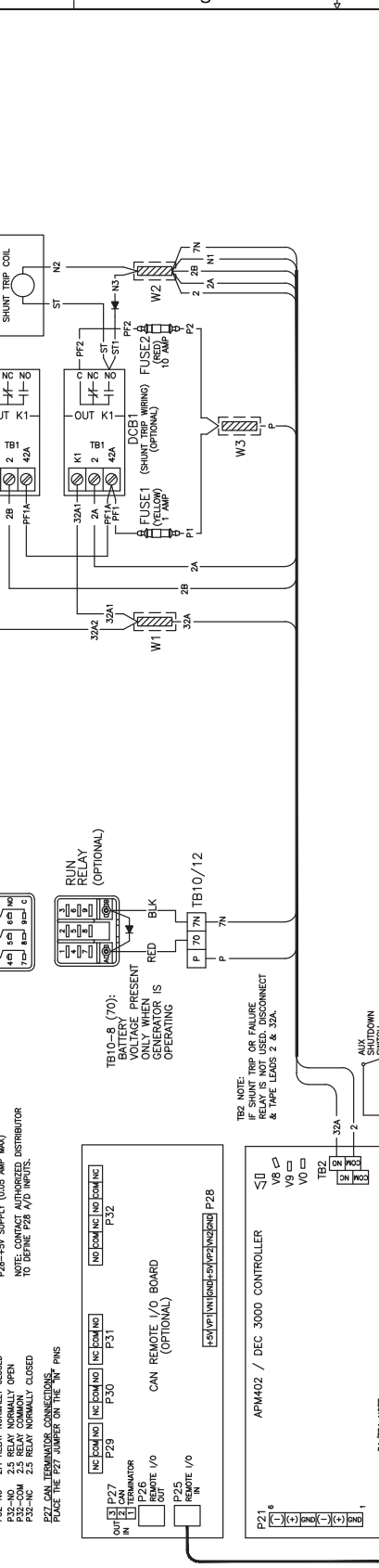

**INSTALLATION NOTES:**  
 1.) FOR FIELD INSTALLATION A MAXIMUM OF TWO WIRE TERMINALS PER TERMINAL STRIP SCREW IS RECOMMENDED UNLESS OTHERWISE NOTED ON THE WIRING DIAGRAM. DO NOT EXTEND ABOVE THE TERMINAL STRIP BARRIER.  
 2.) GENERATOR SETS WITH FUEL TANKS HAVE THE FUEL IN-BASIN SWITCH TIED TO ANALOG INPUT 2 (TB1-A2) VIA P1-23.  
 3.) COOLANT LEVEL SENSOR ON ALL GENSETS IS TIED TO ANALOG INPUT 1 (TB1-A2) VIA P1-24.  
 4.) 40-60 REDZK MODELS HAVE COLD START IGNITION RELAY TIED TO DIGITAL INPUT 2 (TB1-D2)  
 5.) GROUND FAULT WARNING : CONNECT I/O BOARD ON 20REOZK-C.  
 6.) KEYSWITCH AVAILABLE ON SELECT MODELS ONLY.

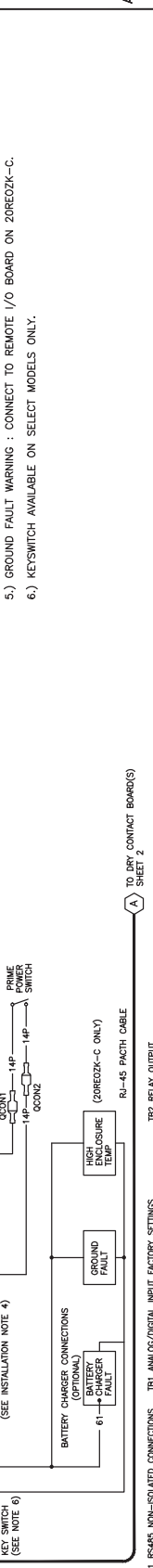

**TB1 NOTE:** TRANSFER SWITCH TERMINAL DESIGNATIONS SHOULD BE IDENTIFIED AND THE CORRECT DESIGNATIONS USING THE APPROPRIATE TRANSFER SWITCH WIRING DIAGRAM.  
 (TERMINALS 3 AND 4. REMOTE EMERGENCY STOP SWITCH CONTACTS ON TRANSFER SWITCH)

**TB2 NOTE:** IF SHUNT TRIP OR FAILURE RELAY IS NOT USED, DISCONNECT & TAPE LEGS 2 & 3A.

**RELAY CONTACTS:** TB10-8 (70): VOLTAGE PRESENT ONLY WHEN MOTOR IS OPERATING

**RELAY CONTACTS:** TB10-12: RED, BLK

**APM402 / DEC 3000 CONTROLLER:** P1-TB1, P2-TB2, P3-TB3, P4-TB4, P5-TB5, P6-TB6, P7-TB7, P8-TB8, P9-TB9, P10-TB10, P11-TB11, P12-TB12, P13-TB13, P14-TB14, P15-TB15, P16-TB16, P17-TB17, P18-TB18, P19-TB19, P20-TB20, P21-TB21, P22-TB22, P23-TB23, P24-TB24, P25-TB25, P26-TB26, P27-TB27, P28-TB28, P29-TB29, P30-TB30, P31-TB31, P32-TB32, P33-TB33, P34-TB34, P35-TB35, P36-TB36, P37-TB37, P38-TB38, P39-TB39, P40-TB40, P41-TB41, P42-TB42, P43-TB43, P44-TB44, P45-TB45, P46-TB46, P47-TB47, P48-TB48, P49-TB49, P50-TB50, P51-TB51, P52-TB52, P53-TB53, P54-TB54, P55-TB55, P56-TB56, P57-TB57, P58-TB58, P59-TB59, P60-TB60, P61-TB61, P62-TB62, P63-TB63, P64-TB64, P65-TB65, P66-TB66, P67-TB67, P68-TB68, P69-TB69, P70-TB70, P71-TB71, P72-TB72, P73-TB73, P74-TB74, P75-TB75, P76-TB76, P77-TB77, P78-TB78, P79-TB79, P80-TB80, P81-TB81, P82-TB82, P83-TB83, P84-TB84, P85-TB85, P86-TB86, P87-TB87, P88-TB88, P89-TB89, P90-TB90, P91-TB91, P92-TB92, P93-TB93, P94-TB94, P95-TB95, P96-TB96, P97-TB97, P98-TB98, P99-TB99, P100-TB100

**APM402 / DEC 3000 CONTROLLER:** P1-TB1, P2-TB2, P3-TB3, P4-TB4, P5-TB5, P6-TB6, P7-TB7, P8-TB8, P9-TB9, P10-TB10, P11-TB11, P12-TB12, P13-TB13, P14-TB14, P15-TB15, P16-TB16, P17-TB17, P18-TB18, P19-TB19, P20-TB20, P21-TB21, P22-TB22, P23-TB23, P24-TB24, P25-TB25, P26-TB26, P27-TB27, P28-TB28, P29-TB29, P30-TB30, P31-TB31, P32-TB32, P33-TB33, P34-TB34, P35-TB35, P36-TB36, P37-TB37, P38-TB38, P39-TB39, P40-TB40, P41-TB41, P42-TB42, P43-TB43, P44-TB44, P45-TB45, P46-TB46, P47-TB47, P48-TB48, P49-TB49, P50-TB50, P51-TB51, P52-TB52, P53-TB53, P54-TB54, P55-TB55, P56-TB56, P57-TB57, P58-TB58, P59-TB59, P60-TB60, P61-TB61, P62-TB62, P63-TB63, P64-TB64, P65-TB65, P66-TB66, P67-TB67, P68-TB68, P69-TB69, P70-TB70, P71-TB71, P72-TB72, P73-TB73, P74-TB74, P75-TB75, P76-TB76, P77-TB77, P78-TB78, P79-TB79, P80-TB80, P81-TB81, P82-TB82, P83-TB83, P84-TB84, P85-TB85, P86-TB86, P87-TB87, P88-TB88, P89-TB89, P90-TB90, P91-TB91, P92-TB92, P93-TB93, P94-TB94, P95-TB95, P96-TB96, P97-TB97, P98-TB98, P99-TB99, P100-TB100

**BATTERY CHARGER CONNECTIONS (OPTIONAL):** BATTERY CHARGER FAULT, GROUND FAULT, HIGH TEMPERATURE FAULT

**RELAY OUTPUTS:** TB2-RELAY OUTPUT (COMMON), TB2-COM (RELAY COMMON), TB2-NO (RELAY NORMALLY OPEN), TB2-NC (RELAY NORMALLY CLOSED)

**APM402 / DEC 3000 CONTROLLER:** P1-TB1, P2-TB2, P3-TB3, P4-TB4, P5-TB5, P6-TB6, P7-TB7, P8-TB8, P9-TB9, P10-TB10, P11-TB11, P12-TB12, P13-TB13, P14-TB14, P15-TB15, P16-TB16, P17-TB17, P18-TB18, P19-TB19, P20-TB20, P21-TB21, P22-TB22, P23-TB23, P24-TB24, P25-TB25, P26-TB26, P27-TB27, P28-TB28, P29-TB29, P30-TB30, P31-TB31, P32-TB32, P33-TB33, P34-TB34, P35-TB35, P36-TB36, P37-TB37, P38-TB38, P39-TB39, P40-TB40, P41-TB41, P42-TB42, P43-TB43, P44-TB44, P45-TB45, P46-TB46, P47-TB47, P48-TB48, P49-TB49, P50-TB50, P51-TB51, P52-TB52, P53-TB53, P54-TB54, P55-TB55, P56-TB56, P57-TB57, P58-TB58, P59-TB59, P60-TB60, P61-TB61, P62-TB62, P63-TB63, P64-TB64, P65-TB65, P66-TB66, P67-TB67, P68-TB68, P69-TB69, P70-TB70, P71-TB71, P72-TB72, P73-TB73, P74-TB74, P75-TB75, P76-TB76, P77-TB77, P78-TB78, P79-TB79, P80-TB80, P81-TB81, P82-TB82, P83-TB83, P84-TB84, P85-TB85, P86-TB86, P87-TB87, P88-TB88, P89-TB89, P90-TB90, P91-TB91, P92-TB92, P93-TB93, P94-TB94, P95-TB95, P96-TB96, P97-TB97, P98-TB98, P99-TB99, P100-TB100

DC POWER REQUIREMENTS FOR EACH RSA:  
 12/24 VOLT, 1A DC POWER  
 IF MULTIPLE RSAs ARE USED, RESIZE  
 2 POWER WIRES AS REQUIRED:  
 0-450 FT. [0-138 m], 22 GA.  
 450-700 FT. [138-214 m], 20 GA.  
 700-1125 FT. [214-344 m], 18 GA.  
 1125-1800 FT. [344-550 m], 16 GA.  
 1800-2800 FT. [550-856 m], 14 GA.  
 (SEE NOTE 4)

GENERATOR SET OUTLINE

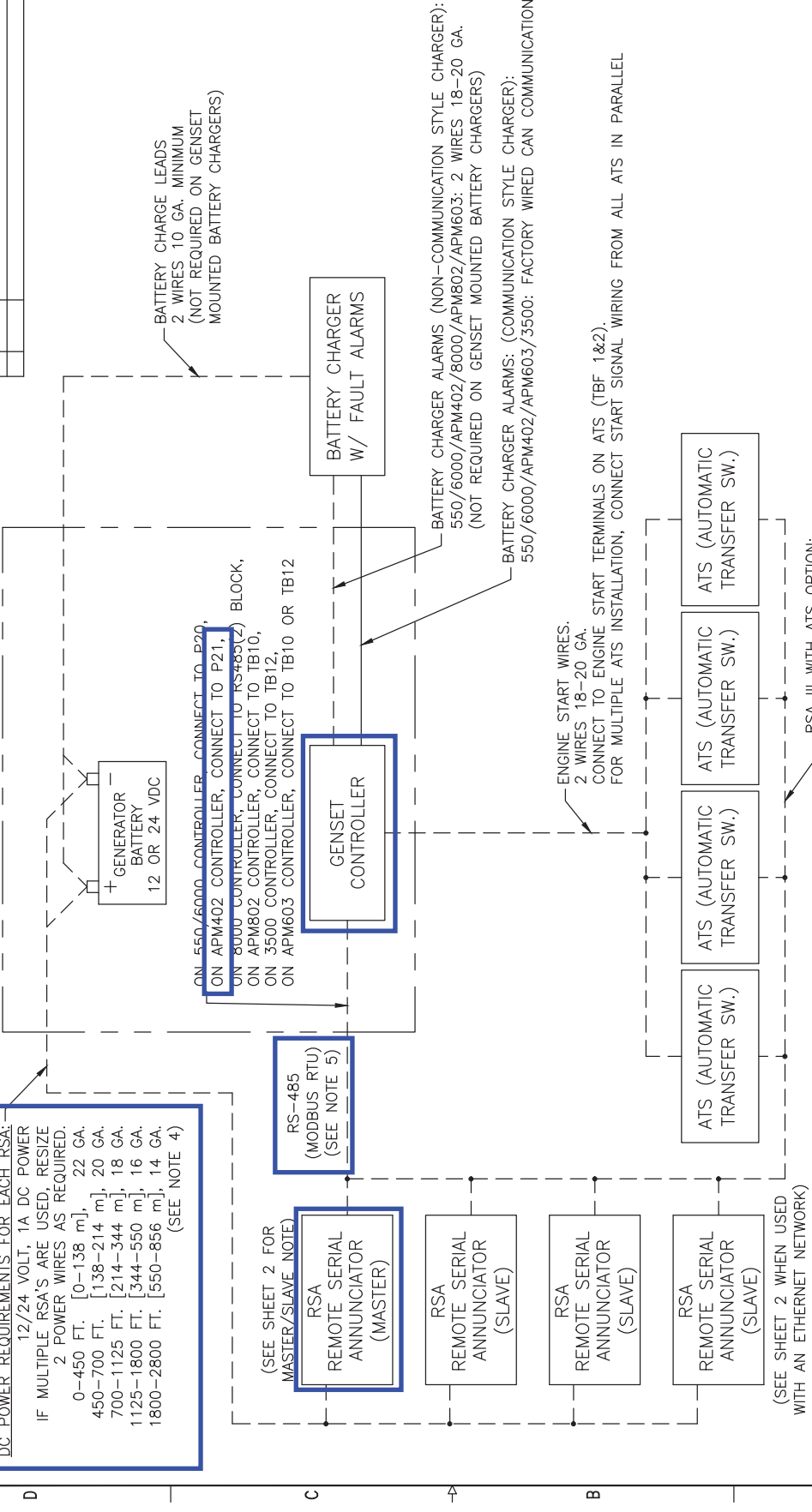

- NOTES:
1. TYPICAL CUSTOMER WIRING SHOWN DASHED.
  2. CUSTOMER RESPONSIBLE FOR ADDITIONAL WIRING SHOWN IF COMPONENTS ARE SHIPPED LOOSE (BATTERY CHARGER, DRY-CONTACT BOX, ETC.)
  3. IF BATTERY CHARGER IS SHIPPED LOOSE ADDITIONAL WIRES MAY BE REQUIRED FOR PROPER VOLTAGE SENSING. REFERENCE DRAWING ADV-5971 FOR INTERCONNECT.
  4. DC VOLTAGE FOR EACH RSA REMOTE ANNUNCIATOR MAY ALSO BE SUPPLIED BY A LOCALLY MOUNTED 12 OR 24 VDC 200 mA MIN. AC ADAPTER KIT (GM62466-KP1).
  5. USE BELDEN #9841 OR EQUIVALENT. MAXIMUM DISTANCE = 4000 FT. [1219 m]

REV	DATE	REVISION	BY	TF
-	8-16-19	NEW DRAWING. REPLACES ADV-6890 [C7198499]		
A	5-27-22	(8-1-3) CONNECT TO ENGINE START TERMINALS ON ATS (TBF 1&2) WAS CONNECT TO POSITION CONTACTS ON ATS (CLOSED IN EMERGENCY); SEE SHEET 2 [C720029]		
				BCC

APPROVALS		DATE	SCALE	SHEET
CHECKED	T.L.K.	8-16-19	///	1-2
APPROVED	M.D.	8-16-19	///	1-2

  

TITLES		DATE	SCALE	SHEET
DESIGNED	T.L.K.	8-16-19	///	1-2
DRAWN	T.L.K.	8-16-19	///	1-2

UNLESS OTHERWISE SPECIFIED:  
 1) DIMENSIONS ARE IN MILLIMETERS  
 2) TOLERANCES ARE:  
 FRACTIONS 2  
 DECIMALS 0.04  
 ANGLES 1/2°  
 HOLE DIA. 0.04  
 THE DRAWING, IN BLOCK AND DETAIL, IS HOLDER CO. PROPERTY AND WILL BE RETURNED TO THE DRAWING OFFICE OF HOLDER CO. WORK ALL RIGHTS OF DESIGN OR INVENTION ARE RESERVED.

ADV-9169

REV	DATE	DESCRIPTION	BY	CHK
AS	10-4-19	SEE SHEET 4 (CT190071)	DS	
AC	10-25-20	SEE SHEET 5 (CT202143)	SRB	
AD	3-30-23	SEE SHEETS 4, 6 & 8 (CT226554)	SRB	
AE	11-4-23	SEE SHEET 6 (CT231345)	SRB	

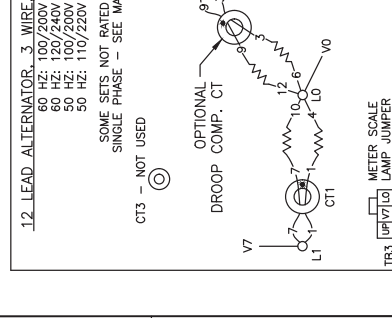
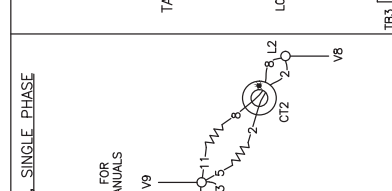
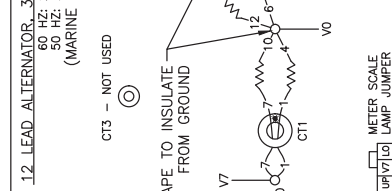
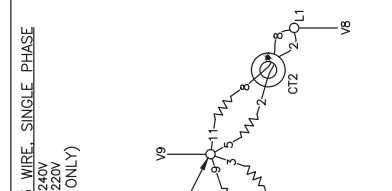
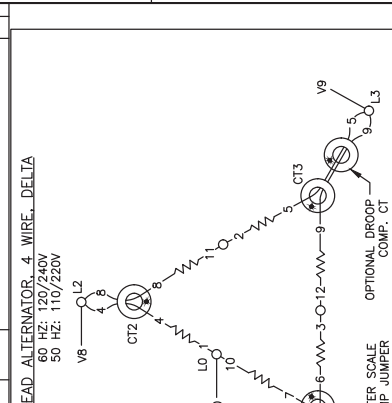

REVISIONS	DATE	DESCRIPTION	BY	CHK
1	10-4-19	SEE SHEET 4 (CT190071)	DS	
2	10-25-20	SEE SHEET 5 (CT202143)	SRB	
3	3-30-23	SEE SHEETS 4, 6 & 8 (CT226554)	SRB	
4	11-4-23	SEE SHEET 6 (CT231345)	SRB	

UNDER ENGINEERING APPROVAL - 3 TO 10 DAYS DATE APPROVED BY DATE APPROVED BY	U.S.A. POWER SYSTEMS THIS COMPANY IS AN EQUAL OPPORTUNITY AND AFFIRMATIVE ACTION EMPLOYER. THE QUALITY OF SERVICE IS OUR TOP PRIORITY.
--	--

DATE APPROVED BY DATE APPROVED BY	U.S.A. POWER SYSTEMS THIS COMPANY IS AN EQUAL OPPORTUNITY AND AFFIRMATIVE ACTION EMPLOYER. THE QUALITY OF SERVICE IS OUR TOP PRIORITY.
--	--

DATE APPROVED BY DATE APPROVED BY	U.S.A. POWER SYSTEMS THIS COMPANY IS AN EQUAL OPPORTUNITY AND AFFIRMATIVE ACTION EMPLOYER. THE QUALITY OF SERVICE IS OUR TOP PRIORITY.
--	--

DATE APPROVED BY DATE APPROVED BY	U.S.A. POWER SYSTEMS THIS COMPANY IS AN EQUAL OPPORTUNITY AND AFFIRMATIVE ACTION EMPLOYER. THE QUALITY OF SERVICE IS OUR TOP PRIORITY.
--	--

DATE APPROVED BY DATE APPROVED BY	U.S.A. POWER SYSTEMS THIS COMPANY IS AN EQUAL OPPORTUNITY AND AFFIRMATIVE ACTION EMPLOYER. THE QUALITY OF SERVICE IS OUR TOP PRIORITY.
--	--

NOTES:  
 CURRENT TRANSFORMER DOT OR "H1" TOWARD GENERATOR.  
 CURRENT TRANSFORMERS NOT USED ON ALL SETS.  
 SOME STATORS HAVE DUAL LEADS. ALWAYS CONNECT LEADS OF THE SAME LABEL TOGETHER.

PHASE ROTATION  
 A B C  
 L1 L2 L3

60 (I.M.S.)-300 KW WOUND EXCITER FIELD  
 600V FRII  
 ALTERNATORS

ADV-5875

**KOHLER®**

# Miscellaneous

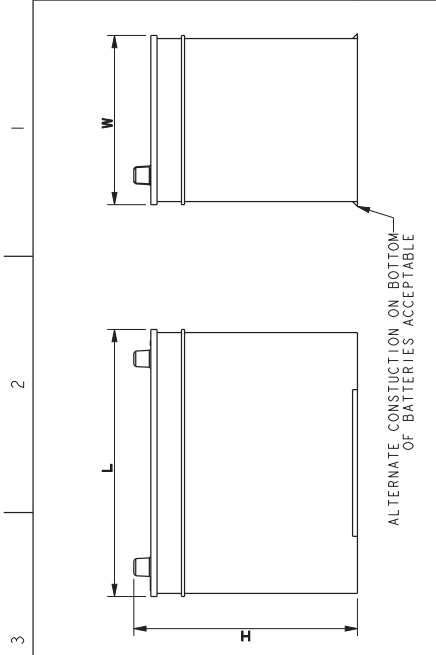

ALTERNATE CONSTRUCTION ON BOTTOM OF BATTERIES ACCEPTABLE

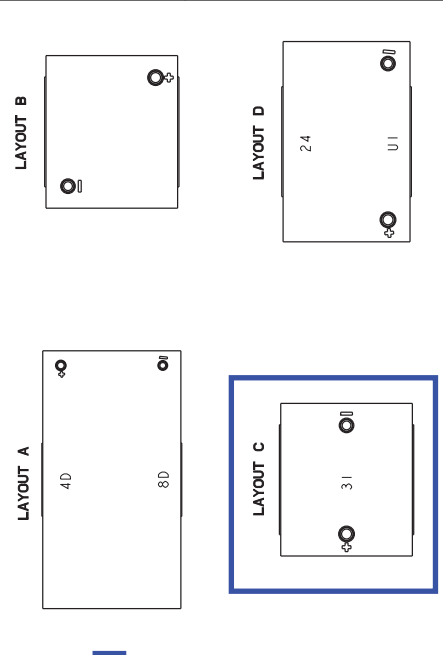

PART NO.	REV	SAE DIMENSION			VOLTAGE	COLD CRANKING AMPS AT 0°F MINIMUM	RESERVE CAP MINUTES AT 80°F MINIMUM	POST LAYOUT /STYLE	CHARGE TYPE	BATTERY CONSTRUCTION (SEE SHEET 2)	BCI GROUP	INTERNAL RESISTANCE (MΩ)
		L	W	H								
244678	0F	333.5 [13.13]	181.1 [7.13]	238.5 [9.39]	6	700	275	D/1	DRY	SEE NOTE 1	-	
244750	0D	342.9 [13.50]	173.2 [6.82]	238.3 [9.38]	12	600	165	D/1	DRY	SEE NOTE 1	-	
239802	0K	330.2 [13.00]	133.4 [5.25]	187.5 [7.38]	12	200	32	D/2	DRY	SEE NOTE 1	-	
239816	0C	539.0 [21.21]	202.7 [8.00]	276.4 [10.88]	12	1150	450	A/1	DRY	SEE NOTE 1	-	
239198	0C	333.2 [13.12]	173.0 [6.81]	239.8 [9.44]	12	700	150	C/3	WET	SEE NOTE 1	-	
254425	0D	333.2 [13.12]	173.0 [6.81]	239.8 [9.44]	12	700	150	C/3	DRY	SEE NOTE 1	-	
254425	0D	333.2 [13.12]	173.0 [6.81]	239.8 [9.44]	12	700	200	C/3	WET	SEE NOTE 1	-	
254425	0C	333.2 [13.12]	173.0 [6.81]	239.8 [9.44]	12	950	200	C/3	DRY	SEE NOTE 1	-	
324387	0M	208.0 [8.19]	173.4 [6.83]	136.9 [5.39]	12	675	90	C/1	WET	SEE NOTE 1	-	
324388	0C	208.0 [8.19]	166.9 [6.57]	205.2 [8.08]	12	675	90	C/1	DRY	SEE NOTE 1	-	
324866	0U	330.2 [13.00]	173.0 [6.81]	239.8 [9.44]	12	950	185	C/3	WET	SEE NOTE 2	31	
324867	0U	330.2 [13.00]	173.0 [6.81]	239.8 [9.44]	12	950	200	C/3	DRY	SEE NOTE 2	31	
266984	0T	273.0 [10.75]	173.0 [6.81]	228.6 [9.00]	12	650	130	D/1	WET	SEE NOTE 1	24E	
225289	0T	273.0 [10.75]	173.0 [6.81]	228.6 [9.00]	12	650	130	D/1	DRY	SEE NOTE 1	24E	
345187	0S	273.0 [10.75]	173.0 [6.81]	228.6 [9.00]	12	510	80	C/1	WET	SEE NOTE 2	24F	
354147	0T	330.2 [13.00]	173.0 [6.81]	239.8 [9.44]	12	700	170	C/3	WET	SEE NOTE 2	31	
354148	0U	330.2 [13.00]	173.0 [6.81]	239.8 [9.44]	12	700	150	C/3	DRY	SEE NOTE 2	31	
345309	0R	219.2 [8.63]	153.9 [6.06]	212.9 [8.38]	12	525	-	E/1	WET	SEE NOTE 1	55	
GM223468	0C	525.3 [20.68]	220.5 [8.68]	251.0 [9.88]	12	1400	320	A/1	DRY	SEE NOTE 1	-	
GM223468	0T	527.1 [20.75]	202.4 [8.00]	276.4 [10.88]	12	1150	400	A/1	DRY	SEE NOTE 1	RD	
GM34399	0T	527.1 [20.75]	202.4 [8.00]	276.4 [10.88]	12	1400	430	A/1	WET	SEE NOTE 1	RD	
GM46784	0T	208.0 [8.19]	173.0 [6.81]	136.9 [5.39]	12	525	70	D/1	WET	SEE NOTE 1	24E	
GM7582	0T	238.0 [9.37]	179.0 [7.05]	223.0 [8.81]	12	500	85	D/1	WET	SEE NOTE 1	51F	
1070200701	A	527.1 [20.75]	216.0 [8.50]	258.0 [10.16]	12	1050	290	A/1	WET	SEE NOTE 3	4D	
1070200800	A	527.1 [20.75]	216.0 [8.50]	254.0 [10.00]	12	1110	380	A/1	AGM	SEE NOTE 3	4D	
GM06681	-	260.0 [10.24]	171.0 [6.73]	208.0 [8.19]	12	690	105	D/1	WET	SEE NOTE 3	34	
GM06375	-	330.2 [13.00]	171.0 [6.73]	239.8 [9.44]	12	925	180	C/3	WET	SEE NOTE 2	31	
GM06373	-	260.0 [10.24]	171.0 [6.73]	229.0 [9.00]	12	650	95	D/1	WET	SEE NOTE 1	24	
GM06377	-	527.1 [20.75]	279.0 [11.00]	254.0 [10.00]	12	1400	380	A/1	WET	SEE NOTE 1	80	
GM06369	-	208.0 [8.19]	172.0 [6.77]	200.0 [7.87]	12	500	95	D/1	WET	SEE NOTE 1	26	
GM06374	-	237.0 [9.32]	125.0 [4.94]	220.0 [8.66]	12	500	70	D/1	WET	SEE NOTE 1	51	
GM17040	-	286.0 [11.25]	171.0 [6.73]	238.0 [9.37]	12	750	140	D/3	AGM	SEE NOTE 3	24	
GM17041	-	330.2 [13.00]	172.0 [6.77]	241.0 [9.48]	12	950	185	C/3	AGM	SEE NOTE 3	31	
GM17042	-	520.0 [20.47]	269.0 [10.59]	238.0 [9.37]	12	1450	480	A/1	AGM	SEE NOTE 3	8D	

NOTE:  
 DIMENSIONS IN [ ] ARE ENGLISH EQUIVALENTS.  
 THIS ASSEMBLY OR PART MUST COMPLY WITH PEP-RML-001.  
 □ INDICATES PART NUMBERS AFFECTED BY LATEST DRAWING REVISION

8 7 6 5 4 3 2 1

REV	DATE	ON COMPOSITE DIMS. SEE PART NO. FOR REVISION LEVEL	BY	DO NOT SCALE. REFERENCE THE MODEL FOR ALL UNSPECIFIED DIMENSIONS
CA	4-15-19	(C-8) GM10688; GM106335; GM106373; GM106377.		UNLESS OTHERWISE SPECIFIED, DIMENSIONS ARE IN MILLIMETERS.
		GM106369 & GM106374 ADDED; (D-3) INTERNAL RESISTANCE (MΩ) COLUMN ADDED; (D-8) 324586 & 256884. VOIDED; (C-8) GM44399; GM48784; GM1512 VOIDED; (A-B-8, 1, 6, 5, 4) VIEWS & NOTES MOVED TO SHEET 2. SHEET 2 ADDED (CT194425)		MAX. SURFACE FINISH: 2.5 μm (0.10 mil) MAX. SURFACE FINISH: 1.6 μm (0.06 mil) MAX. SURFACE FINISH: 0.8 μm (0.03 mil)
CB	25MAY2021	(B-8) GM117040; GM117041 & GM117042 ADDED.		APPROVALS: DATE
		PEP-RML-001 - NOTE ADDED (PROB8852)		DESIGNER: SLR 4-15-19
CC	3 JUL 2021	(CT19-8) 22589; 324587 & GM22349 VOIDED (CT172924)		CHECKER: CB 4-15-19
CD	21 JAN 2023	SEE SHEET 2 (CT23049)		APPROVED: RPD 4-15-19

**KOHLER**  
 THIS DRAWING IS THE PROPERTY OF KOHLER. IT IS TO BE USED ONLY FOR THE DESIGN OR INVENTION SPECIFIED HEREIN. ALL RIGHTS ARE RESERVED.

SCALE: 0.30 (CAR NO.)  
**244578-CMP**

SHEET 1 OF 2

8 7 6 5 4 3 2 1

8 7 6 5 4 3 2 1

**STYLE 1**

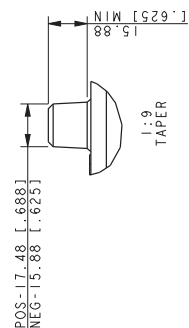

**STYLE 2**

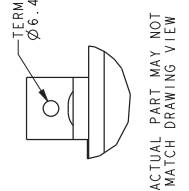

**STYLE 3**

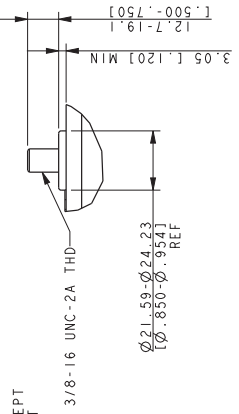

NOTES:  
 1) STYLE 3 CAN BE CONVERTED TO STYLE 1 BY INSTALLATION OF 254427 STUD CONVERSION KIT.  
 2) STYLE 3 TERMINAL STUDS MUST HAVE EITHER THE "POS." OR "NEG." STUD CLEARLY IDENTIFIED.  
 3) STYLE TERMINAL TORQUE TO MATCH FULL SIZE STUDS.  
 4) "POS." & "NEG." IDENTIFICATION MUST BE MARKED AS SHOWN ON THE PART LAYOUT AND WITHIN 5mm OF THE STUD.

**NOTES:**

- (APPLIES TO ALL BATTERIES)  
 SAE J537 DIMENSIONS ARE MAX ALLOWABLE DIMENSIONS.  
 COLD CRANKING AMPS ARE MINIMUM ACCEPTABLE VALUES.  
 HOLD DOWN DESIGN IN COMPLIANCE WITH SAE STANDARDS.  
 BATTERY WARNING LABEL TO BE LOCATED ON TOP OF BATTERY. (BETWEEN TERMINALS ON LAYOUT D)  
 MANUFACTURE PART NUMBER OR CERTIFICATE NUMBER TO BE LOCATED ON BATTERY WAREHOUSE LABEL.  
 SEE N.F.P.A. 110 FOR SPECIFIC DETAILS. CERTIFICATE REQUIRED ONLY ONCE PER BATTERY PART NUMBER.  
 MAY NOT BE CALCIUM-CALCIUM TYPE.
- (CHARGE TYPE)  
 ALL DRY CHARGED BATTERIES MUST BE SUPPLIED WITH ACTIVATION INSTRUCTIONS ADHERED TO BATTERY AND LOOSE. BATTERY MUST ALSO BE IDENTIFIED ON TOP AS: "DRY CHARGED. MUST ADD BATTERY GRADE ELECTROLYTE. SEE ACTIVATION INSTRUCTIONS."  
 BATTERIES SHOULD BE RECEIVED APPROPRIATELY MARKED AS DRY CHARGED OR WET STORAGE.  
 ONE OF THE BATTERY POSTS MUST BE SHIELDED WHEN BATTERIES ARE WET CHARGED.  
 BATTERIES WHEN SHIPPED DRY - DO NOT REQUIRE POST PROTECTORS.
- (BATTERY CONSTRUCTION)  
 1) MUST BE LEAD-CALCIUM HYBRID OR LEAD-ANTIMONY TYPE.  
 2) LEAD-CALCIUM GRID.  
 3) ABSORBED GLASS MAT. (AGM)

REV#	DATE	ON COMPOSITE DIMS. SEE PART NO. FOR REVISION LEVEL	BY	DO NOT SCALE. REFERENCE THE MODEL FOR ALL UNSPECIFIED DIMENSIONS												
CA	4-15-19	NEW DRAWING: SEE SHEET 1 (CT194425)	DS	UNLESS OTHERWISE SPECIFIED, TOLERANCES ARE: FRACTIONAL DIMENSIONS: FRACTIONAL DIMENSIONS: .005 DECIMAL DIMENSIONS: .005 DIMENSIONS IN PARENTHESES: DIMENSIONS IN PARENTHESES: .005												
CB	25MAY2021	SEE SHEET 1 (PR09852)	PAR	THIS DRAWING IN DESIGN AND DETAIL IS KOHLER PROPERTY AND MUST NOT BE REPRODUCED OR COPIED FOR ANY PURPOSES WITHOUT THE WRITTEN PERMISSION OF KOHLER. THIS DRAWING IS THE PROPERTY OF KOHLER. ALL RIGHTS ARE RESERVED.												
CC	23JUL2021	SEE SHEET 1 (CT212924)	PAR	THIS DRAWING IS THE PROPERTY OF KOHLER. ALL RIGHTS ARE RESERVED.												
CD	31JAN2023	IC-8 NOTE 1 UPDATED (CT225049)	PAR	THIS DRAWING IS THE PROPERTY OF KOHLER. ALL RIGHTS ARE RESERVED.												
<table border="1"> <thead> <tr> <th>APPROVALS</th> <th>DATE</th> <th>TITLE</th> </tr> </thead> <tbody> <tr> <td>DESIGNED</td> <td>4-15-19</td> <td>DS</td> </tr> <tr> <td>CHECKED</td> <td>4-15-19</td> <td>GR</td> </tr> <tr> <td>APPROVED</td> <td>4-15-19</td> <td>AMM</td> </tr> </tbody> </table>					APPROVALS	DATE	TITLE	DESIGNED	4-15-19	DS	CHECKED	4-15-19	GR	APPROVED	4-15-19	AMM
APPROVALS	DATE	TITLE														
DESIGNED	4-15-19	DS														
CHECKED	4-15-19	GR														
APPROVED	4-15-19	AMM														
DWG. BATTERY SHEET 2 OF 2 244578-CMP																



8 7 6 5 4 3 2 1

KIT NO.	ITEM	PART NO.	QTY	DESCRIPTION
GM103794-KA1	1	GM103784	1	BATTERY HEATER 120V., 80W
	2	X-468-1	2	HEATER, BATTERY WRAP 120V., 80W TIE, CABLE

THIS IS AN AUTOMATED TABLE. ALL UPDATES MUST BE MADE IN THE ASSEMBLY.

GM103794-KA1 SHOWN  
TANK MOUNTED BATTERY BOX

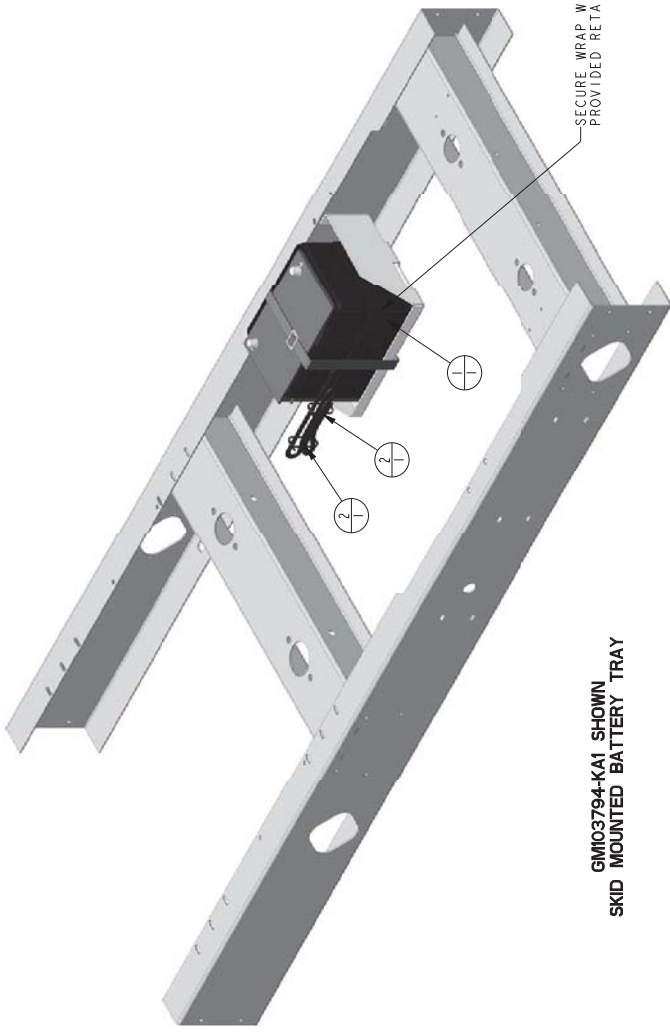
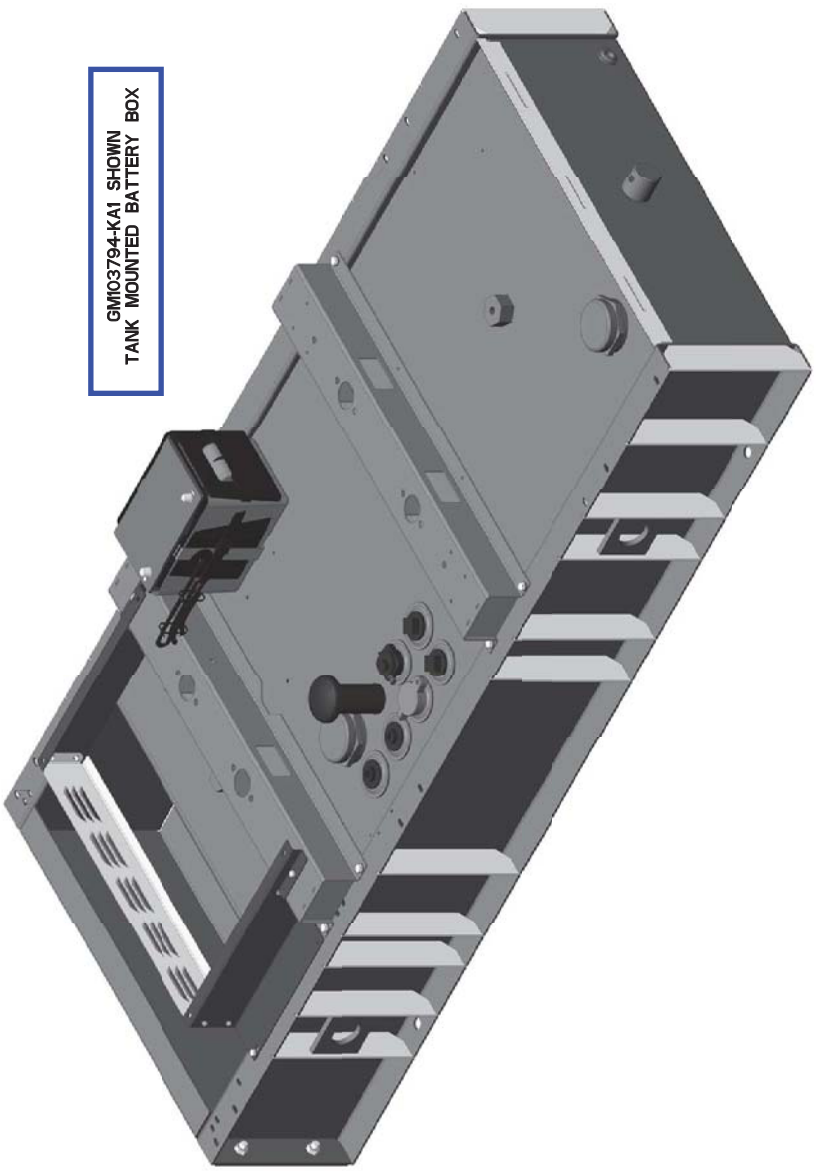

GM103794-KA1 SHOWN  
SKID MOUNTED BATTERY TRAY

NOTES:  
BATTERY NOT INCLUDED WITH KITS. REFERENCE IN DRAWING VIEWS ONLY.  
SECURE CORD FROM EACH BATTERY HEATER WRAP WITH (2) CABLE TIES.

REV.	DATE	ON COMPOSITE DIMS. SEE PART NO. FOR REVISION LEVEL	BY	DO NOT SCALE. REFERENCE THE MODEL FOR ALL UNSPECIFIED DIMENSIONS
-	8-15-17	NEW DRAWING: LC11769901	GFR	UNLESS OTHERWISE SPECIFIED, TOLERANCES SHALL BE: FRACTIONS: 1/16" SURFACE FINISH: 125 DECIMALS: 0.005 SURFACE FINISH: 32 ANGLES: 0.031" MAX.

APPROVALS	DATE	TITLE
DESIGNED	8-15-17	DWG. BATTERY WRAP HEATER
CHECKED	8-15-17	
APPROVED	8-28-17	

SCALE	0.20 (1:4)
SHEET	1 OF 4
PART NO.	GM103794

D C B A

KIT NUMBER	VIEW	DESCRIPTION
GM94447-KAI	VIEW 1&3	BATTERY CHARGER, FLOAT 12V/24V 10A
GM94447-KAZ	VIEW 2	BATTERY CHARGER, FLOAT 24V 10A

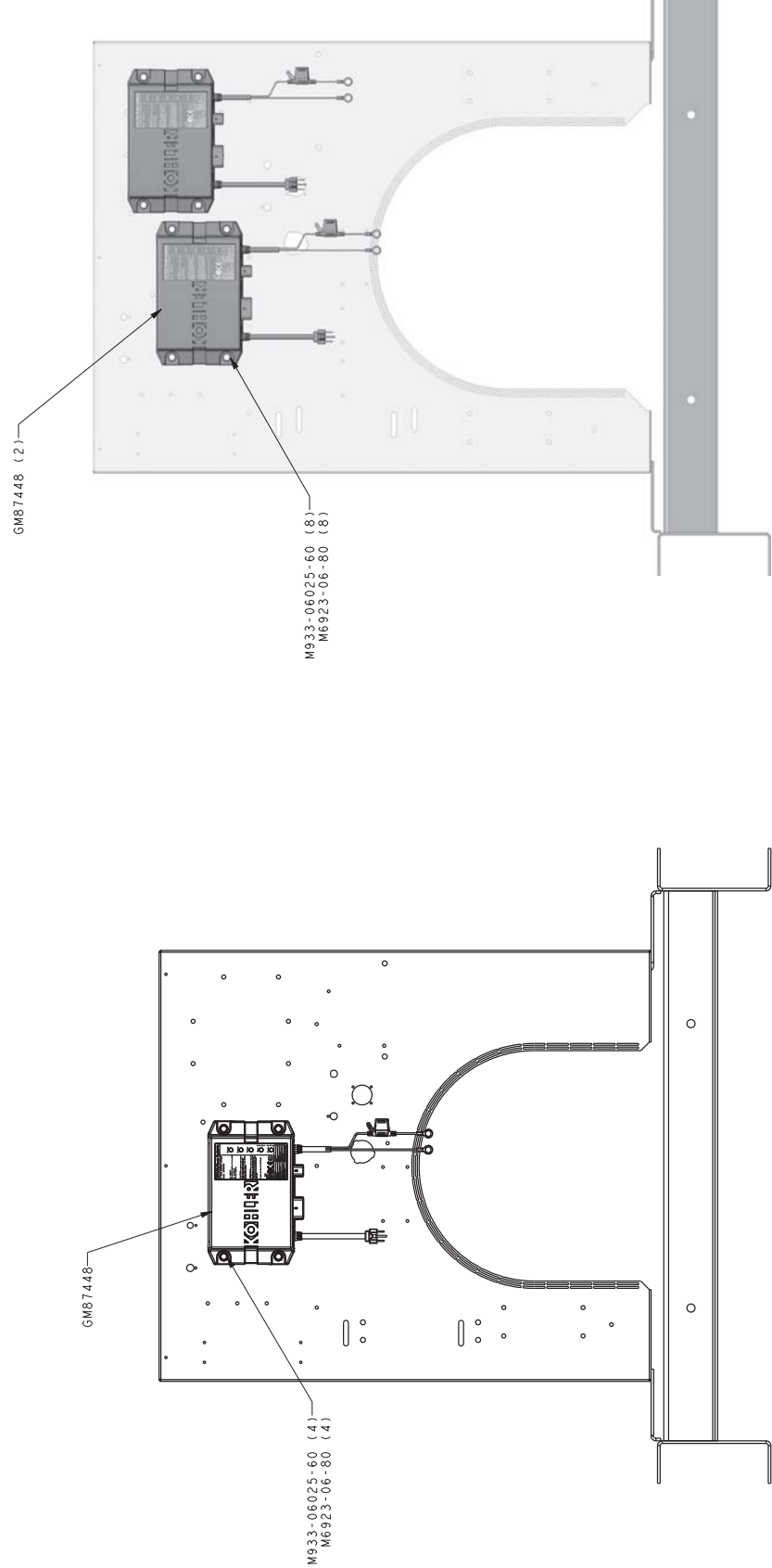

**VIEW 1**

**VIEW 2**

NOTE:  
FOR PROPER ASSEMBLY METHOD OF HARDWARE, USE G-585 AS A GUIDELINE.  
THIS ASSEMBLY OR PART MUST COMPLY WITH PEP-RML-001

REV	DATE	ON COMPOSITE DWGS. SEE PART NO. FOR REVISION LEVEL	BY	UNLESS OTHERWISE SPECIFIED, DIMENSIONS ARE IN MILLIMETERS	SCALE	PROJ.	METRIC	PROJ.
-	9-23-14	NEW DRAWING [CT194502]	SAW	2.0	1:1	0.0000	MM	0.0000
A	2-16-18	SHEET 2 ADDED: SEE SHEET 2 [CT184382]	KRM	2.0	1:1	0.0000	MM	0.0000
B	04MAY2022	ID-7: GM94447-KAI DESCRIPTION UPDATED. (A-3) *PEP-RML-001* NOTE ADDED [CT219524]	PBC	2.0	1:1	0.0000	MM	0.0000

APPROVALS	DATE	SCALE	CR.
SAW	9-23-14	0.40	0.40
KRM	9-23-14		
PBC	04MAY2022		

<b>DWG. ASSY BATTERY CHARGER</b>	
DATE	9-23-14
SCALE	0.40
APPNO	ACT 19-23-14
APPNO	ACT 19-23-14

GM874418

M933-06025-60 (4)  
M6923-06-80 (4)

CONNECT TO BATTERY

VIEW 3

REV	DATE	DESCRIPTION	BY	APPROVALS	DATE	SCALE	SHEET NO.	TOTAL SHEETS
A	2-16-18	VIEW 3 ADDED (CT184382)	ARM		2-15-18	0.25	1	2
B	24MAY2023	SEE SHEET 1 (CT18524)	PBC		2-15-18		2	2

APPROVALS	DATE	SCALE	SHEET NO.	TOTAL SHEETS

BY	DATE	DESCRIPTION
ARM	2-15-18	INITIALS
PBC	24MAY2023	INITIALS

UNLESS OTHERWISE SPECIFIED, THIS DRAWING IS THE PROPERTY OF KOHLER CO. THIS DRAWING IS NOT TO BE REPRODUCED OR TRANSMITTED IN ANY FORM OR BY ANY MEANS, ELECTRONIC OR MECHANICAL, INCLUDING PHOTOCOPYING, RECORDING, OR BY ANY INFORMATION STORAGE AND RETRIEVAL SYSTEM. ALL RIGHTS OF DESIGN OR INVENTION ARE RESERVED.

**KOHLER CO.** METRIC PROE  
 1000 KOHLER DRIVE, STURIS, OH 44224, U.S.A.  
 THIS DRAWING IS THE PROPERTY OF KOHLER CO. THIS DRAWING IS NOT TO BE REPRODUCED OR TRANSMITTED IN ANY FORM OR BY ANY MEANS, ELECTRONIC OR MECHANICAL, INCLUDING PHOTOCOPYING, RECORDING, OR BY ANY INFORMATION STORAGE AND RETRIEVAL SYSTEM. ALL RIGHTS OF DESIGN OR INVENTION ARE RESERVED.

**DWG. ASSY BATTERY CHARGER**  
 SCALE: 0.25 (CR. NO.)  
 SHEET 2 OF 2

GM94447  
 SHEET 2 OF 2



PART NO.	REV	VOLTS	WATTS	AMPS	THERMOSTAT TYPE/STYLE	REMOTE SENSOR TEMP. RANGE	TANK SENSOR TEMP. RANGE	THREAD SIZE "A"	PLUG CONFIG.	LENGTH "B"	CORD TYPE	REMARKS
324930	W	120	1800	15.0	IN BLOCK/B	38°/49° C [100°/120° F]	49°/60° C [120°/140° F]	1/2 NPT	FIG-2	1575 [62.0]	1	
324931	W	240	2000	8.3	IN BLOCK/B	38°/49° C [100°/120° F]	49°/60° C [120°/140° F]	1/2 NPT	FIG-3	1575 [62.0]	1	
326220	W	120	1000	8.3	IN BLOCK/A	38°/49° C [100°/120° F]	49°/60° C [120°/140° F]	5/8-18 UNF 2A	FIG-1	1372 [54.0]	1	
326221	W	240	1000	4.2	IN BLOCK/A	38°/49° C [100°/120° F]	49°/60° C [120°/140° F]	5/8-18 UNF 2A	FIG-1	1372 [54.0]	1	
326222	Z	240	1000	4.2	IN HOSE/C	27°/38° C [80°/100° F]	38°/49° C [100°/120° F]	-	FIG-1	1372 [54.0]	1	
326223	W	120	1500	12.5	IN BLOCK/A	38°/49° C [100°/120° F]	49°/60° C [120°/140° F]	1/2 NPT	FIG-1	1372 [54.0]	1	
326224	W	240	1500	6.3	IN BLOCK/A	38°/49° C [100°/120° F]	49°/60° C [120°/140° F]	1/2 NPT	FIG-2	1372 [54.0]	1	
326225	W	120	1800	15.0	IN BLOCK/A	38°/49° C [100°/120° F]	49°/60° C [120°/140° F]	1/2 NPT	FIG-3	1575 [62.0]	1	
326234	W	240	2000	8.3	IN BLOCK/A	38°/49° C [100°/120° F]	49°/60° C [120°/140° F]	1/2 NPT	FIG-3	1575 [62.0]	1	
326235	W	240	2000	8.3	IN BLOCK/A	38°/49° C [100°/120° F]	49°/60° C [120°/140° F]	1/2 NPT	FIG-3	1575 [62.0]	1	
326247	W	120	1500	12.5	IN BLOCK/A	38°/49° C [100°/120° F]	49°/60° C [120°/140° F]	5/8-18 UNF 2A	FIG-1	1372 [54.0]	1	
326248	W	240	1500	6.3	IN BLOCK/A	38°/49° C [100°/120° F]	49°/60° C [120°/140° F]	5/8-18 UNF 2A	FIG-3	1372 [54.0]	1	
336703	W	120	1500	12.5	IN HOSE/C	16°/27° C [60°/80° F]	38°/49° C [100°/120° F]	-	FIG-1	1372 [54.0]	1	
352945	Y	120	1500	12.5	-	27°/38° C [80°/100° F]	-	-	FIG-1	1524 [60.0]	2	IN-BASE SENSING UNIT ONLY
ES-89230	W	120	1500	12.5	-	38°/49° C [100°/120° F]	-	-	FIG-1	1524 [60.0]	1	IN-BASE SENSING UNIT ONLY
32946	W	240	1500	6.3	-	27°/38° C [80°/100° F]	-	-	FIG-3	1219 [48.0]	2	IN-BASE SENSING UNIT ONLY
358311	Y	120	1000	8.3	-	27°/38° C [80°/100° F]	-	-	FIG-1	-	2	IN-BASE SENSING UNIT ONLY
358327	W	240	1000	4.2	-	27°/38° C [80°/100° F]	-	-	FIG-3	-	2	IN-BASE SENSING UNIT ONLY
GM23005	W	120	1800	15.0	IN BLOCK/D	27°/38° C [80°/100° F]	49°/60° C [120°/140° F]	28-1.25 6g METRIC	FIG-2	762 [30.0]	1	
GM23006	W	240	2000	8.3	IN BLOCK/D	27°/38° C [80°/100° F]	49°/60° C [120°/140° F]	28-1.25 6g METRIC	FIG-3	762 [30.0]	1	
GM24947	W	240	2000	8.3	IN BLOCK/A	38°/49° C [100°/120° F]	49°/60° C [120°/140° F]	MI-4-1.5 METRIC	FIG-3	1575 [62.0]	1	
GM24948	W	120	1800	15.0	IN BLOCK/A	38°/49° C [100°/120° F]	49°/60° C [120°/140° F]	MI-4-1.5 METRIC	FIG-2	1575 [62.0]	1	
GM28585	Y	120	1000	8.3	-	27°/38° C [80°/100° F]	-	-	FIG-1	-	2	CORD THERMOSTAT [40°/60° F]
GM31942	Y	120	1000	8.3	IN BLOCK/A	27°/38° C [80°/100° F]	49°/60° C [120°/140° F]	1/2 NPT	FIG-1	1372 [54.0]	1	
GM31943	Y	240	1000	4.2	IN BLOCK/A	27°/38° C [80°/100° F]	49°/60° C [120°/140° F]	1/2 NPT	FIG-3	1372 [54.0]	1	
GM62682	Y	120	1000	8.3	-	27°/38° C [80°/100° F]	-	-	FIG-4	-	3	
GM75552	AA	120	1800	15.0	-	27°/38° C [80°/100° F]	-	-	FIG-2	-	2	IN-BASE SENSING UNIT ONLY
GM75553	AA	240	2000	8.3	-	27°/38° C [80°/100° F]	-	-	FIG-3	-	2	IN-BASE SENSING UNIT ONLY
GM83980	AD	120	1000	8.3	-	16°/27° C [60°/80° F]	-	-	FIG-1	1524 [60.0]	2	IN-BASE SENSING UNIT ONLY INCLUDES THERMOSTAT TEMPERATURE DECAL
GM83981	AB	120	1500	12.5	-	16°/27° C [60°/80° F]	-	-	FIG-1	1219 [48.0]	2	IN-BASE SENSING UNIT ONLY INCLUDES THERMOSTAT TEMPERATURE DECAL
GM95436	-	120	500	4.2	-	27°/38° C [80°/100° F]	-	-	FIG-1	-	2	IN-BASE SENSING UNIT ONLY
GM95437	-	240	500	2.1	-	27°/38° C [80°/100° F]	-	-	FIG-3	-	2	IN-BASE SENSING UNIT ONLY
GM103846	-	120	1800	15.0	-	16°/27° C [60°/80° F]	-	-	FIG-2	-	2	IN-BASE SENSING UNIT ONLY

THIS IS AN MANUAL TABLE.

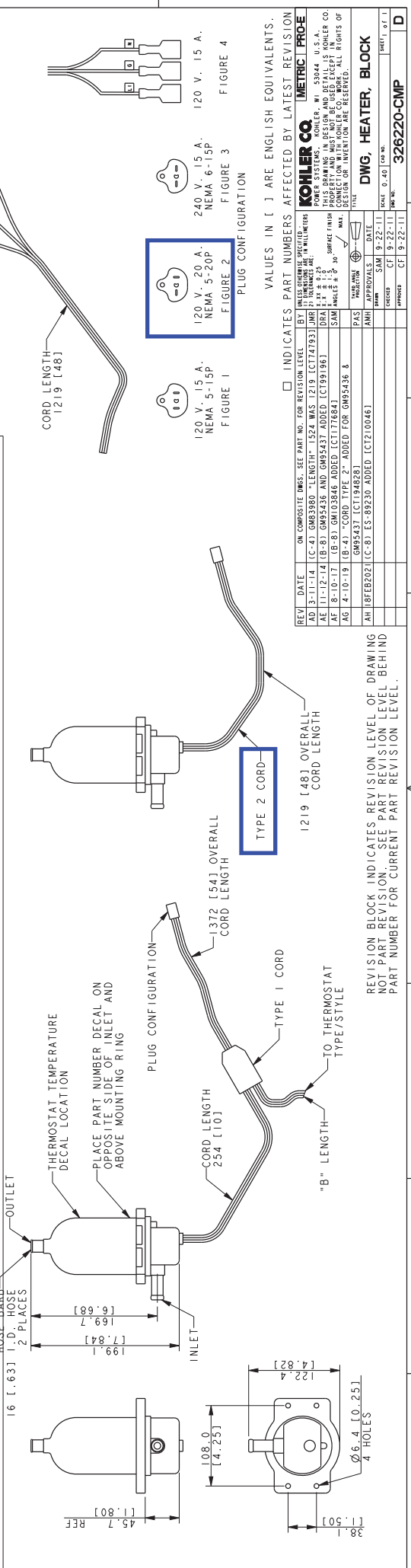

REV	DATE	DESCRIPTION	BY	APP'D
AD	3-11-14	(C-4) GM83980 "LENGTH" 1524 WAS 1219 [C174793]	JME	JME
AE	11-12-14	(B-8) GM95436 AND GM95437 ADDED [C199196]	DRA	JME
AF	8-10-17	(B-8) GM103846 ADDED [C177664]	SAM	JME
AG	4-10-19	(B-4) "CORD TYPE 2" ADDED FOR GM95436 & GM95437 [C1194828]	SAM	JME
AH	18FEB2021	(C-8) ES-89230 ADDED [C1710946]	SAM	JME

ON COMPOSITE DIMS. SEE PART NO. FOR REVISION LEVEL.  
UNLESS OTHERWISE SPECIFIED, DIMENSIONS ARE IN INCHES AND DECIMALS ARE IN THIRDS.  
THIS DRAWING IS THE PROPERTY OF KOHLER CO. IT IS TO BE USED ONLY FOR THE DESIGN OR INVENTION HEREIN. ALL RIGHTS OF DESIGN OR INVENTION ARE RESERVED.

PAS: GM95437 [C1194828]  
AMH: [C1710946]  
DATE: 9-22-11  
SCALE: 0.40  
DWG. HEATER, BLOCK  
326220-CMP  
SHEET 1 OF 1

KIT NUMBER	BASE GRP.	ITEM 1	ITEM 2	ITEM 3	ITEM 4	VOLTAGE	WATTAGE	VIEW	MODEL	REV	
										DATE	BY
GM75555-KA1		352945	25450 00062 (2.33 FT)	25450 00062 (4.67 FT)	-	120	1500	E/F	100/125/150 JD 6081F/HF, TIER I	8-17-10	REN DAMING (20625-2)
GM75555-KA2		352946	X-312-35 (REF)	X-312-49 (REF)	-	240			135/150/180 JD 6068HF, TIER II		
GM75555-KA3		352945	25450 00062 (1.21 FT)	25450 00062 (4.33 FT)	-	120	1500	E/G	50/60/80 JD 4045TF, TIER I		
GM75555-KA4	GM75555-KB	352946	X-312-4 (REF)	X-312-57 (REF)	-	240			50/60/80/100 JD 4045TF/HF, TIER II		
GM75555-KA5		GM75552	25450 00062 (2.33 FT)	25450 00062 (1.83 FT)	X-211-1	120	1800	H	180/200 JD 6068HF, TIER II, III		
GM75555-KA6		GM75553	X-312-35 (REF)	X-312-5 (REF)	GM11694 GM22991	240	2000		125/150 JD 6068HF TIER III		

REV	DATE	BY	REVISION
1	8-17-10	REN DAMING (20625-2)	
2			
3			
4			
5			
6			
7			
8			

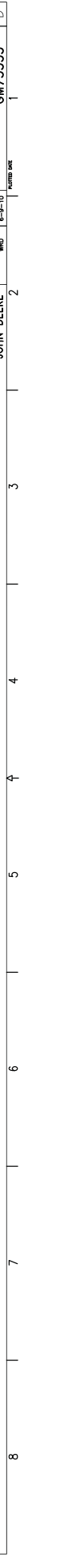
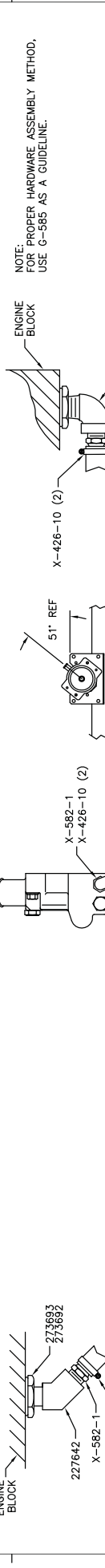
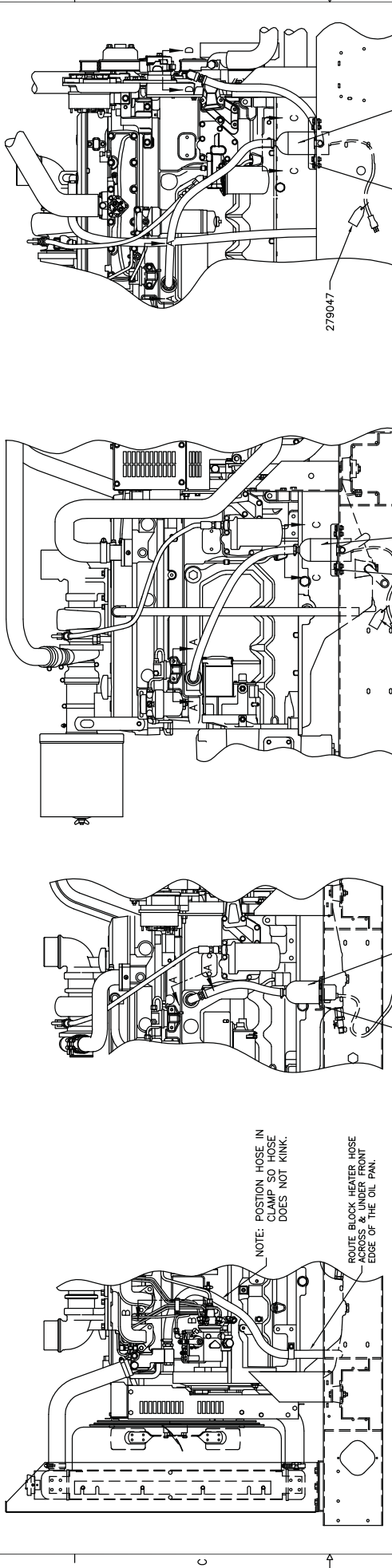

**KOHLER CO.**  
 POWER SYSTEMS, WILKES, W. 20044, U.S.A.  
 ALL RIGHTS RESERVED. COPIES OF THIS DRAWING ARE UNLAWFUL.  
 ALL RIGHTS OF PATENT OR COPYRIGHT ARE RESERVED.

DATE: 8-17-10  
 DRAWN BY: REN DAMING (20625-2)  
 CHECKED BY: MAK  
 APPROVED BY: MAK

ITEM NO: 1500000000  
 PART NO: 1500000000  
 REV: 1-1

ENGINE BLOCK HEATER  
 1500-2000W, 120V/240V  
 4045TF/6068HF  
 JOHN DEERE

GM75555

METRIC CAD FILE

NOTE: FOR PROPER HARDWARE ASSEMBLY METHOD, USE G-585 AS A GUIDELINE.

ENGINE BLOCK

VIEW D-D

VIEW C-C

VIEW B-B

VIEW G

VIEW F

VIEW A-A

VIEW H

PART NO.	PART REV	DESCRIPTION	AMPS	INTERRUPT KA @480 VAC	CONNECTION TYPE		POLES	VOLTS	RATING	TRIP TYPE	SQUARE D PART NO.	CONNECTION CHART		
					LINE	LOAD						CONNECTION TYPE	CONNECTIONS (PER PHASE)	TORQUE
GM85432-1	-	BREAKER, CIRCUIT 400A LGP	400	35	BUS	AL600LS52K3 LUGS	3	600	80%	MICROLOGIC 3.3S LSI	LGP36400U33X	BUS	(1) MLO	50 Nm [442 IN-LB]
GM85432-2	-	BREAKER, CIRCUIT 400A LGP	400	35	BUS	AL600LS52K3 LUGS	3	600	80%	MICROLOGIC 3.3S LSI	LGP36400U33X	BUS	(2) 270-500 KCMIL AL7CU	50 Nm [442 IN-LB]
GM85432-3	-	BREAKER, CIRCUIT 400A LGP	400	35	BUS	AL600LS52K3 LUGS	3	600	100%	MICROLOGIC 6.3A LSTG	LGP36400U44X	BUS	(2) 270-500 KCMIL AL7CU	50 Nm [442 IN-LB]
GM85432-4	-	BREAKER, CIRCUIT 400A LGP	400	35	BUS	AL600LS52K3 LUGS	3	600	100%	MICROLOGIC 3.3S LSI	LGP36400U33X	BUS	(2) 270-500 KCMIL AL7CU	50 Nm [442 IN-LB]
GM85432-5	-	BREAKER, CIRCUIT 400A LGP	400	35	BUS	AL600LS52K3 LUGS	3	600	100%	MICROLOGIC 3.3S LSI	LGP36400U33X	BUS	(2) 270-500 KCMIL AL7CU	50 Nm [442 IN-LB]
GM85432-6	-	BREAKER, CIRCUIT 400A LGP	400	35	BUS	AL600LS52K3 LUGS	3	600	80%	MICROLOGIC 6.3A LSTG	LGP36400U44X	BUS	(2) 270-500 KCMIL AL7CU	50 Nm [442 IN-LB]
GM85432-7	-	BREAKER, CIRCUIT 600A LGP	600	35	BUS	AL600LS52K3 LUGS	3	600	80%	MICROLOGIC 3.3S LSI	LGP36600U33X	BUS	(2) 270-500 KCMIL AL7CU	50 Nm [442 IN-LB]
GM85432-8	-	BREAKER, CIRCUIT 600A LGP	600	35	BUS	AL600LS52K3 LUGS	3	600	80%	MICROLOGIC 3.3S LSI	LGP36600U33X	BUS	(2) 270-500 KCMIL AL7CU	50 Nm [442 IN-LB]
GM85432-9	-	BREAKER, CIRCUIT 600A LGP	600	35	BUS	AL600LS52K3 LUGS	3	600	80%	MICROLOGIC 6.3A LSTG	LGP36600U44X	BUS	(2) 270-500 KCMIL AL7CU	50 Nm [442 IN-LB]

NOTE:  
 (4) M5 X .85 MOUNTING SCREWS, WASHERS AND NUTS INCLUDED.  
 (3) M10 X 25 BUS CONNECTION SCREWS AND SPRING WASHERS INCLUDED.

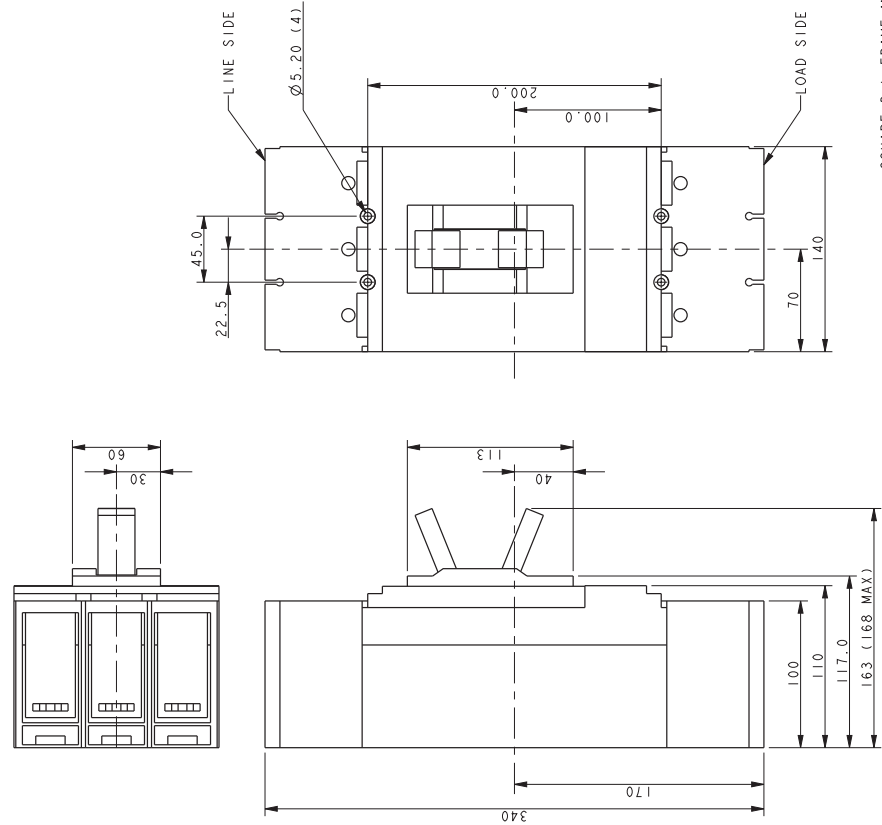

● DENOTES A CRITICAL CHARACTERISTIC THAT MUST BE ADDRESSED IN THE PRODUCTION CONTROL PLAN. TOTAL QUANTITY OF CRITICAL CHARACTERISTICS ON THIS DRAWING = 0

○ DENOTES A MAJOR CHARACTERISTIC THAT MUST BE ADDRESSED IN THE PRODUCTION CONTROL PLAN. TOTAL QUANTITY OF MAJOR CHARACTERISTICS ON THIS DRAWING = 0

KOHLER PART NUMBER TO BE CLEARLY VISIBLE ON CIRCUIT BREAKER AND ON INDIVIDUAL PACKAGING.

□ INDICATES PART NUMBERS AFFECTED BY LATEST DRAWING REVISION

REV	DATE	ON COMPOSITE DWS. SEE PART NO. FOR REVISION LEVEL	BY	UNLESS OTHERWISE SPECIFIED, DIMENSIONS ARE IN MILLIMETERS	SCALE	PROJ.
-	4-3-12	NEW DRAWING [CT142161]	WSD	2.0	1:1	MECHANICAL
-	4-3-12		WSD	2.0	1:1	MECHANICAL
-	4-3-12		WSD	2.0	1:1	MECHANICAL
-	4-3-12		WSD	2.0	1:1	MECHANICAL
-	4-3-12		WSD	2.0	1:1	MECHANICAL
-	4-3-12		WSD	2.0	1:1	MECHANICAL
-	4-3-12		WSD	2.0	1:1	MECHANICAL
-	4-3-12		WSD	2.0	1:1	MECHANICAL
-	4-3-12		WSD	2.0	1:1	MECHANICAL
-	4-3-12		WSD	2.0	1:1	MECHANICAL

APPROVALS	DATE	TITLE	SCALE	PROJ.
WSD	4-3-12	DESIGN	1:1	MECHANICAL
WSD	4-3-12	DESIGN	1:1	MECHANICAL
WSD	4-3-12	DESIGN	1:1	MECHANICAL
WSD	4-3-12	DESIGN	1:1	MECHANICAL
WSD	4-3-12	DESIGN	1:1	MECHANICAL
WSD	4-3-12	DESIGN	1:1	MECHANICAL
WSD	4-3-12	DESIGN	1:1	MECHANICAL
WSD	4-3-12	DESIGN	1:1	MECHANICAL
WSD	4-3-12	DESIGN	1:1	MECHANICAL
WSD	4-3-12	DESIGN	1:1	MECHANICAL

SQUARE D L-FRAME MICROLOGIC BREAKERS

GM85432-CMP

DWG. CIRCUIT BREAKER

SCALE 1:1

SHEET 1 OF 1

BREAKER FRAME	AL/CU MECHANICAL LOAD LUGS PER PHASE		A WIRE BENDING SPACE	
	AMPS	WIRE RANGE	WIRE RANGE	TRIP TYPE
H	15-150	(1) #14 TO 3/0	427 [16.8]	ALL
	175	(1) 1/0 TO 4/0	413 [16.3]	ALL
	200-250	(1) 3/0 TO 350 KCMIL	369 [14.5]	ALL
LA	300-400	(1) #1 TO 600-KCMIL OR (2) #1 TO 250-KCMIL	369 [14.5]	ALL
	400-600	(2) 2/0 TO 500 KCMIL AL/CU	362 [14.2]	NO L5IG
M	800	(3) 3/0 TO 500 KCMIL	341 [13.4]	NO L5IG
P	250-800			NO L5IG
<b>MECHANICAL LOAD LUGS INCLUDED WITH H, J &amp; LG L5IG NEUTRALS</b>				
H	60-150	(1) #14 TO 3/0 AWG AL/CU		
J	250	(1) 3/0 TO 350 KCMIL AL/CU		
LG	400-600	(2) 4/0 TO 500 KCMIL AL/CU		

STANDARD BREAKER COMBINATIONS			
BREAKER 1	BREAKER 2	BREAKER 3	TRIP TYPE
H OR J	-	-	ALL
LA	-	-	ALL
LG	-	-	ALL
M	-	-	ALL
P	-	-	ALL
H OR J	H OR J	H OR J	NO L5IG
LA	H, J OR LA	-	NO L5IG
LG	H, J, LA OR LG	-	NO L5IG
M OR P	H, J, LA OR LG	-	NO L5IG

- NOTES:**
- SEE UNIT DIMENSION PRINT (ADV-XXXX) FOR ADDITIONAL DIMENSIONS, JUNCTION BOX AND STUB-UP LOCATION.
  - ADD SKID DEPTH TO WIRE BENDING HEIGHTS ON THIS PRINT TO ARRIVE AT FULL WIRE-BENDING SPACE.
  - CONSULT FACTORY FOR BREAKER COMBINATIONS NOT SHOWN ON THIS PRINT.
  - MECHANICAL LUGS ARE AVAILABLE FOR NON-L5IG NEUTRAL. SEE ADV-7376. H, J & LG L5IG NEUTRALS INCLUDE LUGS (SEE CHART).
  - NEUTRALS ARE BONDED TO GROUND AS STANDARD. CONSULT LOCAL CODES OR SYSTEM REQUIREMENTS.
  - CIRCUIT BREAKER FRAMES REFER TO STANDARD SQUARE-D PRODUCT.
  - STANDARD NEUTRALS PROVIDED ARE SIZED FOR MAXIMUM UNIT AMPS. L5IG NEUTRALS ARE MATCHED TO THEIR CIRCUIT BREAKER AMPS.
  - DIMENSIONS ARE MM, DIMENSIONS IN [ ] ARE INCHES.

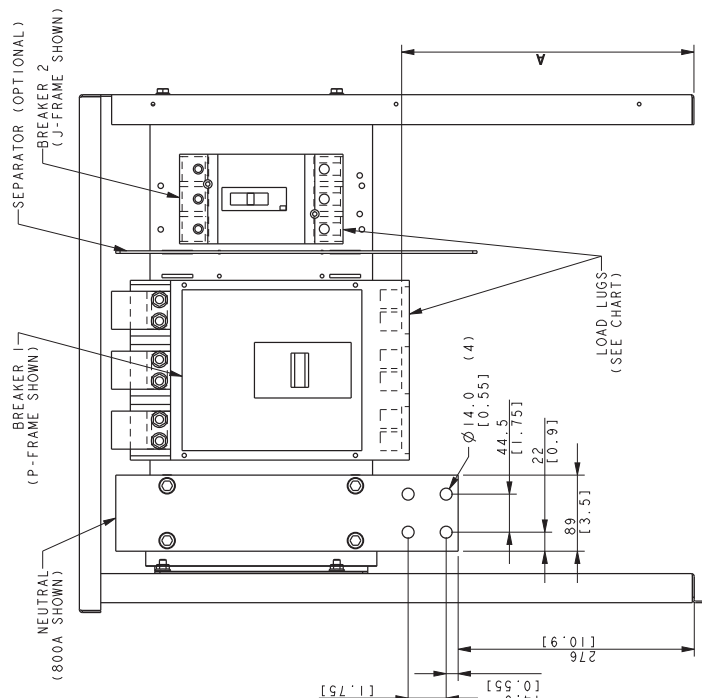

RIGHT SIDE SHOWN WITH COVERS REMOVED

FRAME	UL INTERRUPT KA RATINGS
BREAKER • 240V • 480V • 600V	
HD	25 18 14
HG	65 35 18
HJ	100 65 25
JD	25 18 14
JG	65 35 18
JJ	100 65 25
LA	42 30 22
LG	65 35 18
MG	65 35 18
PG	65 35 18
PJ	100 65 25
PL	125 100 25

FRAME	ELECTRONIC TRIP UNITS
H	LSI MICROLOGIC 3.2S
	LSI MICROLOGIC 3.2S
	LSI MICROLOGIC 6.2A
J	LSI MICROLOGIC 3.2S
	LSI MICROLOGIC 3.2S
	LSI MICROLOGIC 6.2A
LG	LSI MICROLOGIC 3.3S
	LSI MICROLOGIC 3.3S
	LSI MICROLOGIC 6.3A
M	LI ET 1.0
	LI ET 1.01
P	LSI MICROLOGIC 3.0
	LSI MICROLOGIC 5.0
	LSI MICROLOGIC 6.0A

ELECTRICALLY OPERATED BREAKERS FOR DEC6000 DPS OR APM603 PARALLELING ONLY NO 2ND BREAKERS ARE ALLOWED	
RATING AMPS	TRIP TYPE
250	PJ OR PL
400	ELECTRONIC LI OR LSI
100%	
600	
800	

VIEW FROM ENGINE END (HALF VIEW SHOWN)

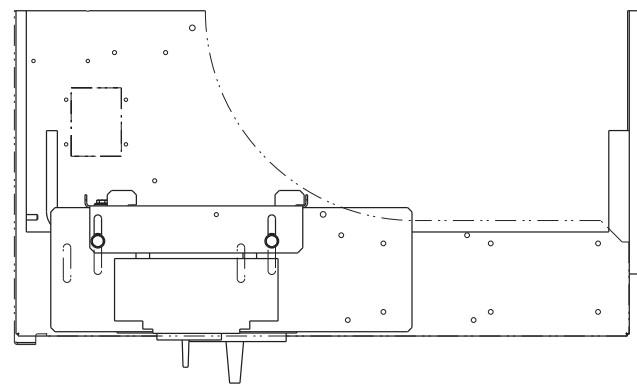

REV.	DATE	BY	DESCRIPTION
5-16-07		MSD	NEW DRAWING 1796773
4-22-08		MSD	(D-8) 15-150 WAS 40-150 (84767)
10-19-12		MSD	NEUTRAL LUG CHART ADDED (C176372)
11-2-16		MSD	(D-8) REMOVED SEPARATE LINES FOR H & J 100% (C1114236)
3-26-19		MSD	EA-6 EOB TABLE ADDED (C1194577)
3-24-19		MSD	EA-6 100% & 1200% REMOVED (C1196063)
18-7-21		MSD	(D-8) M 800A WAS 700 & 800.LI WAS (C1212832)

DO NOT SCALE. REFERENCE THE MODEL FOR ALL UNSPECIFIED DIMENSIONS

**KOHLER**  
 THIS DRAWING IS THE PROPERTY OF KOHLER. IT IS TO BE USED ONLY FOR THE DESIGN OR INVENTION OF DESIGN OR INVENTION ARE RESERVED.

SCALE: 0.35 (4X)  
 DATE: 5-16-07  
 DRAWN BY: MSD  
 CHECKED BY: MSD  
 APPROVED BY: MSD

UNIT: INCHES  
 TITLE: ADV-7371

4 3 2 1

PART NO.	DESCRIPTION
222655	REPLACEMENT GLASS ROD

REV	DATE	REVISION	BY
A	9-1-93	(B-2) SWITCHING NORMALLY CLOSED WAS SWITCHING NORMALLY OPEN (CAN BE CONVERTED TO N.C.)	SAV
B	3-7-94	GENERIC TITLEBLOCK ADDED	PWH

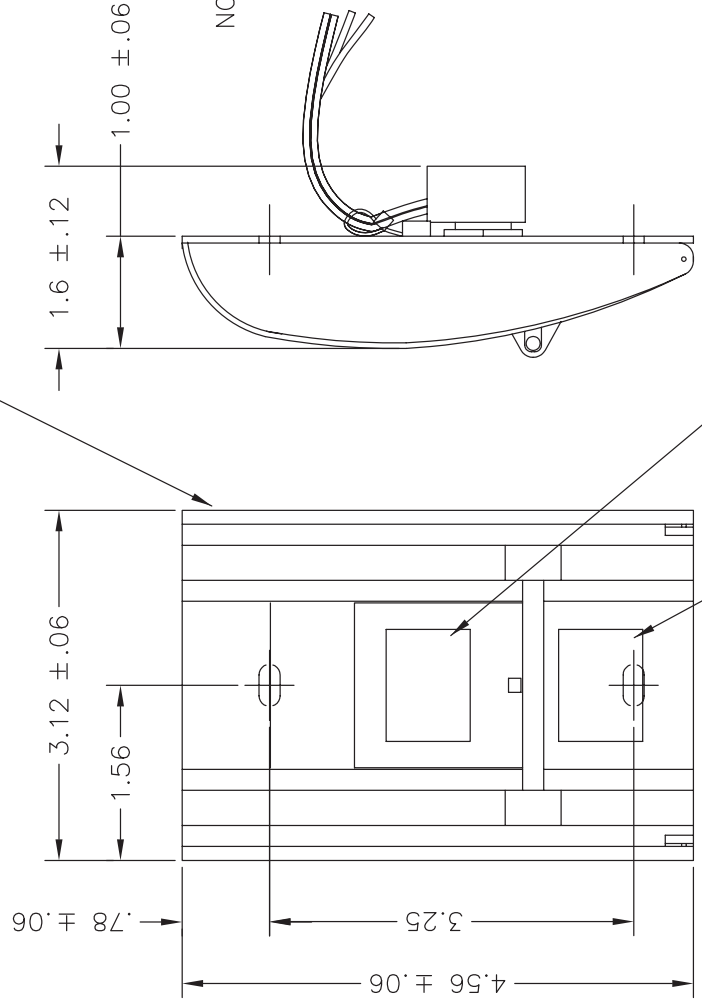

NOTE:  
BREAKGLASS TYPE FOR CLOSED CIRCUIT OPERATION UP TO 48 VOLTS.

MOUNTING INSTRUCTIONS:  
FOR WALL MOUNTING USE #6 ROUND HEAD WOOD SCREWS.  
FOR MOUNTING ON GEM BOX OR SINGLE GANG PLASTER COVER, USE MACHINE SCREWS IN ENVELOPE.

SWITCHING NORMALLY CLOSED.

EXTRA PIECE OF GLASS TO BE SUPPLIED WITH SWITCH.

MATERIAL: METAL (STEEL)

UNLESS OTHERWISE SPECIFIED - 1) DIMENSIONS ARE IN INCHES 2) TOLERANCES ARE: .XXX ± .010 .XX ± .030 X ± .060 FRACTIONS ± MAX.		APPROVALS		DATE	
DRAWN	KDW	CHECKED	EB	APPROVED	RLD
8-12-92		9-9-92		9-9-92	
SCALE FULL		PLOTTED		SHEET 1-1	
TITLE		DRAWING NO.		DWG. NO.	
EMERGENCY STOP		A222654.dwg		A-222654	
POWER SYSTEMS, KOHLER, WI 53044 U.S.A.		THIS DRAWING IS THE PROPERTY OF KOHLER CO. AND MUST NOT BE USED EXCEPT IN CONNECTION WITH KOHLER CO. WORK. ALL RIGHTS OF DESIGN OR INVENTION ARE RESERVED.		B	

D C B A

4 3 2 1

**KOHLER®**

# Warranty

# Stationary Standby and Prime Power Industrial Generator Set One-Year or Two Thousand (2000)-Hour Limited Warranty

Your product has been manufactured and inspected with care by experienced craftsmen. If you are the original end user, Discovery Energy, LLC warrants, for the period indicated below, each product to be free from defects in materials and workmanship. In the event of a defect in materials or workmanship, Discovery Energy, LLC will repair, replace, or make appropriate adjustment at Discovery Energy, LLC's option if the product, upon Discovery Energy, LLC's inspection, is found to be properly installed, maintained, and operated in accordance with Discovery Energy, LLC's instruction manuals. A distributor, dealer, or authorized service representative must perform startup.

Product	Warranty Coverage
Stationary Standby Generator Set & Accessories	One (1) year from registered startup or two thousand (2000) hours (whichever occurs first). In any event, the warranty period will expire not later than thirty (30) months from the date of shipment from Discovery Energy, LLC's factory.
Stationary Prime Power Generator Set & Accessories	One (1) year from registered startup or two thousand (2000) hours (whichever occurs first). In any event, the warranty period will expire not later than thirty (30) months from the date of shipment from Discovery Energy, LLC's factory.

**Standby rated generators may only be used in Stationary "emergency" applications, where the generator set is the secondary power source, and a dependable utility is the primary power source. Use of a standby rated generator in a stationary "non-emergency" application, or any non-stationary application, is not allowed and voids all factory warranties.**

The following will **not** be covered by the warranty:

1. Normal wear, routine tuneups, tuneup parts, adjustments, and periodic service.
2. Damage, including but not limited to damage caused by accidents, improper installation or handling, faulty repairs not performed by an authorized service representative, improper storage, or acts of God.
3. Damage caused by operation at speeds, or with fuel, loads, conditions, modifications or installation contrary to published specifications.
4. Damage caused by negligent maintenance such as:
  - a. Failure to provide the specified type and sufficient quantity of lubricating oil.
  - b. Failure to keep the air intake and cooling fin areas clean.
  - c. Failure to service the air cleaner.
  - d. Failure to provide sufficient coolant and/or cooling air.
  - e. Failure to perform scheduled maintenance as prescribed in supplied manuals.
  - f. Failure to regularly exercise the generator set under load (stationary applications only).
5. Original installation charges and startup costs.
6. Starting batteries and the following related expenses:
  - a. Labor charges related to battery service.
  - b. Travel expenses related to battery service.
7. Engine coolant heaters, heater controls, and circulating pumps after the first year of the warranty period.
8. Additional expenses for repairs performed after normal business hours, i.e. overtime or holiday labor rates.
9. Rental of equipment during the performance of warranty repairs.
10. Removal and replacement of non-Energy-supplied options and equipment.
11. Non-Energy replacement parts. Replacement of a failed part with a non-Energy part voids the warranty on that part.
12. Radiators replaced rather than repaired.
13. Fuel injection pumps not repaired by an authorized service representative.
14. Non-authorized repair shop labor without prior approval from Discovery Energy, LLC Warranty Department.
15. Engine fluids such as fuel, oil, or coolant/antifreeze.
16. Shop supplies such as adhesives, cleaning solvents, and rags.
17. Expenses incurred investigating performance complaints unless the problem is caused by defective materials or workmanship.
18. Maintenance items such as fuses, lamps, filters, spark plugs, loose or leaking clamps, and adjustments.
19. Travel time and mileage exceeding 300 miles round trip.

To obtain warranty service, call 1-800-544-2444 for your nearest authorized service representative or write Discovery Energy, LLC, Service Department, MS072, Kohler, WI 53044 USA.

**DISCOVERY ENERGY, LLC SHALL NOT BE LIABLE FOR SPECIAL, INCIDENTAL, AND/OR CONSEQUENTIAL DAMAGES OF ANY KIND including, but not limited to, incidental and/or consequential labor costs, installation charges, telephone charges, or transportation charges in connection with the replacement or repair of defective parts.**

This is our exclusive written warranty. We make no other express warranty nor is anyone authorized to make any on our behalf.

**ANY IMPLIED OR STATUTORY WARRANTY, INCLUDING ANY WARRANTY OF MERCHANTABILITY OR FITNESS FOR A PARTICULAR PURPOSE, IS EXPRESSLY LIMITED TO THE DURATION OF THIS WARRANTY. Some states do not allow limitations on how long an implied warranty lasts, or the exclusion or limitation of incidental and/or consequential damages, so the above limitation or exclusion may not apply to you.**

This warranty gives you specific legal rights, and you may also have other rights which vary from state to state.

**KOHLER**<sup>®</sup>

DISCOVERY ENERGY, LLC  
200 Twin Oaks Road, Kohler, WI 53044 USA  
For the nearest sales and service outlet in the  
US and Canada, phone 1-800-544-2444  
KOHLEREnergy.com TP-5374 7/24g

**KOHLER®**

# Certification

# Certificate of Registration

QUALITY MANAGEMENT SYSTEM - ISO 9001:2015

This is to certify that:

Kohler Power Systems  
N7650 Lakeshore Road  
Sheboygan  
Wisconsin  
53083  
USA

Holds Certificate No:

**FM 727336**

and operates a Quality Management System which complies with the requirements of ISO 9001:2015 for the following scope:

Design, manufacture, and distributor support for electrical generators, alternators, fuel tanks, automatic transfer switches and switchgear.

For and on behalf of BSI:

  
\_\_\_\_\_  
Carlos Pitanga, Chief Operating Officer Assurance – Americas

Original Registration Date: 1995-02-28

Latest Revision Date: 2021-10-29

Effective Date: 2021-11-07

Expiry Date: 2024-11-06

Page: 1 of 2



...making excellence a habit.™

Certificate No: **FM 727336**

Location	Registered Activities
Kohler Power Systems - GK 900 Highland Drive Bldg 604 Kohler Wisconsin 53004 USA	Manufacture of leads and harness, automatic transfer switches and switchgear. Distribution of generator sets.
Kohler Power Systems N7650 Lakeshore Road Sheboygan Wisconsin 53083 USA	Design, manufacture, and distributor support for electrical generators, automatic transfer switches and switchgear.
Kohler Power Systems 300 N Dekora Woods Blvd Saukville Wisconsin 53080 USA	Manufacture of fuel tanks, skids, fabricated components and generators.
Kohler Power Systems Muth Warehouse 2821 Muth Court Sheboygan Wisconsin 53083 USA	The distribution of generator sets.
Kohler Power Systems KWIP Warehouse 4327 County EE Sheboygan Wisconsin 53081 USA	Receiving, sequencing and warehousing of generator components.

Original Registration Date: 1995-02-28

Latest Revision Date: 2021-10-29

Effective Date: 2021-11-07

Expiry Date: 2024-11-06

Page: 2 of 2

This certificate remains the property of BSI and shall be returned immediately upon request.

An electronic certificate can be authenticated [online](https://www.bsigroup.com/ClientDirectory). Printed copies can be validated at [www.bsigroup.com/ClientDirectory](https://www.bsigroup.com/ClientDirectory)  
To be read in conjunction with the scope above or the attached appendix.

Information and Contact: BSI, Kitemark Court, Davy Avenue, Knowlhill, Milton Keynes MK5 8PR. Tel: + 44 345 080 9000  
BSI Assurance UK Limited, registered in England under number 7805321 at 389 Chiswick High Road, London W4 4AL, UK.  
A Member of the BSI Group of Companies.

G15-152 10/21

# PROTOTYPE TEST REPORT



Models Covered: **180REOZJG**  
Model Tested: **180REOZJF**  
Cooling System Tested: **50C**

Alternator Tested: **4S12X**  
Engine Tested: **6068HFG82**  
Voltage Tested: **480V**

## GENSET

**Maximum power test** to assure that the prime mover and alternator have sufficient capacity to operate within specifications.

**Meets Rated Load**

**Steady-state load test** to ensure voltage stability meets or exceeds ISO8528-5 requirements and to verify compliance with steady state speed control specifications.

**± 0.25 %** Frequency Band

**± 0.50 %** Voltage Deviation

**Transient load tests** per NEMA MG1-32.18, and ISO 8528 to verify specifications of transient voltage regulation, voltage dip, voltage overshoot, recovery voltage, and recovery time. Values shown for model tested above. Please contact factory for additional details.

### Full Load Acceptance

**46.6 %** Voltage Dip

**5.60** Seconds of Recovery Time

**28.5 %** Frequency Dip

**2.90** Seconds of Recovery Time

### Full Load Rejection

**11.8 %** Voltage Overshoot

**4.40** Seconds of Recovery Time

**6.90 %** Frequency Overshoot

**0.40** Seconds of Recovery Time

**G3** ISO8528-5 Class (G1, G2, G3)

**NFPA 110 one step testing** to determine the amount of time required for the generator set to reach 90% voltage and frequency to allow the ATS to transfer.

**Complies with NFPA 110 Type 10**

**Vibrational analysis** to verify that generator vibrations are within acceptable limits per ISO 8528-9.

**Complies**

**Torsional analysis data** to verify torsional effects are not detrimental and that the generator set will provide dependable service as specified.

**Complies**

**Generator set cooling and air flow tests** to verify maximum operating ambient temperature. (Cooling system test results are available on TIB-118)

**Acoustical noise intensity and sound attenuation effects tests** (Acoustical noise results are available on TIB-114 &115)

**Exhaust Back Pressure test** completed to demonstrate within engine limitation (Exhaust back pressure test results are available on TIB-119)

# PROTOTYPE TEST REPORT



Models Covered: **180REOZJG**  
Model Tested: **180REOZJF**  
Cooling System Tested: **50C**

Alternator Tested: **4S12X**  
Engine Tested: **6068HFG82**  
Voltage Tested: **480V**

## ALTERNATOR

**Alternator temperature rise test** per NEMA MG1-32.6. Standby and prime ratings of the alternator are established during this test.

**Alternator overload test** per NEMA MG1-32.8. Motor starting tests per NEMA MG1-32.18.5 to evaluate capabilities of generator, exciter, and regulator system.

**Three-phase symmetrical short-circuit test** per NEMA MG1-32.13 to demonstrate short circuit performance, mechanical integrity, ability to sustain short-circuit current.

**Harmonic analysis, voltage waveform deviation** per NEMA MG1-32.10 to confirm that the generator set is producing clean voltage within acceptable limits.

(Alternator detailed test results are available on TIB-102)

# Kohler Standby/Prime Generator Set Test Program

Testing is an integral part of quality assurance. In keeping with our uncompromising commitment to quality, safety, and reliability, every Kohler Standby/Prime power generator set undergoes an extensive series of prototype and production testing.

## Prototype Testing

Prototype testing includes the potentially destructive tests necessary to verify design, proper function of protective devices and safety features, and reliability expectations. Kohler's prototype testing includes the following:

- Alternator temperature rise test per NEMA MG1-32.6. Standby and prime ratings of the alternator are established during this test.
- Maximum power test to assure that the prime mover and alternator have sufficient capacity to operate within specifications.
- Alternator overload test per NEMA MG1-32.8.
- Steady-state load test to ensure voltage regulation meets or exceeds ANSI C84.1, NEMA MG1-32.17 requirements and to verify compliance with steady-state speed control specifications.
- Transient test to verify speed controls meets or exceeds specifications.
- Transient load tests per NEMA MG1-32.18, and ISO 8528 to verify specifications of transient voltage regulation, voltage dip, voltage overshoot, recovery voltage, and recovery time.
- Motor starting tests per NEMA MG1-32.18.5 to evaluate capabilities of generator, exciter, and regulator system.
- Three-phase symmetrical short-circuit test per NEMA MG1-32.13 to demonstrate short circuit performance, mechanical integrity, ability to sustain short-circuit current.
- Harmonic analysis, voltage waveform deviation per NEMA MG1-32.10 to confirm that the generator set is producing clean voltage within acceptable limits.

Torsional analysis data, to verify torsional effects are not detrimental and that the generator set will provide dependable service as specified, is available upon request.

Kohler offers other testing at the customer's request at an additional charge. These optional tests include power factor testing, customized load testing for specific application, witness testing, and a broad range of MIL-STD-705c testing. A certified test report is also available at an additional charge.

- Generator set cooling and air flow tests to verify maximum operating ambient temperature.
- Reliability tests to demonstrate product durability, followed by root cause analysis of discovered failures and defects. Corrective action is taken to improve the design, workmanship, or components.
- Acoustical noise intensity and sound attenuation effects tests.

## Production Testing

In production, Kohler Standby/Prime generator sets are built to the stringent standards established by the prototype program. Every Kohler generator set is fully tested prior to leaving the factory. Production testing includes the following:

- Stator and exciter winding high-potential test on all generators. Surge transient tests on stators for generators 180 kW or larger. Continuity and balance tests on all rotors.
- One-step, full-load pickup tests to verify that the performance of each generator set, regulator, and governor meets published specifications.
- Regulation and stability of voltage and frequency are tested and verified at no load, 1/4 load, 1/2 load, 3/4 load, and full-rated load.
- Voltage, amperage, frequency and power output ratings verified by full-load test.
- The proper operation of controller logic circuitry, prealarm warnings, and shutdown functions is tested and verified.
- Any defect or variation from specification discovered during testing is corrected and retested prior to approval for shipment to the customer.

**KOHLER**®

KOHLER CO. Kohler, Wisconsin 53044  
Phone 920-565-3381, Fax 920-459-1646  
For the nearest sales/service outlet in the  
US and Canada, phone 1-800-544-2444  
KohlerPowerSystems.com

**KOHLER®**

# PreStartup Checklist

## Generator Set/Transfer Switch Installation Checklist

This document has generic content and some items may not apply to some applications. Check only the items that apply to the specific application. Read and understand all of the safety precautions found in the Operation and Installation Manuals. Make the following installation checks before performing the Startup Checklist.

**Note:** Use this form as a general guide, along with any applicable codes or standards. Comply with all applicable codes and standards. Improper installation voids the warranty.

		Does Not Apply	
<b>Equipment Room or Weather Housing</b>			
<div style="display: flex; justify-content: space-between;"> <span>Does Not Apply</span> <span>Yes</span> </div>	<div style="display: flex; justify-content: space-between;"> <span>Yes</span> <span>Not Apply</span> </div>		
<input type="checkbox"/> <input type="checkbox"/>			25. Is there an exhaust line condensate trap with a drain installed?
<input type="checkbox"/> <input type="checkbox"/>			26. Is the specified silencer installed and are the hanger and mounting hardware tightened?
<input type="checkbox"/> <input type="checkbox"/>			27. Is a heat-isolating thimble(s) installed at points where exhaust lines pass through combustible wall(s) or partition(s)?
<input type="checkbox"/> <input type="checkbox"/>			28. Is the exhaust line free of excessive bends and restrictions? Is the backpressure within specifications?
<input type="checkbox"/> <input type="checkbox"/>			29. Is the exhaust line installed with a downward pitch toward the outside of the building?
<input type="checkbox"/> <input type="checkbox"/>			30. Is the exhaust line protected from entry by rain, snow, and animals?
<input type="checkbox"/> <input type="checkbox"/>			31. Does the exhaust system outlet location prevent entry of exhaust gases into buildings or structures?
<input type="checkbox"/> <input type="checkbox"/>			32. Are individuals protected from exposure to high temperature exhaust parts and are hot parts safety decals present?
<b>Engine and Mounting</b>			
<input type="checkbox"/> <input type="checkbox"/>			7. Is the mounting surface(s) properly constructed and leveled?
<input type="checkbox"/> <input type="checkbox"/>			8. Is the mounting surface made from non-combustible material?
<input type="checkbox"/> <input type="checkbox"/>			9. Was the generator-to-engine alignment performed after attaching the skid to the mounting base? Generator sets with two-bearing generators require alignment.
<b>Lubrication</b>			
<input type="checkbox"/> <input type="checkbox"/>			10. Is the engine crankcase filled with the specified oil?
<b>Cooling and Ventilation</b>			
<input type="checkbox"/> <input type="checkbox"/>			11. Is the cooling system filled with the manufacturer's specified coolant/antifreeze and purged of air?
<input type="checkbox"/> <input type="checkbox"/>			12. Is there adequate inlet and outlet air flow (electric louvers adjusted and ventilation fan motor(s) connected to the corresponding voltage)?
<input type="checkbox"/> <input type="checkbox"/>			13. Is the radiator duct properly sized and connected to the air vent or louver?
<input type="checkbox"/> <input type="checkbox"/>			14. Are flexible sections installed in the cooling water lines?
<b>Fuel</b>			
<input type="checkbox"/> <input type="checkbox"/>			15. Is there an adequate/dedicated fuel supply?
<input type="checkbox"/> <input type="checkbox"/>			16. Are the fuel filters installed?
<input type="checkbox"/> <input type="checkbox"/>			17. Are the fuel tanks and piping installed in accordance with applicable codes and standards?
<input type="checkbox"/> <input type="checkbox"/>			18. Is there adequate fuel transfer tank pump lift capacity and is the pump motor connected to the corresponding voltage?
<input type="checkbox"/> <input type="checkbox"/>			19. Is the fuel transfer tank pump connected to the emergency power source?
<input type="checkbox"/> <input type="checkbox"/>			20. Are flexible fuel lines installed between the engine fuel inlet and fuel piping?
<input type="checkbox"/> <input type="checkbox"/>			21. Is the specified gas pressure available at the fuel regulator inlet?
<input type="checkbox"/> <input type="checkbox"/>			22. Does the gas solenoid valve function?
<input type="checkbox"/> <input type="checkbox"/>			23. Are the manually operated fuel and cooling water valves installed allowing manual operation or bypass of the solenoid valves?
<b>Exhaust</b>			
<input type="checkbox"/> <input type="checkbox"/>			24. Is the exhaust line sized per guidelines and does it have flexible connector(s)? Is the flexible connector(s) straight?
<b>AC Electrical System</b>			
<input type="checkbox"/> <input type="checkbox"/>			33. Does the nameplate voltage/frequency of the generator set and transfer switch match normal/utility source ratings?
<input type="checkbox"/> <input type="checkbox"/>			34. Do the generator set load conductors have adequate ampacity and are they correctly connected to the circuit breakers and/or the emergency side of the transfer switch?
<input type="checkbox"/> <input type="checkbox"/>			35. Are the load conductors, engine starting cables, battery charger cables, and remote annunciator leads installed in separate conduits?
<input type="checkbox"/> <input type="checkbox"/>			36. Is the battery charger AC circuit connected to the corresponding voltage?
<b>Transfer Switch, Remote Control System, Accessories</b>			
<input type="checkbox"/> <input type="checkbox"/>			37. Is the transfer switch mechanism free of binding? <b>Note:</b> Disconnect all AC sources and operate the transfer switch manually.
<input type="checkbox"/> <input type="checkbox"/>			38. Are the transfer switch AC conductors correctly connected? Verify lead designations using the appropriate wiring diagrams.
<input type="checkbox"/> <input type="checkbox"/>			39. Is all other wiring connected, as required?
<b>Batteries and DC Electrical System</b>			
<input type="checkbox"/> <input type="checkbox"/>			40. Does the battery(ies) have the specified CCA rating and voltage?
<input type="checkbox"/> <input type="checkbox"/>			41. Is the battery(ies) filled with electrolyte and connected to the battery charger?
<input type="checkbox"/> <input type="checkbox"/>			42. Are the engine starting cables connected to the battery(ies)?
<input type="checkbox"/> <input type="checkbox"/>			43. Do the engine starting cables have adequate length and gauge?
<input type="checkbox"/> <input type="checkbox"/>			44. Is the battery(ies) installed with adequate air ventilation?
<input type="checkbox"/> <input type="checkbox"/>			45. Are the ends of all spark plug wires properly seated onto the coil/distributor and the spark plug?
<b>Special Requirements</b>			
<input type="checkbox"/> <input type="checkbox"/>			46. Is the earthquake protection adequate for the equipment and support systems?
<input type="checkbox"/> <input type="checkbox"/>			47. Is the equipment protected from lightning damage?

## Generator Set/Transfer Switch Startup Checklist

This document has generic content and some items may not apply to some applications. Check only the items that apply to the specific application. Read and understand all of the safety precautions found in the Operation and Installation Manuals. Complete the Installation Checklist before performing the initial startup checks. Refer to Service Bulletin 616 for Warranty Startup Procedure Requirements regarding generator set models with ECM-controlled engines.

- | Does<br>Not<br>Yes Apply                          |     | Does<br>Not<br>Yes Apply                          |   |
|---|-----|---|---|
| <input type="checkbox"/> <input type="checkbox"/> | 1.  | <input type="checkbox"/> <input type="checkbox"/> | 29. Close the normal source circuit breaker or replace fuses to the transfer switch.  |
| <input type="checkbox"/> <input type="checkbox"/> | 2.  | <input type="checkbox"/> <input type="checkbox"/> | 30. Check the normal source voltage, frequency, and phase sequence on three-phase models. The normal source must match the load.  |
| <input type="checkbox"/> <input type="checkbox"/> | 3.  | <input type="checkbox"/> <input type="checkbox"/> | 31. Open the normal source circuit breaker or remove fuses to the transfer switch.  |
| <input type="checkbox"/> <input type="checkbox"/> | 4.  | <input type="checkbox"/> <input type="checkbox"/> | 32. Manually transfer the load to the normal source.  |
| <input type="checkbox"/> <input type="checkbox"/> | 5.  | <input type="checkbox"/> <input type="checkbox"/> | 33. Close the generator set main line circuit breakers, close the safeguard breaker, and/or replace the fuses connected to the transfer switch.   |
| <input type="checkbox"/> <input type="checkbox"/> | 6.  | <input type="checkbox"/> <input type="checkbox"/> | 34. Place the generator set master switch in the RUN position.  |
| <input type="checkbox"/> <input type="checkbox"/> | 7.  | <input type="checkbox"/> <input type="checkbox"/> | 35. Check the generator set voltage, frequency, and phase sequence on three-phase models. The generator set must match normal source and load.  |
| <input type="checkbox"/> <input type="checkbox"/> | 8.  | <input type="checkbox"/> <input type="checkbox"/> | 36. Place the generator set master switch in the OFF/RESET position.  |
| <input type="checkbox"/> <input type="checkbox"/> | 9.  | <input type="checkbox"/> <input type="checkbox"/> | 37. Open the generator set main line circuit breakers, open the safeguard breaker, and/or remove the fuses connected to the transfer switch.  |
| <input type="checkbox"/> <input type="checkbox"/> | 10. | <input type="checkbox"/> <input type="checkbox"/> | 38. Reconnect the power switching device and logic controller wire harness at the inline disconnect plug at the transfer switch.  |
| <input type="checkbox"/> <input type="checkbox"/> | 11. | <input type="checkbox"/> <input type="checkbox"/> | 39. Close the normal source circuit breaker or replace fuses to the transfer switch. Place the generator set master switch to the AUTO position.  |
| <input type="checkbox"/> <input type="checkbox"/> | 12. | <input type="checkbox"/> <input type="checkbox"/> | 40. Close the generator set main line circuit breakers, close the safeguard breaker, and/or replace the fuses connected to the transfer switch.   |
| <input type="checkbox"/> <input type="checkbox"/> | 13. | <input type="checkbox"/> <input type="checkbox"/> | 41. Place the transfer switch in the TEST position (load test or open normal source circuit breaker). <b>NOTE:</b> Obtain permission from the building authority before proceeding. This procedure tests transfer switch operation and connects building load to generator set power. |
| <input type="checkbox"/> <input type="checkbox"/> | 14. | <input type="checkbox"/> <input type="checkbox"/> | 42. Readjust frequency to 50 or 60 Hz with total building loads.*   |
| <input type="checkbox"/> <input type="checkbox"/> | 15. | <input type="checkbox"/> <input type="checkbox"/> | 43. Verify that the current phase is balanced for three phase systems.  |
| <input type="checkbox"/> <input type="checkbox"/> | 16. | <input type="checkbox"/> <input type="checkbox"/> | 44. Release the transfer switch test switch or close the normal circuit breaker. The transfer switch should retransfer to the normal source after appropriate time delay(s).  |
| <input type="checkbox"/> <input type="checkbox"/> | 17. | <input type="checkbox"/> <input type="checkbox"/> | 45. Allow the generator set to run and shut down automatically after the appropriate cool down time delay(s).   |
| <input type="checkbox"/> <input type="checkbox"/> | 18. | <input type="checkbox"/> <input type="checkbox"/> | 46. Set the plant exerciser to the customer's required exercise period, if equipped.  |
| <input type="checkbox"/> <input type="checkbox"/> | 19. | <input type="checkbox"/> <input type="checkbox"/> | 47. Verify that all options on the transfer switch are adjusted and functional for the customer's requirements.   |
| <input type="checkbox"/> <input type="checkbox"/> | 20. | <input type="checkbox"/> <input type="checkbox"/> | 48. If possible, run the building loads on the generator set for several hours or perform the load bank test if required.   |
| <input type="checkbox"/> <input type="checkbox"/> | 21. | <input type="checkbox"/> <input type="checkbox"/> | 49. Verify that all the wire connections from the generator set to the transfer switch and optional accessories are tight and secure.   |
| <input type="checkbox"/> <input type="checkbox"/> | 22. | <input type="checkbox"/> <input type="checkbox"/> | 50. Verify that the customer has the appropriate engine/generator set and transfer switch literature. Instruct the customer in the operation and maintenance of the power system.   |
| <input type="checkbox"/> <input type="checkbox"/> | 23. | <input type="checkbox"/> <input type="checkbox"/> | 51. Fill out the startup notification at this time and send the white copy to the Generator Warranty Dept. Include the warranty form if applicable.   |
| <input type="checkbox"/> <input type="checkbox"/> | 24. |   |   |
| <input type="checkbox"/> <input type="checkbox"/> | 25. |   |   |
| <input type="checkbox"/> <input type="checkbox"/> | 26. |   |   |
| <input type="checkbox"/> <input type="checkbox"/> | 27. |   |   |
| <input type="checkbox"/> <input type="checkbox"/> | 28. |   |   |

\* Some models with an Engine Electronic Control Module (ECM) may limit or prohibit adjusting the engine speed or testing shutdowns. Refer to appropriate documentation available from the manufacturer.

START UP REQUEST PROCEDURE FOR KOHLER FACTORY ENCLOSED  
GENERATORS WITH FUEL TANK

ALL REQUESTS FOR START UP OF THE GENERATOR MUST ADHERE TO THE FOLLOWING  
PROCEDURES.

- 1 UPON COMPLETION OF ALL INSTALLATION, THE CONTRACTOR MUST COMPLETE THE PRE-START UP CHECKLIST AND EMAIL IT TO COOPER POWER SYSTEMS, ALONG WITH DESIRED START UP DATE.
  
- 2 PLEASE NOTE THAT A MINIMUM OF TWO (2) WEEKS NOTICE IS REQUIRED TO SCHEDULE ALL START-UPS AND LOAD BANK TESTS. A MINIMUM OF 48 HOURS IS REQUIRED TO CANCEL ALL START-UPS. IF START-UP OR LOAD BANK TEST IS CANCELLED WITHIN 48 HOURS, THERE WILL BE A \$1000 CANCELLATION FEE OR 1/2 DAY OF TECH TIME PLUS EQUIPMENT COSTS (IF ANY), WHICHEVER IS GREATER.
  
- 3 A COOPER PROJECT MANAGER CAN VISIT THE PROJECT SITE TO CONFIRM THAT THE GENERATOR INSTALLATION HAS BEEN COMPLETED AND TO ANSWER ANY QUESTIONS THAT MAY ARISE. THIS SHOULD BE SCHEDULED IN ADVANCE.
  
- 4 THE COOPER SCHEDULER WILL CONFIRM THE START UP DATE.
  
- 5 THE COOPER TECHNICIAN WILL ARRIVE ON SITE AT THE SCHEDULED DATE AND TIME TO PROVIDE THE START UP SERVICES.
  
- 6 ANY REPEAT CALLS BY OR CANCELLATIONS OF THE COOPER TECHNICIAN CAUSED BY INCOMPLETE INSTALLATION WILL BE CHARGED BACK TO THE CONTRACTOR AT THE STANDARD LABOR RATE INCLUDING ALL APPLICABLE TRAVEL EXPENSES.



**DIESEL GENERATOR SET  
PRE START UP CHECKLIST**

The following information is checklist must be completed and returned by email to your Cooper Power Systems project manager in order for start up to be scheduled.

		GENERATOR OWNER/END USER INFORMATION REQUIRED	
JOB NAME		CONTACT NAME	
DATE		CONTACT PHONE #	
JOB NUMBER		CONTACT EMAIL ADDRESS	
MODEL		SITE ADDRESS	
START UP DATE		SITE CITY, STATE, ZIP	
SERIAL NUMBER			
		CONTRACTOR CONTACT INFORMATION	
START-UP SITE CONTACT			
START-UP SITE PHONE			
SITE ADDRESS			

INSTALLATION OF THE GENERATOR AND ALL OF ITS ELEMENTS IS THE SOLE RESPONSIBILITY OF THE INSTALLING CONTRACTOR. COOPER IS NOT RESPONSIBLE TO THE INSTALLING CONTRACTOR OR ANY OTHER PARTY FOR THE FAILURE OF THE CONTRACTOR TO INSTALL THE GENERATOR AND ALL OF ITS ASSOCIATED COMPONENTS PROPERLY.

THE CHECKLIST IS MERELY A GUIDE TO PROPER INSTALLATION; IT DOES NOT INSURE PROPER INSTALLATION. THE INSTALLATION MUST BE IN STRICT COMPLIANCE WITH ALL CODES, STANDARDS AND REGULATIONS. IT WOULD BE IMPOSSIBLE TO PROVIDE DETAILS FOR EVERY INSTALLATION CONFIGURATION. FOR THIS REASON, MUCH OF THE INFORMATION PROVIDED IN THIS CHECKLIST IS GENERAL IN

BY AGREEING TO PERFORM THE START UP, COOPER IS NOT REPRESENTING OR WARRANTING THAT THE INSTALLATION IS CORRECT AND COMPLETE.

THE FOLLOWING ITEMS ARE THE RESPONSIBILITY OF THE INSTALLATION CONTRACTOR. IF THE COOPER TECHNICIAN CANNOT BEGIN THE START UP UPON ARRIVAL, AND REQUIRES AN ADDITIONAL SITE VISIT, AN AMMENDMENT TO THE ORIGINAL PURCHASE ORDER WILL BE REQUIRED.

# DIESEL GENERATOR SET - PRESTART CHECKLIST



## I FUEL SYSTEM

YES      NO      N/A

<input type="checkbox"/>	<input type="checkbox"/>	<input type="checkbox"/>
--------------------------	--------------------------	--------------------------

A. Storage tank filled with No. 2 diesel fuel.

## II ANCHORING

YES      NO      N/A

<input type="checkbox"/>	<input type="checkbox"/>	<input type="checkbox"/>
--------------------------	--------------------------	--------------------------

A. Generator / tank had been anchored down to Installation pad.

# DIESEL GENERATOR SET - PRESTART CHECKLIST



## III WIRING AND ELECTRICAL SYSTEM INTERCONNECTIONS

YES	NO	N/A	
<input type="checkbox"/>	<input type="checkbox"/>	<input type="checkbox"/>	A. All control wiring is complete and ready for checking by Cooper technician.
<input type="checkbox"/>	<input type="checkbox"/>	<input type="checkbox"/>	B. Remote Annunciators, when supplied, are installed and all interconnecting wiring completed.
<input type="checkbox"/>	<input type="checkbox"/>	<input type="checkbox"/>	C. All Main Power Connections are completed on any transfer switch, all control wiring run and connected between ATS and Generator set.
<input type="checkbox"/>	<input type="checkbox"/>	<input type="checkbox"/>	D. Customer Interface Module, or Customer Communications Modules, when supplied, are remote mounted and all Inter-connecting wiring completed.
<input type="checkbox"/>	<input type="checkbox"/>	<input type="checkbox"/>	E. All data link cabling and all types of DC communication (modbus, 485, 4-20ma, 1-5 volt signal, can1 or can2, Ethernet, CIM etc...) must be separated from any AC power source or AC conduit. Separate conduit is required.
<input type="checkbox"/>	<input type="checkbox"/>	<input type="checkbox"/>	F. Does this generator interface with a building management system or other devices that need to be interfaced with the generator controller or Remote annunciator? <b>IF YES: Please provide list of points to be monitored. Programming and point connections will be prepared during start up. SEE NEXT PAGE FOR LISTING INPUTS AND OUTPUTS which are required but are not provided with your system.</b>
<input type="checkbox"/>	<input type="checkbox"/>	<input type="checkbox"/>	J. If the generator is to be load tested using portable load banks, please advise the distance from the generator to the closest possible load bank location.

**NOTE: COOPER POWER WILL SUPPLY THE NECESSARY LOAD BANK CABLES. (50 Ft standard supply.) HOWEVER, IT IS THE CONTRACTOR’S RESPONSIBILITY TO RUN THE CABLES BETWEEN THE GENERATOR AND THE LOAD BANK, CONNECT THE CABLES AT THE GENERATOR, AND REMOVE & PREPARE THE CABLE FOR PICK UP BY COOPER POWER AFTER THE COMPLETION OF THE LOAD TEST. CUSTOMER IS RESPONSIBLE TO IDENTIFY A SAFE LOCATION FOR THE LOAD BANKS AS WELL AS MOVING THE LOAD BANKS TO THAT LOCATION.**

# DIESEL GENERATOR SET - PRESTART CHECKLIST



## IV SITE CONDITIONS

YES      NO      N/A

--

A. Is there adequate parking availability for the Cooper technicians vehicle on site? Must be within 50-100 feet of building entrance and/or generator location. **Additional charges will apply if special considerations need to be made. Contact your project manager if there is NOT adequate parking.**

--	--	--

B. Are there any safety considerations? Hardhat, visibilty vest, steel toed shoes. Please list them in the remarks box below.

ROOF	OUTSIDE	BASEMENT or BUILDING

C. Where is the generator located?

YES      NO      N/A

--	--	--

D. If roof mounted, is there a functioning elevator onsite? **The elevator must be available to the CPS technician to use.**

--	--	--

E. Are there any specific site requirements; OSHA card, TWIC, SWAC ETC. Please list them in the remarks box below.

--	--	--

F.

REMARKS:

# DIESEL GENERATOR SET - PRESTART CHECKLIST



After your complete review of what has been provided with your system,

- I Please List inputs from outside sources/devices that you wish to either annunciate or possibly control at the generator controller or route through the generator controller to the Remote Annunciator or BMS system.

Please do not include modbus points here.

Input Name	Type of Input Provided (+v, -v, Form 'C')

- II Please List outputs you require to be integrated with other equipment elsewhere in your power generation scheme.

Requested outputs from generator controller	Outputs will be Form 'C' contacts

Please note:

- Output Relay Contact Ratings
- 2A @ 120vac
- 2A @ 30vdc
- 2A @ 277vac

**DIESEL GENERATOR SET - PRESTART CHECKLIST**



REMARKS:

---

**I CERTIFY THAT THE ABOVE ITEMS HAVE BEEN COMPLETED TO THE BEST OF MY ABILITY AND THE GENERATOR IS READY FOR START UP BY A COOPER TECHNICIAN. I UNDERSTAND THAT IF THE START UP CANNOT BE COMPLETED BECAUSE OF AN INCOMPLETE INSTALLATION, A SERVICE CHARGE MAY APPLY.**

SIGNED

PRINT NAME

COMPANY NAME

DATE

---

**I CERTIFY THAT THE UNIT HAS BEEN INSTALLED AND CONNECTED AND IS READY FOR START UP.**

SIGNED

(COOPER PROJECT MANAGER)

PRINT NAME

(COOPER PROJECT MANAGER)

DATE

# Generator Training

Informal training is to be conducted during the start-up and will cover basic operation and maintenance practices. No attendance will be taken.

Training to be performed Monday – Friday during normal business hours.

Video taping of Cooper Power Systems Training is not permitted.

## Training Agenda



### **I. GENERATOR OVERVIEW**

- a. Safety features and emergency stop locations
- b. Package labels and accessory identification

### **II. CONTROL PANEL**

- a. Controller features
- b. Alarm indications & displays
- c. Shutdown indications & displays
- d. Electronic meter indications & displays
- e. Temperature / pressure indications & displays
- f. Factory presets & adjustments

### **III. REMOTE ANNUNCIATOR**

- a. Alarm indications & displays
- b. Programmable features & adjustments

### **IV. FUEL SYSTEM**

- a. Fuel fill and meter locations
- b. Low fuel & leak detection indications

**Distributor of KOHLER Generators • Transfer Switches • Switchgear • Rentals • UPS • Cogen**

## **V. ELECTRICAL ACCESSORIES**

- a. Battery charger overview & operation
- b. Battery / alternator / block heater operation
- c. Main circuit breaker operation

## **VI. MECHANICAL ACCESSORIES**

- a. Air cleaner location & maintenance
- b. Fuel filter location & maintenance
- c. Lube oil / filter / dipstick location & maintenance
- d. Cooling system maintenance & capacity



# O&M Manual

All O&M Manuals and warranty statements will be submitted electronically, no hard copies will be supplied unless otherwise noted.

## LOAD BANK TESTING

Included in the purchase of your Kohler generator is a load bank test. Load bank testing allows a standby generator to be tested and exercised to verify its overall reliability and its ability to run at its full rated kW output. During the generator load test, a Cooper Power technician monitors critical engine parameters such as: oil pressure, engine temperature, fuel pressure, etc.

Load bank testing is subject to weather permitting and safety considerations

### DURATION OF LOAD BANK TESTING

1. Two (2) Hour resistive load bank test.
2. Four (4) hour resistive load bank test.
3. Eight (8) hour resistive load bank test.
4. Twelve (12) hour resistive load bank test.
5. NFPA 110 resistive load bank test. This test is 2 hours in duration.
6. Custom load bank testing as per description below;

Special testing;

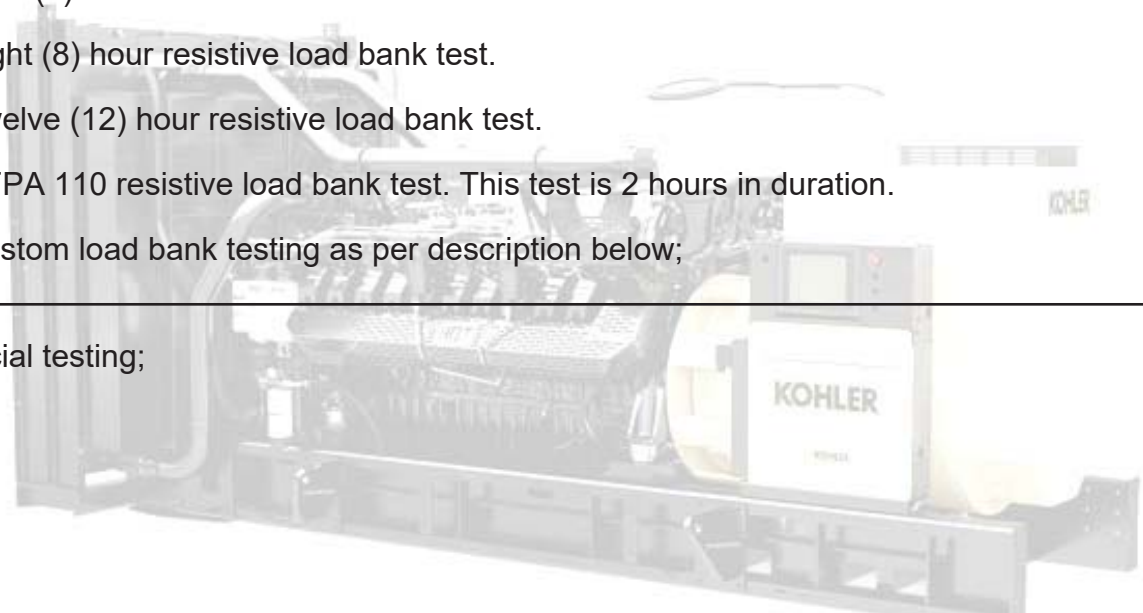

#### **Please Note;**

Customer is responsible to offload, un-crate, roll-out, connect, disconnect, roll-up, re-crate and reload all load bank cables between the generator and portable load bank(s). Additionally, customer is responsible to identify a safe location for the load banks to be set-up as well as moving the load banks to that location. Cooper Power Systems will provide the necessary number of lugs/pigtails for any load bank we provide for site. Cooper Power Systems is only responsible for cabling up to 50 feet in length unless otherwise agreed upon by Cooper Power Systems. Additional cabling can be quoted, as necessary. Extra charges will apply if the generator does not have free and clear access or if the cable length exceeds 50'. Disconnection and rolling of the cables are to be completed immediately following the load test to facilitate removal of the load bank(s) from site.



## KOHLER CO.

Kohler, Wisconsin 53044

Phone 920-457-4441, Fax 920-459-1646

For the nearest sales/service outlet in the  
US and Canada, phone 1-800-544-2444