

Carter



Submittal

1 - Caterpillar C32 (1250KW) Packaged Standby Generator Set

Project Number:
22-310CB

Carter Power Systems

6387 Old Washington Road, Elkridge MD 21075
Baltimore: 410-796-8000 1-800-443-9813 Fax: 410-379-0911

CARTER POWER SYSTEMS

TABLE OF CONTENTS

SUBJECT

SOURCE

SECTION 1 - GENERAL INFORMATION

Specification Clarifications	Carter Machinery Company
Air Permit Statement	Carter Machinery Company
Bill of Materials	Carter Machinery Company
Estimated Production Cycles	Carter Machinery Company
Generator Dimensions and Weights	Carter Machinery Company
Contractor Installation Requirements	Carter Machinery Company
Pre-Start-up Evaluation Form (Installing Contractor)	Carter Machinery Company
Check Test and Start-up Form	Carter Machinery Company
Load Test Report Form	Carter Machinery Company
Operation and Maintenance Training Form	Carter Machinery Company

SECTION 2 - PACKAGE TECHNICAL DATA

Caterpillar Model C32 1250 KW Package Brochure	Caterpillar LEHE20274
Engine Specific Performance Data	Caterpillar TMI Data
Generator Specific Technical Data	Caterpillar TMI Data
Voltage Regulator	Caterpillar LEHE20369
Governor	Caterpillar LEHE5347
Control Panel	Caterpillar LEHE2017

SECTION 3 - ACCESSORIES CUTSHEETS

Sound Attenuated Enclosure	Caterpillar LEHE20344
Circuit Breaker(s)	Caterpillar LEHE20289
Generator Space Heater	Caterpillar LEHE20379
Discrete I/O Module	Caterpillar LEHE2020
Remote Annunciator and Alarm Modules	Caterpillar LEHE2021
Remote Annunciator Wiring Diagrams	Carter Machinery Company
Recommended Cable for Remote Annunciator	Carter Machinery Company
Batteries	Caterpillar
Battery Charger	Caterpillar LEHE0140
Jacket Water Heater	Caterpillar LEHE20214
Warranty	Caterpillar
Extended Service Coverage	Caterpillar
Value Planned Maintenance	Carter Cat Power Systems

SECTION 4 - DRAWINGS

Layout Assembly Drawings	Caterpillar # 6311828
Electrical Interconnect Control Terminals	Caterpillar # 5990110
Schedule of Wiring Runs	Carter Machinery Company

SECTION 5 - ADDITIONAL POWER SYSTEMS ACCESSORIES

Custom UL2085 Sub-base tank	Global Power Components
Triple Breaker Docking Station	Power Temp Systems
Custom Access Stair and Platform	Redd Team

SUBMITTAL NOTES

This submittal provides detailed information based upon our best interpretation of the project requirements. Please check this submittal closely to verify dimensions, configurations, connection locations, capacities / performance, weights, etc. to be certain that all project requirements are met.

Equipment will ship to the project site based on that described in the final approved submittal.

Carter CAT Power Systems (CCPS) is an equipment supplier only and as such does not provide any field labor. The purchaser is responsible for all installation of the equipment described in this submittal. All equipment required to perform any loading /off-loading /manhandling / installation of the equipment and/or auxiliary items described in this submittal is the responsibility of the purchaser.

Though CCPS on occasion provides application information on their products, we are not responsible in any way for the design indicated in the contract documents.

The scope of supply is limited to the equipment and / or services described above. Equipment not indicated as being provided will be by others.

To prevent damage during transportation some items are shipped loose and should be installed, mounted, wired, piped, etc. by the installing contractor as part of unit installation.

Carter will provide time to time supervision, as required, of the work, performed by the installation contractor, of the generator and associated components. All tools and materials required to perform this work will be provided by the installation contractor.

This page intentionally left blank

CARTER POWER SYSTEMS

Section One GENERAL INFORMATION

Specification Clarifications

Air Permit Statement

Bill of Materials

Estimated Production Cycles

Generator Dimensions and Weights

Contractor Installation Requirements

Pre-Start-up Evaluation Form (Installing Contractor)

Check Test and Start-up Form

Load Test Report Form

Operation and Maintenance Training Form

This page intentionally left blank

SPECIFICATION CLARIFICATIONS

Clarifications/Exceptions:

- **We take exception to**
- **We take exception to Kohler Make and Model Numbers and are providing Caterpillar's standard product.**
- Regarding the NAVFAC testing in the specs. As typical, Carter Machinery is taking EXCEPTION to the following:
 - Grounding System – If required, this entire section is by others and not included. Deals with load cable insulation tests, grounding tests, etc. – all by others. Any measuring of ground impedance is by others and not included.
 - Functional Acceptance Tests- The alarms will be tested via the control panel by adjusting the set point of the alarm. No sensors will be removed from the system.
 - Functional Acceptance Tests- The over-speed trip on the generator will be simulated/performed through the control panel. Carter Machinery will not physically raise the speed of the engine.
 - Instructor's Qualification Resume- The training will be performed by a technician that has been certified by Caterpillar to work on Caterpillar generator sets.
 - NOTES - All work will be performed during normal working hours; M-F 7:30am to 4:00pm.
- **We are supplying a 105 Deg. C Alternator end and take exception to 12% Sub-Transient Reactance requirements.**
- Standard Clarifications: Rigging Diagram will not be on a "Metal Plate", the expansion tank will not be welded steel, and voltage adjustments will be done by push button from the control panel in lieu of Rheostat. No Analog Gages and/or meters are being supplied as we are providing a Digital Control panel, and Vibration Isolators will be installed between the Engine and generator frame rails.
- Noise level shall be as stated above, no guarantee is made of noise level at property boundaries.
- This proposal is confined to the Proposed Bill of Material above.
- All Design Calculations, Engineering, for anchorages and attachments, Noise levels, etc. are by others (if required).
- Installing contractor is responsible for rigging, assembly, installation, placards/signage unless included in the BOM of this proposal.
- All Permits, including Tank and Air Quality permitting, Utility charges/Fees (Electric, Phone, Gas, Cable, etc.), for any services are by others.
- We specifically exclude any special requirements or items not listed in above quote that the local AHJ's might impose or require for this project.
- Control Wiring Terminations are to be done by the installing contractor and will be checked by our technician.
- All field labor provided by others. All installation of this equipment shall be by others, including offloading, rigging, assembling the generator, enclosure to the Tank or Rails, all conduit, wire, concrete, anchors and in beds, Fuel, piping, duct work, exhaust piping, silencers, Remote E-Stops, Remote Annunciators and any other "Ship loose" items, etc. (unless noted otherwise).
- All fuel for initial fill and testing is to be provided by others.
- Surge Suppression, Lighting Protection and certification is by others.
- We are providing Manufacturer's standard mechanical lug configurations. Any deviations from standard lugs are the responsibility of the contractor.
- Federal, State and local code compliance is strictly the responsibility of the owner and his engineers and/or representatives.
- If the Buyer cannot accept delivery of the equipment and requests that the delivery be delayed by more than 2 weeks from the ready for shipment date, Carter Power Systems will invoice Buyer for the purchase price of the equipment and make arrangements for storage. Please refer to Carter Terms and Conditions for storage fees.
- Buyer may not cancel a purchase order, return equipment or change the delivery date without Carter's written consent. Any cancellation, return or change of delivery date is subject to additional charges based on Carter's costs.
- Carter makes no representation of outlined equipment's ability to fulfill requirements for EPA, State or Local emissions or any specific site requirements. Customer should contact local agencies to ensure equipment is compliant with applicable permitting requirements. If the authority having jurisdiction requires emission stack testing onsite, Carter Power Systems will provide a separate proposal for this service.
- All State and/or Local Sales taxes are not included in this proposal and must be paid to the appropriate agencies by others.
- We exclude Installation, Connections, Identification

CARTER POWER SYSTEMS

- We exclude Engineering, Installation, Connections, Identification, NETA Testing, ARC Flash Studies, Coordination Studies, 3 rd. Party Testing, Infrared scanning, Vibration Testing, Emissions Testing, Insulation Testing, Harmonic Testing, Noise level testing, Fuel consumption Testing, other Special Testing, Factory Witness Testing are not included. Please contact us for additional pricing.

This Project is confined to the Proposed Bill of Material as outlined within this submittal. Should something not be listed, do not assume that is or will be provided. Please check with CMCo's Project Manager for verification.

All field labor provided by others. Any and all installation of this equipment shall be by others.

Assembly of enclosure and /or enclosure accessories (on site) is not included in this proposal. Installing contractor is responsible for rigging, assembly and installation.

All fuel provided by others.

Items marked as ships loose on the Bill of Material to be installed by others.

Federal, State and local code compliance is strictly the responsibility of the owner and his engineers and/or representatives.

All permits; Air, Electrical, Mechanical, Fire, etc (unless stated here in) are the responsibility of others.

Title and risk of loss will pass to Buyer upon delivery of the equipment to project site or designated delivery address.

CARTER POWER SYSTEMS

SPECIFICATION CLARIFICATIONS

If the Buyer cannot accept delivery of the equipment and requests that the delivery be delayed by more than 2 weeks from the ready for shipment date, Alban Engine Power Systems will invoice Buyer for the purchase price of the equipment and make arrangements for storage. Please refer to CMCo Terms and Conditions for storage fees.

Buyer may not cancel a purchase order, return equipment or change the delivery date without Alban's written consent. Any cancellation, return or change of delivery date is subject to additional charges based on Alban's costs.

CMCo makes no representation of outlined equipments ability to fulfill requirements for EPA, State or Local emissions requirements. Customer should contact local agencies to ensure equipment is compliant with applicable permitting requirements.

This page intentionally left blank

Clean Air Act Compliance

Air Permits

Air permits are often required and must be issued before construction commences. Obtaining air permits is the responsibility of the owner or contractor. Air pollution control regulations may prevent delivery to the jobsite or installation of the equipment prior to issuance of the air permit.

To facilitate compliance with air pollution control regulations, CarterCAT Power Systems has qualified personnel who will perform an on-site inspection and will inquire about the air permit before a technician is sent to perform the start-up. CarterCAT Power Systems may not be able to start the engine until an air permit has been obtained, a waiver has been received from the permitting agency, or it is determined that an air permit is not required at this time.

Emission Testing (General requirements – may differ per site or testing agency)

If emission testing is required, the owner or contractor will be required to provide the following for the emission technician to be able to conduct the testing:

- One ½" port needs to be furnished in the exhaust stack located immediately after the engine exhaust connection; and
- Two 4" ports and two 1" ports, 90° apart, need to be equipped with removable covers and located at least two stack diameters down from the outlet of the exhaust.

These ports should be accessible from the roof of the enclosure/building. In all cases, the accessibility to the ports for the person operating the emission sampling probe must be an OSHA approved device. These devices can include a set of steps up to a platform, a man lift, or similar device. An A-frame ladder is an unacceptable device and cannot be provided to the probe operator.

If sampling is required, it must be performed within 180 days of startup or within 60 days of the unit reaching maximum rated power, unless otherwise stated in the air permit issued by the state regulatory agency. A stack sampling protocol is required to be submitted to the state air regulatory agency at least 30 days prior to testing and the report of the sampling results is due within 60 days of completion of the sampling.

When it comes to Clean Air Act compliance, many variables, such as the size and type of unit, as well as emission units already installed at the facility, will affect the type of air permit and whether emission testing is required. If you require assistance with Clean Air Act compliance, CarterCAT Power Systems has the necessary and qualified staff that can assist you.

This page intentionally left blank

CARTER POWER SYSTEMS

Bill of Materials

Manufacturer/ Part No.	Qty	Description	Ships
---------------------------	-----	-------------	-------

General

This submittal provides detailed information based upon our best interpretation of the project requirements. Carter CAT Power Systems does not represent that the items included in this submittal comply with any Plans and/or Specifications which may exist. Should we be required to comply with Plans and/or Specifications, we reserve the right to regard any changes required to comply as a Change Order. Please check this submittal closely to verify dimensions, configurations, connection locations, capacities/performance, weights, etc., to be certain that all project requirements are met.

Carter CAT Power Systems (CCPS) is an equipment supplier only and as such does not provide any field labor. The purchaser is responsible for all installation of the equipment described in this submittal. All equipment required to perform any loading / offloading / manhandling / installation of the equipment and/or auxiliary items described in this submittal is the responsibility of the purchaser.

Though CCPS on occasion provides application information on their products, we are not design consultants and, therefore, not responsible in any way for the design of the generator/switchgear whether or not indicated in the contract documents.

The scope of supply is limited to the equipment and/or services described below. Equipment not indicated as being provided will be by others.

To prevent damage during transportation some items are shipped loose and should be installed, mounted, wired, piped, etc., by the installing contractor as part of unit installation.

Package Generator Set

Caterpillar	1	C32	
	KW	1250	
	Duty	Standby	
	RPM	1800	
	Fuel	Diesel	
	Phase	3	
	Line Voltage	480	
	Phase Voltage	277	
	Hertz	60	
	Starting Voltage	VDC	

Generator is rated for Standby power - applicable for supplying power for the duration of an emergency outage at variable load with an average power output of 70% of standby rating [no overload permitted] with maximum expected usage of 500 hours per year.

EPA Emissions Certified Tier [2].

CARTER POWER SYSTEMS

Bill of Materials

Manufacturer/ Part No.	Qty	Description	Ships
<p>Generators described in this submittal will provide power to the system independent of other generators. CCPS will coordinate with the system integrator to establish components required such that they can deliver a complete and operable system to the user. The performance, features and components of the new generator[s] are fully described in this submittal. The following items which may be required for system integration <u>will be provided, installed and wired by others</u>: Current Transformers; Potential Transformers; Load Share Modules; Retrofit of components on existing generator[s] to achieve compatibility with those of the new generator[s]; Control Interface Devices.</p>			
Includes all standard equipment as indicated on the enclosed specification sheet			
Unit designed for outdoor installation on concrete pad provided by others.			
Please refer to Section 1 of this submittal for generator set dimensions and weights.			
Air Inlet System			
Caterpillar	1	Air Cleaner Assembly, Canister Type	
Charging System			
Caterpillar	1	Battery Charger, 110/120V, 208-240V, 60 Hz Input, 20 Amps, 24 VDC Output F/U/W Lead Acid / NiCad Batteries	Loose
Control System (governor)			
Caterpillar	1	ADEM A4 ECM, Speed Control Governor, Electronic 0% Regulation	
Cooling System			
Caterpillar	1	Radiator, Engine Mounted	
Caterpillar	1	Radiator Duct Flange	
Caterpillar	1	Coolant Level Sensor	
Caterpillar	1	Antifreeze, 50/50 Caterpillar Ethylene Glycol - Extended Life Coolant	Loose
Enclosures			

CARTER POWER SYSTEMS

Bill of Materials

Manufacturer/ Part No.	Qty	Description	Ships
Caterpillar	1	Standard Enclosure factory mounted on the generator, Sound Attenuated, manufactured from galvanized steel, color Cat White, provided with factory mounted exhaust system.	
Please refer to the attached cutsheets for additional information.			
Please refer to the attached drawings for additional information.			
Exhaust System			
Caterpillar	1	Dual Silencer, Industrial	
All urea is provided by others			
Fuel System			
Diesel Fuel		Total Circulated Fuel Flow required 227.2 GPH. (May be greater than 100% Fuel Consumption Rate)	
		Fuel Consumption Rate @ 100% Load 87.4GPH	
All Fuel Tanks and Fuel Transmission Systems are provided and Installed by others.			
All fuel is provided by others.			
NOTE: The required fuel for the engines on this project is Ultra Low Sulfur Fuel. This is fuel that has a sulfur content less than 15 ppm.			
Generator and Circuit Breakers			
Caterpillar	1	Generator	
		Model V12 GCAG	
		Frame E3875L4	
		Pitch 0.06667	
		Excitation Permanent Magnet	
Caterpillar	1	Digital Voltage Regulator	
Caterpillar	1	Space Heater; One 277 VAC, 60 Hz	
?	1	Circuit Breaker, Generator Mount, Bottom Entry, 2000 Amp, 100% Rated, LSIGP, W/Options:	
		Isolated Neutral	
		24 VDC Shunt Trip	
		One Set Of Auxiliary Contacts	

CARTER POWER SYSTEMS

Bill of Materials

Manufacturer/ Part No.	Qty	Description	Ships
Load Side Lugs provided and installed by others.			
Instrumentation & Controls			
Caterpillar	1	GCCP 1.2 Control Panel	
		Standard Features :	
		Run/Auto/Stop Control	
		Speed and Voltage Adjust	
		Local and Remote Emergency Stop	
		Remote Start/Stop	
		Cycle Crank	
		Electronic Display:	
		Oil Pressure	
		Coolant Temperature	
		RPM	
		Run Hours	
		Battery Voltage	
		AC Voltage	
		AC Amperage	
		Frequency	
		Average kW, kVA, kVA	
		Average Power Factor	
		Total kW-hr, kVA-hr	
		Stator and Bearing Temperature	
Caterpillar	1	EMCP 4 RS-485 Remote Annunciator, 16 Point, 32 Light	Loose
Protection Devices And Indication (See Annunciation List)			
Lube System			
Caterpillar	1	Lube Oil	
Caterpillar	1	Oil Pan Drain Valve	
Caterpillar	1	Fumes Disposal Hoses	Loose
Mounting System			
Global Power Componets	1	Fuel Tank Base, 24 hour tank	
Protection System			
Caterpillar	1	Engine Shutdown Sensors; Low Oil Pressure, High Coolant Temperature, Overspeed	
Caterpillar	1	Engine Pre-Alarm Sensors; Low Oil Pressure, High Coolant Temperature	
Caterpillar	1	Low Coolant Temperature Sensor	

CARTER POWER SYSTEMS

Bill of Materials

Manufacturer/ Part No.	Qty	Description	Ships
Caterpillar	1	Low Coolant Level Sensor	
Caterpillar	1	Battery Voltage: Low, High and Weak	
Caterpillar	1	Generator Protection:	
		Over/Under Voltage	
		Over/Under Frequency	
		Overcurrent	
		Reverse Power	
		Generator Phase Sequence	
Starting System			
Caterpillar	1	Electric; 24 VDC Automatic	
Caterpillar	1	Jacket Water Heater; Single 6 KW, 240 VAC, 60 Hz, Single Phase	
Caterpillar	1	Set Batteries; Wet, 24 VDC, 190 Amp\Hr, 2-4D's per set, high output, 1300CCA	
Caterpillar	1	Set Battery Cables; 2 To Engine And 1 Interconnect	Loose
Caterpillar	1	Battery Rack	Loose
Transfer Switches			
Power Temp Systems	1	2000A 480/277 Dual Purpose Pad Mount 3 Tier QC Panel w/ Dual TKI Isolation Breakers and Load Dump Breaker, 45 Degree Angled Male Cam-Loks, Padlockable and Tamper Resistant While In Use, External Female Load Bank Cam-Loks w/ Flip Covers and Padlockable Cover Door, 100 kA Rated, Plated Copper T-Slot Buss w/ Mechanical lugs, 2 Wire Auto Start Terminals w/ Signal Destination Switch, Phase Rotation Monitor, Bottom Back and Side Conduit Access, POWder Coated Aluminum w/ Side and Back Access Plates, cETLus Listed Conforms to UL STD 1008, Certified to CAN/CSA STD C22.2 NO. 178 20A GFCI with Breaker (120V external power required) 30A L530 Block Heater Receptacle with Breaker (120V external power required)	Loose

CARTER POWER SYSTEMS			
<u>Bill of Materials</u>			
Manufacturer/ Part No.	Qty	Description	Ships
System Check, Test and Start-up			
Carter Cat Power Systems (CCPS)		CCPS will provide time-to-time supervision, as required, of the work performed by the Installation Contractor for the System Check, Test and Start-up of the generator system provided under this contract. All tools required to perform this field work will be provided by the Installation Contractor.	
		Material provided by CCPS for the System Check, Test and Start-up will be received by the Installation Contractor and positioned in locations indicated by CCPS.	
		Prior to calling Carter for start-up, the installing contractor should:	
		-Review the "Contractor Installation Requirements" included in this submittal.	
		-Fill out the "Installing Contractor Pre-Start-Up and Testing Site Evaluation" included in this submittal and forward to your Carter Cat Project Manager.	
		CCPS will perform Installation Test described in Section 17.13 NFPA 110 / 2005 Installation Acceptance, which will be part of the Load Testing listed below.	
Load Testing			
		All fuel is provided by others. <u>ULTRA LOW SULFUR FUEL is required.</u>	
Carter Cat Power Systems (CCPS)		CCPS will provide a service technician to perform an 8 hour FWT hosted at our facility in Elkridge to perform the load test. A second 4 hour load test will be performed onsite after the completion of start up. Please refer to the sample "Load Testing Form" provided in this submittal indicating the readings that will be documented.	
		1250KW of 480 VAC Reactive Load Bank will be provided by CCPS for both the 8 hour FTW and 4 hour onsite test. All offloading/rigging required to position the load bank(s) close to the generators and all rigging/loading required to return the load bank(s) to the original delivery point will be the responsibility of the installing contractor.	
		-A maximum of 50ft. of cables will be delivered to the site by CCPS to connect the load banks to the generator. CCPS will supervise the work performed by the contractor for the offloading/onloading/rigging/laying of cables and making electrical terminations between the generator and load bank or building electrical equipment.	

CARTER POWER SYSTEMS

Bill of Materials

Manufacturer/ Part No.	Qty	Description	Ships
		-Load Test will be conducted using the building loads. Load banks will not be provided. The contractor has the responsibility to deliver sufficient load for the testing to be successfully completed. If it is later determined that the building cannot provide the load required for testing, CCPS can provide load banks at additional cost.	
		Load Bank Testing steps to be provided by customer prior to start up.	
Operation & Maintenance Manuals			
Caterpillar	1	Manual will be provided for use by the owner and for use during Instruction. <u>O&M Manuals will be manufacturer's standard.</u>	Loose
Instruction			
		Instruction of Owner's personnel in the operation and maintenance of the packaged generator using the O&M Manuals described above.	
Carter		CCPS will provide 1 Hour of on-site training IMMEDIATELY after completion of Load Bank Testing. A copy of the "Operation and Maintenance Training Form" describing the content of the training is included in this submittal	
		Training / Demonstration will be provided immediately following the completion of the startup / load bank testing.	
Warranty			
Standard Warranty: Caterpillar will, at it's option, repair or replace items found to be defective in material or workmanship for a period of Standby Operation - 24 months from Start-up not to exceed 500 hours per annum.			
Extended Service Coverage: Caterpillar will, at it's option, repair or replace items found to be defective in material or workmanship for a period of Standby Operation - 60 months from shipment not to exceed 500 hours per annum.			
Warranty covers All equipment provided by Caterpillar with the exception of consumables (filters, fluids, belts, hoses, power take offs, paint, batteries, clutches, etc.).			
All "Covered Components" must pass inspection or be replaced at the proper intervals as prescribed by the Operations and Maintenance Manual by an "Authorized Dealer" to qualify for continued coverage under the Service Contract. Failure to follow the Operations and Maintenance Manual may result in denial of claims.			
Value Planned Maintenance			
Carter CAT Power Systems will provide a CSA for one year which will include four visits to the site per engine. All filters will be replaced and lube oil will be changed on the fourth visit.			

CARTER POWER SYSTEMS

Bill of Materials

Manufacturer/ Part No.	Qty	Description	Ships
NOTE: All loose items are to be installed, fixed, filled, wired, etc., by the Contractor as part of unit installation.			



Dimensions, Weights and Rigging Procedures

Dimensions and Estimated* Rigging Weights

*Weights are ESTIMATED and are generally within +/-10%. If you require very accurate weights, please contact your Alban Project Manager.

Unit #1 350 kw

Shipping Section	Width (in.)	Length (in.)	Height (in.)	Estimated* Rigging Weight
Generator	91	244	104	20878
Tank	97.5	285	140	15500

Units that ship in multiple sections are to be joined together or erected by the Installation Contractor as part of the unit installation.

OFF LOADING AND RIGGING INFORMATION

- 1 All off loading and rigging is performed by others. Off loading/Rigging must be performed in a manner that is safe and does not damage the equipment. If you require any information that is not in this submittal and required to safely unload/rig the unit, Please contact your Alban Project Manager and that information will be provided to you.
- 2 Generator packages and integral Generator/Enclosure Packages are provided with lifting lugs at the base rail. These lifting lugs **MUST** be used. When units are lifted using base mounted lifting lugs, the use of spreader bars and fabric scraps are required to protect the equipment. Do not lift without spreader bars or with chains or metal cable as this will damage the equipment.
- 3 Drop over Enclosures are generally provided with lifting lugs at the enclosure roof. Spreader bars and fabric straps are recommended for these applications.

Under NO CIRCUMSTANCES should a unit carrying fuel be lifted.

Carter

Estimated Production Cycles

The following are our best estimates of equipment production cycles. The cycles begin upon our receipt of approved submittals and the purchaser's instruction to release equipment to production.

The production cycles indicated do not include any plant closings, such as during Thanksgiving and December Holidays, and any scheduled plant shutdowns.

EQUIPMENT	EST. WEEKS
Generator Set w/ Enclosure	54-56 weeks
Docking Station	TBD
Fuel Tank	16-18 weeks
Stairs and Platform	14-16 weeks

All shipping dates are estimated and start after receipt of approval submittal drawings

We will provide more accurate estimates after the equipment is placed into production.

CONTRACTOR INSTALLATION REQUIREMENTS

1. General

Carter Power Systems (CCPS) is an equipment supplier and does not provide any field labor. All off-loading, rigging and installation of the equipment defined in this submittal is performed by others. Unless specifically stated as being provided by CCPS in this submittal, all wiring between the generators, transfer switches, switchgear, annunciator panels and other auxiliaries either provided by CCPS or others is the responsibility of the installing contractor(s).

Though CCPS on occasion provides application information on their products, we are not responsible in any way for the design indicated in the contract documents for To avoid damage during transportation, some items will ship loose and are to be mounted, wired, piped, etc. by the installing contractor as part of the equipment installation process.

2. Delivery and Acceptance at Site

If items are damaged during transit, the receiver should fully describe the damage on the bill of lading or the CCPS ship ticket. Both the receiver and the trucker should then sign and date the paperwork. To avoid damage, transfer switches should always be transported vertically. ***If “tip and tell” is indicating that the ATS has been transported horizontally, mark it on the bill of lading and call your CCPS project manager before accepting the delivery.*** CCPS will not be responsible for any damages to the surrounding terrain incurred during delivery or off loading of the equipment. Overseeing the movement and routing of the equipment is the responsibility of the installing contractor

3. Support for Equipment

Foundation pads, structural support steel, concrete curbing are designed, provided and installed by others. Supports must be designed to carry the static / dynamic loads of the generator and it's auxiliaries plus, if installed outdoors, wind and snow loading. Units shall be supported around the full perimeter of the base rails. The maximum unsupported span across the unit width should not exceed 96". Units that ship in multiple sections shall be supported at each section split.

When pad mounted, pads should extend a minimum of 12" beyond the unit enclosure. Flashing between the unit base and curbing, if required, will be provided and installed by others. Pads to be level to within 1/8" across the length and width of the generator and there shall not be deviations in height greater than 1/16".

4. Electrical Stub-Ups

All stub-up information can be found on the drawings provided. Prior to offloading, the contractor should verify that the locations indicated on the submittal match those on the actual shipped product.

5. Unloading and Rigging

Please refer to the weights and dimensions indicated in this submittal. If you require any information that is not in the submittal and is necessary for safe off loading / rigging of the unit, please call the CCPS project engineer and it will be provided to you. Off loading / rigging must be performed in a manner which does not damage the equipment. The use of spreader bars and slings will be required when equipment is rigged from above. The installing contractor is responsible for any damage incurred during off loading and rigging.

6. Power Requirements

If provided, items such as jacket water heaters, battery chargers, day tank motors, enclosure space heaters, etc., require remote power provided by others. Please refer to the submittal for details on voltages and load requirements.

7. Electrical Wiring

Due to normal vibrations, all electrical connections to the generator shall be minimum 3' long flex.

8. Fuel System

Due to normal vibrations, all fuel connections to the generator must be via flexible lines. All fuel is provided by others.

Unless specifically stated as being provided in this submittal, all fuel piping and fuel train devices are provided and installed by others.

Gas

When the generator is fueled by gas, a flexible gas line will be provided by CCPS and shipped loose for mounting by the installing contractor.

Confirm that the gas service provided to the generator is within the operating pressure range indicated in the submittal.

The gas regulator valve and other elements of the gas train are provided and installed by the installing contractor. The regulator must be provided with a positive dead end lockup where reduced pressure is maintained at the regulator discharge under static conditions when no gas is flowing to the generator. If the pressure at the discharge of the regulator rises to input line pressure, the generator will start, go into an over-speed condition due to the high pressure and go out on over-speed safety.

Regulator valves shall be installed with a drip leg at the inlet to decrease the possibility of contaminants entering the valve.

The gas train to be selected based on:

- Maximum Engine Fuel Consumption
- Engine Turn-down Ratio
- Minimum gas pressure required at Engine

Since these requirements vary with Engine type, please contact the Alban Project Manager for the information specific to this job.

The gas regulator must be able to respond to pressure and load variations faster than the engine to ensure that the supply pressure at the engine gas inlet:

- Does not fall below the minimum pressure during sudden load changes causing poor engine response or engine shutdown.
- Does not fluctuate by more than 0.25 psig under steady state conditions.

To achieve the required gas pressures at the engine inlet, a constant gas pressure must be provided upstream of the pressure regulator.

For high pressure gas systems (with minimum gas pressure generally above 10 psig) the gas pressure to the regulator should not vary by more than +/-1 psig.

For low pressure systems (with minimum gas pressures at 1.0 to 1.5 psig) the gas pressure to the regulator should not vary by more than +/-0.25 psig.

For generator systems where rapid load changes are possible, such as on standby applications:

Load changes must be sequenced (stepped) such that each variation does not exceed 30% of full load output.

An accumulator tank sized for 15 seconds of engine full load gas consumption can be installed upstream of the gas pressure regulator to maintain gas pressure within the required tolerances.

Gas train is to be as close as possible to the Engine.

Provide pressure gauges at beginning and end of the gas train.

Any Flow Management Stations are to be mounted on the high pressure side of the system. If the gas train must be more than 10 ft. from the Engine, precautions must be taken to assure that proper gas pressure is delivered to the engine at the proper tolerance.

Pressure Regulator, pressure relief valves and any other elements which expel gas must be vented to atmosphere.

Diesel Fuel

Units with sub base fuel tanks should be filled with fuel after installation. ***Never attempt to lift a generator when the sub base tank has fuel in it.***

Fuel piping should be the same material as the tanks, either black iron or steel. Extend normal vent lines as required by local code(s).

Do Not Use zinc alloy or galvanized pipe as the fuel will react with these metals causing premature deterioration.

When a main tank is above a day tank, we strongly recommend an emergency return pump be installed to limit the possibility of a fuel spill.

9. Exhaust System

Connection between the generator and the exhaust system must be flexible.

Mufflers must be properly supported by others in a manner which does not apply any weight loading to the engine.

When the mufflers are located in the engine room, we suggest that they be thermally insulated.

10. Ventilation System

When units are enclosed within a room, the ventilation system must provide the appropriate amount of ventilation air at the intake grills to the alternator, across the engine block and at the combustion air intake filters at a maximum temperature of 115°F.

Generators located inside an engine room and provided with integral radiators require the airflow indicated in the submittal performance data to provide enough air for the radiator, to remove the heat coming off the engine block, and for the combustion air. Ideally, cool, dry, clean air should enter the engine room as close to the floor as possible, flowing first across the alternator then to both sides of the engine, discharge through the radiator and exit the room.

If the radiator fan is the only air moving element in the system, the pressure drop of the components external to the radiator exchanger must not exceed the static capability of the fan which is 0.50" W.G. As a quick rule-of-thumb, if the intake and exhaust components (louvers, dampers, etc.) have a face area more than 1.5 times the face area of the radiator core, the pressure drop often will not exceed 0.50" W.G. If the installation includes filters or filter racks, be concerned as the pressure drop of dirty filters can easily exceed 0.50" W.G.

Generators with remote radiators require powered air moving devices to provide sufficient flow across the engine to remove the heat emanating from the engine block and for combustion air. The heat of the engine block is indicated in the submittal performance data. Ideally, cool, dry, clean air should be powered into the engine room as close to the floor as possible, flowing first across the alternator then to both sides of the engine and exhaust from the space in a location above the engine.

Generators located outdoors in Enclosures should be located such that the appropriate service clearances, door swing areas and ventilation air intake and exhaust paths are provided. Contact the Alban Project Manager if you have any questions.

11. Lubrication System

Remove the shipping plugs from the crankcase breather tubes. Breather pipe hoses to be connected and routed smoothly such that they discharge at building exterior.

12. Engine Coolant System

When remote radiators are provided:

If air to air type, the pipe runs must be extremely short with limited number of fittings. Contractor must provide a dimensioned sketch to Alban for approval prior to running pipe. If water to air type the expansion tank must be located at the highest point in the system. This may involve raising the height of the radiator or removing the expansion tank from the radiator and mounting it separately.

All pipe, piping specialties are provided and installed by the Installation Contractor. After installation is complete, the Installing Contractor is to pressure test and clean out the system.

Charging the system with Glycol/Water, provided by others is the responsibility of the Installing Contractor.

13. Control Wiring

Control wiring must be run in conduit separate from any AC power wiring to prevent induced voltages from affecting the control signals.

Please refer to the schedule of wire runs provided with this submittal.

All wiring is to be resistant to fuel and oil and have a temperature range of 40°C – 125°C.

All analog control / power wires must be copper stranded type, 14-gauge minimum or larger as required to limit the voltage drop to 10% across length of run.

All digital communication wiring must be 2-wire shielded twisted, Northwire DataCELL J1939 part number FJ1939182-005 or equivalent.

14. Remote Annunciator Wiring (refer to control wiring above for wire requirements)

When the generator is equipped with an EMCP 4 control panel an EMCP-4 remote annunciator with 16 points of annunciation and 2 LED lights per point is provided:

This requires (1) digital communication wire, Northwire DataCELL J1939 part number FJ1939182-005 or **Belden 8770** or equivalent, and (2) analog control / power wires for power. When the remote annunciator is the device on the communications link furthest from the generator terminal strip, a 0.5W, 120 ohm termination resistor must be wired at the annunciator.

Polarity on the communication line is very important. Select white as positive and black as negative.

Maximum run is 800 ft.

In general, control interface is via Modbus 485 protocol through RS 485 connections provided by others. Please refer to the control panel specification sheet included in this submittal for specific details. All terminal strips, relays etc. will be provided and installed by others.

This page intentionally left blank



Site and Equipment Inspection / Accessibility

	OK	NO	N/A	Comments
Any visible Damage	<input type="checkbox"/>	<input type="checkbox"/>	<input type="checkbox"/>	<input type="checkbox"/>
All equipment easily assessable	<input type="checkbox"/>	<input type="checkbox"/>	<input type="checkbox"/>	<input type="checkbox"/>
Area clean of all debris / dirt / etc.	<input type="checkbox"/>	<input type="checkbox"/>	<input type="checkbox"/>	<input type="checkbox"/>
Security clearance required?	<input type="checkbox"/>	<input type="checkbox"/>	<input type="checkbox"/>	<input type="checkbox"/>
Permanent access to:				
Control panels, switchgear and / or ATS(s)	<input type="checkbox"/>	<input type="checkbox"/>	<input type="checkbox"/>	<input type="checkbox"/>
All filters: air, fuel, oil, water	<input type="checkbox"/>	<input type="checkbox"/>	<input type="checkbox"/>	<input type="checkbox"/>
Piping valves and solenoids	<input type="checkbox"/>	<input type="checkbox"/>	<input type="checkbox"/>	<input type="checkbox"/>
Fuel priming pump	<input type="checkbox"/>	<input type="checkbox"/>	<input type="checkbox"/>	<input type="checkbox"/>
Day tank controls	<input type="checkbox"/>	<input type="checkbox"/>	<input type="checkbox"/>	<input type="checkbox"/>
Day tank fuel fill port	<input type="checkbox"/>	<input type="checkbox"/>	<input type="checkbox"/>	<input type="checkbox"/>
Temporary access for:				
Placing Portable Load bank(s)	<input type="checkbox"/>	<input type="checkbox"/>	<input type="checkbox"/>	<input type="checkbox"/>
Load cables, routing, and connection	<input type="checkbox"/>	<input type="checkbox"/>	<input type="checkbox"/>	<input type="checkbox"/>
Technician truck(s) parking	<input type="checkbox"/>	<input type="checkbox"/>	<input type="checkbox"/>	<input type="checkbox"/>

Comments:

Enclosure Mounting:

	OK	NO	N/A	Comments
Enclosure or fuel base tank is mounted on vibration isolators (spring or rubber)	<input type="checkbox"/>	<input type="checkbox"/>	<input type="checkbox"/>	<input type="checkbox"/>
Vibration isolators are located properly	<input type="checkbox"/>	<input type="checkbox"/>	<input type="checkbox"/>	<input type="checkbox"/>
Mounting pad is level to within 1/8" across generator length and width	<input type="checkbox"/>	<input type="checkbox"/>	<input type="checkbox"/>	<input type="checkbox"/>
Mounting pad is proper thickness for support	<input type="checkbox"/>	<input type="checkbox"/>	<input type="checkbox"/>	<input type="checkbox"/>
Appropriate hold down bolts used for isolators and/or for mounting of enclosure to mounting pad	<input type="checkbox"/>	<input type="checkbox"/>	<input type="checkbox"/>	<input type="checkbox"/>
Flexible connections to genset	<input type="checkbox"/>	<input type="checkbox"/>	<input type="checkbox"/>	<input type="checkbox"/>
Proper free air clearance all around genset	<input type="checkbox"/>	<input type="checkbox"/>	<input type="checkbox"/>	<input type="checkbox"/>
All shipped loose items installed, i.e., exhaust elbow, rain cap, rain shield exterior lighting, air intake / discharge hoods, sound baffles, platforms & stairs, battery racks and batteries	<input type="checkbox"/>	<input type="checkbox"/>	<input type="checkbox"/>	<input type="checkbox"/>
Crankcase vent hoses installed and ran to exterior	<input type="checkbox"/>	<input type="checkbox"/>	<input type="checkbox"/>	<input type="checkbox"/>

Comments:



Ventilation:	OK	NO	N/A	Comments
Air louvers in place and clear of shipping braces	<input type="checkbox"/>	<input type="checkbox"/>	<input type="checkbox"/>	<input type="checkbox"/>
No obstructions within 10 feet (free air) of air intake or radiator discharge	<input type="checkbox"/>	<input type="checkbox"/>	<input type="checkbox"/>	<input type="checkbox"/>
Condensate trap properly located and installed	<input type="checkbox"/>	<input type="checkbox"/>	<input type="checkbox"/>	<input type="checkbox"/>
Provisions exist for supplying the proper amount of cooling air, at a maximum temperature of 100°F for engine intake air and to remove the radiated heat from the engine block and from the exhaust system	<input type="checkbox"/>	<input type="checkbox"/>	<input type="checkbox"/>	<input type="checkbox"/>
<i>Refer to the specification sheet within the Submittal for airflow recommendations</i>				
All screens on intake and discharge louvers in place	<input type="checkbox"/>	<input type="checkbox"/>	<input type="checkbox"/>	<input type="checkbox"/>
Sufficient air inlet size for necessary air into room	<input type="checkbox"/>	<input type="checkbox"/>	<input type="checkbox"/>	<input type="checkbox"/>
Louver dampers are powered and operating properly	<input type="checkbox"/>	<input type="checkbox"/>	<input type="checkbox"/>	<input type="checkbox"/>
Louver and fans wired: powered to close, failed to open	<input type="checkbox"/>	<input type="checkbox"/>	<input type="checkbox"/>	<input type="checkbox"/>
<u>Comments:</u>				

Generator Mounting:	OK	NO	N/A	Comments
Genset or fuel base tank is mounted on vibration isolators (spring or rubber)	<input type="checkbox"/>	<input type="checkbox"/>	<input type="checkbox"/>	<input type="checkbox"/>
Vibration isolators are proper location	<input type="checkbox"/>	<input type="checkbox"/>	<input type="checkbox"/>	<input type="checkbox"/>
Vibration isolation shipping blocks & hold-downs removed	<input type="checkbox"/>	<input type="checkbox"/>	<input type="checkbox"/>	<input type="checkbox"/>
Spring Isolators are adjusted for height & deflection	<input type="checkbox"/>	<input type="checkbox"/>	<input type="checkbox"/>	<input type="checkbox"/>
Floor mounting pad is level to within 1/8" across generator length and width	<input type="checkbox"/>	<input type="checkbox"/>	<input type="checkbox"/>	<input type="checkbox"/>
Floor mounting pad is proper thickness for support	<input type="checkbox"/>	<input type="checkbox"/>	<input type="checkbox"/>	<input type="checkbox"/>
Appropriate hold down bolts used for isolators and for mounting of genset to fuel base tank	<input type="checkbox"/>	<input type="checkbox"/>	<input type="checkbox"/>	<input type="checkbox"/>
Flexible connections to genset	<input type="checkbox"/>	<input type="checkbox"/>	<input type="checkbox"/>	<input type="checkbox"/>
Crankcase vent hoses installed and ran to exterior	<input type="checkbox"/>	<input type="checkbox"/>	<input type="checkbox"/>	<input type="checkbox"/>
Proper free air clearance all around genset	<input type="checkbox"/>	<input type="checkbox"/>	<input type="checkbox"/>	<input type="checkbox"/>
<u>Comments:</u>				



Engine Exhaust System:

	OK	NO	N/A	Comments
Silencer properly located and connected	<input type="checkbox"/>	<input type="checkbox"/>	<input type="checkbox"/>	<input type="checkbox"/>
Muffler is properly supported from the enclosure structure or Building structure without the weight bearing on the exhaust flange of the engine	<input type="checkbox"/>	<input type="checkbox"/>	<input type="checkbox"/>	<input type="checkbox"/>
NOTE: It is the contractor's responsibility to install shipped loose mufflers and flex connections				
Exhaust piping is secure, properly supported and piped to the exterior with a rain cap installed	<input type="checkbox"/>	<input type="checkbox"/>	<input type="checkbox"/>	<input type="checkbox"/>
Flexible fittings are installed at the engine to isolate the engine vibration from the exhaust system piping	<input type="checkbox"/>	<input type="checkbox"/>	<input type="checkbox"/>	<input type="checkbox"/>
Only long radius "sweep" elbows are used in the exhaust system and there are no system restrictions.	<input type="checkbox"/>	<input type="checkbox"/>	<input type="checkbox"/>	<input type="checkbox"/>
System must be below the allowable backpressure limit.	<input type="checkbox"/>	<input type="checkbox"/>	<input type="checkbox"/>	<input type="checkbox"/>
Exhaust piping discharge is positioned away from outside "ventilation" air intakes to the building, generator air intakes and radiator inlets	<input type="checkbox"/>	<input type="checkbox"/>	<input type="checkbox"/>	<input type="checkbox"/>
Exhaust piping is positioned away from the generator control panel to protect it from any heat related damage to the electronic circuitry	<input type="checkbox"/>	<input type="checkbox"/>	<input type="checkbox"/>	<input type="checkbox"/>
Exhaust piping includes all necessary expansion joints required to compensate for thermal growth	<input type="checkbox"/>	<input type="checkbox"/>	<input type="checkbox"/>	<input type="checkbox"/>
Exhaust insulation installed	<input type="checkbox"/>	<input type="checkbox"/>	<input type="checkbox"/>	<input type="checkbox"/>

Comments:

Lubrication System:

	OK	NO	N/A	Comments
Shipping plugs removed from crankcase breather	<input type="checkbox"/>	<input type="checkbox"/>	<input type="checkbox"/>	<input type="checkbox"/>
Crankcase breather pipe hoses connected and routed smoothly to discharge to building exterior	<input type="checkbox"/>	<input type="checkbox"/>	<input type="checkbox"/>	<input type="checkbox"/>
Crankcase sump full of oil – verify using dipstick	<input type="checkbox"/>	<input type="checkbox"/>	<input type="checkbox"/>	<input type="checkbox"/>
No visible oil leaks	<input type="checkbox"/>	<input type="checkbox"/>	<input type="checkbox"/>	<input type="checkbox"/>
Oil make-up system installed, filled and operational	<input type="checkbox"/>	<input type="checkbox"/>	<input type="checkbox"/>	<input type="checkbox"/>
Verify oil dipstick is properly seated after crank case check	<input type="checkbox"/>	<input type="checkbox"/>	<input type="checkbox"/>	<input type="checkbox"/>

Comments:



Diesel Fuel System:

	OK	NO	N/A	Comments
Flexible fuel lines used to all connections on the Generator Set	<input type="checkbox"/>	<input type="checkbox"/>	<input type="checkbox"/>	<input type="checkbox"/>
Fuel day tank plumbed to engine	<input type="checkbox"/>	<input type="checkbox"/>	<input type="checkbox"/>	<input type="checkbox"/>
Fuel day tank plumbed to main tank	<input type="checkbox"/>	<input type="checkbox"/>	<input type="checkbox"/>	<input type="checkbox"/>
Fuel lines are to match the material of the tank, either black iron or steel.	<input type="checkbox"/>	<input type="checkbox"/>	<input type="checkbox"/>	<input type="checkbox"/>
NOTE: Zinc alloy or galvanized pipe should not be used as it will react with the fuel				
Plumbed fuel supply lines are correct size	<input type="checkbox"/>	<input type="checkbox"/>	<input type="checkbox"/>	<input type="checkbox"/>
Fuel return line has been checked from engine to day tank and from day tank to storage tank to ensure that no restrictions exist	<input type="checkbox"/>	<input type="checkbox"/>	<input type="checkbox"/>	<input type="checkbox"/>
IMPORTANT: Restrictions in return line can cause severe damage to engine				
Confirm that there are no stop valves in the return line between the engine and day / main tank	<input type="checkbox"/>	<input type="checkbox"/>	<input type="checkbox"/>	<input type="checkbox"/>
IMPORTANT: If closed during operation, this will restrict flow and cause engine damage				
Fuel lines purged	<input type="checkbox"/>	<input type="checkbox"/>	<input type="checkbox"/>	<input type="checkbox"/>
Fuel tank vent lines installed properly	<input type="checkbox"/>	<input type="checkbox"/>	<input type="checkbox"/>	<input type="checkbox"/>
Fuel tank vent lines are correct height	<input type="checkbox"/>	<input type="checkbox"/>	<input type="checkbox"/>	<input type="checkbox"/>
Day tank pump operational	<input type="checkbox"/>	<input type="checkbox"/>	<input type="checkbox"/>	<input type="checkbox"/>
System pressure test completed	<input type="checkbox"/>	<input type="checkbox"/>	<input type="checkbox"/>	<input type="checkbox"/>
Fuel day tank full of fuel	<input type="checkbox"/>	<input type="checkbox"/>	<input type="checkbox"/>	<input type="checkbox"/>
No visible leaks in fuel day tank	<input type="checkbox"/>	<input type="checkbox"/>	<input type="checkbox"/>	<input type="checkbox"/>
All fuel alarms and monitoring connected	<input type="checkbox"/>	<input type="checkbox"/>	<input type="checkbox"/>	<input type="checkbox"/>
Water separators installed	<input type="checkbox"/>	<input type="checkbox"/>	<input type="checkbox"/>	<input type="checkbox"/>
Sufficient fuel available in main tank	<input type="checkbox"/>	<input type="checkbox"/>	<input type="checkbox"/>	<input type="checkbox"/>

Comments:

Natural or LP Gas Fuel System:

	OK	NO	N/A	Comments
Gas lines connected	<input type="checkbox"/>	<input type="checkbox"/>	<input type="checkbox"/>	<input type="checkbox"/>
Correct gas pressure regulator installed	<input type="checkbox"/>	<input type="checkbox"/>	<input type="checkbox"/>	<input type="checkbox"/>
What size is incoming gas line	<u>Inch</u>			
How long of a gas line run from Genset to main regulator	<u>Feet</u>			
Flexible connections between engine and piping	<input type="checkbox"/>	<input type="checkbox"/>	<input type="checkbox"/>	<input type="checkbox"/>
Gas meter (is used) connected to high pressure side of regulator	<input type="checkbox"/>	<input type="checkbox"/>	<input type="checkbox"/>	<input type="checkbox"/>
Dirt traps installed upstream of all Gas Regulators	<input type="checkbox"/>	<input type="checkbox"/>	<input type="checkbox"/>	<input type="checkbox"/>

Comments:



Cooling System:

	OK	NO	N/A	Comments
System full of proper antifreeze solution	<input type="checkbox"/>	<input type="checkbox"/>	<input type="checkbox"/>	<input type="checkbox"/>
Low level gauges installed and connected	<input type="checkbox"/>	<input type="checkbox"/>	<input type="checkbox"/>	<input type="checkbox"/>
Remote radiator pipes plumbed and valves installed	<input type="checkbox"/>	<input type="checkbox"/>	<input type="checkbox"/>	<input type="checkbox"/>
Expansion tanks are installed at the highest point in piping system	<input type="checkbox"/>	<input type="checkbox"/>	<input type="checkbox"/>	<input type="checkbox"/>
System is pressure tested at 15psi for a 24-hour period	<input type="checkbox"/>	<input type="checkbox"/>	<input type="checkbox"/>	<input type="checkbox"/>
No coolant leaks visible anywhere in system	<input type="checkbox"/>	<input type="checkbox"/>	<input type="checkbox"/>	<input type="checkbox"/>
Remote radiator fan motor starter wired	<input type="checkbox"/>	<input type="checkbox"/>	<input type="checkbox"/>	<input type="checkbox"/>
Electric discharge louvers connected	<input type="checkbox"/>	<input type="checkbox"/>	<input type="checkbox"/>	<input type="checkbox"/>
Radiator ducts properly sized	<input type="checkbox"/>	<input type="checkbox"/>	<input type="checkbox"/>	<input type="checkbox"/>
On cooling systems with remote radiators, the piping system has been designed such that no air will be trapped in the lines	<input type="checkbox"/>	<input type="checkbox"/>	<input type="checkbox"/>	<input type="checkbox"/>

Comments:

DC Electrical System:

	OK	NO	N/A	Comments
Battery racks installed and batteries in place	<input type="checkbox"/>	<input type="checkbox"/>	<input type="checkbox"/>	<input type="checkbox"/>
Battery cables connected	<input type="checkbox"/>	<input type="checkbox"/>	<input type="checkbox"/>	<input type="checkbox"/>
Battery charger installed and connected to power	<input type="checkbox"/>	<input type="checkbox"/>	<input type="checkbox"/>	<input type="checkbox"/>
<i>On batteries that are not sealed, do not energize battery charger until batteries have been filled with acid</i>				
Day tank solenoids installed and connected	<input type="checkbox"/>	<input type="checkbox"/>	<input type="checkbox"/>	<input type="checkbox"/>
Remote annunciator(s) installed and connected	<input type="checkbox"/>	<input type="checkbox"/>	<input type="checkbox"/>	<input type="checkbox"/>
Discrete Input/Output Module(s) (DIO) installed and connected	<input type="checkbox"/>	<input type="checkbox"/>	<input type="checkbox"/>	<input type="checkbox"/>
All DC wiring installed in dedicated conduit	<input type="checkbox"/>	<input type="checkbox"/>	<input type="checkbox"/>	<input type="checkbox"/>
All DC control wiring is stranded type	<input type="checkbox"/>	<input type="checkbox"/>	<input type="checkbox"/>	<input type="checkbox"/>
Engine start wires connected	<input type="checkbox"/>	<input type="checkbox"/>	<input type="checkbox"/>	<input type="checkbox"/>
Additional DC wiring installed as required	<input type="checkbox"/>	<input type="checkbox"/>	<input type="checkbox"/>	<input type="checkbox"/>

Comments:



AC Electrical System:

	OK	NO	N/A	Comments
Transfer switch(s) installed and connected	<input type="checkbox"/>	<input type="checkbox"/>	<input type="checkbox"/>	<input type="checkbox"/>
Power cables from genset connected	<input type="checkbox"/>	<input type="checkbox"/>	<input type="checkbox"/>	<input type="checkbox"/>
Control wiring to genset connected	<input type="checkbox"/>	<input type="checkbox"/>	<input type="checkbox"/>	<input type="checkbox"/>
Power wiring to jacket water heater connected	<input type="checkbox"/>	<input type="checkbox"/>	<input type="checkbox"/>	<input type="checkbox"/>
<i>Do not energize jacket water heater until the engine coolant has been installed</i>				
Power wiring to strip heaters connected	<input type="checkbox"/>	<input type="checkbox"/>	<input type="checkbox"/>	<input type="checkbox"/>
Power wiring to battery charger connected	<input type="checkbox"/>	<input type="checkbox"/>	<input type="checkbox"/>	<input type="checkbox"/>
Power wiring to fuel oil cooler connected	<input type="checkbox"/>	<input type="checkbox"/>	<input type="checkbox"/>	<input type="checkbox"/>
Power wiring to genset enclosure panel board connected	<input type="checkbox"/>	<input type="checkbox"/>	<input type="checkbox"/>	<input type="checkbox"/>
All AC wiring installed in dedicated conduit	<input type="checkbox"/>	<input type="checkbox"/>	<input type="checkbox"/>	<input type="checkbox"/>
All AC control wiring is stranded type	<input type="checkbox"/>	<input type="checkbox"/>	<input type="checkbox"/>	<input type="checkbox"/>
Generator grounding connected to common ground	<input type="checkbox"/>	<input type="checkbox"/>	<input type="checkbox"/>	<input type="checkbox"/>
Generator neutral connected to ground (If system is bonded)	<input type="checkbox"/>	<input type="checkbox"/>	<input type="checkbox"/>	<input type="checkbox"/>
All low voltage power wiring on the load side bus	<input type="checkbox"/>	<input type="checkbox"/>	<input type="checkbox"/>	<input type="checkbox"/>
Utility power available	<input type="checkbox"/>	<input type="checkbox"/>	<input type="checkbox"/>	<input type="checkbox"/>
All low voltage accessories energized	<input type="checkbox"/>	<input type="checkbox"/>	<input type="checkbox"/>	<input type="checkbox"/>
For voltages above 600 VAC, all cables and connected items to be hi-pot tested	<input type="checkbox"/>	<input type="checkbox"/>	<input type="checkbox"/>	<input type="checkbox"/>

Comments:

NOTE: To prevent damage during transportation, some items are shipped loose and should be mounted, wired, piped, etc. by the installing contractor as part of the unit installation procedure.



OPERATION AND MAINTENANCE TRAINING

Project #:

Project Name:

Date:

The following personnel were present for and completed Operation and Maintenance Training

<u>Trainee's Signature</u>	<u>Printed Name</u>	<u>Company</u>	<u>Position</u>	<u>Phone</u>
_____	_____	_____	_____	_____
_____	_____	_____	_____	_____
_____	_____	_____	_____	_____
_____	_____	_____	_____	_____

Confirm that the following systems were covered in the training.

<u>Description</u>	<input type="checkbox"/> <u>if Training Complete</u>
1. General Safe Operation Instructions	<input type="checkbox"/>
2. Identification of Major Genset Components	<input type="checkbox"/>
3. Major Equipment Identification	<input type="checkbox"/>
4. General Theory of Operation	<input type="checkbox"/>
5. Demonstrations of Various Modes	<input type="checkbox"/>
6. Air Filtration Filter Change Procedure and Interval	<input type="checkbox"/>
7. Battery Charger	<input type="checkbox"/>
8. Governor	<input type="checkbox"/>
9. Engine Cooling System	<input type="checkbox"/>
10. Radiator System	<input type="checkbox"/>
11. Silencer Drain	<input type="checkbox"/>
12. Engine Fuel Filter Change Procedure and Interval	<input type="checkbox"/>
13. Day Tank	<input type="checkbox"/>
14. Generator	<input type="checkbox"/>
15. Voltage Regulator	<input type="checkbox"/>
16. Circuit Breaker	<input type="checkbox"/>
17. Emergency Stop Push Button	<input type="checkbox"/>
18. Manual Fuel Shutdown	<input type="checkbox"/>
19. Engine Protection Systems (LO, WT, OS, OC)	<input type="checkbox"/>
20. Engine Lubrication Type	<input type="checkbox"/>
21. Oil Sump Screen	<input type="checkbox"/>
22. Oil Filter Change Procedure and Interval	<input type="checkbox"/>
23. Oil Change Procedure and Interval	<input type="checkbox"/>
24. S.O.S	<input type="checkbox"/>
25. Starting System	<input type="checkbox"/>
26. Jacket Water Heaters	<input type="checkbox"/>
27. Automatic Transfer Switch	<input type="checkbox"/>
28. Troubleshooting	<input type="checkbox"/>
29. Replacement Parts Ordering	<input type="checkbox"/>
30. SCR / DPF / CEM	<input type="checkbox"/>
31. DEF (Urea) System	<input type="checkbox"/>
32. Miscellaneous Items	<input type="checkbox"/>
33.	<input type="checkbox"/>

Technician

Date

CARTER POWER SYSTEMS

Section Two PACKAGE TECHNICAL DATA

Caterpillar Model C32 1250 KW Package Brochure

Engine Specific Performance Data

Generator Specific Technical Data

Voltage Regulator

Governor

Control Panel

This page intentionally left blank

Cat® D1250 GC

Diesel Generator Sets



Image shown might not reflect actual configuration.

Engine	C32
Bore – mm (in)	145 (5.7)
Stroke – mm (in)	162 (6.4)
Displacement – L (in ³)	32.1 (1959)
Compression Ratio	14.0:1
Aspiration	TA
Fuel System	EUI
Governor Type	ADEM™ A4

Model	Standby 60 Hz ekW (kVA)	Emissions Performance
D1250 GC	1250 (1562)	U.S EPA Emergency Stationary Use only (Tier 2)

Standard Features

Cat® Diesel Engine

- Meets U.S. EPA Emergency Stationary Use only (Tier 2) emission standards
- Reliable performance proven in thousands of applications worldwide

Generator Set Package

- Accepts 100% block load in one step and meets NFPA 110 loading requirements
- Conforms to ISO 8528-5 G3 load acceptance requirements
- Reliability is verified through prototype testing, which includes torsional vibration, fuel consumption, oil consumption, transient performance, and endurance testing

Alternators

- Superior motor starting capability minimizes the need for oversizing the generator
- Designed to match the performance and output characteristics of Cat diesel engines

Cooling System

- Cooling systems available to operate in ambient temperatures
- Tested to ensure proper generator set cooling

GCCP Control Panels

- User-friendly set-up and button layout for ease of use
- Multiple parameters are monitored & displayed simultaneously for full visibility
- The module can be configured to suit a wide range of applications for user flexibility

Warranty and Extended Service Coverage (ESC)

- 24 months/1000-hour warranty for standby ratings
- 5 yrs Gold Complimentary Extended Service Coverage

Worldwide Product Support

- Cat dealers have over 1,800 dealer branch stores operating in 200 countries
- Your local Cat dealer provides extensive post-sale support, including maintenance and repair agreements

Financing

- Caterpillar offers an array of financial products to help you succeed through financial service excellence
- Options include loans, finance lease, operating lease, working capital, and revolving line of credit
- Contact your local Cat dealer for availability in your region

Standard and Optional Equipment

Engine

Air Cleaner

- Single element
- Dual element

Starting

- Standard batteries
- Oversized batteries
- Dual Electric Starters
- Jacket water heater

Engine Attachments

- 6" Exhaust Flexible Fittings
- 6" Exhaust Flange Kits
- Radiator Duct Flange

Alternator

Output voltage

- 480V
- 600V

Temperature Rise (over 40°C ambient)

- 125°C
- 105°C

Winding type

- Random wound

Excitation

- Internal excitation (IE)
- Permanent magnet (PM)

Attachments

- Anti-condensation heater

Power Termination

Type

- Circuit breaker (Primary)
- 1200A 1600A 2000A
- Circuit breaker (Auxiliary)
- 250A 400A

- 3-pole

- Manually operated

Trip Unit

- LSI LSIG LSIG-P

Factory Enclosure

- Sound attenuated
- Weatherproof

Attachments

- DC lighting package

Fuel Tank

- Intergrated 2100 gal (7950 L)
- Sub base 3000 gal (11356 L)
- Sub base 4200 gal (15876 L)

Control System

Controller

- GCCP 1.2

Attachments

- Remote annunciator module
- Expansion I/O module
- 100A Load Center
- 20A GFCI AC Receptacle
- Ground Fault Indication
- Audible Alarm

Charging

- Battery charger – 10A (Installed)
- Battery charger – 20A
(Shipped loose)

Cat Connect

Connectivity

- Ethernet
- Cellular

Extended Service Options

Terms

- 3 year
- 4 year
- 5 year

Coverage

- Silver
- Gold

Certifications

- UL 2200 Listed
- cUL CSA 22.2 No. 100-14
- IBC seismic certification

Provided via 3rd party. See fuel tank specs in section 5.

Note: Some options may not be available on all models. Certifications may not be available with all model configurations. Consult factory for availability.

D1250 GC Diesel Generator Sets

Electric Power



Package Performance – D1250 GC

Performance	Standby	
Frequency	60 Hz	
Gen set power rating with fan	1250 ekW	
Gen set power rating with fan @ 0.8 power factor	1562.5 kVA	
Fueling strategy	EPA ESE (Tier 2)	
Performance number	EM2324	
Fuel Consumption		
100% load with fan – L/hr (gal/hr)	330.9	(87.4)
75% load with fan – L/hr (gal/hr)	268.9	(71.0)
50% load with fan – L/hr (gal/hr)	181.1	(47.8)
25% load with fan – L/hr (gal/hr)	102.1	(27.0)
Cooling System		
Radiator air flow restriction (system) – kPa (in. water)	0.12	(0.48)
Radiator air flow – m ³ /min (cfm)	1109	(39164)
Engine coolant capacity – L (gal)	55	(14.5)
Radiator coolant capacity – L (gal)	61	(16.1)
Total coolant capacity – L (gal)	116	(30.6)
Inlet Air		
Combustion air inlet flow rate – m ³ /min (cfm)	118.0	(4168.3)
Exhaust System		
Exhaust stack gas temperature – °C (°F)	430.3	(806.6)
Exhaust gas flow rate – m ³ /min (cfm)	283.4	(10005.8)
Exhaust system backpressure (maximum allowable) – kPa (in. water)	6.7	(27.0)
Heat Rejection		
Heat rejection to jacket water – kW (Btu/min)	403	(22908)
Heat rejection to exhaust (total) – kW (Btu/min)	1097	(62361)
Heat rejection to aftercooler – kW (Btu/min)	452	(25715)
Heat rejection to atmosphere from engine – kW (Btu/min)	222	(12620)
Heat rejection from alternator – kW (Btu/min)	58.9	(3350)
Emissions* (Nominal)		
NOx mg/Nm ³ (g/hp-h)	2416.9	(5.13)
CO mg/Nm ³ (g/hp-h)	53.0	(0.11)
HC mg/Nm ³ (g/hp-h)	21.6	(0.05)
PM mg/Nm ³ (g/hp-h)	5.1	(0.01)
Emissions* (Potential Site Variation)		
NOx mg/Nm ³ (g/hp-h)	2924.5	(6.20)
CO mg/Nm ³ (g/hp-h)	99.1	(0.21)
HC mg/Nm ³ (g/hp-h)	40.8	(0.10)
PM mg/Nm ³ (g/hp-h)	10.0	(0.02)

*mg/Nm³ levels are corrected to 5% O₂. Contact your local Cat dealer for further information.

D1250 GC Diesel Generator Sets Electric Power



Weights and Dimensions

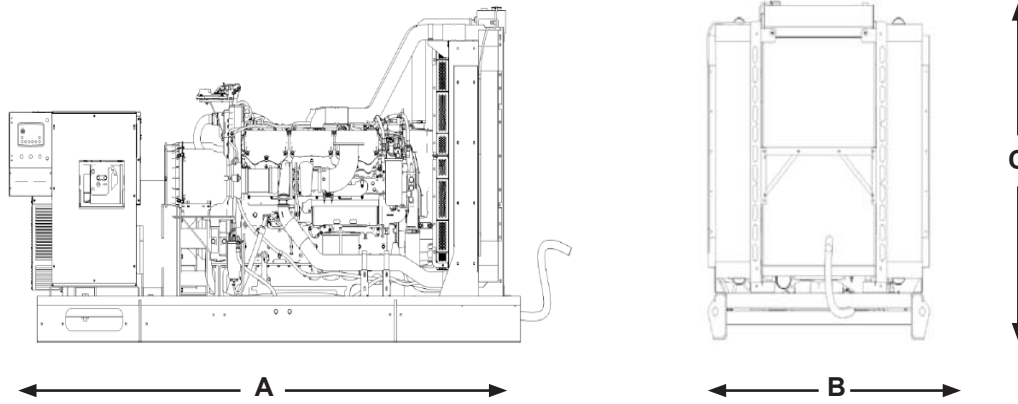

Model	Dim "A" mm (in)	Dim "B" mm (in)	Dim "C" mm (in)	Wet Weight kg (lb)
D1250 GC	4175 (164.3)	2090.5 (82.3)	2268 (89.3)	7156 (15776)

Note: For reference only. Do not use for installation design. Contact your local Cat dealer for precise weights and dimensions.

Ratings and Definitions

Standby

Output available with varying load for the duration of the interruption of the normal source power. Average power output is 70% of the standby power rating. Typical operation is 200 hours per year, with maximum expected usage of 500 hours per year.

Applicable Codes and Standards

CSA C22.2 No. 100-14, UL 142, UL 489, UL 869A, UL 2200, IBC 2018, ISO 3046, ISO 8528 and facilitates compliance to NFPA37, NFPA70, NFPA99 and NFPA110 codes.

Note: Codes may not be available in all model configurations. Please consult your local Cat dealer for availability.

Fuel Rates

Fuel rates are based on fuel oil of 35° API [16°C (60°F)] gravity having an LHV of 42,780 kJ/kg (18,390 Btu/lb) when used at 29°C (85°F) and weighing 838.9 g/liter (7.001 lbs/U.S. gal.).

www.cat.com/electricpower

©2022 Caterpillar
All rights reserved.

Materials and specifications are subject to change without notice.

The International System of Units (SI) is used in this publication. CAT, CATERPILLAR, LET'S DO THE WORK, their respective logos, "Caterpillar Corporate Yellow", the "Power Edge" and Cat "Modern Hex" trade dress as well as corporate and product identity used herein, are trademarks of Caterpillar and may not be used without permission.

LET'S DO THE WORK.™

Performance Number: EM2324

Change Level: 10

SALES MODEL:	C32	COMBUSTION:	DIRECT INJECTION
BRAND:	CAT	ENGINE SPEED (RPM):	1,800
MACHINE SALES MODEL:		HERTZ:	60
ENGINE POWER (BHP):	1,829	FAN POWER (HP):	60.3
GEN POWER WITH FAN (EKW):	1,250.0	ASPIRATION:	TA
COMPRESSION RATIO:	14	AFTERCOOLER TYPE:	ATAAC
RATING LEVEL:	STANDBY	AFTERCOOLER CIRCUIT TYPE:	JW+OC, AC
PUMP QUANTITY:	1	INLET MANIFOLD AIR TEMP (F):	120
FUEL TYPE:	DIESEL	JACKET WATER TEMP (F):	210.2
MANIFOLD TYPE:	DRY	TURBO CONFIGURATION:	PARALLEL
GOVERNOR TYPE:	ADEM4	TURBO QUANTITY:	2
ELECTRONICS TYPE:	ADEM4	TURBOCHARGER MODEL:	GT5733-1.6A/R
IGNITION TYPE:	CI	CERTIFICATION YEAR:	2017
INJECTOR TYPE:	EUI	PISTON SPD @ RATED ENG SPD (FT/MIN):	1,913.4
REF EXH STACK DIAMETER (IN):	6		
MAX OPERATING ALTITUDE (FT):	5,400		

INDUSTRY	SUBINDUSTRY	APPLICATION
ELECTRIC POWER	STANDARD	PACKAGED GENSET

General Performance Data

THIS STANDBY RATING IS FOR A STANDBY ONLY ENGINE ARRANGEMENT. RERATING THE ENGINE TO A PRIME OR CONTINUOUS RATING IS NOT PERMITTED.

GENSET POWER WITH FAN	PERCENT LOAD	ENGINE POWER	BRAKE MEAN EFF PRES (BMEP)	BRAKE SPEC FUEL CONSUMPTN (BSFC)	ISO BRAKE SPEC FUEL CONSUMPTN (BSFC)	VOL FUEL CONSUMPTN (VFC)	ISO VOL FUEL CONSUMPTN (VFC)
EKW	%	BHP	PSI	LB/BHP-HR	LB/BHP-HR	GAL/HR	GAL/HR
1,250.0	100	1,821	409	0.336	0.331	86.3	85.0
1,125.0	90	1,642	369	0.343	0.338	79.3	78.1
1,000.0	80	1,465	329	0.354	0.349	73.2	72.1
937.5	75	1,377	309	0.361	0.356	70.1	69.1
875.0	70	1,289	290	0.357	0.352	65.0	64.0
750.0	60	1,115	250	0.350	0.345	55.0	54.2
625.0	50	942	212	0.356	0.351	47.2	46.5
500.0	40	770	173	0.365	0.360	39.7	39.1
375.0	30	598	134	0.367	0.362	30.9	30.5
312.5	25	511	115	0.369	0.364	26.6	26.2
250.0	20	424	95	0.375	0.370	22.4	22.1
125.0	10	244	55	0.402	0.397	13.9	13.7

GENSET POWER WITH FAN	PERCENT LOAD	ENGINE POWER	INLET MFLD PRES	INLET MFLD TEMP	EXH MFLD TEMP	ENGINE OUTLET TEMP	COMPRESSOR OUTLET PRES	COMPRESSOR OUTLET TEMP
EKW	%	BHP	IN-HG	DEG F	DEG F	DEG F	IN-HG	DEG F
1,250.0	100	1,821	94.3	117.9	1,177.6	806.6	99	487.0
1,125.0	90	1,642	89.7	113.2	1,139.6	786.2	94	466.3
1,000.0	80	1,465	84.9	111.1	1,125.0	770.7	90	450.3
937.5	75	1,377	83.4	113.3	1,112.5	764.3	88	441.2
875.0	70	1,289	77.5	111.6	1,076.1	751.3	82	418.8
750.0	60	1,115	62.8	104.2	1,010.2	733.5	67	368.5
625.0	50	942	52.2	99.0	967.0	720.3	56	332.0
500.0	40	770	41.7	94.0	952.9	706.8	45	294.3
375.0	30	598	27.5	90.1	869.6	687.0	30	235.3
312.5	25	511	21.0	89.1	832.1	670.5	23	206.5
250.0	20	424	15.2	89.5	806.0	642.6	17	180.7
125.0	10	244	5.0	91.2	642.7	547.9	6	132.9

General Performance Data (Continued)

GENSET POWER WITH FAN	PERCENT LOAD	ENGINE POWER	WET INLET AIR VOL FLOW RATE	ENGINE OUTLET WET EXH GAS VOL FLOW RATE	WET INLET AIR MASS FLOW RATE	WET EXH GAS MASS FLOW RATE	WET EXH VOL FLOW RATE (32 DEG F AND 29.98 IN HG)
EKW	%	BHP	CFM	CFM	LB/HR	LB/HR	FT3/MIN
1,250.0	100	1,821	4,168.3	10,005.8	17,027.4	17,639.4	3,885.1

PERFORMANCE DATA[EM2324]

July 11, 2022

1,125.0	90	1,642	4,026.2	9,500.0	16,497.7	17,060.1	3,748.9
1,000.0	80	1,465	3,901.7	9,086.5	16,028.5	16,547.5	3,631.0
937.5	75	1,377	3,822.3	8,855.0	15,727.9	16,225.2	3,557.0
875.0	70	1,289	3,617.6	8,314.2	14,951.9	15,412.1	3,375.6
750.0	60	1,115	3,114.3	7,116.6	12,999.2	13,389.1	2,932.5
625.0	50	942	2,754.6	6,254.1	11,575.6	11,909.7	2,606.0
500.0	40	770	2,386.6	5,377.5	10,085.0	10,366.5	2,266.6
375.0	30	598	1,867.9	4,168.1	7,949.2	8,168.3	1,787.2
312.5	25	511	1,629.3	3,589.3	6,955.0	7,143.7	1,561.5
250.0	20	424	1,418.1	3,048.3	6,064.8	6,223.7	1,359.7
125.0	10	244	1,057.1	2,065.4	4,535.6	4,633.9	1,007.9

Heat Rejection Data

GENSET POWER WITH FAN	PERCENT LOAD	ENGINE POWER	REJECTION TO JACKET WATER	REJECTION TO ATMOSPHERE	REJECTION TO EXH	FROM OIL COOLER	FROM AFTERCOOLER	WORK ENERGY	LOW HEAT VALUE ENERGY	HIGH HEAT VALUE ENERGY
EKW	%	BHP	BTU/MIN	BTU/MIN	BTU/MIN	BTU/MIN	BTU/MIN	BTU/MIN	BTU/MIN	BTU/MIN
1,250.0	100	1,821	22,908	12,620	62,361	10,016	25,715	77,230	188,054	200,325
1,125.0	90	1,642	22,092	11,784	59,539	9,352	24,453	69,619	175,588	187,045
1,000.0	80	1,465	20,830	10,798	55,674	8,570	22,354	62,110	160,898	171,397
937.5	75	1,377	20,024	10,247	53,309	8,132	20,980	58,386	152,684	162,647
875.0	70	1,289	18,945	9,616	50,167	7,632	19,168	54,664	143,288	152,638
750.0	60	1,115	16,636	8,289	43,954	6,579	15,186	47,276	123,514	131,573
625.0	50	942	14,368	6,933	37,808	5,502	11,074	39,933	103,307	110,048
500.0	40	770	12,970	5,717	31,758	4,538	7,552	32,669	85,193	90,752
375.0	30	598	11,780	4,539	25,709	3,603	4,519	25,372	67,640	72,054
312.5	25	511	11,137	3,948	22,667	3,133	3,166	21,689	58,828	62,666
250.0	20	424	10,373	3,345	19,417	2,655	2,018	17,965	49,845	53,097
125.0	10	244	8,452	2,099	11,801	1,666	605	10,367	31,274	33,315

Emissions Data

DIESEL

RATED SPEED NOMINAL DATA: 1800 RPM

GENSET POWER WITH FAN	EKW	1,250.0	937.5	625.0	312.5	125.0
PERCENT LOAD	%	100	75	50	25	10
ENGINE POWER	BHP	1,821	1,377	942	511	244
TOTAL NOX (AS NO2)	G/HR	9,406	5,063	3,280	1,901	1,371
TOTAL CO	G/HR	172	192	146	403	510
TOTAL HC	G/HR	93	96	80	71	86
TOTAL CO2	KG/HR	874	707	480	273	145
PART MATTER	G/HR	24.0	31.9	23.0	55.3	31.8
TOTAL NOX (AS NO2) (CORR 5% O2)	MG/NM3	2,662.7	1,758.6	1,677.1	1,726.0	2,438.7
TOTAL CO (CORR 5% O2)	MG/NM3	44.5	61.4	70.9	332.9	844.3
TOTAL HC (CORR 5% O2)	MG/NM3	20.8	26.6	32.6	51.9	127.5
PART MATTER (CORR 5% O2)	MG/NM3	5.3	8.9	9.8	42.3	39.7
TOTAL NOX (AS NO2) (CORR 5% O2)	PPM	1,297	857	817	841	1,188
TOTAL CO (CORR 5% O2)	PPM	36	49	57	266	675
TOTAL HC (CORR 5% O2)	PPM	39	50	61	97	238
TOTAL NOX (AS NO2)	G/HP-HR	5.20	3.70	3.50	3.72	5.61
TOTAL CO	G/HP-HR	0.09	0.14	0.16	0.79	2.09
TOTAL HC	G/HP-HR	0.05	0.07	0.09	0.14	0.35
PART MATTER	G/HP-HR	0.01	0.02	0.02	0.11	0.13
TOTAL NOX (AS NO2)	LB/HR	20.74	11.16	7.23	4.19	3.02
TOTAL CO	LB/HR	0.38	0.42	0.32	0.89	1.12
TOTAL HC	LB/HR	0.21	0.21	0.18	0.16	0.19
TOTAL CO2	LB/HR	1,927	1,558	1,057	601	319
PART MATTER	LB/HR	0.05	0.07	0.05	0.12	0.07
OXYGEN IN EXH	%	10.3	11.7	12.6	12.9	14.6
DRY SMOKE OPACITY	%	0.5	0.6	0.6	1.5	0.9

PERFORMANCE DATA[EM2324]

July 11, 2022

BOSCH SMOKE NUMBER	0.17	0.32	0.29	1.02	0.60
--------------------	------	------	------	------	------

RATED SPEED POTENTIAL SITE VARIATION: 1800 RPM

GENSET POWER WITH FAN	EKW	1,250.0	937.5	625.0	312.5	125.0
PERCENT LOAD	%	100	75	50	25	10
ENGINE POWER	BHP	1,821	1,377	942	511	244
TOTAL NOX (AS NO2)	G/HR	11,381	6,127	3,968	2,300	1,659
TOTAL CO	G/HR	321	359	272	754	953
TOTAL HC	G/HR	176	182	151	134	163
PART MATTER	G/HR	46.8	62.2	44.9	107.8	62.0
TOTAL NOX (AS NO2) (CORR 5% O2)	MG/NM3	3,221.8	2,127.9	2,029.3	2,088.5	2,950.8
TOTAL CO (CORR 5% O2)	MG/NM3	83.2	114.7	132.6	622.6	1,578.9
TOTAL HC (CORR 5% O2)	MG/NM3	39.4	50.3	61.7	98.2	241.0
PART MATTER (CORR 5% O2)	MG/NM3	10.4	17.3	19.1	82.5	77.4
TOTAL NOX (AS NO2) (CORR 5% O2)	PPM	1,569	1,036	988	1,017	1,437
TOTAL CO (CORR 5% O2)	PPM	67	92	106	498	1,263
TOTAL HC (CORR 5% O2)	PPM	73	94	115	183	450
TOTAL NOX (AS NO2)	G/HP-HR	6.29	4.48	4.23	4.51	6.79
TOTAL CO	G/HP-HR	0.18	0.26	0.29	1.48	3.90
TOTAL HC	G/HP-HR	0.10	0.13	0.16	0.26	0.67
PART MATTER	G/HP-HR	0.03	0.05	0.05	0.21	0.25
TOTAL NOX (AS NO2)	LB/HR	25.09	13.51	8.75	5.07	3.66
TOTAL CO	LB/HR	0.71	0.79	0.60	1.66	2.10
TOTAL HC	LB/HR	0.39	0.40	0.33	0.29	0.36
PART MATTER	LB/HR	0.10	0.14	0.10	0.24	0.14

Regulatory Information

EPA TIER 2		2006 - 2010			
GASEOUS EMISSIONS DATA MEASUREMENTS PROVIDED TO THE EPA ARE CONSISTENT WITH THOSE DESCRIBED IN EPA 40 CFR PART 89 SUBPART D AND ISO 8178 FOR MEASURING HC, CO, PM, AND NOX. THE "MAX LIMITS" SHOWN BELOW ARE WEIGHTED CYCLE AVERAGES AND ARE IN COMPLIANCE WITH THE NON-ROAD REGULATIONS.					
Locality	Agency	Regulation	Tier/Stage	Max Limits - G/BKW - HR	
U.S. (INCL CALIF)	EPA	NON-ROAD	TIER 2	CO: 3.5 NOx + HC: 6.4 PM: 0.20	

EPA EMERGENCY STATIONARY		2011 - ----			
GASEOUS EMISSIONS DATA MEASUREMENTS PROVIDED TO THE EPA ARE CONSISTENT WITH THOSE DESCRIBED IN EPA 40 CFR PART 60 SUBPART IIII AND ISO 8178 FOR MEASURING HC, CO, PM, AND NOX. THE "MAX LIMITS" SHOWN BELOW ARE WEIGHTED CYCLE AVERAGES AND ARE IN COMPLIANCE WITH THE EMERGENCY STATIONARY REGULATIONS.					
Locality	Agency	Regulation	Tier/Stage	Max Limits - G/BKW - HR	
U.S. (INCL CALIF)	EPA	STATIONARY	EMERGENCY STATIONARY	CO: 3.5 NOx + HC: 6.4 PM: 0.20	

Altitude Derate Data

THE FOLLOWING ALTITUDE DERATE TABLE INCLUDES SOFTWARE DERATES THAT PROTECT THE ENGINE AT HIGH AMBIENT TEMPERATURES AND ALTITUDES. ACTUAL OBSERVED POWER CAN CHANGE DUE TO AMBIENT CONDITIONS AND FUEL USED. PLEASE REVIEW THE SUPPLEMENTARY FILE LINKED TO THIS PERFORMANCE FILE FOR ADDITIONAL INFORMATION.

STANDARD

ALTITUDE CORRECTED POWER CAPABILITY (BHP)

AMBIENT OPERATING TEMP (F)	30	40	50	60	70	80	90	100	110	120	130	140	NORMAL
ALTITUDE (FT)													
0	1,829	1,829	1,829	1,829	1,829	1,829	1,829	1,829	1,829	1,829	1,770	1,622	1,829
1,000	1,829	1,829	1,829	1,829	1,829	1,829	1,829	1,829	1,829	1,829	1,704	1,570	1,829
2,000	1,829	1,829	1,829	1,829	1,829	1,829	1,829	1,829	1,829	1,721	1,581	1,478	1,829
3,000	1,829	1,829	1,829	1,829	1,829	1,829	1,829	1,829	1,759	1,586	1,483	1,397	1,829
4,000	1,829	1,829	1,829	1,829	1,829	1,829	1,829	1,809	1,633	1,491	1,395	1,324	1,829
5,000	1,829	1,829	1,829	1,829	1,829	1,829	1,771	1,671	1,513	1,403	1,318	1,266	1,829
6,000	1,829	1,829	1,786	1,755	1,708	1,673	1,630	1,551	1,436	1,356	1,284	1,236	1,765

PERFORMANCE DATA[EM2324]

July 11, 2022

7,000	1,754	1,692	1,641	1,604	1,574	1,543	1,516	1,465	1,390	1,327	1,270	1,223	1,627
8,000	1,614	1,556	1,509	1,488	1,481	1,472	1,454	1,405	1,358	1,303	1,260	1,223	1,509
9,000	1,459	1,412	1,386	1,386	1,393	1,395	1,386	1,359	1,314	1,273	1,233	1,184	1,394
10,000	1,355	1,331	1,311	1,317	1,338	1,347	1,338	1,312	1,279	1,242	1,196	1,144	1,325
11,000	1,283	1,268	1,254	1,260	1,289	1,302	1,295	1,276	1,247	1,207	1,155	1,105	1,269
12,000	1,239	1,227	1,212	1,204	1,252	1,270	1,264	1,246	1,212	1,167	1,118	989	1,232
13,000	1,196	1,183	1,169	1,151	1,209	1,241	1,232	1,212	1,175	1,131	1,061	934	1,193
14,000	1,159	1,148	1,134	1,105	1,157	1,202	1,190	1,174	1,141	1,096	971	930	1,161
15,000	1,118	1,105	1,093	1,067	1,100	1,160	1,153	1,139	1,078	1,019	946	936	1,125

Cross Reference

Test Spec	Setting	Engine Arrangement	Engineering Model	Engineering Model Version	Start Effective Serial Number	End Effective Serial Number
4486191	GG3605	4969941	PG289	-	JP500001	
4486191	GG3605	5612773	PG289	DK	JP500001	
4486191	GG3605	6034726	PG456	-	JP500001	

Supplementary Data

Type	Classification	Performance Number
ALTITUDE DATA	WITH NATURAL DERATE	EM2581

Performance Parameter Reference

Parameters Reference:DM9600-14 PERFORMANCE DEFINITIONS

PERFORMANCE DEFINITIONS DM9600

APPLICATION:

Engine performance tolerance values below are representative of a typical production engine tested in a calibrated dynamometer test cell at SAE J1995 standard reference conditions. Caterpillar maintains ISO9001:2000 certified quality management systems for engine test Facilities to assure accurate calibration of test equipment. Engine test data is corrected in accordance with SAE J1995. Additional reference material SAE J1228, J1349, ISO 8665, 3046-1:2002E, 3046-3:1989, 1585, 2534, 2288, and 9249 may apply in part or are similar to SAE J1995. Special engine rating request (SERR) test data shall be noted.

PERFORMANCE PARAMETER TOLERANCE FACTORS:

Power +/- 3%

Torque +/- 3%

Exhaust stack temperature +/- 8%

Inlet airflow +/- 5%

Intake manifold pressure-gage +/- 10%

Exhaust flow +/- 6%

Specific fuel consumption +/- 3%

Fuel rate +/- 5%

Specific DEF consumption +/- 3%

DEF rate +/- 5%

Heat rejection +/- 5%

Heat rejection exhaust only +/- 10%

Heat rejection CEM only +/- 10%

Heat Rejection values based on using treated water.

Torque is included for truck and industrial applications, do not use for Gen Set or steady state applications.

On C7 - C18 engines, at speeds of 1100 RPM and under these values are provided for reference only, and may not meet the tolerance listed.

On 3500 and C175 engines, at speeds below Peak Torque these values are provided for reference only, and may not meet the tolerance listed.

These values do not apply to C280/3600. For these models, see the tolerances listed below.

C280/3600 HEAT REJECTION TOLERANCE FACTORS:

Heat rejection +/- 10%

Heat rejection to Atmosphere +/- 50%

Heat rejection to Lube Oil +/- 20%

Heat rejection to Aftercooler +/- 5%

TEST CELL TRANSDUCER TOLERANCE FACTORS:

PERFORMANCE DATA[EM2324]

July 11, 2022

Torque +/- 0.5%

Speed +/- 0.2%

Fuel flow +/- 1.0%

Temperature +/- 2.0 C degrees

Intake manifold pressure +/- 0.1 kPa

OBSERVED ENGINE PERFORMANCE IS CORRECTED TO SAE J1995 REFERENCE

AIR AND FUEL CONDITIONS.

REFERENCE ATMOSPHERIC INLET AIR

FOR 3500 ENGINES AND SMALLER

SAE J1228 AUG2002 for marine engines, and J1995 JAN2014 for other engines, reference atmospheric pressure is 100 KPA (29.61 in hg), and standard temperature is 25deg C (77 deg F) at 30% relative humidity at the stated aftercooler water temp, or inlet manifold temp.

FOR 3600 ENGINES

Engine rating obtained and presented in accordance with ISO 3046/1 and SAE J1995 JANJAN2014 reference atmospheric pressure is 100 KPA (29.61 in hg), and standard temperature is 25deg C (77 deg F) at 30% relative humidity and 150M altitude at the stated aftercooler water temperature.

MEASUREMENT LOCATION FOR INLET AIR TEMPERATURE

Location for air temperature measurement air cleaner inlet at stabilized operating conditions.

REFERENCE EXHAUST STACK DIAMETER

The Reference Exhaust Stack Diameter published with this dataset is only used for the calculation of Smoke Opacity values displayed in this dataset. This value does not necessarily represent the actual stack diameter of the engine due to the variety of exhaust stack adapter options available. Consult the price list, engine order or general dimension drawings for the actual stack diameter size ordered or options available.

REFERENCE FUEL

DIESEL

Reference fuel is #2 distillate diesel with a 35API gravity;

A lower heating value is 42,780 KJ/KG (18,390 BTU/LB) when used at 15 deg C (59 deg F), where the density is

850 G/Liter (7.0936 Lbs/Gal).

GAS

Reference natural gas fuel has a lower heating value of 33.74 KJ/L (905 BTU/CU Ft). Low BTU ratings are based on 18.64 KJ/L (500 BTU/CU FT) lower heating value gas. Propane ratings are based on 87.56 KJ/L (2350 BTU/CU Ft) lower heating value gas.

ENGINE POWER (NET) IS THE CORRECTED FLYWHEEL POWER (GROSS) LESS EXTERNAL AUXILIARY LOAD

Engine corrected gross output includes the power required to drive standard equipment; lube oil, scavenge lube oil, fuel transfer, common rail fuel, separate circuit aftercooler and jacket water pumps. Engine net power available for the external (flywheel) load is calculated by subtracting the sum of auxiliary load from the corrected gross flywheel out put power. Typical auxiliary loads are radiator cooling fans, hydraulic pumps, air compressors and battery charging alternators. For Tier 4 ratings additional Parasitic losses would also include Intake, and Exhaust Restrictions.

ALTITUDE CAPABILITY

Altitude capability is the maximum altitude above sea level at standard temperature and standard pressure at which the engine could develop full rated output power on the current performance data set.

Standard temperature values versus altitude could be seen on TM2001.

When viewing the altitude capability chart the ambient temperature is the inlet air temp at the compressor inlet.

Engines with ADEM MEUI and HEUI fuel systems operating at conditions above the defined altitude capability derate for atmospheric pressure and temperature conditions outside the values defined, see TM2001.

Mechanical governor controlled unit injector engines require a setting change for operation at conditions above the altitude defined on the engine performance sheet. See your Caterpillar technical representative for non standard ratings.

REGULATIONS AND PRODUCT COMPLIANCE

TMI Emissions information is presented at 'nominal' and 'Potential Site Variation' values for standard ratings. No tolerances are applied to the emissions data. These values are subject to change at any time. The controlling federal and local emission requirements need to be verified by your Caterpillar technical representative.

Customer's may have special emission site requirements that need to be verified by the Caterpillar Product Group engineer.

EMISSION CYCLE LIMITS:

Cycle emissions Max Limits apply to cycle-weighted averages only. Emissions at individual load points may exceed the cycle-weighted limit.

WET & DRY EXHAUST/EMISSIONS DESCRIPTION:

Wet - Total exhaust flow or concentration of total exhaust flow

Dry - Total exhaust flow minus water vapor or concentration of exhaust flow with water vapor excluded

PERFORMANCE DATA[EM2324]

July 11, 2022

EMISSIONS DEFINITIONS:

Emissions : DM1176

EMISSION CYCLE DEFINITIONS

1. For constant-speed marine engines for ship main propulsion, including diesel-electric drive, test cycle E2 shall be applied, for controllable-pitch propeller sets test cycle E2 shall be applied.
2. For propeller-law-operated main and propeller-law-operated auxiliary engines the test cycle E3 shall be applied.
3. For constant-speed auxiliary engines test cycle D2 shall be applied.
4. For variable-speed, variable-load auxiliary engines, not included above, test cycle C1 shall be applied.

HEAT REJECTION DEFINITIONS:

Diesel Circuit Type and HHV Balance : DM9500

HIGH DISPLACEMENT (HD) DEFINITIONS:

3500: EM1500

RATING DEFINITIONS:

Agriculture : TM6008

Fire Pump : TM6009

Generator Set : TM6035

Generator (Gas) : TM6041

Industrial Diesel : TM6010

Industrial (Gas) : TM6040

Irrigation : TM5749

Locomotive : TM6037

Marine Auxiliary : TM6036

Marine Prop (Except 3600) : TM5747

Marine Prop (3600 only) : TM5748

MSHA : TM6042

Oil Field (Petroleum) : TM6011

Off-Highway Truck : TM6039

On-Highway Truck : TM6038

SOUND DEFINITIONS:

Sound Power : DM8702

Sound Pressure : TM7080

Date Released : 10/27/21

Engine: C32	Generator Frame: E3875L4	Selected Model	Line Voltage: 480
Fuel: Diesel	Generator Arrangement: 6145658	Genset Rating (kW): 1250.0	Phase Voltage: 277
Frequency: 60	Excitation Type: Permanent Magnet	Genset Rating (kVA): 1563.0	Rated Current: 1880.0
Duty: STANDBY	Connection: PARALLEL STAR	Pwr. Factor: 0.8	Status: Current
		Application: EPG	Version: 20224 / 20224 / 20224 / 677642

Generator Specification		Generator Efficiency	
Frame: E3875L4 Type: SR500	No. of Bearings: 1	Per Unit Load	kW
Winding Type: RANDOM WOUND	Flywheel: 18.0	0.25	312.5
Connection: PARALLEL STAR	Housing: 0	0.5	625.0
Phases: 3	No. of Leads: 12	0.75	937.5
Poles: 4	Generator Pitch: 0.6667	1.0	1250.0
Sync Speed: 1800			Efficiency %
			92.5
			95.2
			96.5
			96.4

Reactances	Per Unit	Ohms
SUBTRANSIENT - DIRECT AXIS X _d	0.0726	0.0107
SUBTRANSIENT - QUADRATURE AXIS X _q	0.1655	0.0244
TRANSIENT - SATURATED X _d	0.1539	0.0227
SYNCHRONOUS - DIRECT AXIS X _d	3.9164	0.5775
SYNCHRONOUS - QUADRATURE AXIS X _q	1.5042	0.2218
NEGATIVE SEQUENCE X ₂	0.1180	0.0174
ZERO SEQUENCE X ₀	0.0407	0.0060

Time Constants	Seconds
OPEN CIRCUIT TRANSIENT - DIRECT AXIS T _{do}	8.9000
SHORT CIRCUIT TRANSIENT - DIRECT AXIS T _d	0.2710
OPEN CIRCUIT SUBTRANSIENT - DIRECT AXIS T _{do}	0.0384
SHORT CIRCUIT SUBTRANSIENT - DIRECT AXIS T _d	0.0180
ARMATURE SHORT CIRCUIT T _a	0.0260

Short Circuit Ratio: 0.3793	Stator Resistance = 0.006 Ohms	Field Resistance = 2.8 Ohms
-----------------------------	--------------------------------	-----------------------------

Voltage Regulation		Generator Excitation	
Voltage level adjustment: +/-	5.0%	No Load	Full Load, (rated) pf Series
Voltage regulation, steady state: +/-	0.5%	Excitation voltage:	12.76 Volts
Voltage regulation with 3% speed change: +/-	0.5%	Excitation current	1.2 Amps
Waveform deviation line - line, no load: less than	2.0%		41.63 Volts
Telephone influence factor: less than	40		3.92 Amps

Engine: C32	Generator Frame: E3875L4	Selected Model	Line Voltage: 480
Fuel: Diesel	Generator Arrangement: 6145658	Genset Rating (kW): 1250.0	Phase Voltage: 277
Frequency: 60	Excitation Type: Permanent Magnet	Genset Rating (kVA): 1563.0	Rated Current: 1880.0
Duty: STANDBY	Connection: PARALLEL STAR	Pwr. Factor: 0.8	Status: Current
		Application: EPG	Version: 20224 / 20224 / 20224 / 677642

Generator Mechanical Information	
Center of Gravity	
Dimension X	750.0 mm / 29.5 IN.
Dimension Y	400.0 mm / 15.7 IN.
Dimension Z	0.0 mm / 0.0 IN.
<ul style="list-style-type: none"> "X" is measured from driven end of generator and parallel to rotor. Towards engine fan is positive. See General Information for details "Y" is measured vertically from rotor center line. Up is positive. "Z" is measured to left and right of rotor center line. To the right is positive. 	
Generator WT = 2700 kg * Rotor WT = 1026 kg * Stator WT = 1424 kg 5,952 LB 2,262 LB 3,139 LB	
Rotor Balance = 0.016 mm deflection PTP	
Overspeed Capacity = 125% of synchronous speed	

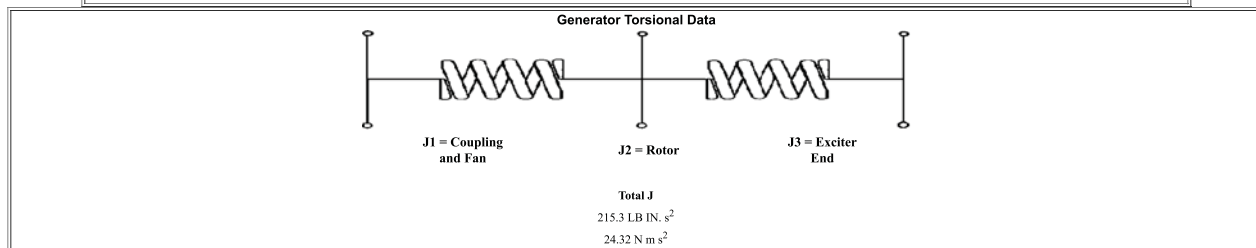

Engine: C32	Generator Frame: E3875L4	Selected Model	Line Voltage: 480
Fuel: Diesel	Generator Arrangement: 6145658	Genset Rating (kW): 1250.0	Phase Voltage: 277
Frequency: 60	Excitation Type: Permanent Magnet	Genset Rating (kVA): 1563.0	Rated Current: 1880.0
Duty: STANDBY	Connection: PARALLEL STAR	Pwr. Factor: 0.8	Status: Current
		Application: EPG	Version: 20224 / 20224 / 20224 / 677642

Generator Cooling Requirements - Temperature - Insulation Data	
Cooling Requirements:	Temperature Data: (Ambient 40 °C)
Heat Dissipated: 46.8 kW	Stator Rise: 125.0 °C
Air Flow: 108.0 m ³ /min	Rotor Rise: 125.0 °C
Insulation Class: H	
Insulation Reg. as shipped: 100.0 MΩ minimum at 40 °C	
Thermal Limits of Generator	
Frequency:	60 Hz
Line to Line Voltage:	480 Volts
B BR 80/40	1248.0 kVA
F BR -105/40	1440.0 kVA
H BR - 125/40	1563.0 kVA
H PR - 150/40	1630.0 kVA

Engine: C32
 Fuel: Diesel
 Frequency: 60
 Duty: STANDBY

Generator Frame: E3875L4
 Generator Arrangement: 6145658
 Excitation Type: Permanent Magnet
 Connection: PARALLEL STAR

Selected Model
 Genset Rating (kW): 1250.0
 Genset Rating (kVA): 1563.0
 Pwr. Factor: 0.8
 Application: EPG

Line Voltage: 480
 Phase Voltage: 277
 Rated Current: 1880.0
 Status: Current

Version: 20224 / 20224 / 20224 / 677642

**Starting Capability & Current Decrement
 Motor Starting Capability (0.6 pf)**

SKVA	Percent Volt Dip
269	2.5
519	5.0
807	7.5
1,071	10.0
1,368	12.5
1,652	15.0
1,964	17.5
2,304	20.0
2,669	22.5
3,067	25.0
3,580	27.5
4,132	30.0
5,023	32.5
5,491	35.0
6,209	37.5
6,919	40.0

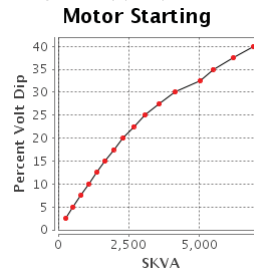

Current Decrement Data

E Time Cycle	AMP
0.0	21,568
1.0	14,428
2.0	11,471
3.0	10,177
4.0	9,553
5.0	9,201
8.0	8,713
10.0	8,394
13.0	8,067
15.0	7,841
20.0	7,460
25.0	7,205
30.0	7,028
35.0	6,906
40.0	6,822
45.0	6,765

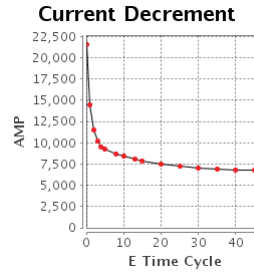

Instantaneous 3 Phase Fault Current: 25989 Amps

Instantaneous Line - Neutral Fault Current: 28038 Amps

Instantaneous Line - Line Fault Current: 18764 Amps

Engine: C32
 Fuel: Diesel
 Frequency: 60
 Duty: STANDBY

Generator Frame: E3875L4
 Generator Arrangement: 6145658
 Excitation Type: Permanent Magnet
 Connection: PARALLEL STAR

Selected Model
 Genset Rating (kW): 1250.0
 Genset Rating (kVA): 1563.0
 Pwr. Factor: 0.8
 Application: EPG

Line Voltage: 480
 Phase Voltage: 277
 Rated Current: 1880.0
 Status: Current

Version: 20224 / 20224 / 20224 / 677642

**Reactive Capability Curve
 Operating Chart**

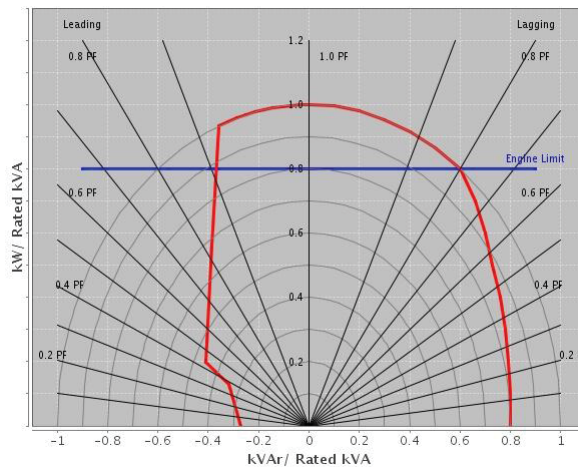

Engine: C32
 Fuel: Diesel
 Frequency: 60
 Duty: STANDBY

Generator Frame: E3875L4
 Generator Arrangement: 6145658
 Excitation Type: Permanent Magnet
 Connection: PARALLEL STAR

Selected Model
 Genset Rating (kW): 1250.0
 Genset Rating (kVA): 1563.0
 Pwr. Factor: 0.8
 Application: EPG

Line Voltage: 480
 Phase Voltage: 277
 Rated Current: 1880.0
 Status: Current

Version: 20224 / 20224 / 20224 / 677642

General Information

DM7802
GENERATOR GENERAL INFORMATION

I. GENERATOR MOTOR STARTING CAPABILITY CURVES
A. THE MOTOR STARTING CURVES ARE REPRESENTATIVE OF THE DATA OBTAINED BY THE FOLLOWING PROCEDURE:
1. THE CATERPILLAR GENERATOR IS DRIVEN BY A SYNCHRONOUS DRIVER.
2. VARIOUS SIZE THREE PHASE INDUCTION MOTORS (NEMA CODE F) ARE STARTED ACROSS THE LINE LEADS OF THE UNLOADED GENERATOR.
3. THE RESULTING VOLTAGE DIPS ARE RECORDED WITH AN OSCILLOSCOPE.
4. MOTOR HORSEPOWER HAS BEEN CONVERTED TO STARTING KILOVOLT AMPERES (SKVA).
5. RECORDED VOLTAGE DIPS HAVE BEEN EXPRESSED AS A OF GENERATOR RATED VOLTAGE.

II. USE OF THE MOTOR STARTING CAPABILITY CURVES.
A. CALCULATE THE SKVA REQUIRED BY THE MOTOR FOR FULL VOLTAGE STARTING ACROSS THE LINE IF THE VALUE IS NOT LISTED ON THE MOTOR DATA PLATE.

1. MOTORS CONFORMING TO NEMA STANDARDS
MULTIPLY THE MOTOR HORSEPOWER BY THE NEMA SKVA/HP FIGURE. FOR NEMA CODE F, USE 5.3 SKVA/HP; FOR NEMA CODE G, USE 6.0 SKVA/HP.

2. ALL OTHER MOTORS:
MULTIPLY THE RATED VOLTAGE BY THE LOCKED ROTOR AMPERE AND BY 0.001732. (IF THE LOCKED ROTOR AMPERES ARE NOT LISTED, MULTIPLY THE FULL LOAD (RUNNING) AMPERES BY B. USE THE ABOVE SKVA WITH THE MOTOR STARTING TABLE.

1. ACROSS LINE STARTING:
READ ACROSS THE ROW OF "ACROSS THE LINE STARTING SKVA IF THE DESIRED VALUE OF SKVA IS NOT GIVEN, CALCULATE THE DIP BY FINDING THE PROPER SKVA INTERVAL AND INTERPOLATING AS FOLLOWS:

SKVA1 IS THE SKVA TABLE ENTRY JUST SMALLER THAN THE DESIRED SKVA, DIP1 IS THE DIP FOR SKVA2, AND SKVA2 IS THE SKVA TABLE ENTRY JUST GREATER THAN THE DESIRED SKVA. THE DIP (IN PERCENT) AT THE DESIRED SKVA IS:

$$\text{DIP} = \text{DIP1} + (\text{SKVA} - \text{SKVA1}) * 2.5 / (\text{SKVA2} - \text{SKVA1})$$

NOTE: VOLTAGE DIPS GREATER THAN 35% MAY CAUSE MAGNETIC CONTACTORS TO DROP OUT.

2. REDUCED VOLTAGE STARTING:
REFER TO THE FOLLOWING TABLE. MULTIPLY THE CALCULATE ACROSS LINE SKVA BY THE MULTIPLIER LISTED FOR THE SPECIFIC STARTING METHOD. APPLY THE RESULT TO THE STARTING TABLE AS IN II A, TO CALCULATE THE EXPECTED VOLTAGE DIP:

TYPE OF REDUCED VOLTAGE STARTING	MULTIPLY LINE SKVA BY
80% TAP	.80
65% TAP	.65
50% TAP	.50
45% TAP	.45
Wye start, delta run	.33

AUTOTRANSFORMER	
80% TAP	.68
65% TAP	.46
50% TAP	.29

NOTE: REDUCE VOLTAGE STARTING LOWERS THE MAXIMUM REQUIRED MOTOR skVA.

3. Part winding starting:

Most common is half-winding start, full-winding run. Multiply the full motor, across line starting skVA by 0.6. Apply the result to the selected curve as in ii. A above. Read the expected voltage dip, for the required skVA.

III. DEFINITION:

A. GENERATOR TERMS

MODEL: Engine Sales model
ENG TYPE: DI = Direct Injection,
NA = Naturally aspirated, etc
HZ: Running frequency, hertz
RATING TYPE: PP, SB (prime power or standby)
KW: Base rating electrical kilowatts (ekW)
VOLTS: Rating terminal, line to line
GEN ARR: Cat generator arrangement part number
GEN FRAME: Generator frame size designation
CONN: Generator output connection
(star, wye, delta, ect.)

POLES: Number of pole pieces on rotor.
(eg. A 4 pole generator run at 1800 RPM will produce 60 Hz alternating current. A 6 pole generator run at 1200 RPM will produce 60 Hz alternating current.)

B. GENERATOR TEMPERATURE RISE:
The indicated temperature rise indicated the NEMA limits for standby or prime power applications. These rises are used for calculating the losses and efficiencies and are not necessarily indicative of the actual temperature rise of a given machine.

C. CENTER OF GRAVITY

The specified center of gravity is for the generator only. For single bearing, and two bearing close coupled generators, the center of gravity is measured from the generator/engine flywheel housing interface and from the centerline of the rotor shaft.

For two bearing, standalone generators, the center of gravity is measured from the end of the rotor shaft and from the centerline of the rotor shaft.

For two bearing, standalone generators, the center of gravity is measured from the end of the rotor shaft and from the centerline of the rotor shaft.

D. GENERATOR DECREMENT CURRENT CURVES

The generator decrement current curve gives the symmetrical current supplied by the generator for a three phase bolted fault at the generator terminals. Generators equipped with the series boost attachment or generators with PM excitation system will supply 300% of rated current for at least 10 seconds.

E. GENERATOR EFFICIENCY CURVES

The efficiency curve is representative of the overall

AIR INTAKE SYSTEM		
<i>THE INSTALLED SYSTEM MUST COMPLY WITH THE SYSTEM LIMITS BELOW FOR ALL EMISSIONS CERTIFIED ENGINES TO ASSURE REGULATORY COMPLIANCE.</i>		
MAXIMUM ALLOWABLE INTAKE RESTRICTION WITH CLEAN ELEMENT	15	IN-H2O
MAXIMUM ALLOWABLE INTAKE RESTRICTION WITH DIRTY ELEMENT	25	IN-H2O
MAXIMUM PRESSURE DROP FROM COMPRESSOR OUTLET TO MANIFOLD INLET (OR MIXER INLET FOR EGR)	4.4	IN-HG
MAXIMUM AIR FILTER INLET AIR TEMPERATURE	122	DEG F
COOLING SYSTEM		
MAXIMUM ALLOWABLE JACKET WATER OUTLET TEMPERATURE	210	DEG F
REGULATOR LOCATION FOR JW (HT) CIRCUIT	OUTLET	
MAXIMUM UNINTERRUPTED FILL RATE	5.0	G/MIN
MINIMUM COOLANT LOSS WITHOUT IMPACTING RADIATOR PERFORMANCE (PERCENT OF TOTAL)	12	PERCENT
COOLANT LOSS-MAXIMUM PERCENTAGE OF PUMP PRESSURE RISE LOSS	10	PERCENT
ENGINE SPEC SYSTEM		
CYLINDER ARRANGEMENT	VEE	
NUMBER OF CYLINDERS	12	
CYLINDER BORE DIAMETER	5.7	IN
PISTON STROKE	6.4	IN
TOTAL CYLINDER DISPLACEMENT	1959	CU IN
NUMBER 1 CYLINDER LOCATION	LEFT FRONT	
STROKES/COMBUSTION CYCLE	4	
EXHAUST SYSTEM		
<i>THE INSTALLED SYSTEM MUST COMPLY WITH THE SYSTEM LIMITS BELOW FOR ALL EMISSIONS CERTIFIED ENGINES TO ASSURE REGULATORY COMPLIANCE.</i>		
MAXIMUM ALLOWABLE SYSTEM BACK PRESSURE	27	IN-H2O
FUEL SYSTEM		
MAXIMUM FUEL FLOW FROM TRANSFER PUMP TO ENGINE	227.2	G/HR
MAXIMUM ALLOWABLE FUEL SUPPLY LINE RESTRICTION	-8.9	IN-HG
MAXIMUM ALLOWABLE FUEL TEMPERATURE AT TRANSFER PUMP INLET	149	DEG F
MAXIMUM FUEL FLOW TO RETURN LINE FROM ENGINE	190.2	G/HR
MAXIMUM ALLOWABLE FUEL RETURN LINE RESTRICTION	10.2	IN-HG
NORMAL FUEL PRESSURE IN A CLEAN SYSTEM	90.9	PSI
FUEL SYSTEM TYPE	EUI	
MAXIMUM TRANSFER PUMP PRIMING LIFT WITHOUT PRIMING PUMP	12.1	FT
LUBE SYSTEM		
CRANKCASE VENTILATION TYPE	TO ATM	
MOUNTING SYSTEM		
CENTER OF GRAVITY LOCATION - X DIMENSION - FROM REAR FACE OF BLOCK - (REFERENCE TM7077)	23.0	IN
CENTER OF GRAVITY LOCATION - Y DIMENSION - FROM CENTERLINE OF CRANKSHAFT - (REFERENCE TM7077)	11.5	IN
CENTER OF GRAVITY LOCATION - Z DIMENSION - FROM CENTERLINE OF CRANKSHAFT - (REFERENCE TM7077)	0	IN
DRY WEIGHT - ENGINE ONLY (REFERENCE VALUE)	6462	LB
STARTING SYSTEM		
LOWEST AMBIENT START TEMPERATURE WITHOUT AIDS	32	DEG F

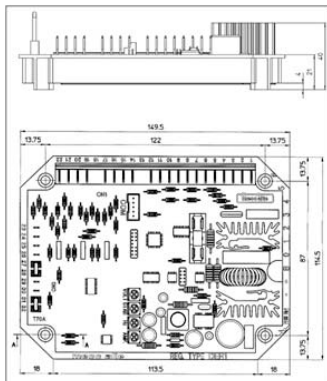

Image shown might not reflect actual configuration

Technical Specifications

Maximum current	5A (Continuous)
Forced excitation current for 1 minute	10A
Power Input (Aux winding or PMG)	Voltage: 40Vac to 270Vac
	Frequency: 12Hz to 72Hz
Sensing voltage	Range 1: 75Vac to 150Vac
	Range 2: 150Vac to 300Vac
Voltage Regulation (Steady state)	<±0.54%
Analog input (A1-A2)	0Vdc - 2.5V dc
	-10Vdc to +10Vdc
External Volts Adjustment	±10% with 100k ohm Pot
Operating temperature:	-25°C to +70°C
Dimensions (L x W x H)	149.5mm x 114.5mm x 40mm

DER1- Automatic Voltage Regulator

The DER1 is a voltage regulator for 50 or 60 Hz synchronous alternators Internally excited brushless type SR500 frame generators. The AVR circuitry includes under speed and overload protection.

Features

- All parameters on the AVR can be programmed using a USB connector and a computer or through potentiometers
- Genset output voltage can be altered by adjusting the onboard potentiometer "VOLT"
- Onboard overload setting can be altered by adjusting the onboard potentiometer "AMP" which allows the user to set the overload limit and has LED indication to show overload condition & Protection activated* (after time delay)
- "HZ" potentiometer adjusts the under speed protection with respect to the nominal speed value set by the 50/60 hz jumper
- "STAB" potentiometer adjusts the dynamic response of the alternator under transient response
- Remote control of voltage available with a range of 0Vdc to 2.5Vdc or -10Vdc to +10Vdc.

*flash rate varies in each protection activated!

www.cat.com/electricpower

©2021 Caterpillar

All rights reserved.

Materials and specifications are subject to change without notice.

The International System of Units (SI) is used in this publication.

LET'S DO THE WORK.™

LEHE20369-00 (09/21)

CAT, CATERPILLAR, LET'S DO THE WORK, their respective logos, "Caterpillar Corporate Yellow," the "Power Edge" and Cat "Modern Hex" trade dress as well as corporate and product identity used herein, are trademarks of Caterpillar and may not be used without permission.

This page intentionally left blank



ADEM™ A4 Engine Controller

The ADEM™ A4 is the main Electronic Control Module (ECM) used on select diesel engines. The ADEM A4 provides a higher degree of control over a large number of combustion variables. The ADEM A4 is designed to control/interface Electronic Unit Injector (EUI) equipped engines. The ADEM A4 engine system is composed of the ADEM A4 ECM, control software, sensors, actuators, fuel injectors, and interface to the generator system. The prime benefit of an ADEM A4 engine system is to better control and maintain the particulate emissions, both steady state and transient, while improving engine performance.

Features

Reliable, Durable

All ADEM A4 controllers are designed to survive the harshest environments.

- Environmentally sealed, die-cast aluminum housing isolates and protects electronic components from moisture and dirt contamination
- Rigorous vibration testing ensures product reliability and durability
- Accuracy maintained from -40°C to 85°C
- Electrical noise immunity to 100 volts / meter
- Internal circuits are designed to withstand shorts to + battery and – battery

Simple Servicing

Each ADEM A4 system works in combination with the Cat® ET service tool software to keep the engine operating at peak performance.

- Displays measured parameters
- Retrieves active and logged event code documenting abnormal system operation
- Performs calibrations and diagnostic tests
- Supports flash programming of new software into the ADEM A4 ECM

Self Diagnostics

Each ADEM A4 ECM has a full compliment of diagnostics. The ECM can detect faults in the electrical system and report those faults to the service technician for quick repair.

- Self-diagnostic capability pinpoints operational problems in need of attention.

Advanced Features

- Enhanced performance from fuel injection timing and limiting
- Adjustable monitoring of vital engine parameters
- Programmable speed acceleration ramp rate
- Data link interfaces

Description

The ECM is housed in an environmentally sealed cast-iron. All wiring connections to the ECM are made using two sealed connectors: a single seventy-pin connector and a single one hundred twenty-pin connector.

Engine Speed Governing

Desired engine speed is calculated by the ECM and held within ± 0.2 Hz for isochronous and droop mode. The ECM accounts for droop that is requested. The proper amount of fuel is sent to the injectors due to these calculations. The ECM also employs cooldown/shutdown strategies, acceleration delays on startup, acceleration ramp times and speed reference.

Fuel Limiting

Warm and cold fuel-air ratio control limits are controlled by the ECM. Electronic monitoring system derates, torque limit, and cranking limit, programmable torque scaling, and cold cylinder cutout mode are standard features.

Fuel Injection Timing

Master timing for injection is controlled by the ECM control. Temperature dependencies are accounted for in the fuel injection calculations.

Electronic Monitoring

Electronic monitoring of vital engine parameters can be programmed. Warning, derate, and shutdown event conditions may be customized by the user.

Information Management

The ECM stores information to assist with electronic troubleshooting. Active and logged diagnostic codes, active events, logged events, fuel consumption, engine hours, and instantaneous totals aid service technicians when diagnosing electronic faults and scheduling preventive maintenance.

Calibrations

Engine performance is optimized through injection timing. Auto/manual sensor calibrations are standard features.

On-Board System Tests

System tests are available to assist in electronic troubleshooting. These tests include: injector activation, injector cutout, and override of control outputs.

Data Link Interfaces

The ADEM A4 communicates with the EMCP via a dedicated communication network.

Electronic Sensing

The following sensing is available on the ADEM A4: oil pressure, fuel pressure, fuel temperature, atmospheric pressure, air inlet temperature, turbo outlet pressure, engine coolant temperature, engine speed, throttle position, exhaust temperature, oil filter pressure differential, fuel filter pressure differential, air filter pressure differential and crankcase pressure.

SPECIFICATIONS

Impervious to:

Salt spray, fuel, oil and oil additives, coolant, spray cleaners, chlorinated solvents, hydrogen sulfide and methane gas, and dust.

Input and output protection

All inputs and outputs are protected against short circuits to +battery and –battery

Input voltage range (24 VDC nominal)

18 to 32 VDC

Mounting

Engine mounted

Reverse polarity protected

Shock, withstands 20g

Temperature range

Operating: –40°C to 85°C (–40°F to 185°F)

Storage: –50°C to 120°C (–58°F to 248°F)

Vibration

Withstands 8.0g @ 24 to 2 kHz

Information contained in this publication may be considered confidential. Discretion is recommended when distributing.

Materials and specifications are subject to change without notice.

CAT, CATERPILLAR, LET'S DO THE WORK, their respective logos, "Caterpillar Yellow," the "Power Edge" and Cat "Modern Hex" trade dress as well as corporate and product identity used herein, are trademarks of Caterpillar and may not be used without permission.

This page intentionally left blank



Image shown might not reflect actual configuration

G CCP 1.2 - Control Panel

G CCP 1.2 is an auto Start Control Module suitable for a wide variety of diesel gen-set applications. Monitoring an extensive number of engine parameters, the modules will display warnings, shutdown and engine status information on the backlit LCD screen, illuminated LEDs and remote PC.

FEATURES

- 4-line back-lit LCD text display
- Multiple display languages
- Five-key menu navigation
- LCD alarm indication
- Customisable power-up text and images
- Data logging facility
- Internal PLC editor
- Protections disable feature
- Fully configurable via PC using USB & RS485 communication
- Front panel configuration with PIN protection
- Power save mode
- 3-phase generator sensing and protection
- Generator current and power monitoring (kW, kvar, kVA, pf)
- kW and kvar overload and reverse power alarms
- Over current protection
- Unbalanced load protection
- Breaker control via fascia buttons
- Fuel and start outputs configurable when using CAN Support for 0 V to 10 V & 4 mA to 20 mA sensors
- 8 configurable digital inputs (3 available for Customer use)
- 8 configurable digital outputs (5 available for Customer use)
- 4 configurable analogue inputs (3 available for Customer Use)
- CAN, MPU and alternator frequency speed sensing in one variant
- Real time clock
- Engine pre-heat and post-heat functions
- Engine run-time scheduler
- Engine idle control for starting & stopping
- Fuel usage monitor and low fuel level alarms
- 3 configurable maintenance alarms

BENEFITS

- Hours counter provides accurate information for monitoring and maintenance periods
- User-friendly set-up and button layout for ease of use
- Multiple parameters are monitored & displayed simultaneously for full visibility
- The module can be configured to suit a wide range of applications for user flexibility
- PLC editor allows user configurable functions to meet user specific application requirements.
- RS485 Communication port can be used for the Remote Monitoring Communication (Compatible with Cat PLG)

SPECIFICATION

DC SUPPLY

CONTINUOUS VOLTAGE RATING

8 V to 35 V Continuous
5 V for upto 1 minute

CRANKING DROPOUTS

Able to survive 0 V for 100 mS, providing supply was at least 10 V before dropout and supply recovers to 5 V. This is achieved without the need for internal batteries.

LEDs and backlight will not be maintained during cranking.

MAXIMUM OPERATING CURRENT

260 mA at 12 V, 150 mA at 24 V

MAXIMUM STANDBY CURRENT

145 mA at 12 V, 85 mA at 24 V

CHARGE FAIL/EXCITATION RANGE

0 V to 35 V

GENERATOR & MAINS (UTILITY) VOLTAGE RANGE

15 V to 415 V AC (Ph to N)
26 V to 719 V AC (Ph to Ph)

FREQUENCY RANGE

3.5 Hz to 75 Hz

MAGNETIC PICKUP VOLTAGE RANGE

+/- 0.5 V to 70 V

FREQUENCY RANGE

10,000 Hz (max)

INPUTS

DIGITAL INPUTS A TO H

Negative switching

ANALOGUE INPUTS A & D

Configurable as:

Negative switching digital input 0 V to 10 V sensor
4 mA to 20 mA sensor Resistive sensor

ANALOGUE INPUTS B & C

Configurable as:

Negative switching digital input Resistive sensor

OUTPUTS

OUTPUT A & B (FUEL & START)

15 A DC at supply voltage

AUXILIARY OUTPUTS C, D, E, F, G & H

2 A DC at supply voltage

DIMENSIONS OVERALL

216 mm x 158 mm x 43 mm
8.5" x 6.2" x 1.5"

PANEL CUT-OUT

184 mm x 137 mm
7.2" x 5.3"

MAXIMUM PANEL THICKNESS

8 mm
0.3"

STORAGE TEMPERATURE RANGE

-40°C to +85°C
-40 °F to +185 °F

OPERATING TEMPERATURE RANGE

-30°C to +70°C
-22 °F to +158 °F

This page intentionally left blank

CARTER POWER SYSTEMS

Section Three ACCESSORIES CUTSHEETS

Sound Attenuated Enclosure
Circuit Breakers
Generator Space Heater
Discrete I/O Module
Remote Annunciator and Alarm Modules
Remote Annunciator Wiring Diagrams
Recommended Cable for Remote Annunciator
Batteries
Battery Charger
Jacket Water Heater
Warranty
Extended Service Coverage
Value Planned Maintenance

This page intentionally left blank



Image shown may not reflect actual configuration.

C27 – C32 GC Enclosures NA

Sound Attenuated Enclosures for C27 and C32 GC Generator Sets

These sound attenuated, factory installed enclosures are designed for safety and aesthetic value. Rugged construction provides weather protection and the ability to withstand exposure to the elements

FEATURES

Robust/Highly Corrosion-Resistant Construction

- Environmentally friendly, polyester powder-baked paint in Caterpillar White
- Zinc Plated and Stainless Steel Fasteners
- 14-Gauge Steel Construction
- Flat Roof with protection for water ingress from Rain
- Critical Grade internally mounted muffler/exhaust system
- Soft Mounted isolators
- 75 dbA @ 7m (Target value) for Sound attenuated enclosures

Excellent Access

- Control panel mounted on RH side with an optional auxiliary box on the LH side of the package
- Large cable entry area for the ease of installation
- Left-hand or Right-hand bottom entry access to power cable bus or circuit breaker
- Multiple doors on both sides allow easy access to service points
- Hinged doors allow 180° opening rotation
- Lube Oil and coolant drains piped to exterior of enclosure and terminated drain valves
- Radiator fill cover

Options

- Weather Proof Enclosure available with same footprint
- Interior DC lighting systems
- [Caterpillar White Paint \(Default\)](#)
- 2100 (Factory installed), 3000 and 4200 (shipped loose) gallon fuel tanks
- 100 mph wind loading

Security and Safety

- Lockable access doors with standard key use
- Cooling fan and battery charging alternator fully guarded
- Oil fill and battery can only be reached via lockable access
- External fuel connections
- Externally mounted emergency stop buttons
- Designed for spreader bar lifting to ensure safety

Certifications

- UL 2200 listed & cUL
- Seismic certification per applicable building codes: IBC 2018, CBC 2007
- Analysed to withstand 100mph wind loading
- Tested and analysed in accordance with: ASCE 7-98, ASCE 7-02, ASCE 7-05, ICC-ES AC-156

Enclosure Weights and Dimensions

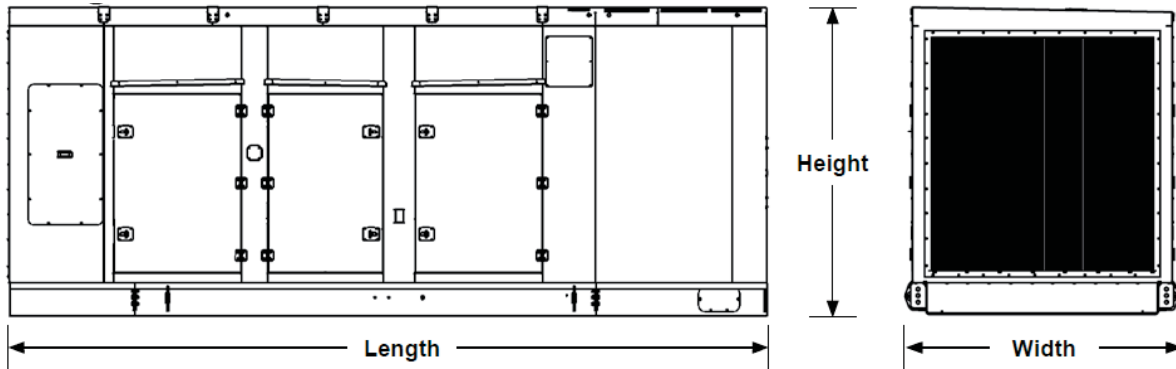

Note: For reference only – do not use for installation design. Please contact your dealer for exact weights and dimensions.

Enclosure Base Options*				
	Weight kgs (lbs)	Length mm (in)	Width mm (in)	Height mm (in)
With Lifting Base	2672 (5891)	6196 (244)	2300 (91)	2650 (104)
With 2100 gal integral tank base	4891 (10783)	7620 (300)	2349.5 (93)	3264.4 (129)
With 3000 gal tank with lifting base	5638 (12429)	7645 (301)	2349.5 (93)	2650 (104)
With 4200 gal tank with lifting base	6563 (14468)	7645 (301)	2349.5 (93)	2650 (104)

*Weight does not include package generator set weight.

Generator Set Weights

Generator Set Weights**	Weight kgs (lbs)
C27 Open Generator Set	5813 (12815)
C32 Open Generator Set	6798 (14987)

**Dry Weight of heaviest configuration and without base rail weight (Does not include exhaust system weights)

LET'S DO THE WORK.™

www.cat.com/electricpower

©2021 Caterpillar

All rights reserved.

Materials and specifications are subject to change without notice.

The International System of Units (SI) is used in this publication. CAT, CATERPILLAR,

LET'S DO THE WORK, their respective logos, "Caterpillar Corporate Yellow"

the "Power Edge" and Cat "Modern Hex" trade dress as well as corporate and product

identity used herein, are trademarks of Caterpillar and may not be used without permission.



L Frame



P Frame



R Frame

Molded Case Circuit Breakers

C27 – C32 North America built packages (60 Hz)

L-Frame
250A-400A (UL)

P-Frame
1200A (UL)

R-Frame
1600-2000A (UL)

Features

Design Specifications:

- Moisture and fungus protection
- Clear indication of breaker status
- Reinforced insulation
- Shunt trip
- Auxiliary contacts
- Load side extension bars
- Maintenance-free operation
- Exceptional characteristics under short-circuit conditions
- Adjustable trip settings

L-Frame

UL 489
CSA 22.2 No 5
Federal Specification W-C-375B/GEN
NEMA AB1
NMX J-266 CCC
CE Marking

P-Frame & R-Frame

UL 489
CSA 22.2 No 5-02
Federal Specification W-C-375B/GEN
NEMA AB1
NMX J-266

Standard Features

Standards

- UL-CSA
 - L-Frame
 - P-Frame
 - R-Frame

Shunt trip

- The shunt trip provides a means of tripping the circuit breaker electronically
- Shunt trip ratings
 - Voltage: 24VDC
 - Coil Burden (Holding/Inrush): 4.5/200 VA
 - Power Consumption: 4.5 VA

Auxiliary contacts

The auxiliary contacts provide a means of remote circuit breaker position indication and consists of (1) Form C Contact (1 Normally open and 1 Normally closed contact) with the following current ratings:

6A @ 240-480 VAC, 50/60 Hz

Trip units

All circuit breakers come equipped with True RMS Current Sensing.

The trip units for each of the circuit breaker ratings sample the current waveform to provide true RMS protection through the 15th harmonic. This true RMS sensing gives accurate values for the magnitude of a nonsinusoidal waveform.

Therefore, the heating effects of harmonically distorted waveforms are accurately evaluated. The trip system comes equipped with a set of current transformers (CT's) to sense current, a trip unit to evaluate the current, and a tripping solenoid to trip the circuit breaker.

Additionally, each trip unit comes equipped with Active Thermal Imaging which is active 20 minutes before and after tripping.

Customer cable connections

Extension bus bars or mechanical lugs are provided for installation of load cables.

Cat® Part Number	Frame and Rating (Amps)	IEC/UL	No. Poles	Operation	Trip Unit	Circuit Breaker Characteristics	Options	Instantaneous Override (kA RMS) +/- 10%
611-4994	250A L-Frame MCCB	UL	3	MO	3.3S LSI	Table 3	1 Aux Contact, Shunt Trip	–
421-3235	400A L-Frame MCCB	UL	3	MO	3.3S LSI	Table 3	1 Aux Contact, Shunt Trip	–
421-3237	400A L-Frame MCCB	UL	3	MO	6.3A LSIG	Table 3	1 Aux Contact, Shunt Trip	–
244-9774	1200A P-Frame MCCB	UL	3	MO	5.0A LSI	Table 1	1 Aux Contact, Shunt Trip	24
244-9864	1600A R-Frame MCCB	UL	3	MO	5.0A LSI	Table 2	1 Aux Contact, Shunt Trip	57
244-9868	2000A R-Frame MCCB	UL	3	MO	5.0A LSI	Table 2	1 Aux Contact, Shunt Trip	57
244-9778	1200A P-Frame MCCB	UL	3	MO	6.0A LSIG	Table 1	1 Aux Contact, Shunt Trip	24
244-9865	1600A R-Frame MCCB	UL	3	MO	6.0A LSIG	Table 2	1 Aux Contact, Shunt Trip	57
244-9869	2000A R-Frame MCCB	UL	3	MO	6.0A LSIG	Table 2	1 Aux Contact, Shunt Trip	57
244-9790	1200A P-Frame MCCB	UL	3	MO	6.0P LSIG-P	Table 1	1 Aux Contact, Shunt Trip, Modbus	24
585-8063	1600A R-Frame MCCB	UL	3	MO	6.0P LSIG-P	Table 2	1 Aux Contact, Shunt Trip, Modbus	57
585-8064	2000A R-Frame MCCB	UL	3	MO	6.0P LSIG-P	Table 2	1 Aux Contact, Shunt Trip, Modbus	57

Circuit Breakers Characteristics

TABLE 1

Model		P-Frame	
Number of Poles		3	
Rated Current (Amps)		1200A (UL)	
Voltage Rating (VAC)		600UL/ 690 IEC	
Interrupt Rating (UL/CSA) (60 Hz) – kA RMS		240V	65
		480V	35
		600V	18
IEC 60947-2 Rating (50/60 Hz) – kA RMS	Icu	240V	50
		380/415V	35
	Ics	240V	25
		380/415V	20

TABLE 3

Model		L-Frame	
Number of Poles		3	
Rated Current (Amps)		250A – 400A (UL)	
Voltage Rating (VAC)		600UL/ 525 IEC	
Interrupt Rating (UL/CSA) (60 Hz) – kA RMS		240V	65
		480V	35
		600V	18
IEC 647-2 Rating (50/60 Hz) – kA RMS	Icu	240V	50
		380/415V	35
	Ics	240V	25
		380/415V	20

TABLE 2

Model		R-Frame	
Number of Poles		3	
Rated Current (Amps)		1600A – 2000A (UL)	
Voltage Rating (VAC)		600UL/ 690 IEC	
Interrupt Rating (UL/CSA) (60 Hz) – kA RMS		240V	65
		480V	35
		600V	18
IEC 60947-2 Rating (50/60 Hz) – kA RMS	Icu	240V	50
		380/415V	35
	Ics	240V	25
		380/415V	20

P, R, NS-Frame Long-Short Trip Curve and NW-Frame Long-Short Trip Curve

CURRENT IN MULTIPLES OF I_r (I_r = Long-time setting x I_n)

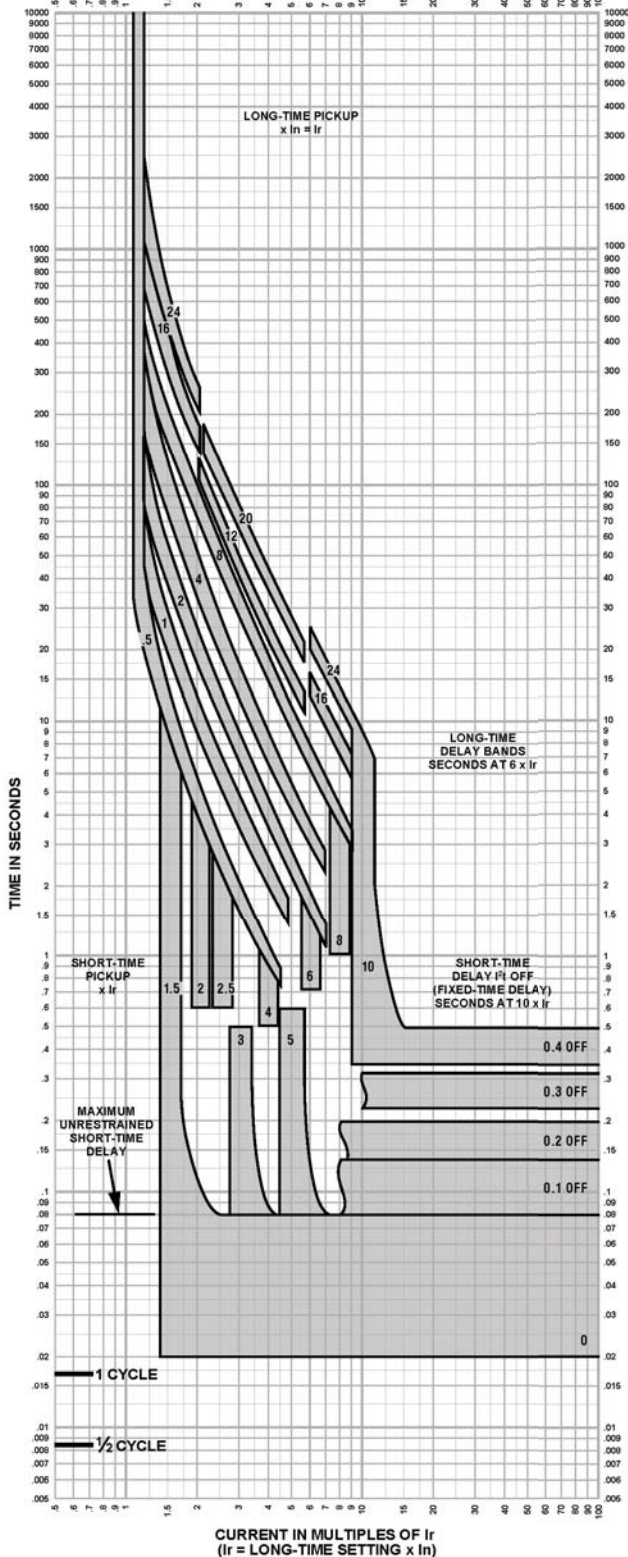

Long-time Pickup and Delay Short-time Pickup and I²t OFF Delay

The time-current curve information is to be used for application and coordination purposes only. Curves apply from -30°C to +60°C ambient temperature.

Notes:

1. There is a thermal-imaging effect that can act to shorten the long-time delay. The thermalimaging effect comes into play if a current above the long-time delay pickup value exists for a time and then is cleared by the tripping of a downstream device or the circuit breaker itself. A subsequent overload will cause the circuit breaker to trip in a shorter time than normal. The amount of time delay reduction is inverse to the amount of time that has elapsed since the previous overload. Approximately 20 minutes is required between overloads to completely reset thermalimaging.
2. The end of the curve is determined by the interrupting rating of the circuit breaker.
3. With zone-selective interlocking on, short-time delay utilized and no restraining signal, the maximum unrestrained short-time delay time band applies regardless of the setting.
4. Total clearing times shown include the response times of the trip unit, the circuit breaker opening, and the extinction of the current.
5. For a withstand circuit breaker, instantaneous can be turned OFF.
6. Overload indicator illuminates at 100%.

P, R, NS-Frame Instant Curve and NW-Frame Instant Trip Curve

MULTIPLES OF SENSOR RATING (I_n)

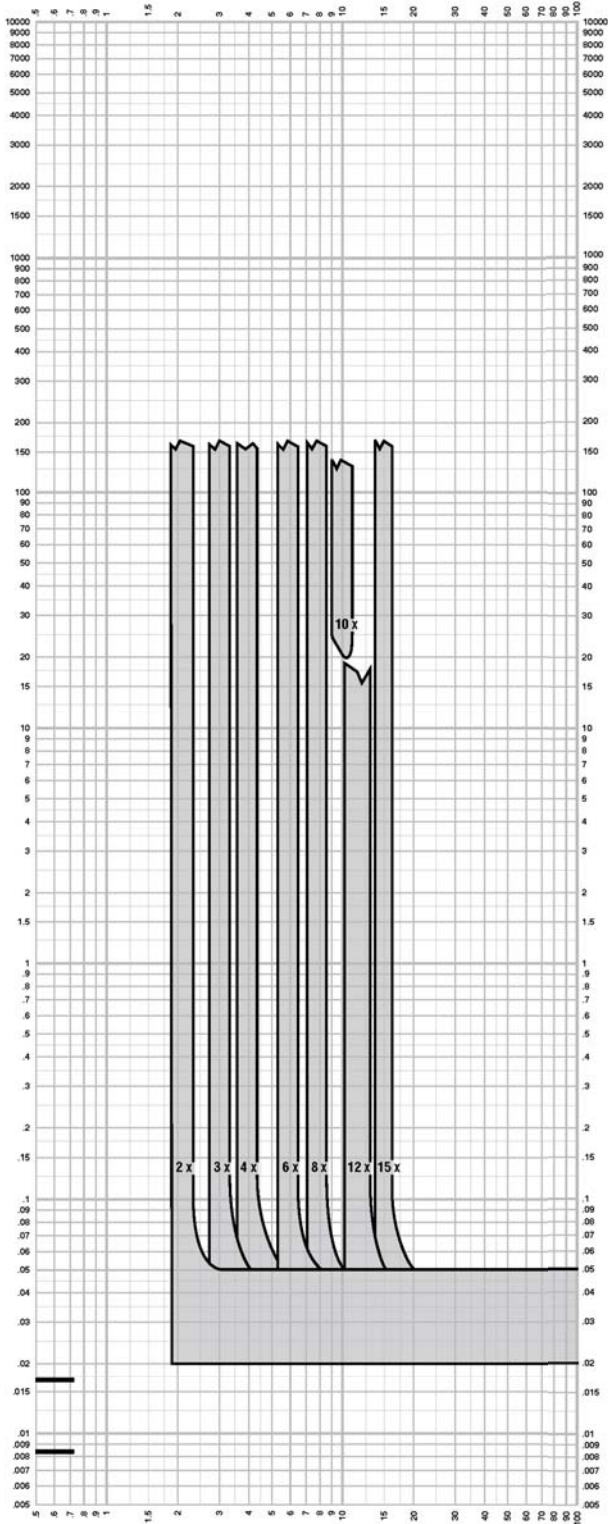

Instantaneous Pickup 2x–15x and OFF

The time-current curve information is to be used for application and coordination purposes only.

Curves apply from -30° to +60°C ambient temperature.

Notes:

1. The end of the curve is determined by the interrupting rating of the circuit breaker.
2. Total clearing times shown include the response times of the trip unit, the circuit breaker opening, and the extinction of the current.
3. The instantaneous region of the trip curve shows maximum total clearing times. Actual clearing times in this region can vary depending on the circuit breaker mechanism design and other factors. The actual clearing time can be considerably faster than indicated.
Contact your local Sales Office for additional information.
4. For a withstand circuit breaker, instantaneous can be turned OFF. \

P, R, NS-Frame Ground Curve and NW-Frame Ground Fault Trip Curve

MULTIPLES OF SENSOR RATING (I_n)

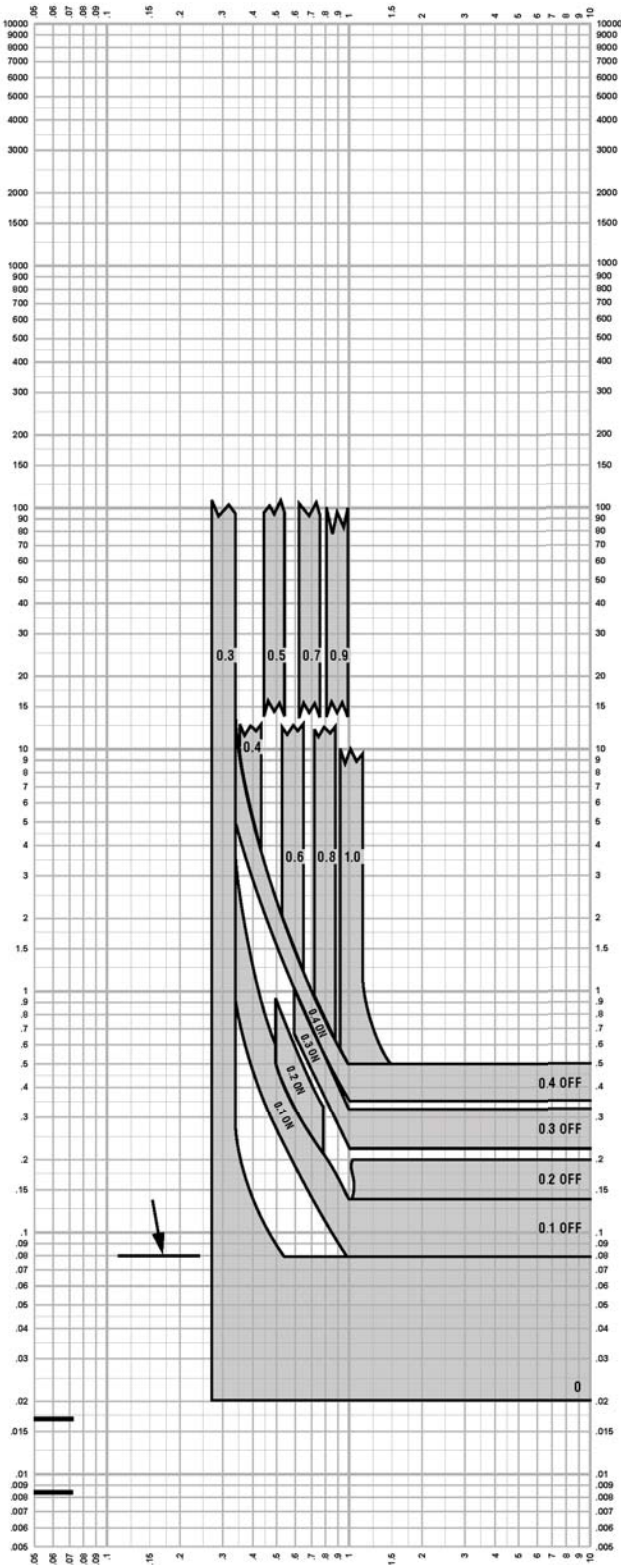

Ground-fault I^2t OFF and ON $I_n \leq 400$ A

The time-current curve information is to be used for application and coordination purposes only.

Curves apply from -30° to $+60^\circ$ C ambient temperature.

Circuit Breakers Characteristics

Models		NA8 Frame	
No. of Poles		3 / 4	
Rated Current (Amps)		1600A / 2000A / 2500A (IEC)	
Rated Voltage (VAC)		690	
IEC60947-2 Rating (50 Hz/60 Hz) kA RMS	Icu	230-400V	55
		690V	30
	Ics	230-400V	42
		690V	25

Tripping Characteristic Curve of Intelligent Controller

Overcurrent protection curves

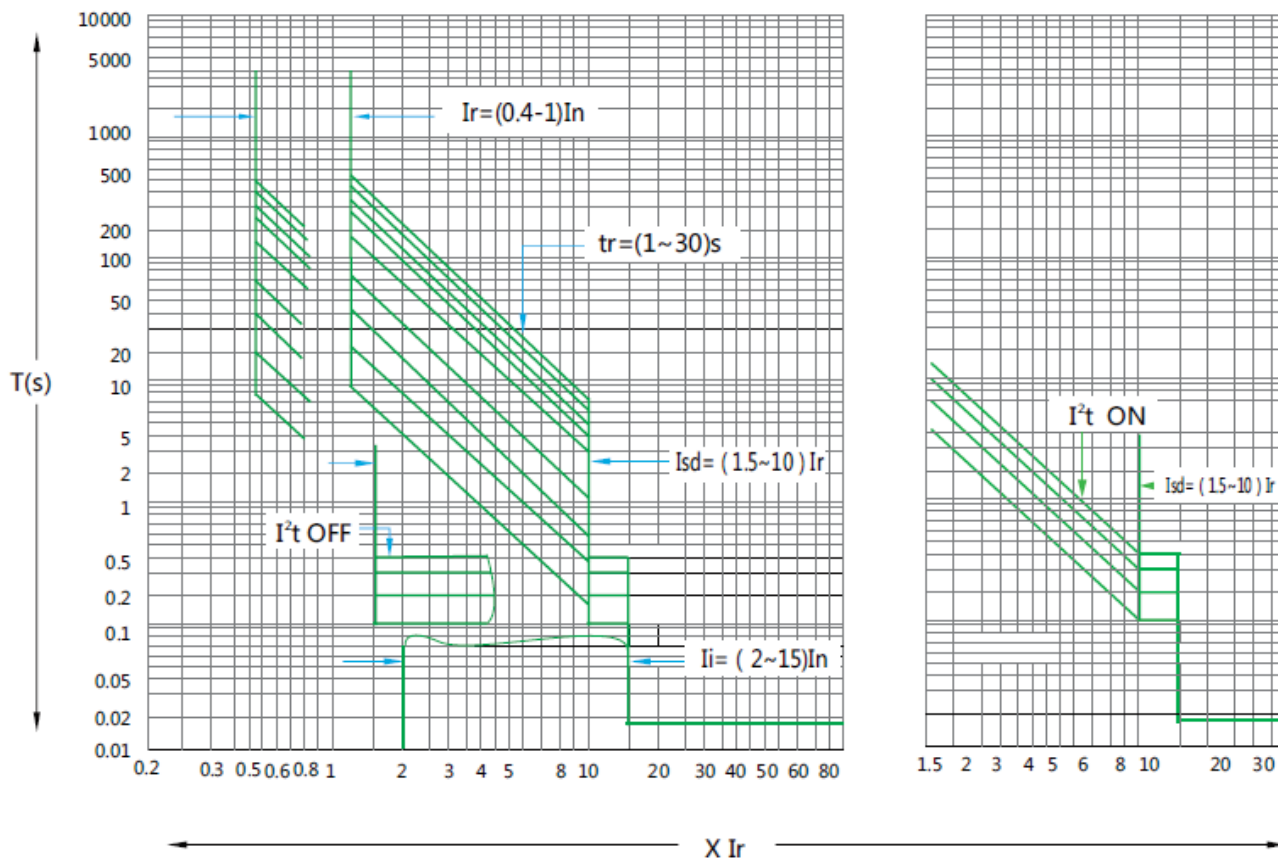

LET'S DO THE WORK.™

www.cat.com/electricpower

©2021 Caterpillar
All rights reserved.

Materials and specifications are subject to change without notice.

The International System of Units (SI) is used in this publication. CAT, CATERPILLAR, LET'S DO THE WORK, their respective logos, "Caterpillar Corporate Yellow" the "Power Edge" and Cat "Modern Hex" trade dress as well as corporate and product identity used herein, are trademarks of Caterpillar and may not be used without permission.

Generator Space Heater for SR500 E3800 Frame Generators

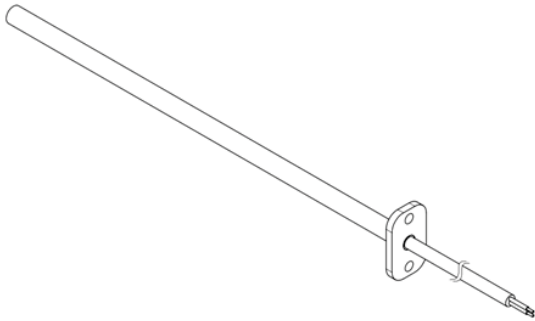

Picture shown may not reflect actual configuration

General Description

Humidity is a natural enemy of generators and all electrical equipment.

Space heaters are designed to protect generator windings from abnormally high humidity conditions when the generator is idle. The heater maintains the air around the windings at a suitable temperature to prevent winding corrosion due to condensation.

Generator space heaters use electrical resistance and are located within the generator stator housing.

Space heaters are particularly recommended for generator sets located in a low ambient and/or high humidity environment. As a further benefit, space heaters provide an excellent method of drying out a generator after long transit or storage.

Because space heaters are required only during non-operative periods, they require availability of a power source separate from the generator set itself.

When the generator set is not running the heater automatically connects to the AC supply through a power relay mounted in the control panel. Upon receiving a start signal the AC supply is automatically disconnected by the power relay and automatically reconnected when the start signal is removed.

VOLTAGE (V)	POWER (W)
208	85
230	103
255	127
277	150

LET'S DO THE WORK.™

www.cat.com/electricpower

©2021 Caterpillar
All rights reserved.

Materials and specifications are subject to change without notice.

The International System of Units (SI) is used in this publication. CAT, CATERPILLAR, LET'S DO THE WORK, their respective logos, "Caterpillar Corporate Yellow" the "Power Edge" and Cat "Modern Hex" trade dress as well as corporate and product identity used herein, are trademarks of Caterpillar and may not be used without permission.

This page intentionally left blank

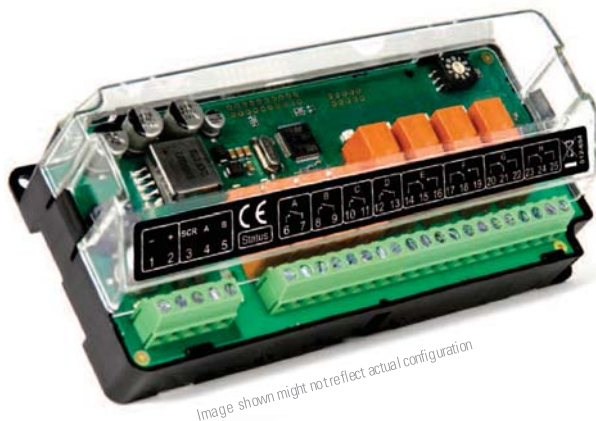

OUTPUT EXPANSION MODULE

Output relay expansion module for use with compatible control modules. The Output Expansion module has been designed to extend a host module's output capabilities.

A maximum of 10 Output Expansion modules can be connected to an individual module at any one time. All outputs are configurable via the host controller.

The module will work up to 1 KM (0.6miles) from the host control module

FEATURES

- Power On/Link Lost LED ID SWITCH
- 10 expansion modules can be connected to 1 host controller at a time
- 8 configurable relay contacts with LED indicators:
- 4 Normally Open (N/O)
- 4 Change Over (C/O)
- Terminal strip connection for quick and easy set-up

ENVIRONMENTAL TESTING STANDARDS

ELECTRO-MAGNETIC COMPATIBILITY

BS EN 61000-6-2
EMC Generic Immunity Standard for the Industrial Environment
BS EN 61000-6-4
EMC Generic Emission Standard for the Industrial Environment

ELECTRICAL SAFETY

BS EN 60950
Safety of Information Technology Equipment, including Electrical Business Equipment

TEMPERATURE

BS EN 60068-2-1
Ab/Ae Cold Test -30 °C BS EN 60068-2-2
Bb/Be Dry Heat+70°C

VIBRATION

BS EN 60068-2-6
Ten sweeps in each of three major axes
5 Hz to 8 Hz @ +/-7.5 mm, 8 Hz to 500 Hz @ 2 gn

SHOCK

BS EN 60068-2-27
Three shocks in each of three major axes 15 gn in 11 Ms

HUMIDITY

BS EN 60068-2-30
Db Damp Heat Cyclic 20/55 °C @ 95% RH 48 Hours
BS EN 60068-2-78
Cab Damp Heat Static 40 °C @ 93% RH 48 Hours

SPECIFICATION

CONTINUOUS VOLTAGE RATING

8 V to 35 V Continuous

CRANKING DROPOUTS

Able to survive 0 V for 50 mS, providing supply was at least 10 V before dropout and supply recovers to 5 V. This is achieved without the need for internal batteries. LEDs and backlight will not be maintained during cranking.

MAXIMUM OPERATING CURRENT

325 mA at 12 V, 152 mA at 24 V

MAXIMUM STANDBY CURRENT

70 mA at 12 V, 32 mA at 24 V

AUXILIARY RELAY CONTACTS

2 Amp DC rated voltage free

DIMENSIONS OVERALL

165 mm x 76 mm x 49 mm
6.5" x 3" x 1.9"

This page intentionally left blank



Image shown might not reflect actual configuration

Remote Annunciator Module

It is an LED expansion module that can be used with compatible control modules. The module has been designed to display a maximum of eight individual LED indications up to a maximum distance of 1 KM (0.6miles).

The Annunciator will consist of two modules to provide a 16 Channel Fault annunciation.

It is presented in a vertical enclosure. It includes an alarm sounder that is triggered when the host controller detects an alarm condition. The alarm can be muted using the front push button.

The Panels will be fitted with removable label cards which can be used to identify the standard NFPA alarms. If desired

It includes individual LEDs for each channel and a 'Power On' LED that flashes when the link with the host controller is lost.

FEATURES

- The Remote annunciator has an integral Sounder/Horn
- Eight configurable LEDs (per module)
- Works up to 1 KM (0.6 miles) from the host controller
- A single Controller can support five Caterpillar Configured remote annunciator control boxes

LEHE2021-01 (03-21)

www.Cat.com/electricpower

©2021 Caterpillar All rights reserved. Materials and specifications are subject to change without notice. The International System of Units (SI) is used in this publication. CAT, CATERPILLAR, their respective logos, "Caterpillar Corporate Yellow", the "Power Edge" and Cat "Modern Hex" trade dress as well as corporate and product identity used herein, are trademarks of Caterpillar and may not be used without permission.

ENVIRONMENTAL TESTING STANDARDS

ELECTRO-MAGNETIC COMPATIBILITY

BS EN 61000-6-2
EMC Generic Immunity Standard for the Industrial Environment
BS EN 61000-6-4
EMC Generic Emission Standard for the Industrial Environment

ELECTRICAL SAFETY

BS EN 60950
Safety of Information Technology Equipment, including Electrical Business Equipment

TEMPERATURE

BS EN 60068-2-1
Ab/Ae Cold Test -30 °C BS EN 60068-2-2
Bb/Be Dry Heat+70°C

VIBRATION

BS EN 60068-2-6
Ten sweeps in each of three major axes
5 Hz to 8 Hz @ +/-7.5 mm, 8 Hz to 500 Hz @ 2 gn

SHOCK

BS EN 60068-2-27
Three shocks in each of three major axes 15 gn in 11 Ms

HUMIDITY

BS EN 60068-2-30
Db Damp Heat Cyclic 20/55 °C @ 95% RH 48 Hours
BS EN 60068-2-78
Cab Damp Heat Static 40 °C @ 93% RH 48 Hours

DEGREES OF PROTECTION PROVIDED BY ENCLOSURES BS EN 60529

IP65 - Front of module when installed into the control panel with the supplied sealing gasket.

SPECIFICATION

CONTINUOUS VOLTAGE RATING

8 V to 35 V Continuous

CRANKING DROPOUTS

Able to survive 0 V for 50 mS, providing supply was at least 10 V before dropout and supply recovers to 5 V. This is achieved without the need for internal batteries. LEDs and backlight will not be maintained during cranking.

MAXIMUM OPERATING CURRENT

112 mA at 12 V, 53 mA at 24 V

MAXIMUM STANDBY CURRENT

74 mA at 12 V, 35 mA at 24 V

DIMENSIONS OVERALL

355 mm x 369 mm x 90 mm
13.97" x 14.52" x 3.54"

PANEL CUT-OUT

286 mm x 326 mm x 93 mm
11.25" x 12.83" x 3.66"

MAXIMUM PANEL THICKNESS

8 mm
0.3"

This page intentionally left blank



Image shown might not reflect actual configuration

Remote Annunciator Module

It is an LED expansion module that can be used with compatible control modules. The module has been designed to display a maximum of eight individual LED indications up to a maximum distance of 1 KM (0.6miles).

The Annunciator will consist of two modules to provide a 16 Channel Fault annunciation.

It is presented in a vertical enclosure. It includes an alarm sounder that is triggered when the host controller detects an alarm condition. The alarm can be muted using the front push button.

The Panels will be fitted with removable label cards which can be used to identify the standard NFPA alarms. If desired

It includes individual LEDs for each channel and a 'Power On' LED that flashes when the link with the host controller is lost.

FEATURES

- The Remote annunciator has an integral Sounder/Horn
- Eight configurable LEDs (per module)
- Works up to 1 KM (0.6 miles) from the host controller
- A single Controller can support five Caterpillar Configured remote annunciator control boxes

LEHE2021-01 (03-21)

www.Cat.com/electricpower

©2021 Caterpillar All rights reserved. Materials and specifications are subject to change without notice. The International System of Units (SI) is used in this publication. CAT, CATERPILLAR, their respective logos, "Caterpillar Corporate Yellow", the "Power Edge" and Cat "Modern Hex" trade dress as well as corporate and product identity used herein, are trademarks of Caterpillar and may not be used without permission.

ENVIRONMENTAL TESTING STANDARDS

ELECTRO-MAGNETIC COMPATIBILITY

BS EN 61000-6-2
EMC Generic Immunity Standard for the Industrial Environment
BS EN 61000-6-4
EMC Generic Emission Standard for the Industrial Environment

ELECTRICAL SAFETY

BS EN 60950
Safety of Information Technology Equipment, including Electrical Business Equipment

TEMPERATURE

BS EN 60068-2-1
Ab/Ae Cold Test -30 °C BS EN 60068-2-2
Bb/Be Dry Heat+70°C

VIBRATION

BS EN 60068-2-6
Ten sweeps in each of three major axes
5 Hz to 8 Hz @ +/-7.5 mm, 8 Hz to 500 Hz @ 2 gn

SHOCK

BS EN 60068-2-27
Three shocks in each of three major axes 15 gn in 11 Ms

HUMIDITY

BS EN 60068-2-30
Db Damp Heat Cyclic 20/55 °C @ 95% RH 48 Hours
BS EN 60068-2-78
Cab Damp Heat Static 40 °C @ 93% RH 48 Hours

DEGREES OF PROTECTION PROVIDED BY ENCLOSURES BS EN 60529

IP65 - Front of module when installed into the control panel with the supplied sealing gasket.

SPECIFICATION

CONTINUOUS VOLTAGE RATING

8 V to 35 V Continuous

CRANKING DROPOUTS

Able to survive 0 V for 50 mS, providing supply was at least 10 V before dropout and supply recovers to 5 V. This is achieved without the need for internal batteries. LEDs and backlight will not be maintained during cranking.

MAXIMUM OPERATING CURRENT

112 mA at 12 V, 53 mA at 24 V

MAXIMUM STANDBY CURRENT

74 mA at 12 V, 35 mA at 24 V

DIMENSIONS OVERALL

355 mm x 369 mm x 90 mm
13.97" x 14.52" x 3.54"

PANEL CUT-OUT

286 mm x 326 mm x 93 mm
11.25" x 12.83" x 3.66"

MAXIMUM PANEL THICKNESS

8 mm
0.3"

This page intentionally left blank

CUSTOMER INTERCONNECT WIRING
EMCP 4 W/ REMOTE ANNUCIATOR

REMOTE ANNUCIATOR

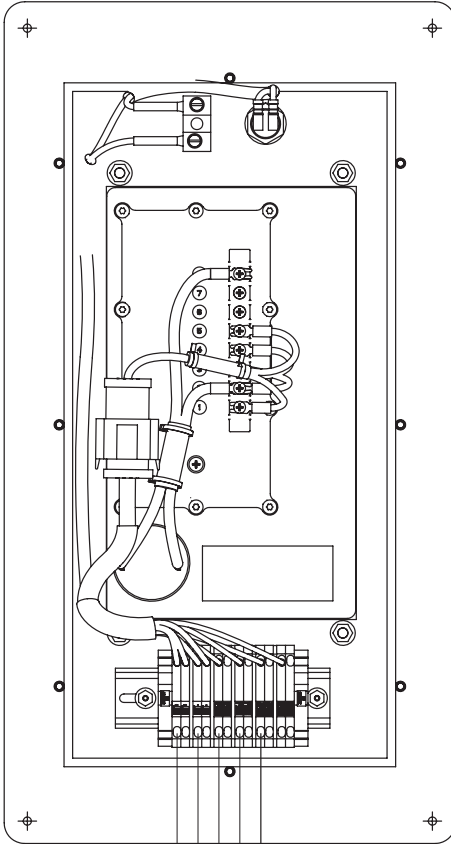

GENSET TERMINAL STRIP

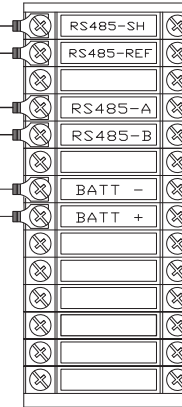

RS485 CABLE

(2) # 12 AWG (24 VDC)

REVISION HISTORY		
REV	BY	DATE
04	_____	_____
03	_____	_____
02	_____	_____
01	CSM	17FEB14
00	JJR	14MAR12

EMCP 4 Connection to Remote Annunciator

ALL DIMENSIONS IN CM [INCHES] DRAWN BY: J. Rose

NOT TO SCALE CHECKED: J. Rose

DATE: 14 March 2012 APPROVED: _____

DWG No. SHEET 1 OF 1

_____CUSTOMER WIRING



Product: [8770](#)

Electronic, 3 C #18 Str TC, PO Ins, OS, PVC Jkt, CM

[Request Sample](#)

Product Description

Electronic, 3 Conductor 18AWG (16x30) Tinned Copper, PO Insulation, Overall Beldfoil® Shield, PVC Outer Jacket, CM

Technical Specifications

Physical Characteristics (Overall)

Conductor

AWG	Stranding	Material	No. of Conductors
18	16x30	TC - Tinned Copper	3

Conductor Count: 3

Insulation

Material	Nominal Wall Thickness
PE - Polyethylene	0.018 in

Color Chart

Number	Color
1	Black
2	Red
3	Clear

Outer Shield Material

Type	Material	Material Trade Name	Coverage [%]	Drainwire Material	Drainwire AWG	Drainwire Construction n x D
Tape	Aluminum/Polyester	Beldfoil® with shorting fold	100 %	TC - Tinned Copper	20	Stranded mm

Outer Jacket Material

Material	Nominal Diameter	Nominal Wall Thickness
PVC - Polyvinyl Chloride	0.246 in	0.033 in

Construction and Dimensions

Cabling

Lay Direction	Twists
Left Hand	4.4 twist/ft

Electrical Characteristics

Conductor DCR

Nominal Conductor DCR	Nominal Outer Shield DCR
6.6 Ohm/1000ft	8.5 Ohm/1000ft

Capacitance

Nom. Capacitance Conductor to Conductor	Nom. Capacitance Conductor to Other Conductor to Shield
24 pF/ft	48 pF/ft

Inductance

Nominal Inductance

0.18 µH/ft

Impedance

Nominal Characteristic Impedance

69 Ohm

Current

Element	Max. Recommended Current [A]
10C temperature rise	5.3 Amps per conductor @ 25°C ambient

Voltage

UL Voltage Rating

300 V RMS

Temperature Range

UL Temp Rating:	60°C (UL AWM Style 2093)
Operating Temp Range:	-20°C To +60°C

Mechanical Characteristics

Bulk Cable Weight:	36 lbs/1000ft
Max Recommended Pulling Tension:	74 lbs
Min Bend Radius/Minor Axis:	2.5 in

Standards

NEC Articles:	800
NEC/(UL) Specification:	CM
CEC/C(UL) Specification:	CM
UL AWM Style:	UL Style 2093 (300 V 60°C)
CPR Euroclass:	Eca

Applicable Environmental and Other Programs

EU Directive 2000/53/EC (ELV):	Yes
EU Directive 2003/96/EC (BFR):	Yes
EU Directive 2011/65/EU (ROHS II):	Yes
EU Directive 2012/19/EU (WEEE):	Yes
EU Directive 2015/863/EU:	Yes
EU Directive Compliance:	EU Directive 2003/11/EC (BFR)
EU CE Mark:	Yes
EU RoHS Compliance Date (yyyy-mm-dd):	2004-01-01
CA Prop 65 (CJ for Wire & Cable):	Yes
MII Order #39 (China RoHS):	Yes

Suitability

Suitability - Indoor:	Yes
-----------------------	-----

Flammability, LSOH, Toxicity Testing

UL Flammability:	UL1685 UL Loading
CSA Flammability:	FT1
ISO/IEC Flammability:	IEC 60332-1-2
UL voltage rating:	300 V RMS

Plenum/Non-Plenum

Plenum (Y/N):	No
Plenum Number:	88770

Part Number

Variants

Item #	Color	UPC	Length	Footnote
8770.023048	Black		3,048 m	

8770.00U152	Chrome		152 m	
8770.00U305	Chrome		305 m	
8770.01152	Chrome		152 m	
8770.013048	Chrome		3,048 m	
8770.01305	Chrome		305 m	
8770 0601000	Chrome	612825215608	1,000 ft	C
8770 06010000	Chrome	612825215615	10,000 ft	C Y
8770 06012000	Chrome	612825215646	12,000 ft	C Y
8770 060500	Chrome	612825215653	500 ft	C
8770 0605000	Chrome	612825215660	5,000 ft	
8770 060U1000	Chrome	612825215585	1,000 ft	
8770 060U500	Chrome	612825215592	500 ft	
8770.K1305	Chrome		305 m	

Footnote:	C - CRATE REEL PUT-UP.
Footnote:	Y - FINAL PUT-UP LENGTH MAY VAR -10% TO +20% FROM LENGTH SHOWN. MAY CONTAIN 2 PIECES. MINIMUM LENGTH OF ANY ONE PIECE IS 1500'.

History

Update and Revision:	Revision Number: 0.297 Revision Date: 12-19-2019
----------------------	--

© 2020 Belden, Inc

All Rights Reserved.

Although Belden makes every reasonable effort to ensure their accuracy at the time of this publication, information and specifications described here in are subject to error or omission and to change without notice, and the listing of such information and specifications does not ensure product availability.

Belden provides the information and specifications herein on an "ASIS" basis, with no representations or warranties, whether express, statutory or implied. In no event will Belden be liable for any damages (including consequential, indirect, incidental, special, punitive, or exemplary damages) whatsoever, even if Belden has been advised of the possibility of such damages, whether in an action under contract, negligence or any other theory, arising out of or in connection with the use, or inability to use, the information or specifications described herein.

All sales of Belden products are subject to Belden's standard terms and conditions of sale.

Belden believes this product to be in compliance with all applicable environmental programs as listed in the data sheet. The information provided is correct to the best of Belden's knowledge, information and belief at the date of its publication. This information is designed only as a general guide for the safe handling, storage, and any other operation of the product itself or the one that it becomes a part of. The Product Disclosure is not to be considered a warranty or quality specification. Regulatory information is for guidance purposes only. Product users are responsible for determining the applicability of legislation and regulations based on their individual usage of the product.

This page intentionally left blank

Cat[®] Batteries



Cat[®] Batteries—Greater Starting Power— Lower Maintenance—Longer Life

Cat Premium High Output (PHO) batteries are used in all Cat Machines and Engine Gen-Sets. They are designed to meet stringent Caterpillar design specifications, which provide industry leading cold cranking amps (CCA) capability and maximum vibration resistance.

Maintenance Free Accessible or low maintenance designs are available in wet and dry configurations.

General Service Line batteries are available in Maintenance Free Accessible or low maintenance designs. Wide selections of BCI group sizes are available for automotive, light truck, bus, industrial, agricultural, marine, recreational and valve regulated (VRLA-AGM & Gel) applications.



Cat® General Service Batteries—Available Worldwide



Quality Batteries for a Wide Range of Applications

Ideal for Automotive, Light Truck, Bus, Marine, Industrial, Agricultural, Stationary Power and Recreational Usage.

- Maintenance Free Accessible and low maintenance... accessible or sealed
- Deep Cycle and Valve Regulated (VRLA) Gelled or Absorbed Glass Mat (AGM) batteries
- Hefty full frame grids, no sharp edges. Optimum acid/paste combination provides better charge acceptance after deep discharge
- Commercial batteries have Anchor Lock elements for vibration resistance
- Flame Arrestor Safety Vents to direct corrosive gases away from the battery and hold-downs

Wet Batteries

BCI Group Size	Part No.	CCA ≈	RC Mins †	Volts	Amp Hr. Capacity @ 20 Hrs.	Construction Notes	BCI Overall Dimensions			Nominal Weight
							Length In (mm)	Width In (mm)	Height In (mm)	Wet Lb (kg)
Truck/Agricultural/Industrial										
1	8C-3617	640	130	6	100	C/MF	9.0 (229)	6.9 (175)	8.8 (222)	30 (13.6)
2	8C-3629	780	200	6	90	LA	10.4 (264)	6.9 (175)	8.8 (222)	36.5 (16.6)
3EE	8C-3620	400	95	12	54	LA	19.3 (489)	4.3 (108)	9.0 (229)	42 (19.1)
3EH	8C-3632	875	250	6	115	LA	19.3 (489)	4.3 (108)	10.0 (254)	47.5 (21.5)
4	8C-3633	975	250	6	125	C/MF	12.5 (318)	6.9 (175)	9.5 (241)	47 (21.3)
4DLT	8C-3622	850	240	12	100	LA	20.0 (508)	8.1 (206)	8.1 (206)	80 (36.3)
8D	8C-3624	1400	430	12	190	LA	20.8 (527)	11.0 (279)	10.0 (254)	130 (59.0)
24F	3T-5858	675	115	12	55	C/MF	10.8 (273)	6.8 (171)	9.0 (229)	40 (18.1)
27	8C-3601	710	120	12	65	C/MF	12.0 (305)	6.8 (171)	9.0 (229)	45.5 (20.6)
27F	8C-3602	710	120	12	65	C/MF	12.4 (314)	6.8 (171)	9.0 (229)	45.5 (20.6)
31	8C-3628	760	170	12	80	C/MF/S	13.0 (330)	6.8 (171)	9.5 (241)	54.5 (24.7)
31	430-5996	1000	190	12	100	C/MF	13.0 (330)	6.8 (171)	9.5 (241)	58 (26.3)
C11(DIN)	369-9955	270	43	12	30	C	7.36 (187)	5.04 (128)	6.50 (165)	17.86 (8.1)
T4(DIN)	356-6211	380	66	12	44	C	8.27 (210)	6.89 (175)	6.89 (175)	16.09 (7.3)

Bus - Special Terminal

8D	250-0473	1400	430	12	190	C/MFA/TB	20.8 (527)	11.0 (279)	10.0 (254)	130 (59.0)
----	----------	------	-----	----	-----	----------	------------	------------	------------	------------

Automotive/Light Truck & SUV

22F	3T-5859	425	65	12	35	C/MF	9.4 (238)	6.8 (171)	8.3 (210)	29.5 (13.4)
24	3T-5857	675	115	12	55	C/MF	10.8 (273)	6.8 (171)	9.0 (229)	40 (18.1)
25	250-0488	625	95	12	45	C/MF	9.8 (248)	6.9 (175)	8.9 (225)	35.5 (16.1)
26	8C-3600	540	80	12	45	C/MF	8.8 (222)	6.8 (171)	8.0 (203)	29.5 (13.4)
26R	369-9958	540	80	12	45	C/MF	8.8 (222)	6.8 (171)	8.0 (203)	29.5 (13.4)
34/78	250-0486	690	110	12	60	C/MF/DT	10.8 (273)	6.8 (171)	8.0 (203) !	36.5 (16.6)
35	250-0487	625	95	12	45	C/MF	9.8 (248)	6.9 (175)	8.9 (225)	35.5 (16.1)
41	8C-3605	650	100	12	64	C/MF	11.6 (293)	6.9 (175)	6.9 (175)	38 (17.2)
42	250-0490	475	70	12	40	C/MF	9.6 (242)	6.9 (175)	6.9 (175)	29 (13.2)
48	430-5993	730	120	12	65	C/MF	11.0 (278)	6.9 (175)	7.5 (190)	42 (19.1)
49	307-0751	900	185	12	100	C/MF	14.0 (354)	6.9 (175)	7.5 (190)	54.5 (24.7)
55/56/62	8C-3611	570	90	12	52	C/MF/DT	8.8 (222)	6.0 (152)	8.50 (216)	32 (14.5)
58	8C-3612	580	85	12	53	C/MF	10.0 (254)	7.3 (184)	7.0 (178)	31.5 (14.3)
65	250-0484	675	130	12	55	C/MF	12.0 (305)	7.4 (187)	7.7 (194)	41 (18.6)
75	7X-6100	690	90	12	60	C/MF *	9.8 (248)	7.0 (178)	7.3 (184)	34.5 (15.6)
75/86	250-0489	540	85	12	47	C/MF/DT	9.8 (248)	7.0 (178)	8.1 (206) !	32 (14.5)
78	369-9957	690	110	12	58	C	10.8 (273)	6.9 (175)	7.3 (184)	36.5 (16.6)
90	430-6000	600	90	12	40	C/MF	9.5 (242)	6.9 (175)	6.9 (175)	32.5 (14.7)
91	430-6001	700	100	12	50	C/MF	11.0 (278)	6.9 (175)	6.9 (175)	38.5 (17.5)
92	430-6002	650	130	12	70	C/MF	12.5 (317)	6.9 (175)	6.9 (175)	37 (16.8)
93	430-6003	800	130	12	80	C/MF	14.0 (354)	6.9 (175)	6.9 (175)	46.5 (21.1)
94R	430-6005	765	135	12	80	C/MF	12.4 (315)	6.9 (175)	7.5 (190)	47.5 (21.6)
95R	430-6006	850	190	12	100	C/MF	15.5 (394)	6.9 (175)	7.5 (190)	62.5 (28.4)
96R	430-6007	600	90	12	40	C/MF	9.6 (242)	6.9 (175)	6.9 (175)	32.5 (14.8)
97R	430-6008	600	95	12	60	C/MF	9.6 (242)	6.9 (175)	7.5 (190)	37.5 (17.0)
101	430-6009	650	110	12	-	C/MF/ *	10.3 (260)	7.1 (179)	6.7 (170)	36 (16.3)
121R	430-6010	540	80	12	50	C/MF	8.3 (210)	7.0 (177)	8.1 (206)	30 (13.6)
124R	430-6011	670	100	12	60	C/MF	10.3 (260)	6.9 (175)	8.4 (212)	38 (17.2)
151R	430-6012	335	55	12	-	C/MF	7.24 (184)	5.0 (125)	8.8 (222)	19 (8.6)

Construction Notes:

Batteries use SAE taper post design and are shipped wet except as:

- LA = Low Maintenance - Low Antimony Grids
- LAC = Low Maintenance - Hybrid Construction
- C = Calcium Lead Alloy Grid Design
- MF = Maintenance Free Non-Accessible
- MFA = Maintenance Free Accessible
- S = Stud Terminals
- DT = Dual Terminal
- TB = Transit Bus one piece end terminal. Right end of battery. Positive Stud: 1/2"-13 steel, Negative Stud: 3/8" -16 steel
- OP = Offset Post with Horizontal Hole Stainless Steel 5/16" Bolt & Hex Nut
- * = Side Terminals
- ≈ = Cold Cranking Amps for 30 seconds at 0° F (-18° C)
- † = Reserve Capacity Minutes minimum of 25 amp output at 80° F (27° C)
- ! = For height with removable adapter, add 7/8" (22mm)
- @ = Deep Cycle - Antimony Grids
- ~ = Marine Starting
- + = Shipped Dry Only
- \$ = 75 amps @ 80° F
- # = Wing nut for 8C-3638 & 8C-3639 is part number 3B-0723

BCI Terminal Locations

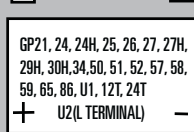
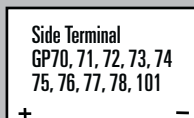
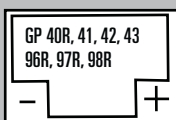
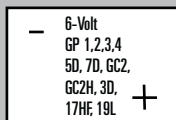
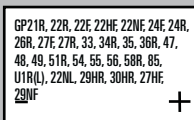
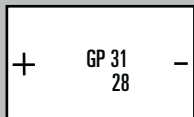
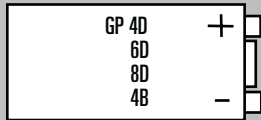
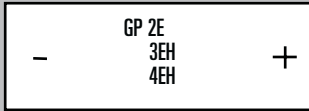

Transit Bus Terminal for 8D Part # 250-0473
 One piece end terminal.
 Right end of Battery.
 1/2" - 13 Steel Positive Stud
 3/8" - 16 Steel Negative Stud
 Terminal not serviceable

Type B

Cat Premium High Output Batteries — Built Tough to Exceed Demanding Performance Test Requirements:

- 100 hour Vibration Testing – Five Times the Industry Standard**
 Battery must be able to withstand vibration forces without suffering mechanical damage, loss of capacity, loss of electrolyte or without developing internal/external leaks
 Battery must pass a high rate discharge test after the vibration testing
- Five 72-hour Deep Discharge/Recharge Test Cycles**
 Battery must recover to 25 charging amps within 20 minutes and meet Industry Electrical Performance Standards
- 30 Day Complete Discharge Test**
 Battery must recover to 25 charging amps within 60 minutes and meet Industry Electrical Performance Standards after recharging
- SAE J2185 Life Cycle Test**
 Battery subject to deeper discharge and charge cycles at extreme temperatures not normally encountered in starting a machine or vehicle
- Cold Soak Test**
 Battery cold soaked at sub-freezing temperatures and then tested by starting an equally cold engine



Battery Accessories

- Group 31 - Charging Posts for Stud Terminals - Part # 4C-5637
- Screw-in Charging Posts for Side Terminals - Part # 4C-5638
- Wing Nut - Part # 2B-9498 for Part #'s 175-4390/175-4370/175-4360/8C-3628
- Wing Nut - Part # 3B-0723 for Part #'s 8C-3638 and 8C-3639
- Booster Cable 12' (3.66 m) - Part # 4C-4911
- Booster Cable 20' (6.00 m) - Part # 4C-4933
- Heavy Duty Commercial Fast Charger (110V) - Part # 4C-4921
- Heavy Duty Commercial Fast Charger (220V) - Part # 4C-4910

Note: Ratings and Part Numbers are subject to change without notice.



Recycle all scrap batteries.
 We accept lead-acid batteries for recycling.

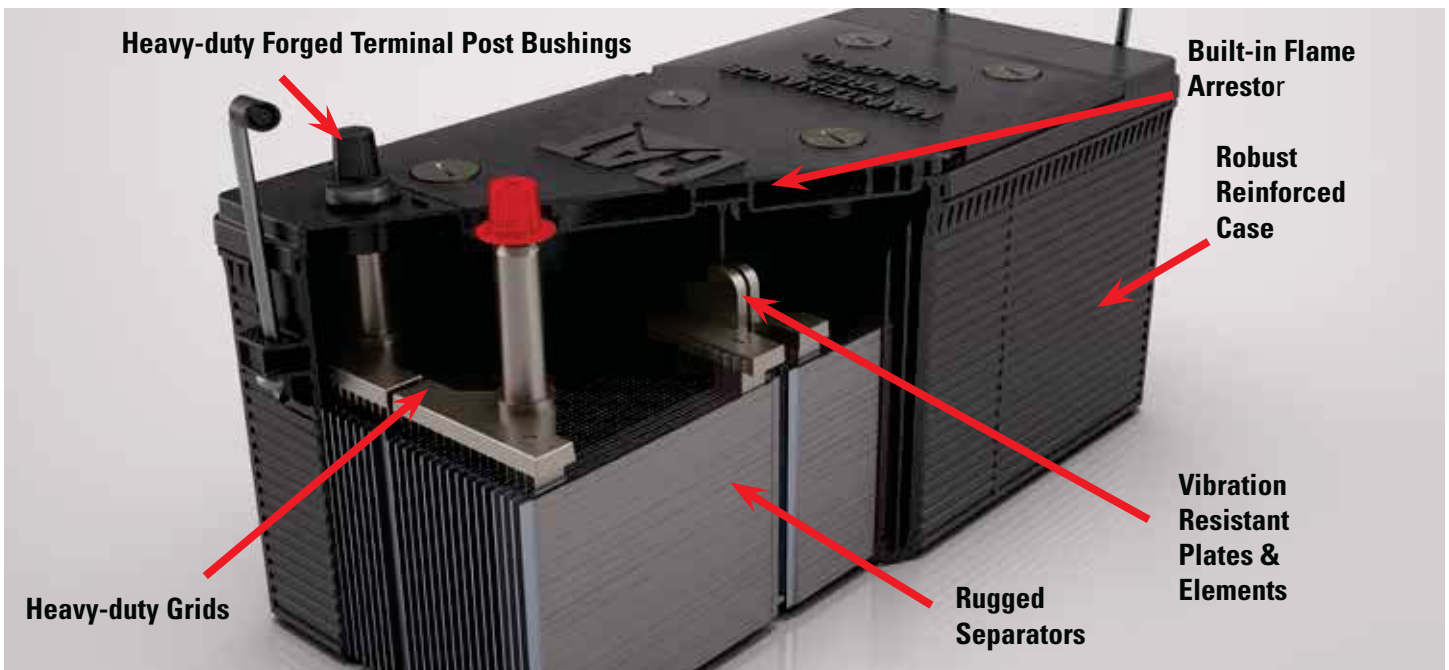

Robust Components = Long Life + Reliable Starts

- Heavy-duty forged terminal post bushings provide maximum strength and resistance to acid seepage that causes corrosion and black posts. Thicker internal terminal posts provide lower electrical resistance and higher cold cranking amp output.
- Rugged micro porous polyethylene envelope separators protect against “shorts” and vibration damage. Deep Cycle batteries utilize double insulated Glass mat separators for longer cycling life.
- Maintenance Free Accessible batteries utilize calcium lead alloy on both positive and negative plates that reduces gassing and water consumption. Automotive batteries have Silver (Ag) Calcium Alloy Grids for resistance to high underhood temperatures.
- Heavy-duty, full frame battery grids with no sharp edges. An optimum acid/paste combination provides better charge acceptance after a deep discharge.
- Positive and Negative plates are anchored to the container bottom and the cell element is locked at the top for maximum vibration resistance. Straps are thicker, heavier and cast (not welded) into the plates.
- Manifold vented cover with built-in Flame Arrestor... a safety feature that directs corrosive gases away from the battery and hold-downs.
- Robust reinforced case provides extra strength in all temperature extremes. Brickwork design on sides reduces chance of punctures and case flexing. Embossed part number and descriptors for easy serviceability.

CAT DEALERS DEFINE WORLD-CLASS PRODUCT SUPPORT.

We offer you the right parts and service solutions, when and where you need them.

The Cat Dealer network of highly trained experts keeps your entire fleet up and running to maximize your equipment investment.



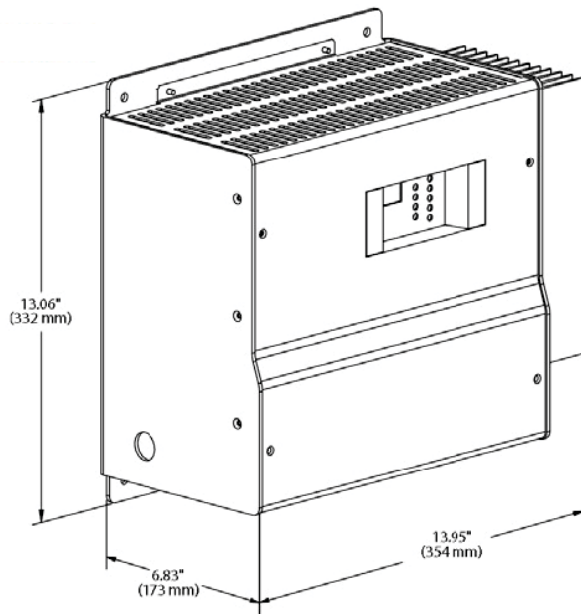

UL 20 Amp Battery Charger

This battery charger offers accurate, automatic charging of lead-acid and nickel cadmium batteries. The output voltage automatically adjusts to changing input, load, battery and ambient conditions. This prevents battery over-charging and consequent loss of battery electrolyte.

Standard features include AC line compensation, precision voltage regulation, current limiting, automatic 2-rate charging, voltmeter and ammeter, temperature compensation and UL Listing.

The user interface is easy to understand with digital metering, NFPA 110 alarms and a battery fault alarm.

Features

- Electronically current limited at 105% of rated output
- Alarm system
- Digital Display
- Lightning and voltage transient protection
- Protection of connected equipment against load dump
- Constant voltage, current limited, 4-rate automatic equalization
- IP 20 housing
- Temperature Compensation
 - On board temperature sensor with remote port
- AC isolated from DC
- Auto AC line compensation
- Output regulated by sensed battery voltage

Dimensions			
Width	Depth	Height	Weight
354 mm (13.93 in)	173 mm (6.83 in)	332 mm (13.06 in)	19.1 kg (42 lb)

Specification

Input supply	110 – 120 V 208 – 240V
AC and DC fuses	(2 input and 2 output)
Output voltage	24V
Output amps	20A
Input Frequency	50 / 60 Hz
Operating temperature	-20°C (-4°F) to +60°C (140°F)

Housing constructed of rustproof anodized aluminum.

Standards

- C-UL listed to UL 1236
- NFPA 70, NFPA 110
- CSA 22.2 No 107 certified
- UL 1564
- CE DOC to EN 60335
- IBC Seismic Certification

Feature code: BTC 20A2

NFPA 110 alarm package as follows:

- AC on Green led (indication)
- AC fail Red led and form C contact (2A)
- Float mode LED
- Fast charge LED
- Temp comp active LED
- Low battery volts Red LED and Form C contact
- High battery volts Red LED and Form C contact
- Charger fail Red LED and Form C contact
- Battery fault Red LED and Form C contact
 - Battery disconnected
 - Battery polarity reversed
 - Mismatched charger battery voltage
 - Open or high resistance charger to battery connection
 - Open battery cell or excessive internal resistance

Information contained in this publication may be considered confidential. Discretion is recommended when distributing.
Materials and specifications are subject to change without notice.

CAT, CATERPILLAR, LET'S DO THE WORK, their respective logos, "Caterpillar Yellow," the "Power Edge" and Cat "Modern Hex" trade dress as well as corporate and product identity used herein, are trademarks of Caterpillar and may not be used without permission.

Jacket Water Heater with Pump Diesel Gensets: C27, C32

Caterpillar offers a factory installed Jacket Water Heater for improved Engine Cold-Starting capability

This Jacket Water Heater is a Thermostatically controlled Heater with an integrated pump, built in bleed screw and High Limit Thermostat that can be manually reset

Forced circulation of the coolant delivers uniform heating throughout the entire engine, reduces wear from Cold spots and offers significant reduction of Electrical consumption

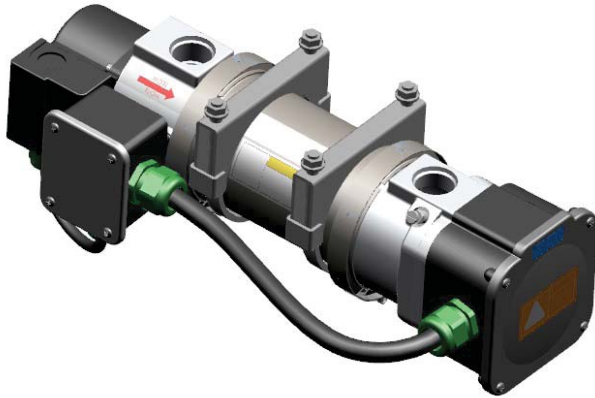

Features

Factory Installed

- Complete with Hoses, Thermostat (Control and Hi-Limit) and Pump
- Base Frame mounting minimizes Engine induced vibration
- Temperature Controlled Pump operation
- Supplied with UL, C (UL) US and CE recognized components
- Control Thermostat is Factory preset to 49°C (120°F)

Heater Design Description

- Jacket Water Heater Package is designed to efficiently preheat the engine by circulating the heated coolant onto engine
- This design results in following benefits
- Increase life of Heater Hoses, Engine Seals and Heating Elements
- Improves Heat Transfer efficiency from Elements to Engine Coolant
- Uniform Engine temperature distribution
- Application of Thermostat with a reduced thermal differential
- Lower Customer utility costs and increased Heater reliability
- Heater's Control Thermostat set point is preset

Heater Operation

A 34 L/pm (9 GPM) Pump is located at the Heater Inlet to push the coolant through the Heater
A Control Thermostat is located inside a Plastic Enclosure near the Inlet of Heater and responds to the temperature of coolant entering the tank
A High Limit Thermostat is located inside a Plastic Element Enclosure near the Outlet of Heater opens and cuts off supply to Heating Element, if tank attains 96°C (205°F). This Thermostat can be manual reset to close position.

Temperature Controlled Pump Operation – Pump runs only with Heating Elements.

Air release valve (Bleed Screw) provided to allow vent air from Heater, prior to energizing the Heater.

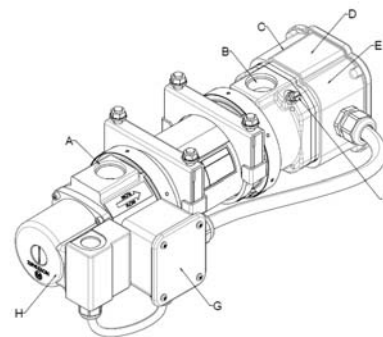

- | | |
|---|---|
| A. Suction Port
(SAE Dash 16) | E. High-limit Thermostat
with manual reset (in
Element assembly) |
| B. Discharge Port
(SAE Dash 16) | F. Air Release Valve |
| C. Power in Wiring Entrance | G. Control Thermostat
(in enclosure) |
| D. Element Assembly | H. Pump/Motor |

Specifications

	Voltage	
	240	220
Heater Power	6kW	6kW
Frequency	60	50
Phase	Single	Single
Amps	25A	26A
Flow Rate	34 L/pm (9 GPM)	
Pump Rating	230 VAC 97W	230 VAC 70W
Control Thermostat (Set Point)	38°C – 49°C (100°F – 120°F)	
High Limit Thermostat (Set Point)	96°C (205°F), Manual Reset	
Length	466 mm (18.3")	
Width	216 mm (8.5")	
Height	183 mm (7.2")	
Weight	6.5 Kg	

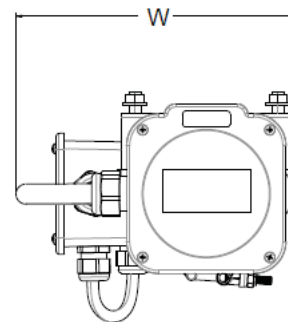
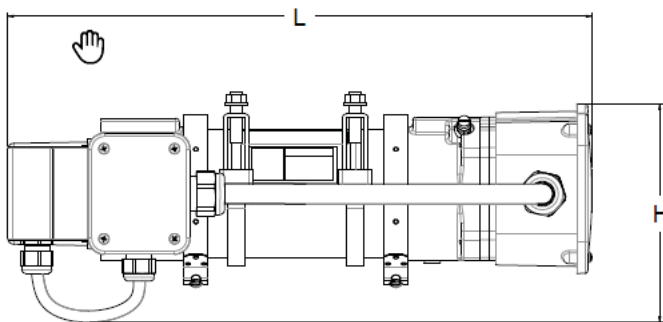

Wiring Diagram

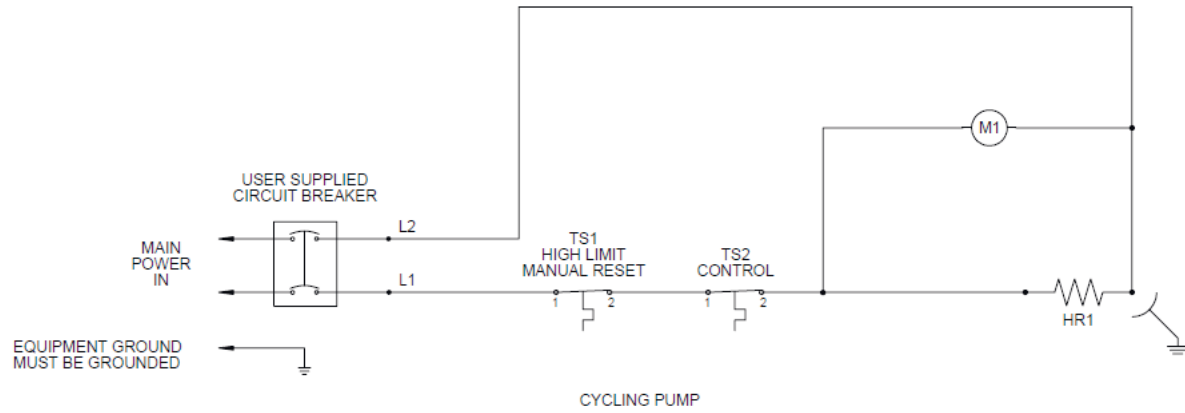

Materials and specifications are subject to change without notice. The International System of Units (SI) is used in this publication.
© 2021 Caterpillar. All Rights Reserved. CAT, CATERPILLAR, LET'S DO THE WORK, their respective logos, "Caterpillar Corporate Yellow", the "Power Edge" and Cat "Modern Hex" trade dress as well as corporate and product identity used herein, are trademarks of Caterpillar and may not be used without permission

www.cat.com/electricpower
©2021 Caterpillar
All rights reserved.

This page intentionally left blank

Effective with sales to the first user on or after August 1, 2018

CATERPILLAR LIMITED WARRANTY

Industrial, Petroleum, Locomotive, and Agriculture Engine Products and Electric Power Generation Products

Worldwide

Caterpillar Inc. or any of its subsidiaries ("Caterpillar") warrants new and remanufactured engines and new and rebuild electric power generation products sold by it (including any products of other manufacturers packaged and sold by Caterpillar), to be free from defects in material and workmanship.

This warranty does not apply engines sold for use in on-highway vehicle or marine applications; engines in machines manufactured by or for Caterpillar; C175, 3500 and 3600 series engines used in locomotive applications; 3000 Family engines, C0.5 through C4.4 and ACERT™ (C6.6, C7, C7.1, C9, C9.3, C11, C13, C15, C18, C27, and C32) engines used in industrial, mobile agriculture and locomotive applications; or Cat[®] batteries; or Electric Power Generation Products manufactured or assembled in India. These products are covered by other Caterpillar warranties.

This warranty is subject to the following:

Warranty Period

- For industrial engines, engines in a petroleum applications or Petroleum Power Systems (excluding petroleum fire pump application), or engines in a Locomotive application, or Uninterruptible Power Supply (UPS) systems, the warranty period is 12 months after date of delivery to the first user.
- For engines used in petroleum fire pump and mobile agriculture applications the warranty period is 24 months after date of delivery to the first user.
- For controls only (EPIC), configurable and custom switchgear products, and automatic transfer switch products, the warranty period is 24 months after date of delivery to the first user.
- For new CG132, CG170 and CG260 series power generation products the warranty period is 24 months after date of delivery to first user, but not to exceed 36 months from shipment from the Caterpillar place of manufacture.
- For electric power generation products other than CG132, CG170 and CG260 series in prime or continuous applications the warranty period is 12 months. For standby applications the warranty period is 24 months/1000 hours. For emergency standby applications the warranty period is 24 months/400 hours. All terms begin after date of delivery to the first user.
- For Caterpillar rebuild electric power generation products the warranty period is 12 months, but not to exceed 24 months from shipment of rebuilt electric power generation product from Caterpillar.
- For all other applications the warranty period is 12 months after date of delivery to the first user.

Caterpillar Responsibilities

If a defect in material or workmanship is found during the warranty period, Caterpillar will, during normal working hours and at a place of business of a Cat dealer or other source approved by Caterpillar:

- Provide (at Caterpillar's choice) new, Remanufactured, or Caterpillar approved repaired parts or assembled components needed to correct the defect.

Note: New, remanufactured, or Caterpillar approved repaired parts or assembled components provided under the terms of this warranty are warranted for the remainder of the warranty period applicable to the product in which installed as if such parts were original components of that product. Items replaced under this warranty become the property of Caterpillar.

- Replace lubricating oil, filters, coolant, and other service items made unusable by the defect.
- Provide reasonable and customary labor needed to correct the defect, including labor to disconnect the product from and reconnect the product to its attached equipment, mounting, and support systems, if required.

For new 3114, 3116, and 3126 engines and, new and Caterpillar rebuild electric power generation products (which includes the following: any new products of other manufacturers packaged and sold by Caterpillar)

- Provide travel labor, up to four hours round trip, if in the opinion of Caterpillar, the product cannot reasonably be transported to a place of business of a Cat dealer or other source approved by Caterpillar (travel labor in excess of four hours round trip, and any meals, mileage, lodging, etc. is the user's responsibility).

For all other products:

- Provide reasonable travel expenses for authorized mechanics, including meals, mileage, and lodging, when Caterpillar chooses to make the repair on-site.

User Responsibilities

The user is responsible for:

- Providing proof of the delivery date to the first user.
- Labor costs, except as stated under "Caterpillar Responsibilities," including costs beyond those required to disconnect the product from and reconnect the product to its attached equipment, mounting, and support systems.
- Travel or transporting costs, except as stated under "Caterpillar Responsibilities."

- Premium or overtime labor costs.
- Parts shipping charges in excess of those that are usual and customary.
- Local taxes, if applicable.
- Costs to investigate complaints, unless the problem is caused by a defect in Caterpillar material or workmanship.
- Giving timely notice of a warrantable failure and promptly making the product available for repair.
- Performance of the required maintenance (including use of proper fuel, oil, lubricants, and coolant) and items replaced due to normal wear and tear.
- Allowing Caterpillar access to all electronically stored data.

Limitations

Caterpillar is not responsible for:

- Failures resulting from any use or installation that Caterpillar judges improper.
- Failures resulting from attachments, accessory items, and parts not sold or approved by Caterpillar.
- Failures resulting from abuse, neglect, and/or improper repair.
- Failures resulting from user's delay in making the product available after being notified of a potential product problem.
- Failures resulting from unauthorized repairs or adjustments, and unauthorized fuel setting changes.
- Damage to parts, fixtures, housings, attachments, and accessory items that are not part of the engine, Cat Selective Catalytic Reduction System or electric power generation product (including any products of other manufacturers packaged and sold by Caterpillar).
- Repair of components sold by Caterpillar that is warranted directly to the user by their respective manufacturer. Depending on type of application, certain exclusions may apply. Consult your Cat dealer for more information.

(Continued on reverse side...)

This warranty covers every major component of the products. Claims under this warranty should be submitted to a place of business of a Cat dealer or other source approved by Caterpillar. For further information concerning either the location to submit claims or Caterpillar as the issuer of this warranty, write Caterpillar Inc., 100 N. E. Adams St., Peoria, IL USA 61629.

Caterpillar's obligations under this Limited Warranty are subject to, and shall not apply in contravention of, the laws, rules, regulations, directives, ordinances, orders, or statutes of the United States, or of any other applicable jurisdiction, without recourse or liability with respect to Caterpillar.

A) For products operating outside of Australia, Fiji, Nauru, New Caledonia, New Zealand, Papua New Guinea, the Solomon Islands and Tahiti, the following is applicable:

NEITHER THE FOREGOING EXPRESS WARRANTY NOR ANY OTHER WARRANTY BY CATERPILLAR, EXPRESS OR IMPLIED, IS APPLICABLE TO ANY ITEM CATERPILLAR SELLS THAT IS WARRANTED DIRECTLY TO THE USER BY ITS MANUFACTURER.

THIS WARRANTY IS EXPRESSLY IN LIEU OF ANY OTHER WARRANTIES, EXPRESS OR IMPLIED, INCLUDING ANY WARRANTY OF MERCHANTABILITY OR FITNESS FOR A PARTICULAR PURPOSE, EXCEPT CATERPILLAR EMISSION-RELATED COMPONENTS WARRANTIES FOR NEW ENGINES, WHERE APPLICABLE. REMEDIES UNDER THIS WARRANTY ARE LIMITED TO THE PROVISION OF MATERIAL AND SERVICES, AS SPECIFIED HEREIN.

CATERPILLAR IS NOT RESPONSIBLE FOR INCIDENTAL OR CONSEQUENTIAL DAMAGES.

CATERPILLAR EXCLUDES ALL LIABILITY FOR OR ARISING FROM ANY NEGLIGENCE ON ITS PART OR ON THE PART OF ANY OF ITS EMPLOYEES, AGENTS OR REPRESENTATIVES IN RESPECT OF THE MANUFACTURE OR SUPPLY OF GOODS OR THE PROVISION OF SERVICES RELATING TO THE GOODS.

IF OTHERWISE APPLICABLE, THE VIENNA CONVENTION ON CONTRACTS FOR THE INTERNATIONAL SALE OF GOODS IS EXCLUDED IN ITS ENTIRETY.

For personal or family use engines or electric power generation products, operating in the USA, its territories and possessions, some states do not allow limitations on how long an implied warranty may last nor allow the exclusion or limitation of incidental or consequential damages. Therefore, the previously expressed exclusion may not apply to you. This warranty gives you specific legal rights and you may also have other rights, which vary by jurisdiction. To find the location of the nearest Cat dealer or other authorized repair facility, call (309) 675-1000. If you have questions concerning this warranty or its applications, call or write:

In USA and Canada: Caterpillar Inc, 100 N.E. Adams St., Peoria, IL USA 61629, Attention: Customer Service Manager, Telephone 1 (309) 675-1000, outside the USA and Canada: Contact your Cat dealer.

B) For products operating in Australia, Fiji, Nauru, New Caledonia, New Zealand, Papua New Guinea, the Solomon Islands and Tahiti, the following is applicable:

THIS WARRANTY IS IN ADDITION TO WARRANTIES AND CONDITIONS IMPLIED BY STATUTE AND OTHER STATUTORY RIGHTS AND OBLIGATIONS THAT BY ANY APPLICABLE LAW CANNOT BE EXCLUDED, RESTRICTED OR MODIFIED ("MANDATORY RIGHTS"). ALL OTHER WARRANTIES OR CONDITIONS, EXPRESS OR IMPLIED (BY STATUTE OR OTHERWISE), ARE EXCLUDED. WITHOUT LIMITING THE FOREGOING PROVISIONS OF THIS PARAGRAPH, WHERE A PRODUCT IS SUPPLIED FOR BUSINESS PURPOSES, THE CONSUMER GUARANTEES UNDER THE CONSUMER GUARANTEES ACT 1993 (NZ) WILL NOT APPLY.

NEITHER THIS WARRANTY NOR ANY OTHER CONDITION OR WARRANTY BY CATERPILLAR, EXPRESS OR IMPLIED (SUBJECT ONLY TO THE MANDATORY RIGHTS), IS APPLICABLE TO ANY ITEM CATERPILLAR SELLS THAT IS WARRANTED DIRECTLY TO THE USER BY ITS MANUFACTURER.

IF THE MANDATORY RIGHTS MAKE CATERPILLAR LIABLE IN CONNECTION WITH SERVICES OR GOODS, THEN TO THE EXTENT PERMITTED UNDER THE MANDATORY RIGHTS, THAT LIABILITY SHALL BE LIMITED AT CATERPILLAR'S OPTION TO (a) IN THE CASE OF SERVICES, THE SUPPLY OF THE SERVICES AGAIN OR THE PAYMENT OF THE COST OF HAVING THE SERVICES SUPPLIED AGAIN AND (b) IN THE CASE OF GOODS, THE REPAIR OR REPLACEMENT OF THE GOODS, THE SUPPLY OF EQUIVALENT GOODS, THE PAYMENT OF THE COST OF SUCH REPAIR OR REPLACEMENT OR THE ACQUISITION OF EQUIVALENT GOODS.

CATERPILLAR EXCLUDES ALL LIABILITY FOR OR ARISING FROM ANY NEGLIGENCE ON ITS PART OR ON THE PART OF ANY OF ITS EMPLOYEES, AGENTS OR REPRESENTATIVES IN RESPECT OF THE MANUFACTURE OR SUPPLY OF GOODS OR THE PROVISION OF SERVICES RELATING TO THE GOODS.

CATERPILLAR IS NOT LIABLE FOR INCIDENTAL OR CONSEQUENTIAL DAMAGES UNLESS IMPOSED UNDER MANDATORY RIGHTS.

IF OTHERWISE APPLICABLE, THE VIENNA CONVENTION ON CONTRACTS FOR THE INTERNATIONAL SALE OF GOODS IS EXCLUDED IN ITS ENTIRETY.

C) For products supplied in Australia:

IF THE PRODUCTS TO WHICH THIS WARRANTY APPLIES ARE:

I. PRODUCTS OF A KIND ORDINARILY ACQUIRED FOR PERSONAL, DOMESTIC OR HOUSEHOLD USE OR CONSUMPTION; OR

II. PRODUCTS THAT COST AUD 40,000 OR LESS,

WHERE THOSE PRODUCTS WERE NOT ACQUIRED FOR THE PURPOSE OF RE-SUPPLY OR FOR THE PURPOSE OF USING THEM UP OR TRANSFORMING THEM IN THE COURSE OF PRODUCTION OR MANUFACTURE OR IN THE COURSE OF REPAIRING OTHER GOODS OR FIXTURES, THEN THIS SECTION C APPLIES.

THE FOLLOWING MANDATORY TEXT IS INCLUDED PURSUANT TO THE AUSTRALIAN CONSUMER LAW AND INCLUDES REFERENCES TO RIGHTS THE USER MAY HAVE AGAINST THE DIRECT SUPPLIER OF THE PRODUCTS. OUR GOODS COME WITH GUARANTEES THAT CANNOT BE EXCLUDED UNDER THE AUSTRALIAN CONSUMER LAW. YOU ARE ENTITLED TO A REPLACEMENT OR REFUND FOR A MAJOR FAILURE AND COMPENSATION FOR ANY OTHER REASONABLY FORESEEABLE LOSS OR DAMAGE. YOU ARE ALSO ENTITLED TO HAVE THE GOODS REPAIRED OR REPLACED IF THE GOODS FAIL TO BE OF ACCEPTABLE QUALITY AND THE FAILURE DOES NOT AMOUNT TO A MAJOR FAILURE. THE INCLUSION OF THIS TEXT DOES NOT CONSTITUTE ANY REPRESENTATION OR ACCEPTANCE BY CATERPILLAR OF LIABILITY TO THE USER OR ANY OTHER PERSON IN ADDITION TO THAT WHICH CATERPILLAR MAY HAVE UNDER THE AUSTRALIAN CONSUMER LAW.

TO THE EXTENT THE PRODUCTS FALL WITHIN THIS SECTION C BUT ARE NOT OF A KIND ORDINARILY ACQUIRED FOR PERSONAL, DOMESTIC OR HOUSEHOLD USE OR CONSUMPTION, CATERPILLAR LIMITS ITS LIABILITY TO THE EXTENT IT IS PERMITTED TO DO SO UNDER THE AUSTRALIAN CONSUMER LAW TO, AT ITS OPTION, THE REPAIR OR REPLACEMENT OF THE PRODUCTS, THE SUPPLY OF EQUIVALENT PRODUCTS, OR THE PAYMENT OF THE COST OF SUCH REPAIR OR REPLACEMENT OR THE ACQUISITION OF EQUIVALENT PRODUCTS.

THE WARRANTY SET OUT IN THIS DOCUMENT IS GIVEN BY CATERPILLAR INC. OR ANY OF ITS SUBSIDIARIES, 100 N. E. ADAMS ST, PEORIA, IL USA 61629, TELEPHONE 1 309 675 1000. THE USER IS RESPONSIBLE FOR ALL COSTS ASSOCIATED WITH MAKING A CLAIM UNDER THE WARRANTY SET OUT IN THIS DOCUMENT, EXCEPT AS EXPRESSLY STATED OTHERWISE IN THIS DOCUMENT, AND THE USER IS REFERRED TO THE BALANCE OF THE DOCUMENT TERMS CONCERNING CLAIM PROCEDURES, CATERPILLAR RESPONSIBILITIES AND USER RESPONSIBILITIES.

TO THE EXTENT PERMISSIBLE BY LAW, THE TERMS SET OUT IN THE REMAINDER OF THIS WARRANTY DOCUMENT (INCLUDING SECTION B) CONTINUE TO APPLY TO PRODUCTS TO WHICH THIS SECTION C APPLIES.

©2018 Caterpillar All Rights Reserved.

CAT, CATERPILLAR, their respective logos, "Caterpillar Yellow" the "Power Edge" trade dress as well as corporate and product identity used herein, are trademarks of Caterpillar and may not be used without permission.

CARTER POWER SYSTEMS

Section Four DRAWINGS

Layout Assembly Drawings

Electrical Interconnect Control Terminals

Schedule of Wiring Runs

Remote Annunciator Wiring Diagrams

Recommended Cable for Remote Annunciator

This page intentionally left blank

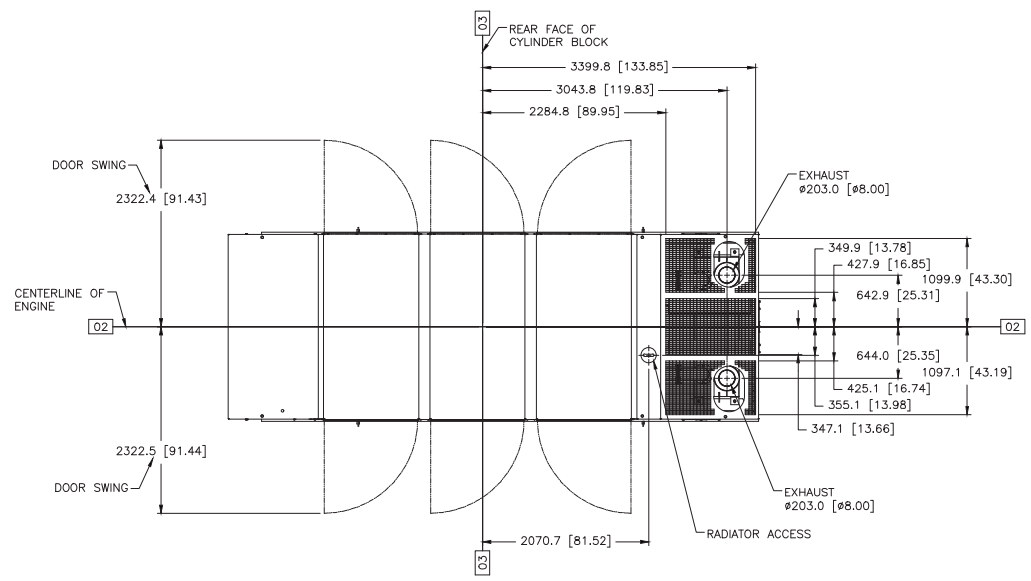

TOP VIEW

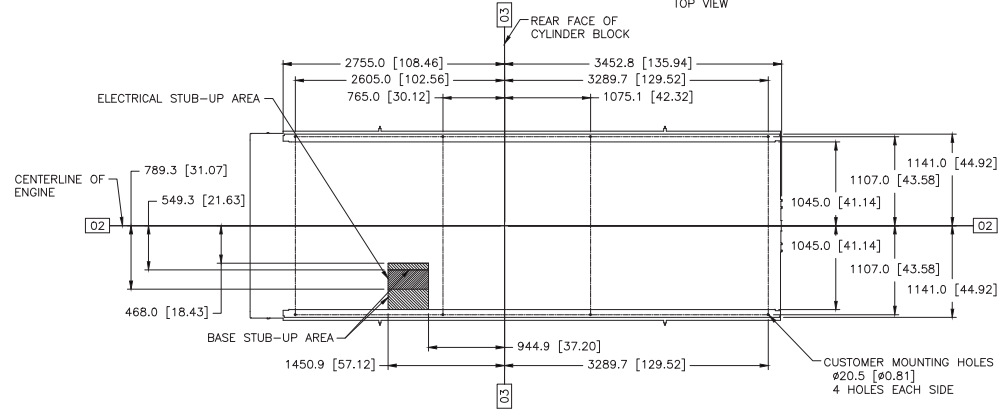

FOOTPRINT

LF-5711 WITH LF-5684 SHOWN

DATE	
BY	
CHKD	
APP'D	
REV	
1	ISSUE
2	REVISED
3	REVISED
4	REVISED
5	REVISED
6	REVISED
7	REVISED
8	REVISED
9	REVISED
10	REVISED
11	REVISED
12	REVISED
13	REVISED
14	REVISED
15	REVISED
16	REVISED
17	REVISED
18	REVISED
19	REVISED
20	REVISED
21	REVISED
22	REVISED
23	REVISED
24	REVISED
25	REVISED
26	REVISED
27	REVISED
28	REVISED
29	REVISED
30	REVISED
31	REVISED
32	REVISED
33	REVISED
34	REVISED
35	REVISED
36	REVISED
37	REVISED
38	REVISED
39	REVISED
40	REVISED
41	REVISED
42	REVISED
43	REVISED
44	REVISED
45	REVISED
46	REVISED
47	REVISED
48	REVISED
49	REVISED
50	REVISED
51	REVISED
52	REVISED
53	REVISED
54	REVISED
55	REVISED
56	REVISED
57	REVISED
58	REVISED
59	REVISED
60	REVISED
61	REVISED
62	REVISED
63	REVISED
64	REVISED
65	REVISED
66	REVISED
67	REVISED
68	REVISED
69	REVISED
70	REVISED
71	REVISED
72	REVISED
73	REVISED
74	REVISED
75	REVISED
76	REVISED
77	REVISED
78	REVISED
79	REVISED
80	REVISED
81	REVISED
82	REVISED
83	REVISED
84	REVISED
85	REVISED
86	REVISED
87	REVISED
88	REVISED
89	REVISED
90	REVISED
91	REVISED
92	REVISED
93	REVISED
94	REVISED
95	REVISED
96	REVISED
97	REVISED
98	REVISED
99	REVISED
100	REVISED

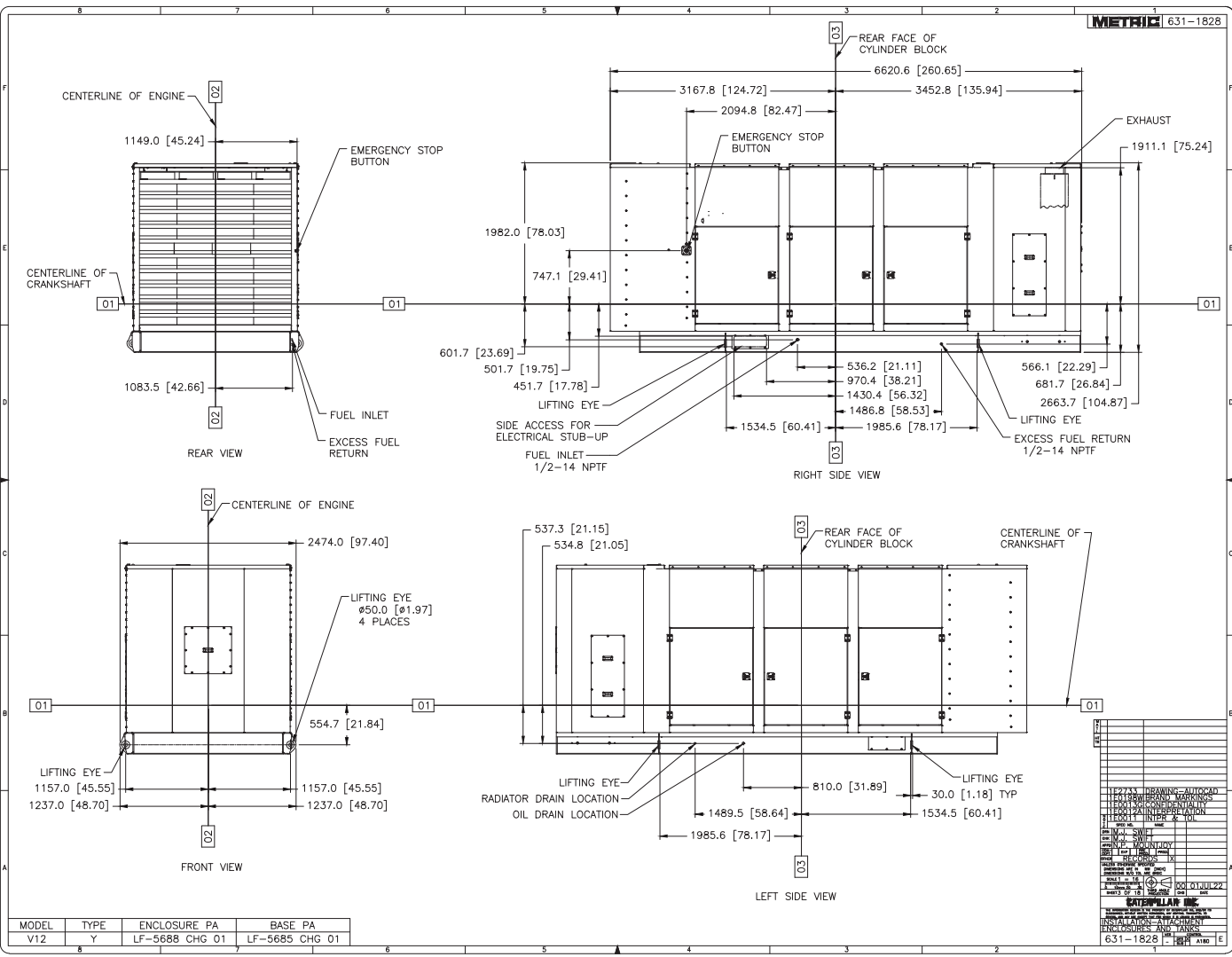

MODEL	TYPE	ENCLOSURE PA	BASE PA
V12	Y	LF-5688 CHG 01	LF-5685 CHG 01

DATE	
BY	
CHKD	
APP'D	
REV	
1	ISSUE
2	
3	
4	
5	
6	
7	
8	
9	
10	
11	
12	
13	
14	
15	
16	
17	
18	
19	
20	
21	
22	
23	
24	
25	
26	
27	
28	
29	
30	
31	
32	
33	
34	
35	
36	
37	
38	
39	
40	
41	
42	
43	
44	
45	
46	
47	
48	
49	
50	
51	
52	
53	
54	
55	
56	
57	
58	
59	
60	
61	
62	
63	
64	
65	
66	
67	
68	
69	
70	
71	
72	
73	
74	
75	
76	
77	
78	
79	
80	
81	
82	
83	
84	
85	
86	
87	
88	
89	
90	
91	
92	
93	
94	
95	
96	
97	
98	
99	
100	

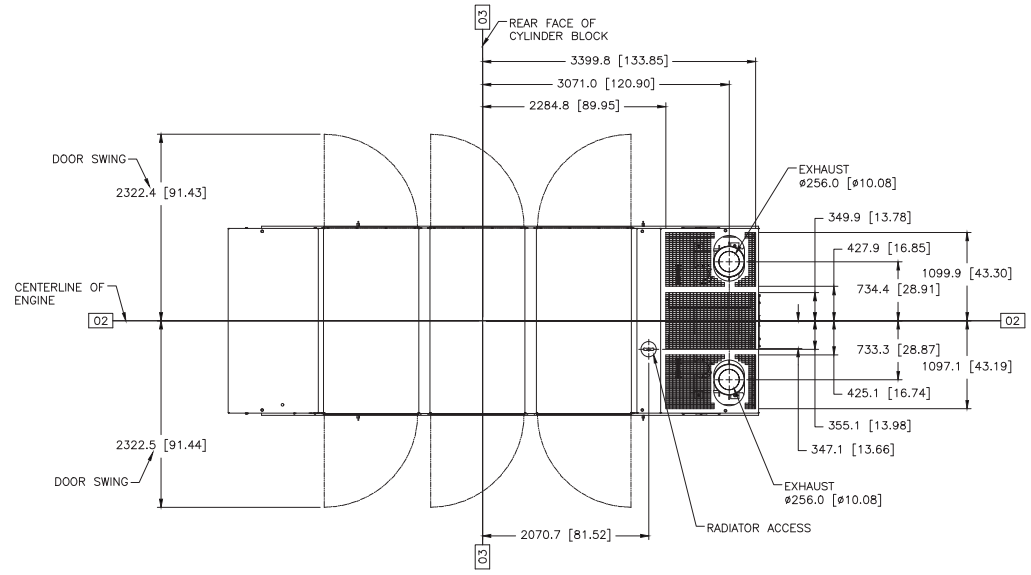

TOP VIEW

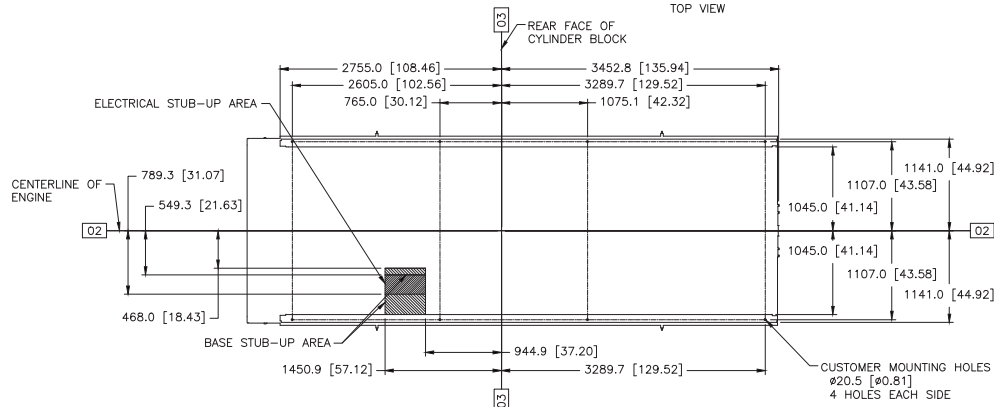

FOOTPRINT

DATE	
BY	
CHKD	
APP'D	
REV	
1	01JUL22
1E2711 DRAWING-AUTOCAD 1E0180 MERRIN, MARRONS 1E0030 PRODUCTION 1E0029 INTERPRETATION 1E0011 INSP & TOL 1E0001 DES 1E0000 MFG	
METRIC 631-1828	

LF-5688 WITH LF-5685 SHOWN

MAIN WIRING HARNESS

GP-58-8045
GP-58-8045
GP-58-8045

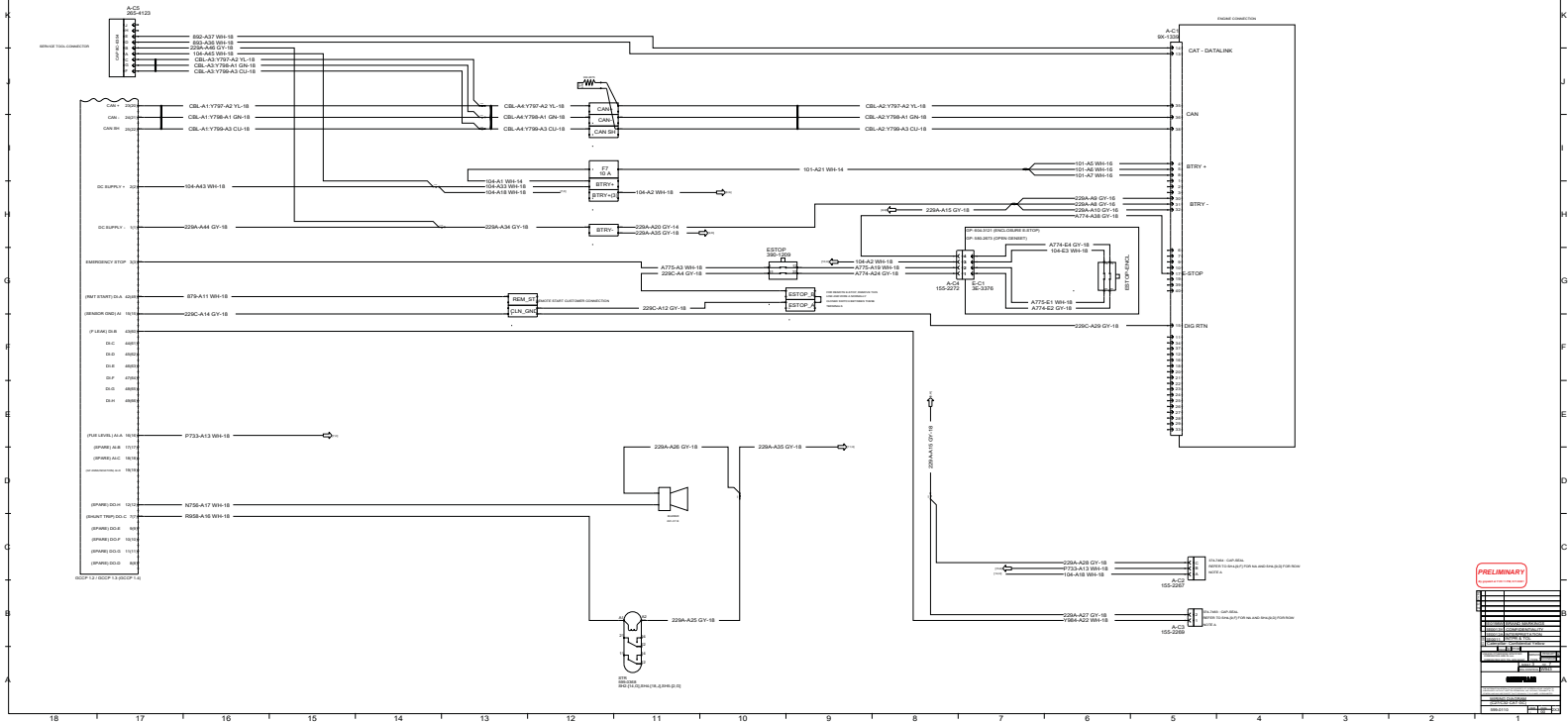

1	2	3	4	5	6	7	8	9	10	11	12	13	14	15	16	17	18	
A	B	C	D	E	F	G	H	I	J	K	L	M	N	O	P	Q	R	S

PRELIMINARY
 This drawing is preliminary and is subject to change without notice.
 All dimensions are in millimeters unless otherwise specified.
 All components are to be installed in accordance with the manufacturer's instructions.
 All wiring is to be done in accordance with the applicable wiring diagrams and standards.
 All components are to be installed in a clean, dry, and well-ventilated area.
 All components are to be installed in a secure and accessible location.
 All components are to be installed in a location that is protected from moisture and corrosion.
 All components are to be installed in a location that is protected from vibration and shock.
 All components are to be installed in a location that is protected from electromagnetic interference (EMI).
 All components are to be installed in a location that is protected from radio frequency interference (RFI).
 All components are to be installed in a location that is protected from static electricity (ESD).
 All components are to be installed in a location that is protected from dust and debris.
 All components are to be installed in a location that is protected from heat and cold.
 All components are to be installed in a location that is protected from sunlight and UV radiation.
 All components are to be installed in a location that is protected from fire and smoke.
 All components are to be installed in a location that is protected from theft and vandalism.
 All components are to be installed in a location that is protected from unauthorized access.
 All components are to be installed in a location that is protected from tampering and sabotage.
 All components are to be installed in a location that is protected from espionage and intelligence gathering.
 All components are to be installed in a location that is protected from cyber attacks and data breaches.
 All components are to be installed in a location that is protected from physical attacks and sabotage.
 All components are to be installed in a location that is protected from natural disasters and environmental hazards.
 All components are to be installed in a location that is protected from human error and misuse.
 All components are to be installed in a location that is protected from malicious intent and terrorism.
 All components are to be installed in a location that is protected from all threats and risks to the system.

ADDITIONAL OPTIONS

ENCLOSURE LIGHTS

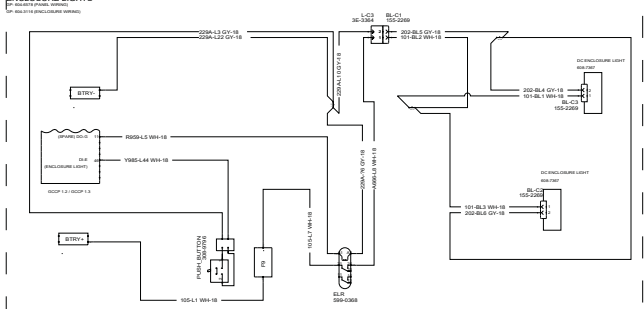

GENERAL FAULTY RELAY/GENSET RUNNING RELAY

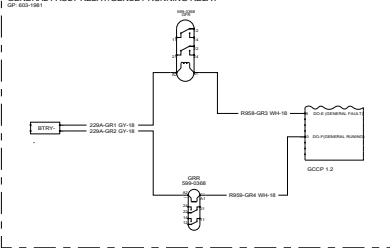

LOAD CENTER

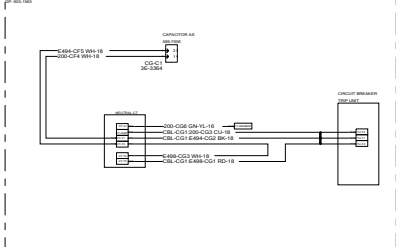

BATTERY CHARGER OPTION (110-150V POWER SUPPLY)

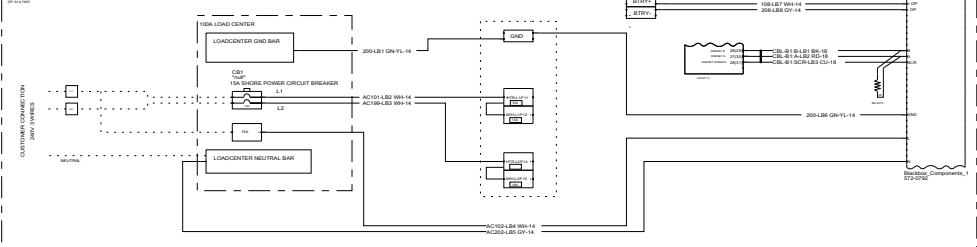

REVISION	DATE	BY	CHKD
1			
2			
3			
4			
5			
6			
7			
8			
9			
10			
11			
12			
13			
14			
15			
16			
17			
18			

PRELIMINARY

This page intentionally left blank

CARTER POWER SYSTEMS

Section Five

ADDITIONAL POWER SYSTEMS ACCESSORIES

**Custom UL2085 Sub-base tank
Triple Breaker Docking Station
Custom Access Stair and Platform**

This page intentionally left blank

JOB #	TANK CAPACITY ACTUAL	TANK CAPACITY USEABLE	TANK WEIGHT	GENSET MODEL	GENSET FOOTPRINT
37060	2195 GAL	2100 GAL	15,500 LBS	D1250 GC SAE	97.4" X 243.9"

THE INFORMATION CONTAINED IN THIS DRAWING IS THE SOLE PROPERTY OF GLOBAL POWER COMPONENTS. ANY REPRODUCTION IN PART OR WHOLE WITHOUT THE WRITTEN PERMISSION OF GLOBAL POWER COMPONENTS IS PROHIBITED.

APPROVED BY: _____ **DATE:** _____

*** = 2" PIPE TO TANK TOP UNLESS OTHERWISE NOTED**

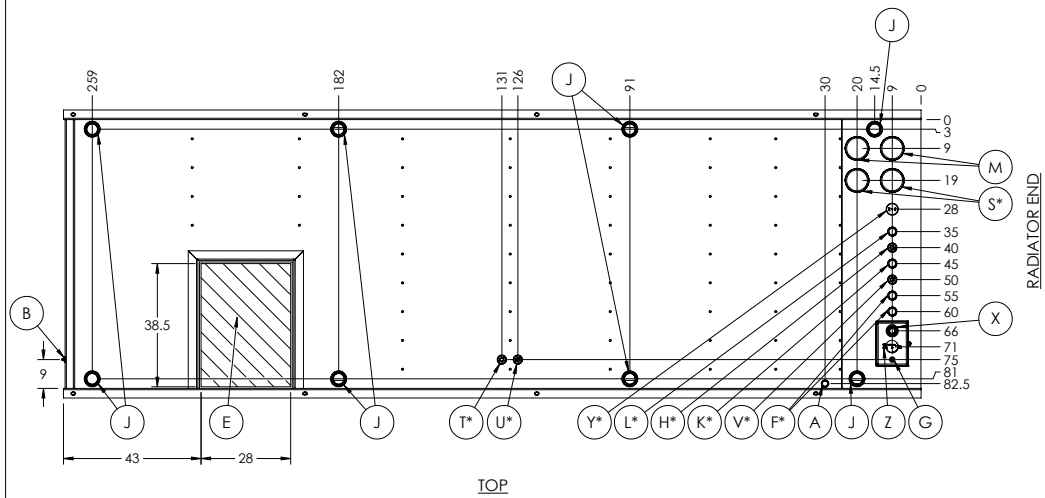

BILL OF MATERIALS			
ITEM NO.	PART NUMBER	DESCRIPTION	QTY.
S	3166	F. COUPLING, 6", EMERGENCY VENT (6" PIPE)	2
T	3660R	F. COUPLING, 2", FUEL RETURN W/ 1" DIP TUBE	1
U	3660S	F. COUPLING, 2", FUEL SUPPLY W/ 1" DIP TUBE	1
V	1000	F. COUPLING, 2", LOW LEVEL ALARM (SET AT 13")	1
X	1002	FLANGE, 2", 2' X 1-1/2" REDUCING BUSHING SPIRAL FUEL LEVEL GAUGE (SET AT 27-1/2")	1
Y	3152	F. COUPLING, 2", STANDARD VENT CAP	1
Z	3005	FLANGE, 2", LOCKING FILL PORT	1
A	4300	F. COUPLING, 1-1/2", FUEL IN BASIN ALARM	1
A	4301	PIPE, 1-1/2" INTERSTITIAL MONITORING TUBE, 30-1/2'L	1
B	3502	FLANGE, 1/2", BASIN DRAIN	1
C	8410	1/2" FLUSH MOUNT LIFTING PLATE	8
D	8002	REMOVABLE STUB UP ACCESS PANEL	1
E	4001	NOTCHED ELECTRICAL STUB UP AREA	1
F	3195	F. COUPLING, 2", EXTRA FITTING W/ PLUG	2
G	3190	FLANGE, 3/8", EXTRA FITTING W/ PLUG	1
H	1010	F. COUPLING, 2", HIGH LEVEL ALARM (SET AT 7-1/2")	1
J	3196	FLANGE, 3", EXTRA FITTING W/ PLUG	8
K	1020	F. COUPLING, 2", CRITICAL HIGH LEVEL ALARM (SET AT 6")	1
L	1005	F. COUPLING, 2", CRITICAL LOW LEVEL ALARM (SET AT 25-1/4")	1
M	3166	F. COUPLING, 6", EMERGENCY VENT (BASIN)	2
	8220	7 GALLON SPILL CONTAINMENT	1
	3520	RAIN RUNOFF@ OPTION	1
	NFPA	LABEL - NFPA DIESEL	1
UL-2085		2 HOUR FIRE RATED DOUBLE WALL TANK	
PAINT COLOR		GLOSS BLACK (9638)	

- NOTES:
1. APPLY NFPA LABEL
 2. USE ALL 8 LIFT EYES
 3. WELD COUPLINGS LEVEL
 4. WEIGHT W/O CONCRETE: 7,700 LBS

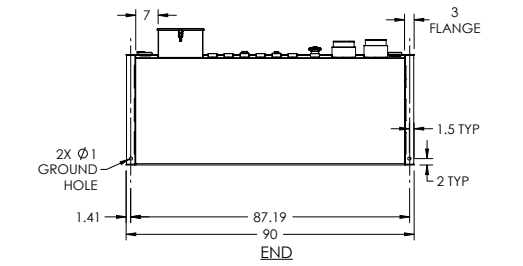
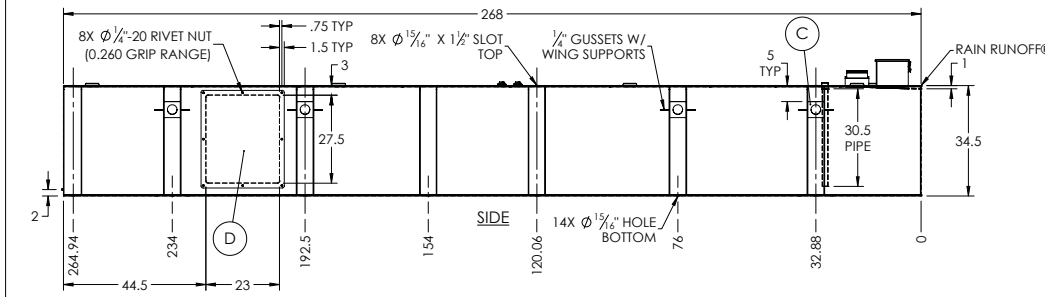

REVISIONS			
REV.	DESCRIPTION	DATE	BY

GLOBAL POWER COMPONENTS™

200 S. State
MILWAUKEE, WI 53215
PH 414.475.3000 FAX 414.475.3015
www.globalpowercomponents.com

Underwriters Laboratories Inc.
Listed
MH118481
FILE NO. MH44243
MH25279

THIRD ANGLE PROJECTION

CUSTOMER NAME: CARTER CAT	DATE: 7/22/2022
JOB REFERENCE: SENECA	DESCRIPTION: SUBBASE TANK WITH RUPTURE BASIN NOTCHED STUB UP
DRAWING REFERENCE: X	DRAWN BY: RDG
	SHEET B
	DWG. NO. 15-37060
	SCALE: 1:30

JOB #
37060



THE INFORMATION CONTAINED IN THIS DRAWING IS THE SOLE PROPERTY OF GLOBAL POWER COMPONENTS. ANY REPRODUCTION IN PART OR WHOLE WITHOUT THE WRITTEN PERMISSION OF GLOBAL POWER COMPONENTS IS PROHIBITED.

APPROVED BY:

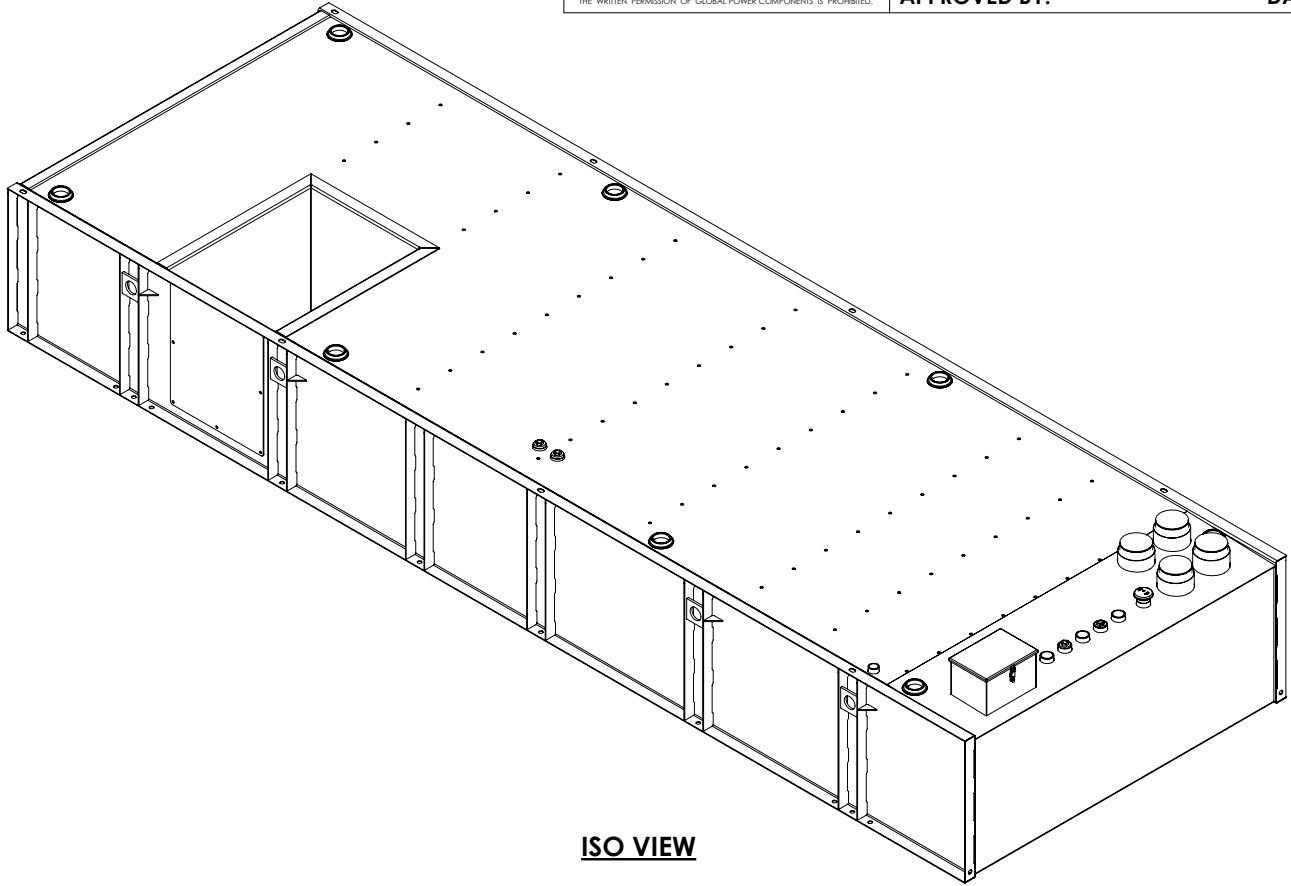
DATE:



ISO VIEW

 200 S. 51st ST MILWAUKEE, WI 53219 PH 414.475.3000 FAX 414.475.2411 www.globalpowercomponents.com	 Underwriters Laboratories® Inc. Listed MH18481 FILE NO. MH44243 MH25279 NFC COMPONENTS INC. SHEET 3 OF 8	 THIRD ANGLE PROJECTION	CUSTOMER NAME: CARTER CAT	DATE: 7/22/2022	DESCRIPTION: ISO VIEW	
			JOB REFERENCE: SENECA	DRAWN BY: RDG	SIZE: B	DWG. NO. 15-37060
			DRAWING REFERENCE: X	SCALE: 1:1	REV.:	

2000A DUAL PURPOSE PAD MOUNT QUICK CONNECT PANEL

QCPM20H2MFHW20G30TIS020IS020LDB20

480/277V 3 PHASE

2000A DUAL PURPOSE PAD MOUNT QUICK CONNECT
PANEL WITH TWO ISOLATION BREAKERS AND A LOAD
DUMP BREAKER

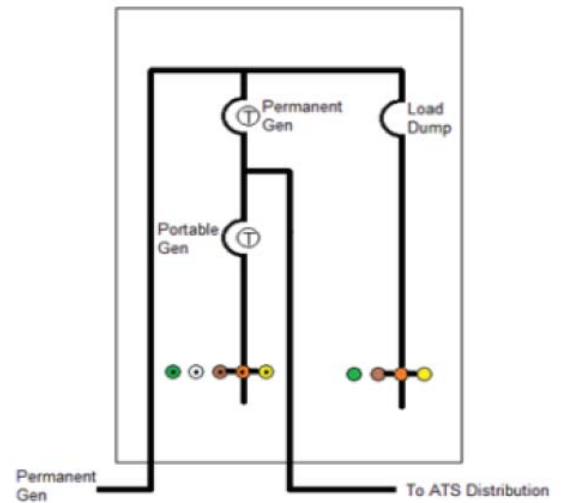

Material: Nema 3RX Powder Coated Aluminum ANSI Gray

Description: 2000A 480/277V Dual Purpose Pad Mount Quick Connect Panel
 (2) 2000A 3 Pole Isolation Breakers with with Trapped Key Interlock
 (1) 2000A 3 Pole Load Dump Breaker with 24VDC Shunt Trip
 Angled Male Cam-Loks with Smart Lugs and Pad Lockable Cover Door
 45° Angled Female Load Bank Cam-Loks with Flip Covers and Pad Lockable Cover Door
 Tamper Resistant While In Use
 100 kA Rated Plated Copper T-Slot Buss with Mechanical Lugs
 Phase Rotation Monitor
 2 Wire Auto-Start Terminals with Signal Destination Switch
 Feed Through Lugs
 20A GFCI Duplex Receptacle With Breaker (External 120V Power Required)
 30A L5-30 Twist Lock Receptacle with Breaker (External 120V Power Required)
 (2) Trapped Key Interlock FS/Q Lock for Isolation Breakers
 (2) Trapped Key Breaker Adaptation and Pad Lock Kits
 Bottom, Back and Side Conduit Access
 Side and Back Access Plates
 cETLus Listed, Conforms to UL STD 1008, Certified to CAN/CSA STD C22.2 NO. 178

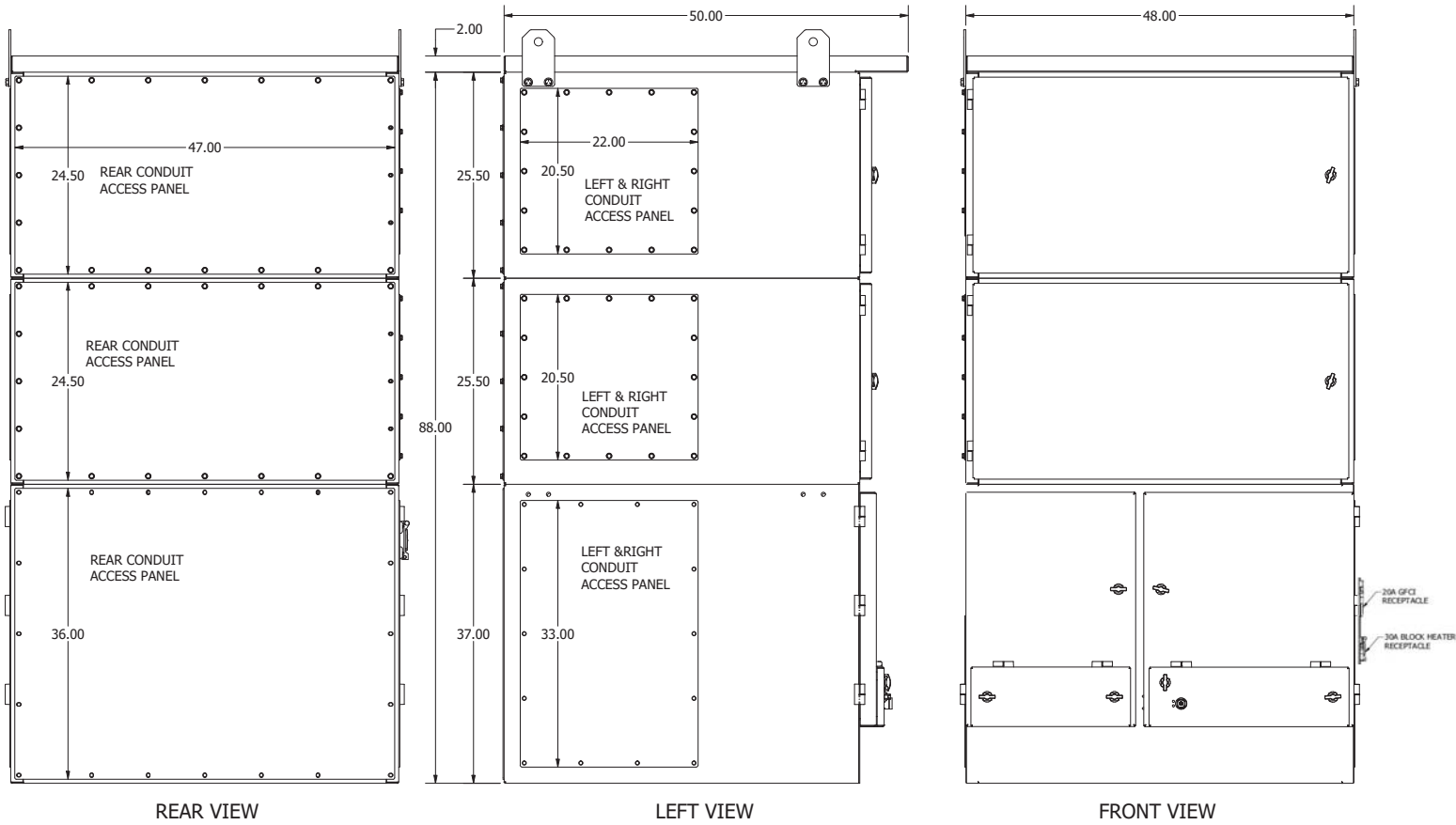

CABLING NOTES

AMPS	QUANTITY OF CAM-LOKS / LUGS			SIZE
	PHASE	NEUTRAL	GROUND	
2000A 5 WIRE	5/7	5/7	2/2	#2 - 600 kcmil
2000A 4 WIRE	5/7	-/-	2/2	#2 - 600 kcmil

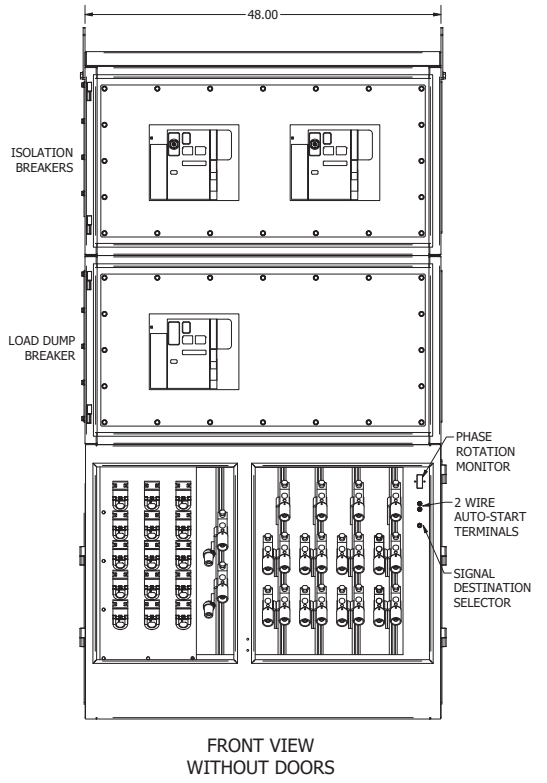
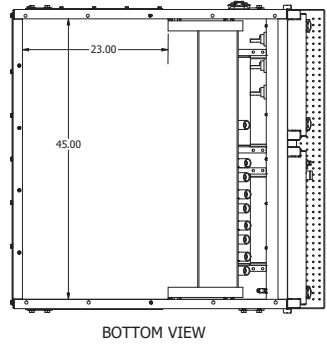

GENERAL NOTES

1. TYPE 3RX ENCLOSURE. 1/8" ALUMINUM OR OPTIONAL 14 GA. 304SS OR 316SS.
2. INLET PANEL IS FOR USE ONLY FOR CONNECTION OF A GENERATOR TO THE SOURCE TERMINALS OF A TRANSFER SWITCH SUCH THAT THE INLETS ARE ENERGIZED FROM THE GENERATOR.
3. cETLus LISTED, CONFORMS TO UL STD 1008, CERTIFIED TO CAN/CSA STD C22.2 NO. 178
4. SHORT CIRCUIT CURRENT RATINGS AS SPECIFIED IN PURCHASE DOCUMENTS.
5. REMOVABLE 11 GAUGE ALUMINUM OR OPTIONAL 316SS HINGE DOOR WITH PADLOCK PROVISIONS.
6. FINISH: ANSI 61 GRAY POWDER COAT.
7. REMOVABLE GASKETED SIDE ACCESS PANELS ARE ADDITIONAL CONDUIT ENTRY AREAS.
8. RECOMMENDED CLEARANCES: FRONT 24 TO 30 INCHES
9. REMOVABLE GROUNDING STRAP(S) ARE INCLUDED CONNECTING THE GREEN CAMLOCKS TO THE ENCLOSURE.
10. NO NEUTRAL TO GROUND BONDING PROVISIONS INCLUDED.
11. CAMLOCK CONNECTORS ARE SERIES 16 COMPATIBLE. 400A RATED.
12. INSTALLATION: SURFACE TO WHICH THE PANEL IS TO BE INSTALLED AND THE INSTALLATION METHOD / HARDWARE MUST BE CAPABLE OF SUPPORTING THE WEIGHT OF THE PANEL AS WELL AS THE WEIGHT OF THE TEMPORARY CABLES TO BE ATTACHED TO IT. THE INSTALLATION IS TO BE DONE BY QUALIFIED PERSONNEL IN ACCORDANCE WITH LOCAL AND NATIONAL CODES AND GOOD ENGINEERING PRACTICES. THE PANEL MUST BE LEVEL AND PLUMB TO ALLOW FOR PROPER DRAINAGE / WATER RUNOFF.

**CL 16 Series Bus Bar Mount Inlet (400A / 600V) Male Offset -
Black (A)**
Part # CL40MR-OFFSET-A



product specifications for:

CLS 45 Degree Panel Mounts

Item #: CLS45FRB-BB2

Description

CAM CLS 45 Two hole bus bar 5/16"-18 thread Female Panel Mount

Electrical Specifications

Max. Amperage: 400A

Max. Voltage: 600V AC/DC

Material Specifications

Housing Material: Santoprene TPV

Contact Material: One piece solid Brass

Temperature Rating: -40°C to 105°C

Mechanical Specification

Gender: Female

Connection Type: Two hole 5/16"-18 thread bus bar
(Torque to 100 in.-lbs., do not over tighten)

Mounting: Brass eyelet for #10-32 through bolt
(Bolts Not Provided)

Example: CLS45FRB-BB2 + **A** = CLS45FRB-BB2-A

A **B** **C** **D** **E** **F** **G** **H**



Standards and Certifications

UL Listed: File E111198

Environmental Rating: Type 3R & 4

product specifications for:

Cam Protective Covers

Item #: 203445

Description

45 Degree Panel Mount - cover adapter bracket

Material Specifications

Bracket Material: Stainless Steel

Mounting Screws: Stainless Steel

Mechanical Specification

Fits all Marinc Power Products 45 Degree Panel Mounts (Male and Female)

- CLS45MRSB and CLS45FRSB
- CLS45MRB and CLS45FRB
- CLS45MR2SB and CLS45FR2SB
- CLS45MRB-BB and CLS45FRB-BB
- CLS45MRB-BB2 and CLS45FRB-BB2

Fits all Marinc Power Products CL40WTC covers:

- CL40WTC-L-125: Surface Mount Cover
- CL40WTC-S-062: Through Mount (.370" to .400" panel thickness)
- CL40WTC-L-187: Through Mount (.070" to .090" panel thickness)

Qty: 2 #10-32 Phillips drive screws included to mount bracket to CL40WTC cover

Screws not included to mount bracket to panel mount (#10-32 recommended)

Standards and Certifications

Environmental Rating: Type 1R with CL40WTC cover

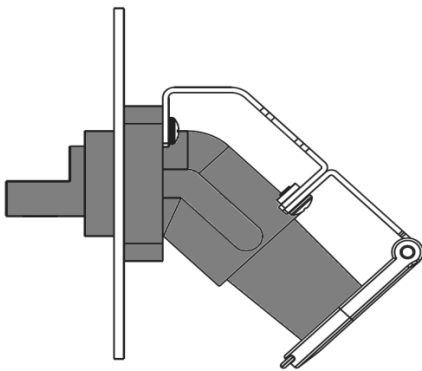

CL40WTC-L-125

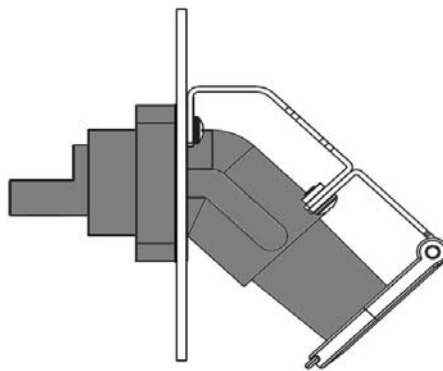

CL40WTC-L-187

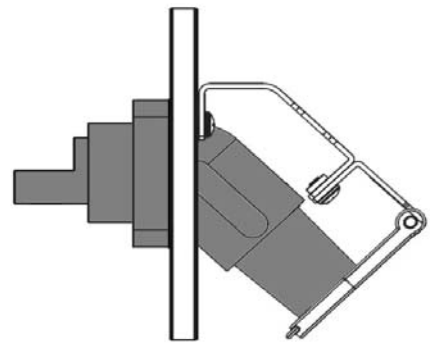

CL40WTC-S-062

toll free 800.307.6702 | marincopowerproducts.com

©2015 Marinc Power Products. All rights reserved.

MARINCO
power products

Smart Buss System 1600 - 8000A

- . Heat Dissipation Jumpers
- . T-Slot Adjustable Plated Copper Main Buss
- . 100 kAIC Rated
- . UL and ETL Tested and Certified
- . 30,000V Rated

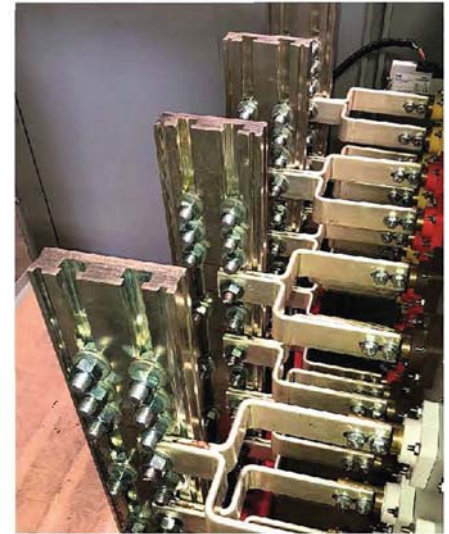
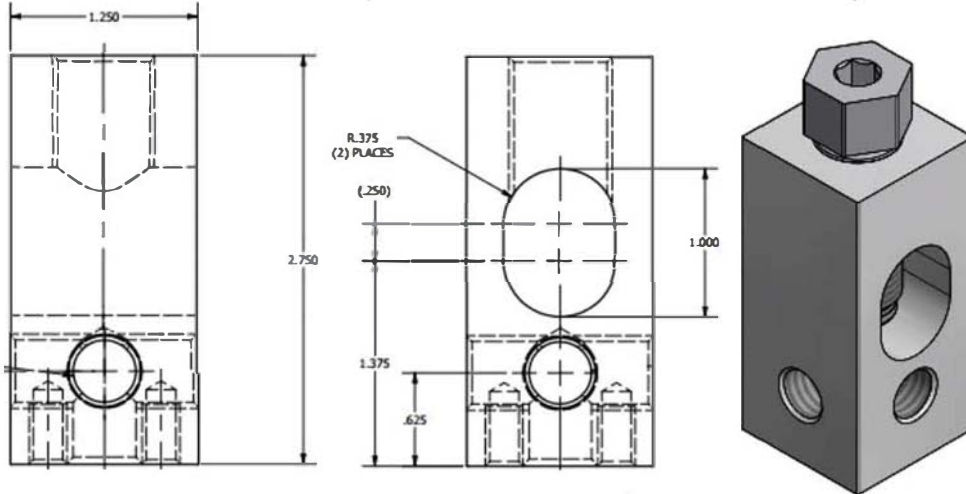
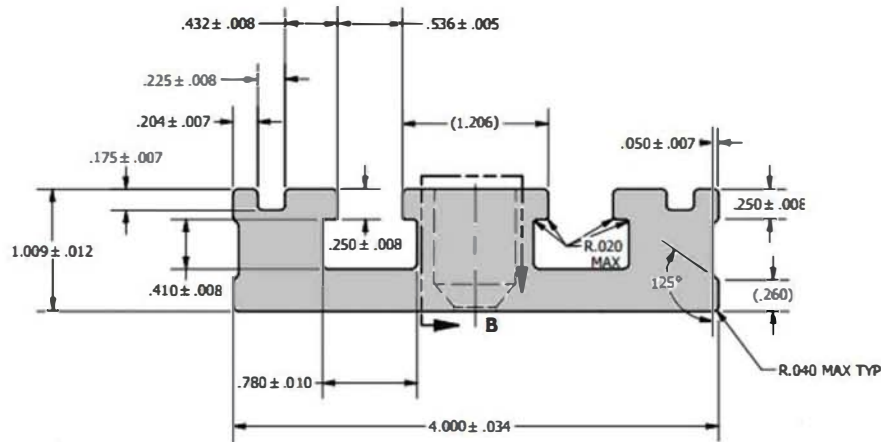
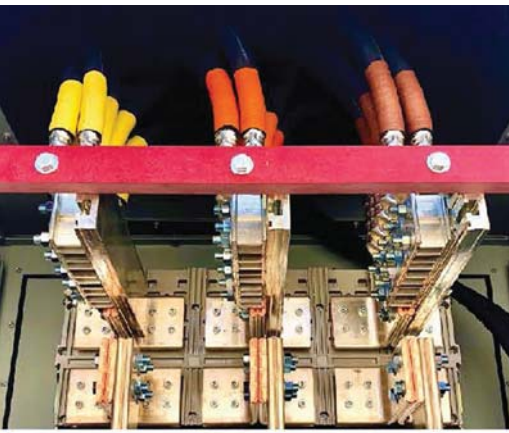

Smart Buss with Cam-Loks and Smart Lugs

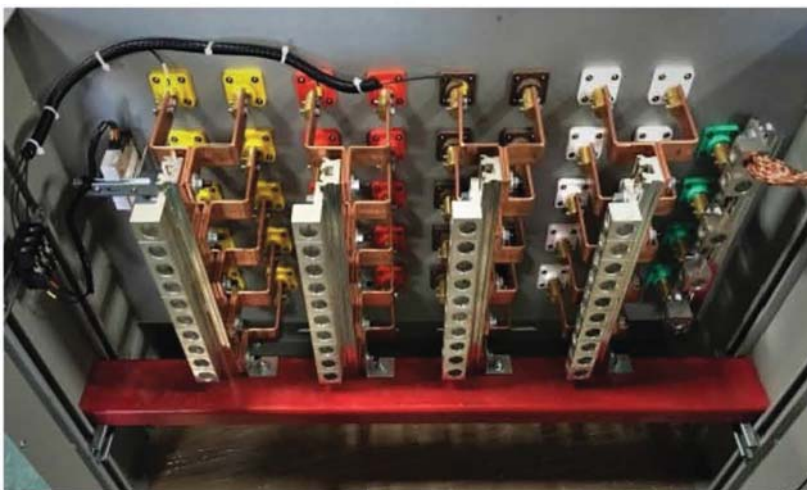

Product data sheet

Characteristics



RM17TG00

phase control relay RM17-T range 183..528 V AC

Main

Range of product	Zelio Control
Product or component type	Modular measurement and control relays
Relay type	Control relay
Product specific application	For 3-phase supply
Relay name	RM17TG
Relay monitored parameters	Phase sequence Phase failure detection
Time delay	Without
Switching capacity in VA	1250 VA
Measurement range	208...480 V voltage AC

Complementary

Maximum switching voltage	250 V AC 250 V DC
Minimum switching current	10 mA 5 V DC
Supply voltage limits	183...528 V AC
Control circuit voltage limits	- 12 % + 10 % Un
Power consumption in VA	0...22 VA 400 V AC 50 Hz
Voltage detection threshold	< 100 V AC
Control circuit frequency	50...60 Hz +/- 10 %
Output contacts	1 C/O
Nominal output current	5 A
Measurement voltage limits	183...528 V AC
Delay at power up	650 ms
Voltage range	183...528 V
Response time	<= 130 ms in the event of a fault)
Marking	CE
Overvoltage category	III IEC 60664-1
Insulation resistance	> 500 MOhm 500 V DC IEC 60255-5 > 500 MOhm 500 V DC IEC 60664-1
[Ui] rated insulation voltage	400 V IEC 60664-1
Supply frequency	50/60 Hz +/- 10 %
Operating position	Any position without
Connections - terminals	Screw terminals, 1 x 0.5...1 x 4 mm ² AWG 20...AWG 11) solid without cable end Screw terminals, 2 x 0.5...2 x 2.5 mm ² AWG 20...AWG 14) solid without cable end Screw terminals, 1 x 0.2...1 x 2.5 mm ² AWG 24...AWG 12) flexible with cable end Screw terminals, 2 x 0.2...2 x 1.5 mm ² AWG 24...AWG 16) flexible with cable end
Tightening torque	5.31...8.85 lbf.in (0.6...1 N.m) IEC 60947-1
Housing material	Self-extinguishing plastic
Local signalling	Relay ON LED yellow)
Mounting support	35 mm symmetrical DIN rail EN/IEC 60715
Electrical durability	100000 cycles
Mechanical durability	30000000 cycles
Operating rate	<= 360 operations/hour full load

Binding Post - Insulated Standard

SPECIFICATIONS

Stud: Brass per QQ-B-626D

Finish: Silver

Insulating Material: Nylon 6/6 per
ASTM D4066

Hardware: Nickel plated nut (unassembled)

Body Thread Stripping Torque:
6.0 lb. in. (7.0 kg cm)

Panel Thickness: Up to .281 (7.15)

RATINGS

Current: 15 amps

Contact Resistance: 0.010 ohms maximum

Breakdown Voltage: 5700 Vrms minimum

Stud-to-Panel: 3.3 pF nominal



SILVER PLATING	
111-0103-001	Black

For Standard Banana Plug: .175 (4.44) Dia.

FEATURES:

- Turret terminal
- Captive thumb nut
- Insulated body is flatted to prevent turning
- Nylon UL approved for self-extinguishing

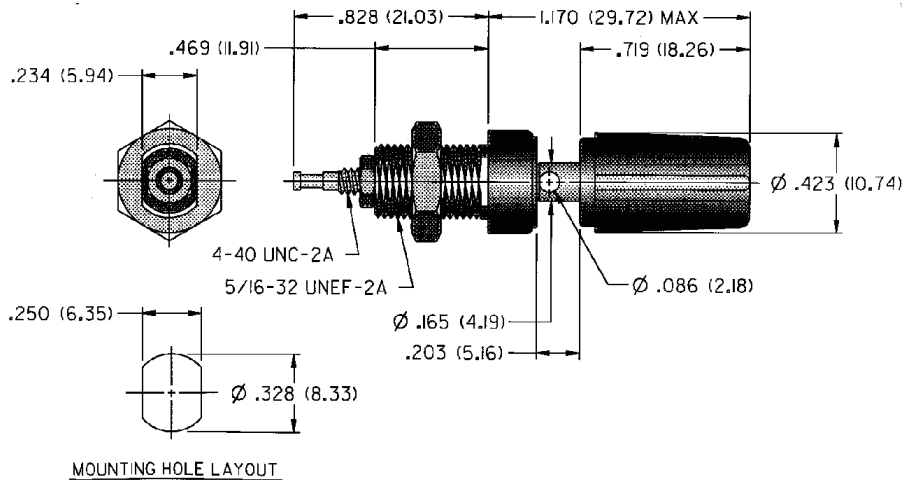

Toggle Switch

2 Position, Rounded, Maintained, 6 Terminals, DPDT, 6A

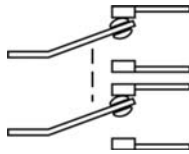

DPDT Wiring Diagram

Switch Type	Manual
Actuator Style	Toggle
Toggle Style	Rounded
Illumination	Not Illuminated
Number of Positions	2
Number of Circuits Controlled	2
Switch Starting Position	2 Off (Normally Open) or 2 On (Normally Closed)
Switch Action	Stays Switched (Maintained)
Number of Terminals	6
Industry Designation	DPDT
Position Designation	On-On
Switching Current @ Voltage	6 A @ 125 V AC/28 V DC
Maximum Voltage	28V DC 250V AC
Mounting Location	Panel
For Panel Cutout Diameter	1/2"
For Maximum Panel Thickness	0.13"
Toggle	
Depth	0.56"
Diameter	0.24"
Mounting Thread	
Size	15/32"-32
Type	UNS
Mounting Hardware Included	Yes
Wire Connection Type	Quick-Disconnect Terminals, Screw Terminals
Specifications Met	UL Recognized, CSA Certified
RoHS	RoHS 3 (2015/863/EU) Compliant
REACH	REACH (EC 1907/2006) (06/25/2020, 209 SVHC) Compliant
DFARS	Specialty Metals COTS-Exempt
Country of Origin	United States



UPC Code : 078477809471

Country Of Origin : Please Contact Customer Service.



2610

30 Amp, 125 Volt, NEMA L5-30R, 2P, 3W, Flush Mtg Locking Receptacle, Industrial Grade, Grounding, V-0-MAX - BLACK

Leviton's Industrial Grade Locking Devices are built to provide unparalleled quality and superior performance in the most severe industrial settings. Leviton combines the best materials available with superior production standards to produce a broad selection of Locking Devices of unmatched flexibility and dependability.

- Ideal for generators and camper trailers

Technical Information

AC Horsepower Ratings

At Rated Voltage : 2 HP

Electrical Specifications

Amperage : 30 A

Current Limiting : Full Rated Current

Dielectric Voltage : Withstands 2000V per UL498

Grounding : Grounding

Pole : 2

Temperature Rise : Max 30C after 250 cycles OL at 200 percent rated current

Voltage : 125 VAC

Wire : 3

Environmental Specifications

Environment : Corrosive

Flammability : Rated V-0 per UL 94

Operating Temperature : -40°C to 60°C

Material Specifications

Base Material : Valox

Body Material : Nylon

Color : Black

Cover Material : Valox 357

Face Material : Ultramid

Ground Contacts : Brass

Grounding Screw : Chromated Brass

Line Contacts : Brass

Strap Material : Nickel-Plated Brass

Terminal Clamps : Nickel-Plated Brass

Terminal Screws : Chromated Brass

Mechanical Specifications

Cord Range : 0.595 to 1.150

Product ID : Ratings and NEMA I.D. permanently marked on device

Terminal Accom. : 14-8 AWG

Terminal ID : Marked on Device

Termination : Back & Side

Product Features

Base Material : Valox

Brand : V-0-Max

Color : Black

Device Type : Locking Receptacle

Face Material : Ultramid

NEMA : L5-30R

Warranty : Lifetime Limited

Standards and Certifications

ANSI : C-73

CSA : C22.2 No. 42

NEMA : WD-1 & WD-6

NOM : 057

UL : 498

UL Fed Spec : W-C-596

Warranty

Warranty : Lifetime Limited

Wiring Diagram

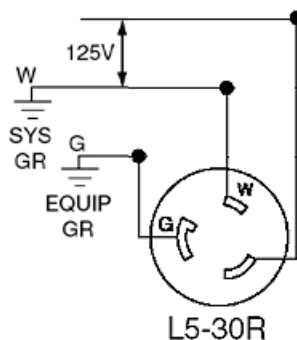

Leviton Manufacturing Co., Inc.

201 North Service Road, Melville, NY 11747

Telephone: +1-800-323-8920 · FAX: +1-800-832-9538 · Tech Line (8:30AM-7:30PM E.S.T. Monday-Friday):
+1-800-824-3005

Leviton Manufacturing of Canada, Ltd.

165 Hymus Boulevard, Pointe Claire, Quebec H9R 1E9 · Telephone: +1-800-469-7890 ·

FAX: +1-800-824-3005 · www.leviton.com/canada

Leviton S. de R.L. de C.V.

Lago Tana 43, Mexico DF, Mexico CP 11290 · Tel.: (+52)55-5082-1040 · FAX: (+52)5386-
1797 · www.leviton.com.mx

Visit our Website at: www.leviton.com

© 2021 Leviton Manufacturing Co., Inc. All Rights Reserved. Subject to change without notice.

Leviton has a global presence.

If you would like to know where your local Leviton office is located please go to:

www.leviton.com/international/contacts/





Color :  Gray

UPC Code : 078477709139

Country Of Origin : China

RoHS Compliant : Yes

NEMA :  5-20R

Available Colors :



Black



Ivory



Light Almond

White

GFWT2-GY

20 Amp, 125 Volt Receptacle/Outlet, 20 Amp Feed-Through, Self-test SmartlockPro Slim Weather & Tamper-Resistant GFCI, Monochromatic, Residential/Commercial applications, back and side wired, wallplate/faceplate sold separately - Gray

Peace of mind, all the time. The SmartlockPro Self-Test GFCI tests itself even if you forget. Designed to meet the latest UL standard for auto-monitoring (self-test) our complete line of self-test GFCIs periodically conduct an automatic internal test to confirm that it can respond to a ground fault. With the slimmest profile on the market, the device allows for fast and easy installation, while Leviton's patented reset lockout mechanism prevents reset of the GFCI if it is not wired or operating correctly. The SmartlockPro Self-Test GFCI is the smart choice in ground fault circuit interrupter protection.

Technical Information

Product Features

Amperage : 20 A

At Rated Voltage : 1 HP

Brand : SmartlockPro

Color : Gray

Feature : Self-Test

Fed Spec WC-596 : Yes

Grade : Residential/Commercial Specification Grade

Grounding : Green Ground Screw

NEMA : 5-20R

Pole : 2

Standards and Certifications : UL/CSA, NEMA WD6, NEMA WD1

Strap Material : Stainless Steel

Tamper Resistant : Yes

Termination : Back & Side

Trip Level : Class A, 5mA plus or minus 1mA

Type : Weather Resistant

Voltage : 125 VAC

Wallplate : Not Included

Warranty : 2-Year Limited

Wire : 3

AC Horsepower Ratings

At Rated Voltage : 1 HP

Dielectric Voltage : Withstands 1250VAC per UL 943 and CSA-C22.2 No. 144.1-06

Short Circuit Current Rating : 10KA

Temperature Rise : Max 30C after 100 cycles OL at 150 percent rated current

Electrical Specifications

Dielectric Voltage : Withstands 1250VAC per UL 943 and CSA-C22.2 No. 144.1-06

Operating Temperature : -35C to +66C

Short Circuit Current Rating : 10KA

Temperature Rise : Max 30C after 100 cycles OL at 150 percent rated current

Environmental Specifications

Grounding Screw : Stainless Steel

Line Contacts : Brass Triple-Wipe .031 Thick

Notes : Wallplate Sold Separately

Product ID : Ratings are permanently marked on device

Terminal Accom. : 14-10 AWG

Terminal ID : Brass-Hot, Green-Ground, Silver-Neutral

Terminal Screws : Stainless Steel

Yoke : Stainless Steel

Mechanical Specifications

Amperage : 20 A

Body Material : Polycarbonate

Brand : SmartlockPro

Color : Gray

Face Material : Polypropylene

Feature : Self-Test

Fed Spec WC-596 : Yes

Grade : Residential/Commercial Specification Grade

Grounding : Green Ground Screw

NEMA : 5-20R

Notes : Wallplate Sold Separately

Pole : 2

Product ID : Ratings are permanently marked on device

Standards and Certifications : UL/CSA, NEMA WD6, NEMA WD1

Strap Material : Stainless Steel

Tamper Resistant : Yes

Terminal Accom. : 14-10 AWG

Terminal ID : Brass-Hot, Green-Ground, Silver-Neutral

Termination : Back & Side

Trip Level : Class A, 5mA plus or minus 1mA

Type : Weather Resistant

Voltage : 125 VAC

Warranty : 2-Year Limited

Wire : 3

Body Material : Polycarbonate
Clamps : Brass
Face Material : Polypropylene
Grounding Screw : Stainless Steel
Line Contacts : Brass Triple-Wipe .031 Thick
Notes : Wallplate Sold Separately
Operating Temperature : -35C to +66C
Terminal Screws : Stainless Steel
Yoke : Stainless Steel

Standards and Certifications
ANSI : C-73
CSA C22.2 No. 42 : Yes
CSA-C22.2 No. 144.1-06 : File LR-57811
Fed Spec WC-596 : Yes
MIL-SPEC : A-A-55459-SB
NOM : Yes
UL 943 : File E48380
UL498 : Yes

Material Specifications

Body Material : Polycarbonate
Clamps : Brass
Face Material : Polypropylene

Features and Benefits

- Provides continuous ground fault protection – detects and trips on actual ground fault even when self-test is being conducted
- On initial power up, tests the GFCI within 3 seconds
- Auto-monitoring exceeds the UL requirement
- Auto adapts and shifts to more frequent testing if potential problem is detected
- Status Indicator Light provides simple, intuitive feedback on power and protection status as well as indication of line/load reversal
- Patented Lockout Action prevents reset if GFCI is damaged and cannot respond to a ground fault
- Electronics are designed to minimize any false triggers
- Reduced depth makes it easier to install in any electrical box, even shallow ones
- Terminals allow for easy wiring options – back and side wire capable
- External back wire clamps provide visual indication of proper wire seating
- Withstands high torque and resists wire pullout
- Stainless steel strap and screws, cold impact resistant face and buttons
- Trip threshold meets or exceeds UL requirements for tripping time
- Improved immunity to high-frequency noise reduces nuisance tripping
- Advanced electronics design provides superior resistance to electrical surges and over-voltages
- Compatible with all Decora devices and wallplates; available in select Decora colors
- UL Fed Spec WC-596 rated

Patents*

CA2730014	US8587914
MX302458	US8599522
MX308495	US8944859
US7697252	US9053886

*This list is provided for patent marking purposes only. A good faith effort is made to maintain the accuracy and completeness of this list. No legal inference should be drawn from the omission of a patent from this list.

FS/Q Switchgear Interlock

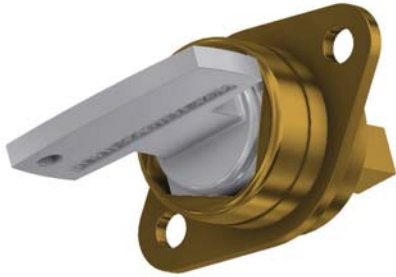

The FS and Q Interlocks are designed for use as a mechanical interlock for electrical switchgear. This is achieved through a mechanical connection to the isolation equipment. The standard unit is fitted with a 9.5mm square x 22mm spigot that can be used to operate an isolator. Inserting and turning the key moves the spigot through a predetermined angular position (45°/65°/90° clock or anti clock wise) moving the isolator to closed. Rotating the key in the opposite direction will open the isolator and will release the key. The free key can then be transferred to operate a parallel supply stream or an access interlock. The FS and Q locks are manufactured in brass or stainless steel.

OPERATION

The FS/Q switchgear interlocks are designed to control the operation of HV/LV switchgear.

FS/Q switchgear interlock

- 1** Key is trapped, HV/LV circuit is closed.



While the key is trapped, the isolator is closed providing the power supply.

- 2** Turn and release key to open the HV/LV circuit.

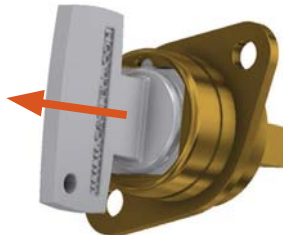

Turning the key opens the isolator. The key can then be released.

- 3** Key is free and the HV/LV circuit is open.



The free key can be used to operate either a parallel supply stream or an access interlock.



1SDC200039D0203_UL

SACE Emax 2 E2.2B-A/N-A • Orientable rear terminals (HR)

Size	Frame Amps	Int. Rating (kA@508V)	Withstand (kA)	Type	3 Poles		4 Poles		
					Global code		Global code		
E2.2B-A	1600	42	42	E2.2B-A 1600 Ekip Dip LI	1SDA077228R1		1SDA077398R1		
				E2.2B-A 1600 Ekip Dip LSI	1SDA077229R1		1SDA077399R1		
				E2.2B-A 1600 Ekip Dip LSIG	1SDA077230R1		1SDA077400R1		
				E2.2B-A 1600 Ekip Touch LI	1SDA077231R1		1SDA077401R1		
				E2.2B-A 1600 Ekip Touch LSI	1SDA077232R1		1SDA077402R1		
				E2.2B-A 1600 Ekip Touch LSIG	1SDA077233R1		1SDA077403R1		
				E2.2B-A 1600 Ekip Hi-Touch LSI	1SDA077235R1		1SDA077405R1		
				E2.2B-A 1600 Ekip Hi-Touch LSIG	1SDA077236R1		1SDA077406R1		
E2.2N-A	1600	50	50	E2.2N-A 1600 Ekip Dip LI	1SDA077278R1		1SDA077448R1		
				E2.2N-A 1600 Ekip Dip LSI	1SDA077279R1		1SDA077449R1		
				E2.2N-A 1600 Ekip Dip LSIG	1SDA077280R1		1SDA077450R1		
				E2.2N-A 1600 Ekip Touch LI	1SDA077281R1		1SDA077451R1		
				E2.2N-A 1600 Ekip Touch LSI	1SDA077282R1		1SDA077452R1		
				E2.2N-A 1600 Ekip Touch LSIG	1SDA077283R1		1SDA077453R1		
				E2.2N-A 1600 Ekip Hi-Touch LSI	1SDA077285R1		1SDA077455R1		
				E2.2N-A 1600 Ekip Hi-Touch LSIG	1SDA077286R1		1SDA077456R1		
		2000	50	50	E2.2N-A 2000 Ekip Dip LI	1SDA077288R1		1SDA077458R1	
					E2.2N-A 2000 Ekip Dip LSI	1SDA077289R1		1SDA077459R1	
					E2.2N-A 2000 Ekip Dip LSIG	1SDA077290R1		1SDA077460R1	
					E2.2N-A 2000 Ekip Touch LI	1SDA077291R1		1SDA077461R1	
					E2.2N-A 2000 Ekip Touch LSI	1SDA077292R1		1SDA077462R1	
					E2.2N-A 2000 Ekip Touch LSIG	1SDA077293R1		1SDA077463R1	
					E2.2N-A 2000 Ekip Hi-Touch LSI	1SDA077295R1		1SDA077465R1	
					E2.2N-A 2000 Ekip Hi-Touch LSIG	1SDA077296R1		1SDA077466R1	

Accessories

Electrical accessories



1SDC2005039F001



1SDC2005044F001



1SDC2005055F001



1SDC2005068F001



1SDC2005077F001



1SDC2006859F001



1SDC2006817F001

Open closed auxiliary contacts - AUX

Size	Type	Global code
E1.2 **	AUX 4Q (4 Form C) 400V E1.2	1SDA073750R1
E1.2	AUX 4Q (4 Form C) 24V E1.2	1SDA073751R1
E1.2	AUX 2Q (2 Form C) 400V + 2Q (2 Form C) 24V E1.2	1SDA073752R1
E2.2...E6.2 **	AUX 4Q (4 Form C) 400V E2.2...E6.2	1SDA073753R1
E2.2...E6.2	AUX 4Q (4 Form C) 24V E2.2...E6.2	1SDA073754R1
E2.2...E6.2	AUX 2Q (2 Form C) 400V + 2Q (2 Form C) 24V E2.2...E6.2	1SDA073755R1
E2.2...E6.2	AUX 6Q 400V E2.2...E6.2 ¹⁾	1SDA073756R1
E2.2...E6.2	AUX 6Q 24V E2.2...E6.2 ¹⁾	1SDA073757R1
E2.2...E6.2	AUX 3Q (3 Form C) 400V + 3Q (3 Form C) 24V E2.2...E6.2 ¹⁾	1SDA075973R1
E1.2	AUX 15Q (15 Form C) 400V E1.2 ^{2) *}	1SDA073758R1
E1.2	AUX 15Q (15 Form C) 24V E1.2 ^{2) *}	1SDA073759R1
E2.2...E6.2	AUX 15Q (15 Form C) 400V (for fixed/drawout with signalling in racked in) E2.2...E6.2 ^{2) *}	1SDA073760R1
E2.2...E6.2	AUX 15Q (15 Form C) 24V (for fixed/drawout with signalling in racked in) E2.2...E6.2 ^{2) *}	1SDA073761R1
E2.2...E6.2	AUX 15Q (15 Form C) 400V (for fixed/drawout with signalling in racked in/test isolated) E2.2...E6.2 ^{2) *}	1SDA073846R1
E2.2...E6.2	AUX 15Q (15 Form C) 24V (for fixed/drawout with signalling in racked in/test isolated) E2.2...E6.2 ^{2) *}	1SDA073847R1

1) AUX 6Q (6 Form C) is an alternative to the Ekip Signalling 4k module

2) Aux 15 Q (15 Form C) is an alternative to the Mechanical interlock (MI), the lock to prevent door opening when the circuit breaker is in the closed position (DLC) or the lock to prevent door opening when the circuit breaker is in the racked in or test position (DCP) when mounted on the right side. For E1.2 one of the mounting plates is also needed.

For E1.2 you need to order also one of the following items:

Plate for fixed - floor mounted 1SDA079783R1

Plate for fixed - wall mounted 1SDA079782R1

Plate for withdrawable 1SDA079784R1

* Not compatible with mechanical locks on compartment doors or mechanical interlocks

** Standard supply with automatic circuit-breakers

Auxiliary position contacts - AUP

Size	Type	Global code
E1.2	AUP 6 contacts 400V E1.2	1SDA073762R1
E1.2	AUP 6 contacts 24V E1.2	1SDA073763R1
E2.2...E6.2	AUP 5 contacts 400V E2.2...E6.2 - left set	1SDA080373R1
E2.2...E6.2	AUP 5 contacts 24V E2.2...E6.2 - left set	1SDA080374R1
E2.2...E6.2	AUP 5 suppl. contacts 400V E2.2...E6.2 - right set	1SDA080375R1
E2.2...E6.2	AUP 5 suppl. contacts 24V E2.2...E6.2 - right set	1SDA080376R1
E1.2...E6.2	AUP Ekip auxiliary position contact E1.2...E6.2	1SDA073768R1

Ready to close signalling contact - RTC

Size	Type	Global code
E1.2	RTC 250V E1.2	1SDA073770R1
E1.2	RTC 24V E1.2	1SDA073771R1
E1.2	RTC Ekip 24V E1.2	1SDA073772R1
E2.2...E6.2	RTC 250V E2.2...E6.2	1SDA073773R1
E2.2...E6.2	RTC 24V E2.2...E6.2	1SDA073774R1
E2.2...E6.2	RTC Ekip 24V E2.2...E6.2	1SDA073775R1

Trip signalling contact - S51 / bell alarm

Size	Type	Global code
E1.2	S51 / bell alarm 250V E1.2	1SDA073776R1
E1.2	S51 / bell alarm 24V E1.2	1SDA073777R1
E2.2...E6.2	S51 / bell alarm 250V E2.2...E6.2	1SDA073778R1
E2.2...E6.2	S51 / bell alarm 24V E2.2...E6.2	1SDA073779R1

Terminal blocks for auxiliary connection

Size	Type	Global code
E1.2...E6.2	Terminal blocks 10 pcs	1SDA073906R1

Accessories

Electrical accessories



1SDC200509F001



1SDC200504F001



1SDC200505F001



1SDC200506F001



1SDC200507F001



1SDC200685F001

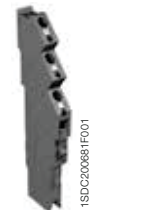

1SDC200681F001

Open closed auxiliary contacts - AUX

Size	Type	Global code
E1.2 **	AUX 4Q (4 Form C) 400V E1.2	1SDA073750R1
E1.2	AUX 4Q (4 Form C) 24V E1.2	1SDA073751R1
E1.2	AUX 2Q (2 Form C) 400V + 2Q (2 Form C) 24V E1.2	1SDA073752R1
E2.2...E6.2 **	AUX 4Q (4 Form C) 400V E2.2...E6.2	1SDA073753R1
E2.2...E6.2	AUX 4Q (4 Form C) 24V E2.2...E6.2	1SDA073754R1
E2.2...E6.2	AUX 2Q (2 Form C) 400V + 2Q (2 Form C) 24V E2.2...E6.2	1SDA073755R1
E2.2...E6.2	AUX 6Q 400V E2.2...E6.2 ¹⁾	1SDA073756R1
E2.2...E6.2	AUX 6Q 24V E2.2...E6.2 ¹⁾	1SDA073757R1
E2.2...E6.2	AUX 3Q (3 Form C) 400V + 3Q (3 Form C) 24V E2.2...E6.2 ¹⁾	1SDA075973R1
E1.2	AUX 15Q (15 Form C) 400V E1.2 ^{2) *}	1SDA073758R1
E1.2	AUX 15Q (15 Form C) 24V E1.2 ^{2) *}	1SDA073759R1
E2.2...E6.2	AUX 15Q (15 Form C) 400V (for fixed/drawout with signalling in racked in) E2.2...E6.2 ^{2) *}	1SDA073760R1
E2.2...E6.2	AUX 15Q (15 Form C) 24V (for fixed/drawout with signalling in racked in) E2.2...E6.2 ^{2) *}	1SDA073761R1
E2.2...E6.2	AUX 15Q (15 Form C) 400V (for fixed/drawout with signalling in racked in/test isolated) E2.2...E6.2 ^{2) *}	1SDA073846R1
E2.2...E6.2	AUX 15Q (15 Form C) 24V (for fixed/drawout with signalling in racked in/test isolated) E2.2...E6.2 ^{2) *}	1SDA073847R1

1) AUX 6Q (6 Form C) is an alternative to the Ekip Signalling 4k module

2) Aux 15 Q (15 Form C) is an alternative to the Mechanical interlock (MI), the lock to prevent door opening when the circuit breaker is in the closed position (DLC) or the lock to prevent door opening when the circuit breaker is in the racked in or test position (DCP) when mounted on the right side. For E1.2 one of the mounting plates is also needed.

For E1.2 you need to order also one of the following items:

Plate for fixed - floor mounted 1SDA079783R1

Plate for fixed - wall mounted 1SDA079782R1

Plate for withdrawable 1SDA079784R1

* Not compatible with mechanical locks on compartment doors or mechanical interlocks

** Standard supply with automatic circuit-breakers

Auxiliary position contacts - AUP

Size	Type	Global code
E1.2	AUP 6 contacts 400V E1.2	1SDA073762R1
E1.2	AUP 6 contacts 24V E1.2	1SDA073763R1
E2.2...E6.2	AUP 5 contacts 400V E2.2...E6.2 - left set	1SDA080373R1
E2.2...E6.2	AUP 5 contacts 24V E2.2...E6.2 - left set	1SDA080374R1
E2.2...E6.2	AUP 5 suppl. contacts 400V E2.2...E6.2 - right set	1SDA080375R1
E2.2...E6.2	AUP 5 suppl. contacts 24V E2.2...E6.2 - right set	1SDA080376R1
E1.2...E6.2	AUP Ekip auxiliary position contact E1.2...E6.2	1SDA073768R1

Ready to close signalling contact - RTC

Size	Type	Global code
E1.2	RTC 250V E1.2	1SDA073770R1
E1.2	RTC 24V E1.2	1SDA073771R1
E1.2	RTC Ekip 24V E1.2	1SDA073772R1
E2.2...E6.2	RTC 250V E2.2...E6.2	1SDA073773R1
E2.2...E6.2	RTC 24V E2.2...E6.2	1SDA073774R1
E2.2...E6.2	RTC Ekip 24V E2.2...E6.2	1SDA073775R1

Trip signalling contact - S51 / bell alarm

Size	Type	Global code
E1.2	S51 / bell alarm 250V E1.2	1SDA073776R1
E1.2	S51 / bell alarm 24V E1.2	1SDA073777R1
E2.2...E6.2	S51 / bell alarm 250V E2.2...E6.2	1SDA073778R1
E2.2...E6.2	S51 / bell alarm 24V E2.2...E6.2	1SDA073779R1

Terminal blocks for auxiliary connection

Size	Type	Global code
E1.2...E6.2	Terminal blocks 10 pcs	1SDA073906R1

Switch disconnectors

Fixed version



1SDC200665F001_LU

SACE Emax 2 E1.2 B-A/MS, N-A/MS • Front terminals (F)

Size	Frame Amps	Withstand (kA)	Type	3 Poles		4 Poles	
				Global code		Global code	
E1.2B-A/MS	800	42	E1.2B-A/MS 800	1SDA079548R1		1SDA079552R1	
	1200	42	E1.2B-A/MS 1200	1SDA079549R1		1SDA079553R1	
E1.2N-A/MS	800	50	E1.2N-A/MS 800	1SDA079550R1		1SDA079554R1	
	1200	50	E1.2N-A/MS 1200	1SDA079551R1		1SDA079555R1	



1SDC200670F001_LU

SACE Emax 2 E2.2 N-A/MS, S-A/MS, V-A/MS • Orientable rear terminals (HR)

Size	Frame Amps	Withstand (kA)	Type	3 Poles		4 Poles	
				Global code		Global code	
E2.2N-A/MS	1600	50	E2.2N-A/MS 1600	1SDA079570R1		1SDA079578R1	
	2000	50	E2.2N-A/MS 2000	1SDA079571R1		1SDA079579R1	
E2.2S-A/MS	800	65	E2.2S-A/MS 800	1SDA079564R1		1SDA079572R1	
	1600	65	E2.2S-A/MS 1600	1SDA079565R1		1SDA079573R1	
	2000	65	E2.2S-A/MS 2000	1SDA079566R1		1SDA079574R1	
E2.2V-A/MS	800	85	E2.2V-A/MS 800	1SDA079567R1		1SDA079575R1	
	1600	85	E2.2V-A/MS 1600	1SDA079568R1		1SDA079576R1	
	2000	85	E2.2V-A/MS 2000	1SDA079569R1		1SDA079577R1	



1SDC200671F001_LU

SACE Emax 2 E4.2 S-A/MS, V-A/MS, L-A/MS • Orientable rear terminals up to 2500A (HR)

Size	Frame Amps	Withstand (kA)	Type	3 Poles		4 Poles	
				Global code		Global code	
E4.2S-A/MS	2500	65	E4.2S-A/MS 2500	1SDA079596R1		1SDA079612R1	
	3200 (*)	65	E4.2S-A/MS 3200	1SDA079597R1		1SDA079613R1	
E4.2H-A/MS	2500	85	E4.2H-A/MS 2500	1SDA081867R1		1SDA081872R1	
	3200	85	E4.2H-A/MS 3200	1SDA081868R1		1SDA081873R1	
E4.2V-A/MS	800	100	E4.2V-A/MS 800	1SDA081864R1		1SDA081869R1	
	1600	100	E4.2V-A/MS 1600	1SDA081865R1		1SDA081870R1	
	2000	100	E4.2V-A/MS 2000	1SDA081866R1		1SDA081871R1	
	2500	100	E4.2V-A/MS 2500	1SDA079602R1		1SDA079618R1	
	3200 (*)	100	E4.2V-A/MS 3200	1SDA079603R1		1SDA079619R1	

* 3200A ratings only with rear vertical terminals

Accessories

Electrical accessories



First and second shunt coil - YO

Size	Type	Global code
E1.2..E6.2	YO E1.2..E6.2 24 VAC/DC	1SDA073668R1
E1.2..E6.2	YO E1.2..E6.2 30 VAC/DC	1SDA073669R1
E1.2..E6.2	YO E1.2..E6.2 48 VAC/DC	1SDA073670R1
E1.2..E6.2	YO E1.2..E6.2 60 VAC/DC	1SDA073671R1
E1.2..E6.2	YO E1.2..E6.2 110-120 VAC/DC	1SDA073672R1
E1.2..E6.2	YO E1.2..E6.2 120-127 VAC/DC	1SDA073673R1
E1.2..E6.2	YO E1.2..E6.2 220-240 VAC/DC	1SDA073674R1
E1.2..E6.2	YO E1.2..E6.2 240-250 VAC/DC	1SDA073675R1
E1.2..E6.2	YO E1.2..E6.2 277 VAC	1SDA073676R1
E1.2..E6.2	YO E1.2..E6.2 380-400 VAC	1SDA073677R1
E1.2..E6.2	YO E1.2..E6.2 415-440 VAC	1SDA073678R1
E1.2..E6.2	YO E1.2..E6.2 480-500 VAC	1SDA073679R1

Second shunt coils are an alternative to a UVR or anti-racking out device (fail safe)

First and second closing coil - YC

Size	Type	Global code
E1.2..E6.2	YC E1.2..E6.2 24 VAC/DC	1SDA073681R1
E1.2..E6.2	YC E1.2..E6.2 30 VAC/DC	1SDA073682R1
E1.2..E6.2	YC E1.2..E6.2 48 VAC/DC	1SDA073683R1
E1.2..E6.2	YC E1.2..E6.2 60 VAC/DC	1SDA073684R1
E1.2..E6.2	YC E1.2..E6.2 110-120 VAC/DC	1SDA073685R1
E1.2..E6.2	YC E1.2..E6.2 120-127 VAC/DC	1SDA073686R1
E1.2..E6.2	YC E1.2..E6.2 220-240 VAC/DC	1SDA073687R1
E1.2..E6.2	YC E1.2..E6.2 240-250 VAC/DC	1SDA073688R1
E1.2..E6.2	YC E1.2..E6.2 277 VAC	1SDA073689R1
E1.2..E6.2	YC E1.2..E6.2 380-400 VAC	1SDA073690R1
E1.2..E6.2	YC E1.2..E6.2 415-440 VAC	1SDA073691R1
E1.2..E6.2	YC E1.2..E6.2 480-500 VAC	1SDA073692R1

Shunt coil and closing coil test unit - YO/YC Test Unit (IEC only)

Size	Type	Global code
E1.2..E6.2	YO/YC test unit E1.2..E6.2	1SDA082751R1

Undervoltage coil - YU

Size	Type	Global code
E1.2..E6.2	YU E1.2..E6.2 24 VAC/DC	1SDA073694R1
E1.2..E6.2	YU E1.2..E6.2 30 VAC/DC	1SDA073695R1
E1.2..E6.2	YU E1.2..E6.2 48 VAC/DC	1SDA073696R1
E1.2..E6.2	YU E1.2..E6.2 60 VAC/DC	1SDA073697R1
E1.2..E6.2	YU E1.2..E6.2 110-120 VAC/DC	1SDA073698R1
E1.2..E6.2	YU E1.2..E6.2 120-127 VAC/DC	1SDA073699R1
E1.2..E6.2	YU E1.2..E6.2 220-240 VAC/DC	1SDA073700R1
E1.2..E6.2	YU E1.2..E6.2 240-250 VAC/DC	1SDA073701R1
E1.2..E6.2	YU E1.2..E6.2 277 VAC	1SDA073702R1
E1.2..E6.2	YU E1.2..E6.2 380-400 VAC	1SDA073703R1
E1.2..E6.2	YU E1.2..E6.2 415-440 VAC	1SDA073704R1
E1.2..E6.2	YU E1.2..E6.2 440-500 VAC	1SDA073705R1

The undervoltage coil is an alternative to a second shunt coil or anti-racking out device (fail safe)

Electronic time-delay device for undervoltage coil - UVD (IEC only)

Size	Type	Global code
E1.2..E6.2	24-30 VDC	1SDA038316R1
E1.2..E6.2	48 VAC/DC	1SDA038317R1
E1.2..E6.2	60 VAC/DC	1SDA038318R1
E1.2..E6.2	110...127 VAC/DC	1SDA038319R1
E1.2..E6.2	220...250 VAC/DC	1SDA038320R1

The electronic time-delay device must be used with an undervoltage coil with the same voltage

THIS DRAWING PREPARED FOR:

CARTER MACHINERY CO, INC
NOVAVAX SENECA MEADOWS QC
GERMANTOWN, MD

THIS DRAWING PREPARED BY:

HYDRO
REDD Team
Delhi, Louisiana
1-800-779-5509

PRODUCT REQUESTED:
ALUMINUM STAIR SYSTEM
WITH 38" HIGH TWO LINE RAILS

CONTRACTOR/PURCHASER IS RESPONSIBLE FOR VERIFYING LAYOUT AS WELL AS ANY CRITICAL DIMENSIONS & THRESHOLD ELEVATIONS PRIOR TO FABRICATION.
A SIGNED AND DATED APPROVAL IS REQUIRED TO BEGIN PRODUCTION.

BY SIGNING BELOW, I ACKNOWLEDGE THAT I HAVE REVIEWED ALL CRITICAL INFORMATION THAT IS LISTED WITHIN THIS DOCUMENT AND ASSUME RESPONSIBILITY FOR ANY VARIANCES ON SITE.

DATE _____
SIGNATURE _____

GENERAL NOTES:

1. ALUMINUM LANDING AND STAIR SECTIONS SHALL BE A RIGID, FREE-SPAN DESIGN.
2. DESIGN OF THE ALUMINUM STRUCTURES SHALL CONFORM TO THE CURRENT EDITION OF THE **ALUMINUM ASSOCIATION SPECIFICATIONS AND GUIDELINES FOR ALUMINUM STRUCTURES**.
3. ALL ALUMINUM CONSTRUCTION USING 6000 SERIES ALUMINUM ALLOYS. STRUCTURAL MEMBERS TO BE 6061-T6, 6063-T6 AND 6005-T5 ALUMINUM ALLOY.
4. ALUMINUM WILL BE STANDARD MILL FINISH UNLESS OTHERWISE NOTED.
5. WELDING SHALL BE IN ACCORDANCE WITH ANSI/AWS D1.2/D1.2M-2014 GAS METAL ARC WELDING (GMAW) PROCESS BY EXPERIENCED OPERATORS.
6. ALL FASTENERS TO BE 18-8 (SERIES 304) STAINLESS STEEL UNLESS OTHERWISE NOTED.
7. LANDING AND STAIR SECTIONS ARE TO BE ENGINEERED FOR A 100 PSF LIVE LOAD.
8. LANDING WALKING SURFACES SHALL BE DESIGNED FOR A MINIMUM CONCENTRATED VERTICAL LOAD OF 300 LBS APPLIED EVENLY OVER A 12" x 12" AREA. STAIR TREADS SHALL BE DESIGNED TO WITHSTAND A MINIMUM CONCENTRATED LOAD OF 300 LBS OVER A 4 SQUARE INCH AREA.
9. LANDING GUARDRAILS TO BE 42 INCH MINIMUM HEIGHT UNLESS OTHERWISE SPECIFIED.
10. HANDRAIL ASSEMBLIES AND GUARDRAILS SHALL BE DESIGNED TO RESIST A LOAD OF 50 PLF APPLIED IN ANY DIRECTION AT THE TOP OF THE RAIL.
11. HANDRAIL ASSEMBLIES AND GUARDRAILS SHALL BE ABLE TO RESIST A SINGLE CONCENTRATED LOAD OF 200 LBS, APPLIED IN ANY DIRECTION AT ANY POINT ALONG THE TOP OF THE RAIL. THIS LOAD NEED NOT BE ASSUMED TO ACT CONCURRENTLY WITH THE LOADS SPECIFIED IN THE PRECEDING PARAGRAPH.
12. INTERMEDIATE RAILS (ALL THOSE EXCEPT HANDRAILS), BALUSTERS AND PANEL FILLERS SHALL BE DESIGNED TO WITHSTAND A HORIZONTALLY APPLIED NORMAL LOAD OF 50 LBS ON AN AREA EQUAL TO 1 SQUARE FOOT, INCLUDING OPENINGS AND SPACE BETWEEN RAILS.
13. DECK SURFACE SHALL BE A SLIP RESISTANT, EXTRUDED ALUMINUM DECKING WITH A TRIPLE I-BEAM, SELF-MATING DESIGN.
14. ALL SURFACES, MEMBERS AND THEIR WELDED JOINTS SHALL BE SMOOTH AND FREE FROM SHARP OR JAGGED EDGES.
15. ALL DESIGNS SHOWN HEREIN ARE SUBJECT TO CHANGE PENDING FIELD VERIFICATION OF EXISTING CONDITIONS.
16. CONCEALED AND UNEXPOSED SURFACES: WILL NOT BE CLEANED NOR DEBURRED. EXCEPTION (WHEN REQUESTED): UNDERSIDE OF PLATFORMS EXCEEDING 60" IN ELEVATION.
17. ANCHORING OF PRODUCT TO GRADE BY OTHERS

Hydro Aluminum Structures, Inc. is an Equal Opportunity Employer. Minorities and women are encouraged to apply. Hydro Aluminum Structures, Inc. is an Equal Opportunity Employer. Minorities and women are encouraged to apply.

HYDRO
18007 79-5509
Delhi, LA 71232
Phone: 1 (800) 779-5509
Fax: 1 (800) 844-1500



FOR QUOTATION
PURPOSES ONLY

CARTER MACHINERY CO., INC
GERMANTOWN, MD
ALUMINUM ACCESS STAIR SYSTEM
WITH 38" HIGH TWO LINE GUARDRAIL

DATE 7/12/2022

BY NOVAVAX

PROJECT Carter W022320

REV R - 0

DESIGNED BY TMB

APPROVED BY

SHEET NUMBER COVER

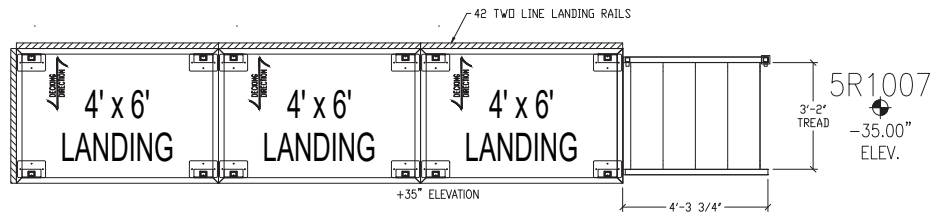

38 TWO LINE STAIR ACCESS PLAN VIEW
(QTY x 2)

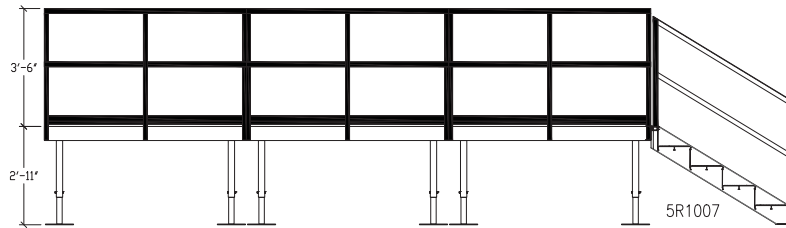

38 TWO LINE STAIR ACCESS ELEVATION VIEW

Hydro is a registered trademark of Hydro
Inc. All other trademarks are the property of
their respective owners. Hydro is not
responsible for any unauthorized use.

HYDRO
18000 Mid-Loop
Doriv, LA 71222
Phone: 1 (800) 776-5099
Fax: 1 (800) 842-1000



FOR QUOTATION
PURPOSES ONLY

CARTER MACHINERY CO., INC.
GERMANTOWN, MD
ALUMINUM ACCESS STAIR SYSTEM
WITH 38" HIGH TWO LINE GUARDRAIL

DATE: 7/12/2022
BY: NCWJAX
PROJECT: Carter W022320
REV: R - 0
DRAWN BY: TMB
CHECKED BY:

SHEET NUMBER
01