C13GC - 400kw Submittal-00

Date:	5/14/2026
Project:	Midwest Engines and Generators
Contractor/Installer:	
End User:	Midwest Engines and Generators
Address:	Midwest Engines and Generators TBD
Job ID:	
Submittal ID:	TES-001267
Notes	Estimated DRY Weight Includes: Gen - Enc = 10,580 lbs.
Prepared By:	
Project Manager:	
Prepared For: Salesman	

Table of Contents

Section

Sub-Section

SECTION -1

Bill of Material

Submittal Approval Page

Table of Contents

SECTION -2

D400 (G13GC) 400kw

Permanent Magnet Generator

Generator Space Heater

ADEM A4 Engine Controller

PL444 - Telematics Hardware

Generator Data Sheet

Performance Data Sheet

Sound Attenuated Enclosure

Integral Fuel Tank

5 Gallon Spill Containment Box

Fuel Dip Chart

GCCP 1.2 Control Panel

Remote Annunciator

Remote Annunciator Drawings

Circuit Breakers

100A Load Center

LED Lights

GFCI Receptacles

Remote E-Stop Button

Jacket Water Heater

Battery Charger

CAT Batteries

Generator - 400kw

SECTION -3

Drawings & Warranty Info

CAT Drawings

Electrical Stub-up Drawing

Door Swing Drawing

Right Side Drawing

Wire Pull Drawing

CAT Schematics

Concrete Pad Recommendation

Extended Service Coverage (ESC)

UL Product

IBC Certificate

CAT Warranty Statement

BILL of MATERIAL

Midwest Engines and Generators
C13GC - 400kw



Caterpillar Components:

Features

Feature	Qty	Description
CERTESE_I	1	EPA STATIONARY EMERGENCY
60H0480_I	1	60HZ 480 VOLT (WYE)
STANDBY_I	1	STANDBY POWER
KW00400_I	1	400ekW, 60Hz, 1800rpm
C13DE4B_I	1	C13 D400GC PGS PSB
ULLIST_I	1	UL 2200 LISTED PACKAGE GEN SET
IBCSCCB_I	1	IBC SEISMIC CERT OF COMPLIANCE
LANENGO_I	1	ENGLISH INSTRUCTION LANGUAGE
ADEMA4_I	1	ADEMA4 GOVERNOR
MSEPGGN_I	1	GENERAL EPG
MSCEC84_I	1	HEALTHCARE (NON DATACENTERS)

MWCODEG_I	1	EMERGENCY STANDBY POWER
PMEXCI3_I	1	PERMANENT MAGNET GENERATOR
SHK0012_I	1	SPACE HEATER 12
OGNSEMR_I	1	M3134L41, 60HZ, SE, ALT MR
FULLPWR_I	1	FULL POWER
BATDS03_I	1	BATTERY DISCONNECT SWITCH
FTDW036_I	1	C13 INTEGRAL TANK (24HR)UL142
FSCO5G_I	1	5 GALLON SPILL CONTAINMENT
FAHL90_I	1	AUDIO & FUEL ALARM (90% LEVEL)
ENC SAR3_I	1	C13 SALVL 2 (WHITE) w/MUFFLER
ELACDC1_I	1	ENCLOSURE LIGHTS
GCCP12U_I	1	CONTROL PANEL DEESEA6310
NFPA01_I	1	NFPA BUNDLE
EMCCAS5_I	1	GEN RUNNING & FAULT RELAY
PAA1_I	1	PANEL MOUNTED AUDIBLE ALARM
LDC100A_I	1	100A LOAD CENTER
GFCICS1_I	1	20A GFCI (CONTROLS SIDE)
CSB2_I	1	EXTERNAL EMERGENCY STOP
BAT2462_I	1	1000CCA WET BAT 90VHR INSTAL
BTC1028_I	1	BATTERY CHARGER 10 AMP
WHHH01_I	1	JACKET WATER HTR (PUMP STYLE)
CT0805A_I	1	800:5 CT RATIO
CBK0702_I	1	800A LSI SINGLE MANUAL CB
NO2NDCB_I	1	NO 2ND CIRCUIT BREAKER
NOSUSE_I	1	NO SUSE DECALS & FILMS
NTS800_I	1	NEUTRAL BAR 800A
STD RAD_I	1	STANDARD RADIATOR
EMGSTP1_S	1	REMOTE E-STOP BUTTON
ANNR01_S	1	REMOTE ANNUNCIATOR (GCCP)
PL444_I	1	PRODUCT LINK 4G LTE TELEMATICS
AM_I	1	AMERICAS BAND
TCVYES_I	1	ACCEPT - REVIEW LINK IN DESC
STDTEST_I	1	STD TEST - PKG GEN SET 0.8 PF

Submittal Approval Page

To approve the Midwest Engines and Generators 400kw Submittal-00

Please check the box, add signature, and the date.

<input type="checkbox"/> APPROVED AS SUBMITTED <input type="checkbox"/> APPROVED WITH CHANGES NOTED _____ Signature _____ Date	ENGINEER'S NOTES AND COMMENTS
---	-------------------------------

Cat® D400 GC

Diesel Generator Sets



Standby : 60 Hz



Image shown may not reflect actual configuration

Engine Model	Cat® C13 In-line 6, 4-cycle Diesel
Bore x Stroke	130 mm x 157 mm (5.1 in x 6.2 in)
Displacement	12.5 L (763 in³)
Compression Ratio	16.3:1
Aspiration	Turbocharged Air-to-Air Aftercooled
Fuel Injection System	MEUI
Governor	Electronic ADEM™ A4 - G2 Class* capable

Model	Standby	Emission Strategy
D400 GC	400 kW, 500 kVA	EPA Certified for Stationary Emergency Application

PACKAGE PERFORMANCE

Performance	Standby
Frequency	60 Hz
Genset Power Rating	500 kVA
Genset power rating with fan @ 0.8 power factor	400 kW
Emissions	EPA TIER 3
Performance Number	EM1694
Fuel Consumption	
100% load with fan, L/hr (gal/hr)	105.8 (27.9)
75% load with fan, L/hr (gal/hr)	90.7 (24.0)
50% load with fan, L/hr (gal/hr)	66.2 (17.5)
25% load with fan, L/hr (gal/hr)	37.7 (10.0)
Cooling System ¹	
Radiator air flow restriction (system), kPa (in. water)	0.12 (0.48)
Radiator air flow, m³/min (CFM)	398 (14055)
Engine coolant capacity, L (gal)	66.2 (17.5)
Radiator coolant capacity, L (gal)	37.7 (10)
Total coolant capacity, L (gal)	104 (27.5)
Inlet Air	
Combustion air inlet flow rate, m³/min (CFM)	24.4 (862)
Max. Allowable Combustion Air Inlet Temp, °C (°F)	47 (116)
Exhaust System	
Exhaust stack gas temperature, °C (°F)	567 (1053)
Exhaust gas flow rate, m³/min (CFM)	82 (2896)
Exhaust system backpressure (maximum allowable) kPa (in. water)	10 (40)
Heat Rejection	
Heat rejection to jacket water, kW (BTU/min)	156 (8871)
Heat rejection to exhaust (total), kW (BTU/min)	398 (22634)
Heat rejection to aftercooler, kW (BTU/min)	71 (4037)
Heat rejection to atmosphere from engine, kW (BTU/min)	52 (2957)
Heat rejection from alternator, kW (BTU/min)	29 (1649)
Emissions (Nominal) ²	
NOx, mg/Nm³ (g/hp-hr)	2274.7 (4.58)
CO, mg/Nm³ (g/hp-hr)	666.9 (1.35)
HC, mg/Nm³ (g/hp-hr)	6.2 (0.01)
PM, mg/Nm³ (g/hp-hr)	39.4 (0.10)

D400 GC Diesel Generator Sets

Electric Power



Alternator ³		
Voltages	480V	600V
Motor starting capability @ 30% Voltage Dip, skVA	871	731
Current, Amps	601.4	481.1
Frame Size	M3134L4	M3115L4
Excitation	S.E	AREP
Temperature Rise, °C	105	130

WEIGHTS & DIMENSIONS – OPEN SET

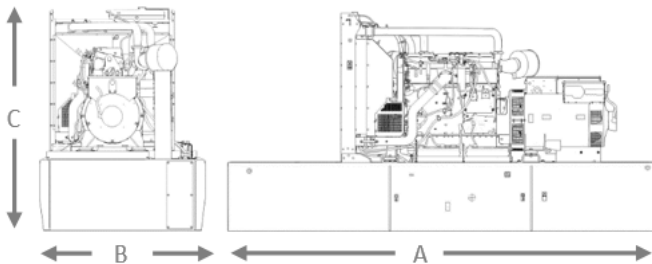

FUEL TANK CAPACITY

Tank Design	Total Capacity L (gal)	Useable Capacity L (gal)
Integral	2820 (744.9)	2553 (674.4)

Base	Length "A" mm (in)	Width "B" mm (in)	Height "C" mm (in)	Generator Set Weight kg (lb)
Skid (Wide Base)	4625 (182.8)	1630 (64.2)	2039 (80.3)	3325 (7330.4)
Integral Tank Base	4625 (182.8)	1630 (64.2)	2456 (96.7)	4107 (9054.4)

Note: General configuration not to be used for installation. See general dimension drawings for detail.

APPLICABLE CODES AND STANDARDS:

CSA C22.2 No 100-04, UL142, UL489, UL869, cUL/UL2200, NFPA 37, NFPA 70, NFPA 99, NFPA 110, IBC, IEC60034-1, ISO 3046, ISO 8528, NEMA MG 1-33.

Note: Codes may not be available in all model configurations. Please consult your local Cat Dealer representative for availability.

STANDBY: Output available with varying load for the duration of the interruption of the normal source power. Average power output is 70% of the standby power rating. Typical operation is 200 hours per year, with maximum expected usage of 500 hours per year.

RATINGS: Ratings are based on SAE J1349 standard conditions. These ratings also apply at ISO3046 standard conditions.

FUEL RATES: Based on fuel oil of 35° API [16° C (60° F)] gravity having an LHV of 42 780 kJ/kg (18,390 Btu/lb) when used at 29° C (85° F) and weighing 838.9 g/litre (7.001 lbs/U.S. gal.). Additional ratings may be available for specific customer requirements, contact your Caterpillar representative for details. For information regarding Low Sulfur fuel and Biodiesel capability, please consult your Cat dealer.

DEFINITIONS AND CONDITIONS

¹ For ambient and altitude capabilities consult your Cat dealer. Air flow restriction (system) is added to existing restriction from factory.

² Emissions data measurement procedures are consistent with those described in EPA CFR 40 Part 89, Subpart D & E and ISO8178-1 for measuring HC, CO, PM, NOx. Data shown is based on steady state operating conditions of 77° F, 28.42 in HG and number 2 diesel fuel with 35° API and LHV of 18,390 BTU/lb. The nominal emissions data shown is subject to instrumentation, measurement, facility and engine to engine variations. Emissions data is based on 100% load and thus cannot be used to compare to EPA regulations which use values based on a weighted cycle.

³ UL 2200 Listed packages may have oversized generators with a different temperature rise and motor starting characteristics. Generator temperature rise is based on a 40° C ambient per NEMA MG1-32.

* Governing Class capability as per ISO8528-5. Consult your local Cat dealer for configuration and site specific transient performance classification.

www.cat.com/electricpower

©2025 Caterpillar
All rights reserved.

Materials and specifications are subject to change without notice.

The International System of Units (SI) is used in this publication. CAT, CATERPILLAR, LET'S DO THE WORK, their respective logos, "Caterpillar Corporate Yellow", the "Power Edge" and Cat "Modern Hex" trade dress as well as corporate and product identity used herein, are trademarks of Caterpillar and may not be used without permission.

Permanent Magnet Excitation



Block Diagram of Diesel Generator set using Permanent Magnet Generator (PMG) excitation system

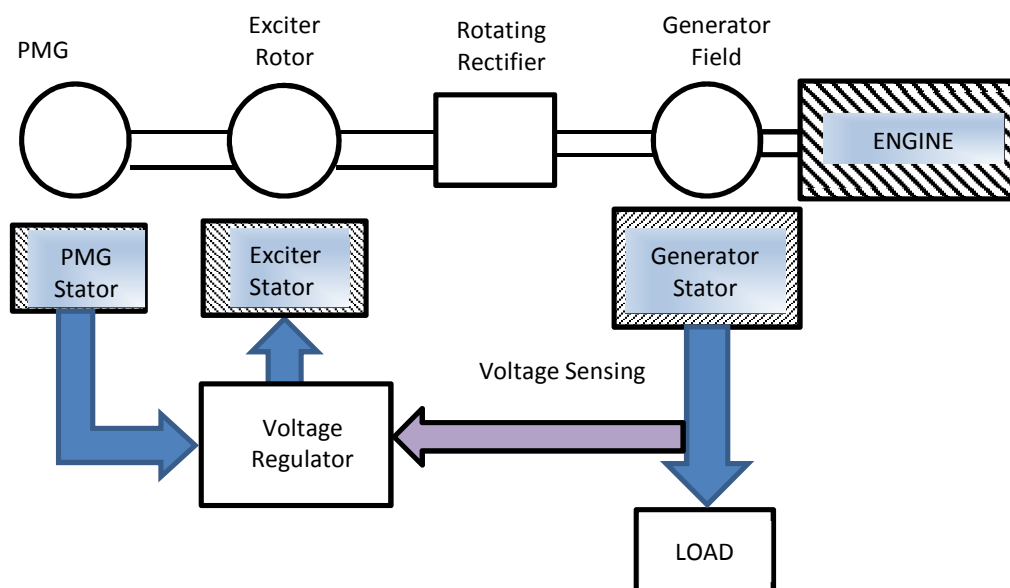

In Diesel generator sets employing PMG excitation system a small permanent magnet generator (PMG) is attached to the same shaft as the main generator at the non-drive end. The PMG stator produces clean power source for the voltage regulator.

The PMG excitation system can be retrofittable on most alternators. It has the following benefits over a self-excitation system.

1. Provides reliable, isolated power which is independent of the generator output
2. Ability to provide sustained short circuit current (up to 3 times the rated current) during fault conditions and allows breaker discrimination.
3. Provides clean and uninterrupted power to the voltage regulator even when the diesel generator set is supplying non-linear or harmonic loads.
4. Can provide reduced transient voltage dip on motor starting compared to a self-excited diesel generator set.

The PMG excitation system is offered as an option on Caterpillar C3.3 to C18 gensets as shown in the table below. The use of PMG excitation system may require an upgrade to the voltage regulator and alternator.

Alternator Frame	Engine Model
LC Frame	C3.3 – C18
A Frame	C9 – C18

GENERATOR SPACE HEATER



Generator Space Heater

for C13/C15/C18

Picture shown may not reflect actual configuration

GENERAL DESCRIPTION

Humidity is a natural enemy of generators and all electrical equipment.

Space heaters are design to protect generator windings from abnormally high humidity conditions when the generator is idle. The heater maintains the air around the windings at a suitable temperature to prevent winding corrosion due to condensation

Generator space heaters are electrical resistance heater and located within the generator stator housing. Space heaters are particularly recommended for generating located in a low ambient and/or high humidity environment. As a further benefit, space heaters provide an excellent method of drying out a generator after long transit or storage.

Because space heaters are required only during non-operative periods, they are require availability of a power source separate from the generator itself.

When the generating set is not running the heater is automatically connected to the AC supply through a power relay mounted in the control panel. Upon receiving a start signal the AC supply is automatically disconnected by the power relay and automatically reconnected when the start signal is removed.

The space heater for C13/C15/C18 generator sets uses one heating element. Heater element electrical data: Voltage - 120V/230V, Power - 150W / 250W*.

All space heaters are designed for 120 / 230 Volt operation (50 or 60 Hz) by making series connections at the terminal strip.

Space Heaters Connection Diagram

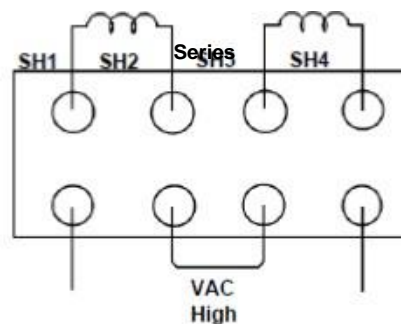

* for North American Region

LEHE1885-00 (02-19)

www.Cat.com/electricpower

©2019 Caterpillar All rights reserved. Materials and specifications are subject to change without notice. The International System of Units (SI) is used in this publication. CAT, CATERPILLAR, their respective logos, "Caterpillar Yellow", the "Power Edge" and Cat "Modern Hex" trade dress as well as corporate and product identity used herein, are trademarks of Caterpillar and may not be used without permission.



ADEM™ A4 Engine Controller

The ADEM™ A4 is the main Electronic Control Module (ECM) used on select diesel engines. The ADEM A4 provides a higher degree of control over a large number of combustion variables. The ADEM A4 is designed to control/interface Electronic Unit Injector (EUI) equipped engines. The ADEM A4 engine system is composed of the ADEM A4 ECM, control software, sensors, actuators, fuel injectors, and interface to the generator system. The prime benefit of an ADEM A4 engine system is to better control and maintain the particulate emissions, both steady state and transient, while improving engine performance.

Features

Reliable, Durable

All ADEM A4 controllers are designed to survive the harshest environments.

- Environmentally sealed, die-cast aluminum housing isolates and protects electronic components from moisture and dirt contamination
- Rigorous vibration testing ensures product reliability and durability
- Accuracy maintained from -40°C to 85°C
- Electrical noise immunity to 100 volts / meter
- Internal circuits are designed to withstand shorts to + battery and – battery

Simple Servicing

Each ADEM A4 system works in combination with the Cat® ET service tool software to keep the engine operating at peak performance.

- Displays measured parameters
- Retrieves active and logged event code documenting abnormal system operation
- Performs calibrations and diagnostic tests
- Supports flash programming of new software into the ADEM A4 ECM

Self Diagnostics

Each ADEM A4 ECM has a full compliment of diagnostics. The ECM can detect faults in the electrical system and report those faults to the service technician for quick repair.

- Self-diagnostic capability pinpoints operational problems in need of attention.

Advanced Features

- Enhanced performance from fuel injection timing and limiting
- Adjustable monitoring of vital engine parameters
- Programmable speed acceleration ramp rate
- Data link interfaces

Description

The ECM is housed in an environmentally sealed cast-ing. All wiring connections to the ECM are made using two sealed connectors: a single seventy-pin connector and a single one hundred twenty-pin connector.

Engine Speed Governing

Desired engine speed is calculated by the ECM and held within ± 0.2 Hz for isochronous and droop mode. The ECM accounts for droop that is requested. The proper amount of fuel is sent to the injectors due to these calculations. The ECM also employs cooldown/shutdown strategies, acceleration delays on startup, acceleration ramp times and speed reference.

Fuel Limiting

Warm and cold fuel-air ratio control limits are controlled by the ECM. Electronic monitoring system derates, torque limit, and cranking limit, programmable torque scaling, and cold cylinder cutout mode are standard features.

Fuel Injection Timing

Master timing for injection is controlled by the ECM control. Temperature dependencies are accounted for in the fuel injection calculations.

Electronic Monitoring

Electronic monitoring of vital engine parameters can be programmed. Warning, derate, and shutdown event conditions may be customized by the user.

Information Management

The ECM stores information to assist with electronic troubleshooting. Active and logged diagnostic codes, active events, logged events, fuel consumption, engine hours, and instantaneous totals aid service technicians when diagnosing electronic faults and scheduling preventive maintenance.

Calibrations

Engine performance is optimized through injection timing. Auto/manual sensor calibrations are standard features.

On-Board System Tests

System tests are available to assist in electronic troubleshooting. These tests include: injector activation, injector cutout, and override of control outputs.

Data Link Interfaces

The ADEM A4 communicates with the EMCP via a dedicated communication network.

Electronic Sensing

The following sensing is available on the ADEM A4: oil pressure, fuel pressure, fuel temperature, atmospheric pressure, air inlet temperature, turbo outlet pressure, engine coolant temperature, engine speed, throttle, position, exhaust temperature, oil filter pressure differential, fuel filter pressure differential, air filter pressure differential and crankcase pressure.

SPECIFICATIONS

Impervious to:

Salt spray, fuel, oil and oil additives, coolant, spray cleaners, chlorinated solvents, hydrogen sulfide and methane gas, and dust.

Input and output protection

All inputs and outputs are protected against short circuits to +battery and –battery

Input voltage range (24 VDC nominal)

18 to 32 VDC

Mounting

Engine mounted

Reverse polarity protected

Shock, withstands 20g

Temperature range

Operating: –40°C to 85°C (–40°F to 185°F)

Storage: –50°C to 120°C (–58°F to 248°F)

Vibration

Withstands 8.0g @ 24 to 2 kHz

Information contained in this publication may be considered confidential. Discretion is recommended when distributing.

Materials and specifications are subject to change without notice.

CAT, CATERPILLAR, LET'S DO THE WORK, their respective logos, "Caterpillar Yellow," the "Power Edge" and Cat "Modern Hex" trade dress as well as corporate and product identity used herein, are trademarks of Caterpillar and may not be used without permission.

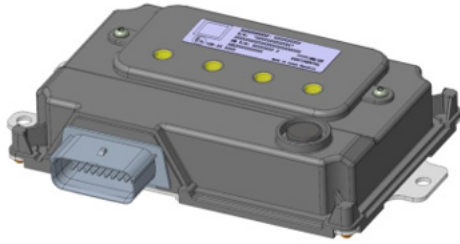

Cat® PL444 4G LTE Radio (Model: PL444 NA) Telematics Hardware

Product Description

The Caterpillar PL444 system is a Telematics product that is designed to record and store data from multiple datalinks (CAN J1939, Modbus RS485) present on higher level systems, then transmit the data offboard via wireless communications (cellular) to back office systems for end customer use.

Features

Design Specifications:

- 4G LTE Category 4 Radio
- GNSS signal tracking

- CAN datalink communication
- Modbus datalink communication
- Durable IP66/67-rated enclosure

Radio Connections / Pinout

	A	B	C	D	E	F	G	K	L	M
1	CAN_H	CAN_L	Not used	Not used	Not used	Not used	Not used	Not used	KSW	Batt+
2	Not used	Not used	Not used	Not used	Not used	Not used	Not used	Wireless Disable	Not used	Batt-
3	RS485 RTN	Not used	Not used	Not used	Not used	Not used	LSD1	Not used	Not used	Not used
4	RS485_A	RS485_B	Not used	Not used	Not used	Not used	Not used	Not used	Not used	Not used

- CAN_H: CAN High
- CAN_L: CAN Low
- KSW: Keyswitch (Ignition) – Wakes the device up when tied to Batt+ voltage
- Batt+: 12/24V Input
- Batt-: Ground/Return
- Wireless Disable: When pulled to ground, disables all RF transmissions (Cellular)
- LSD1/2: Low Side Drivers 1 and 2. Connects a load with a voltage source, to ground when enabled, completing the circuit
- RS485 RTN: RS-485 Shield
- RS485A/B: RS-485 Modbus connections

Radio Dimensions

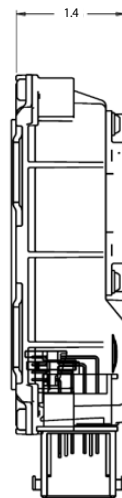
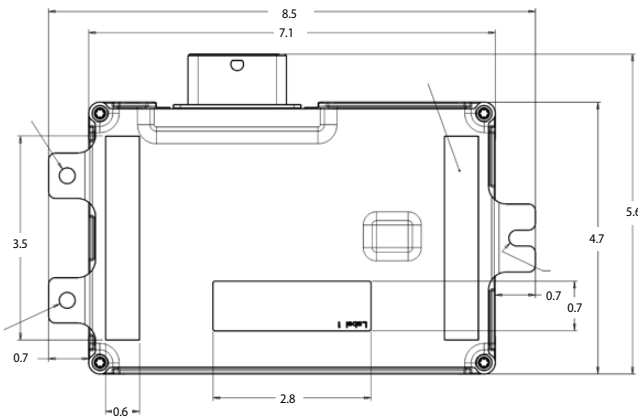

*All dimensions are in inches.

Technical Specifications

Input Voltage

Voltage Range 9 to 32V DC
 Protection Reverse polarity

Current Consumption

Idle Current (non-transmitting)..... < 300 mA
 Peak Current < 6A
 Sleep Current <3 mA

Physical Specifications

Enclosure Material..... Plastic (PBT+ASA GF30 FR)
 Aluminum (AlMg2.5 / H22; H23)
 Dimensions (in)..... 8.5 x 5.6 x 1.4
 Weight 0.45 kg
 Interface Connectors 48 pin Molex

Environment

Operating/Storage Temp -40°C to +85°C
 Ingress Protection..... IP66/67
 Humidity..... SAE J1455
 Vibration 9.8 Grms random (24-2000 Hz), up to 0.5 g²/Hz

Regulatory Compliance

FCC, IC, CE RED, EN/UL/CSA 62368-1, RoHS, WEEE, REACH

LEDs

Orange GNSS (Solid: GNSS Fix, 1Hz: Searching/no lock, Off: Fault)
 Blue Datalink (Flashing: Activity on J1939 or Modbus Off: Fault or No Connection)
 Yellow Cellular (Solid: Data connection established, Flashing: Searching for signal, Off: Modem off or Fault)
 White Bluetooth® (Solid: Connection established, Flashing: Advertising mode, Off: Bluetooth off or Fault)

Secure Key Injection

Security..... Unique and cryptographic identity

Communications

Datalink J1939/CAN
 Datalink..... Modbus (RS-485)
 Wireless..... 4G LTE with 2G/3G fallback
 Wireless Bluetooth®/BLE 5.0

I/O

Low Side Drivers (300 mA max).....2
 Switch to Ground1
 Keyswitch1

Positioning (GNSS)

Signal TrackingGPS/Galileo/GLONASS/BeiDou
 AntennaInternal

Cellular Communications

LTE Bands/Frequencies

Band	Frequencies (Uplink / Downlink) (MHz)
2	1850-1910 / 1930-1990
4	1710-1755 / 2110-2155
5	824-849 / 869-894
7	2500-2570 / 2620-2690
12/17	699-716 / 729-746
13	777-787 / 746-756

3G (UMTS) Bands/Frequencies

Band	Frequencies (Uplink / Downlink) (MHz)
2	1850-1910 / 1930-1990
4	1710-1755 / 2110-2155
5	824-849 / 869-894

2G (GSM) Bands/Frequencies

Band	Frequencies (Uplink / Downlink) (MHz)
2	1850-1910 / 1930-1990
5	824-849 / 869-894

Antennas 2x internal (Primary + Diversity) to support 2x2 MIMO

SIM eUICC chip
 Operating Temperature..... -30°C to +70°C

Bluetooth® Communications

Frequencies..... 2402 – 2480 MHz
 Version..... BLE 5.0
 Antennainternal

LET'S DO THE WORK.™

www.cat.com/electricpower
 ©2021 Caterpillar
 All rights reserved.

Materials and specifications are subject to change without notice.

The International System of Units (SI) is used in this publication. CAT, CATERPILLAR, LET'S DO THE WORK, their respective logos, "Caterpillar Corporate Yellow" the "Power Edge" and Cat "Modern Hex" trade dress as well as corporate and product identity used herein, are trademarks of Caterpillar and may not be used without permission.

[Spec Info](#) [Mechanical Data](#) [Cooling Data](#) [Motor Starting Curve](#) [Open Circuit Curve](#)
[Zero Power Factor Curve](#) [Reactive Capability Chart](#) [General Information](#)

Selected Model

Engine: C13 **Generator Frame:** M3134L41 **Genset Rating (kW):** 400.0 **Line Voltage:** 480
Fuel: Diesel **Generator Arrangement:** 6263795 **Genset Rating (kVA):** 500.0 **Phase Voltage:** 277
Frequency: 60 **Excitation Type:** Self Excited **Pwr. Factor:** 0.8 **Rated Current:** 601.4
Duty: STANDBY **Connection:** - STAR **Application:** EPG **Status:** Current
Version: 42423 /44804 /43655 /11990

Spec Information

Generator Specification		Generator Efficiency			
Frame: M3134L41	Type: SR500	No. of Bearings: 1	Per Unit Load	kW	Efficiency %
Winding Type: RANDOM WOUND	Flywheel: 14		0.25	100	91.4
Connection: -STAR	Housing: 1		0.5	200	94.1
Phases: 3	No. of Leads: 6		0.75	300	94.8
Poles: 4	Wires per Lead: 0		1	400	94.8
Sync Speed: 1800	Generator Pitch: 0.6667				
Reactances		Per Unit	Ohms		
SUBTRANSIENT - DIRECT AXIS X'' _d		0.0977	0.0450		
SUBTRANSIENT - QUADRATURE AXIS X'' _q		0.1248	0.0575		
TRANSIENT - SATURATED X' _d		0.1395	0.0643		
SYNCHRONOUS - DIRECT AXIS X _d		2.7669	1.2750		
SYNCHRONOUS - QUADRATURE AXIS X _q		1.4112	0.6503		
NEGATIVE SEQUENCE X ₂		0.1113	0.0513		
ZERO SEQUENCE X ₀		0.0056	0.0026		
Time Constants		Seconds			
OPEN CIRCUIT TRANSIENT - DIRECT AXIS T' _{d0}		1.9823			
SHORT CIRCUIT TRANSIENT - DIRECT AXIS T' _d		0.1000			
OPEN CIRCUIT SUBTRANSIENT - DIRECT AXIS T'' _{d0}		0.0142			
SHORT CIRCUIT SUBTRANSIENT - DIRECT AXIS T'' _d		0.0100			
OPEN CIRCUIT SUBTRANSIENT - QUADRATURE AXIS T'' _{q0}		0.1130			
SHORT CIRCUIT SUBTRANSIENT - QUADRATURE AXIS T'' _q		0.0100			
EXCITER TIME CONSTANT T _e		0.0200			
ARMATURE SHORT CIRCUIT T _a		0.0150			
Short Circuit Ratio: 0.55		Stator Resistance = 0.0097Ohms		Field Resistance = 0.5566 Ohms	

Voltage Regulation		Generator Excitation		
Voltage level adjustment: +/-	5.0%	No Load	Full Load, (rated) pf	
Voltage regulation, steady state: +/-	0.8%		Series	Parallel
Voltage regulation with 3% speed change: +/-	0.8%	Excitation voltage:	11.4 Volts	34.4 Volts
Waveform deviation line - line, no load: less than	2.0%	Excitation current	1.1 Amps	2.7 Amps
Telephone influence factor: less than	50			

[Top...](#)

Selected Model

Engine: C13 **Generator Frame:** M3134L41 **Genset Rating (kW):** 400.0 **Line Voltage:** 480
Fuel: Diesel **Generator Arrangement:** 6263795 **Genset Rating (kVA):** 500.0 **Phase Voltage:** 277
Frequency: 60 **Excitation Type:** Self Excited **Pwr. Factor:** 0.8 **Rated Current:** 601.4
Duty: STANDBY **Connection:** - STAR **Application:** EPG **Status:** Current
Version: 42423 /44804 /43655 /11990

Generator Mechanical Information

Center of Gravity		
Dimension X	-484 mm	-19.1 IN.
Dimension Y	0 mm	0.0 IN.
Dimension Z	0 mm	0.0 IN.

- "X" is measured from driven end of generator and parallel to rotor. Towards engine fan is positive. See General Information for details
- "Y" is measured vertically from rotor center line. Up is positive.
- "Z" is measured to left and right of rotor center line. To the right is positive.

Generator WT = 1142 kg	* Rotor WT = 457 kg	* Stator WT = 685 kg
2,518 LB	1,008 LB	1,510 LB

Rotor Balance = 0 mm deflection PTP
 Overspeed Capacity = 125% of synchronous speed

Generator Torsional Data

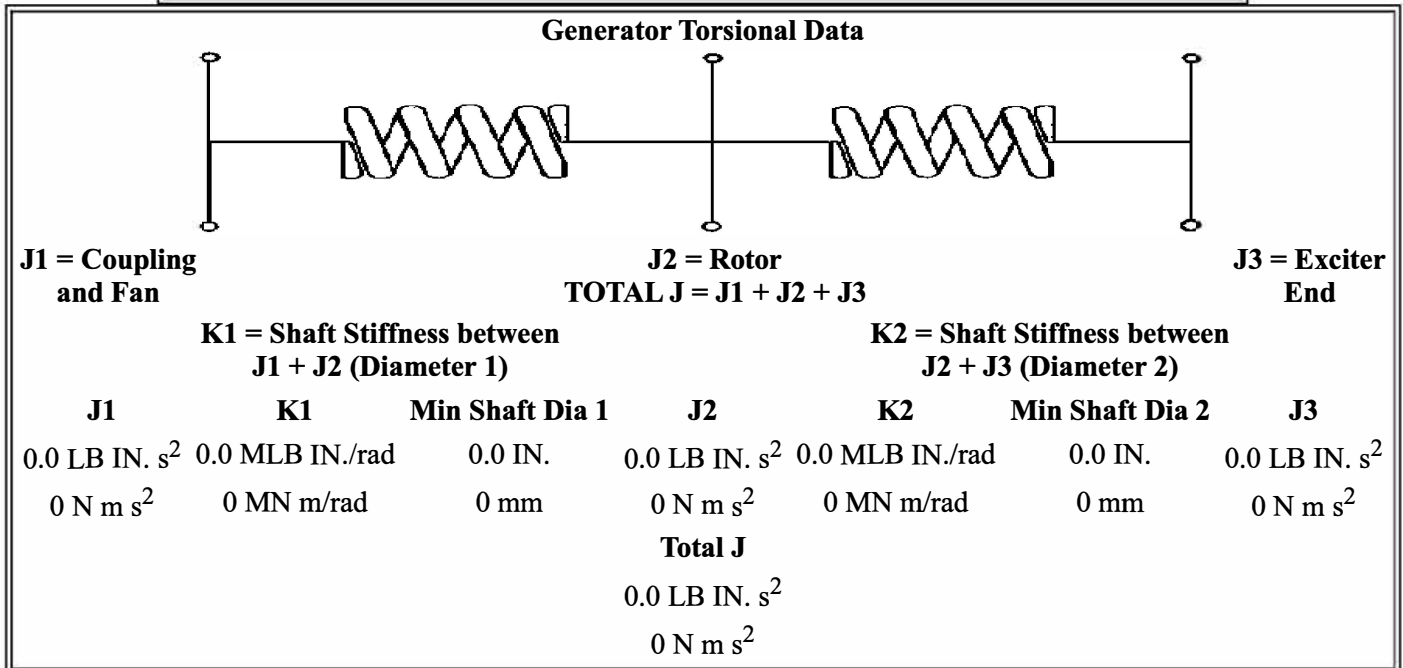

[Top...](#)

Selected Model

Engine: C13 **Generator Frame:** M3134L41 **Genset Rating (kW):** 400.0 **Line Voltage:** 480
Fuel: Diesel **Generator Arrangement:** 6263795 **Genset Rating (kVA):** 500.0 **Phase Voltage:** 277
Frequency: 60 **Excitation Type:** Self Excited **Pwr. Factor:** 0.8 **Rated Current:** 601.4
Duty: STANDBY **Connection:** - STAR **Application:** EPG **Status:** Current
Version: 42423 /44804 /43655 /11990

Generator Cooling Requirements - Temperature - Insulation Data	
Cooling Requirements:	Temperature Data: (Ambient 40 °C)
Heat Dissipated: 21.9 kW	Stator Rise: 105 °C
Air Flow: 66 m ³ /min	Rotor Rise: 105 °C
Insulation Class: H	
Insulation Reg. as shipped: 100MΩ minimum at 40 °C	

Thermal Limits of Generator	
Frequency:	60 Hz
Line to Line Voltage:	480 Volts
B BR 80/40	500 kVA
F BR -105/40	568.8 kVA
H BR - 125/40	625 kVA
F PR - 130/40	625 kVA
H PR - 150/40	662.5 kVA
H PR27 - 163/27	687.5 kVA

[Top...](#)

Selected Model

Engine: C13 **Generator Frame:** M3134L41 **Genset Rating (kW):** 400.0 **Line Voltage:** 480
Fuel: Diesel **Generator Arrangement:** 6263795 **Genset Rating (kVA):** 500.0 **Phase Voltage:** 277
Frequency: 60 **Excitation Type:** Self Excited **Pwr. Factor:** 0.8 **Rated Current:** 601.4
Duty: STANDBY **Connection:** - STAR **Application:** EPG **Status:** Current
Version: 42423 /44804 /43655 /11990

Starting Capability & Current Decrement
Motor Starting Capability (0.6 pf)

SKVA Percent Volt Dip	
63	2.5
128	5.0
198	7.5
271	10.0
348	12.5
430	15.0
517	17.5
610	20.0
708	22.5
813	25.0
925	27.5
1,045	30.0
1,174	32.5
1,313	35.0
1,463	37.5
1,626	40.0

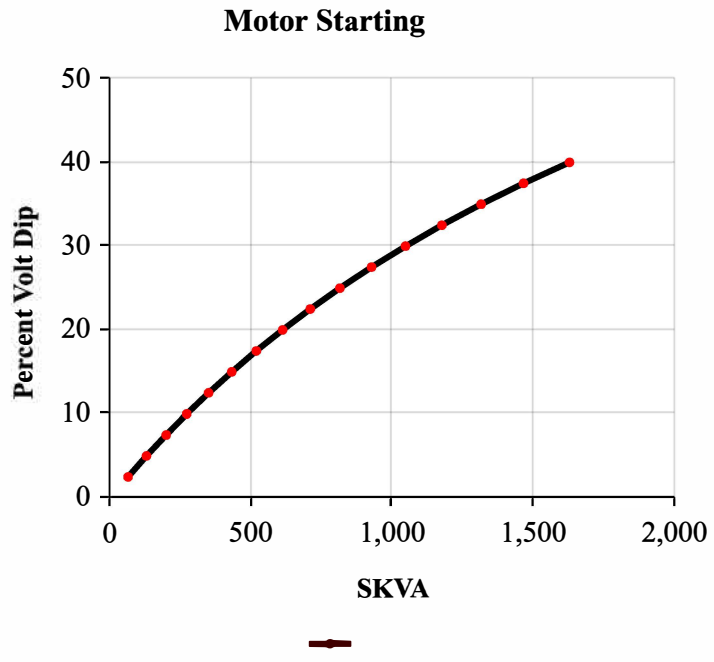

Current Decrement Data

E Time Cycle AMP	
0.0	6,118
1.0	4,037
2.0	3,217
3.0	2,698
4.0	2,287
5.0	1,941
7.5	1,279
10.0	832
12.5	529
15.0	352
20.0	199
25.0	146
30.0	125
35.0	117
40.0	113
45.0	111

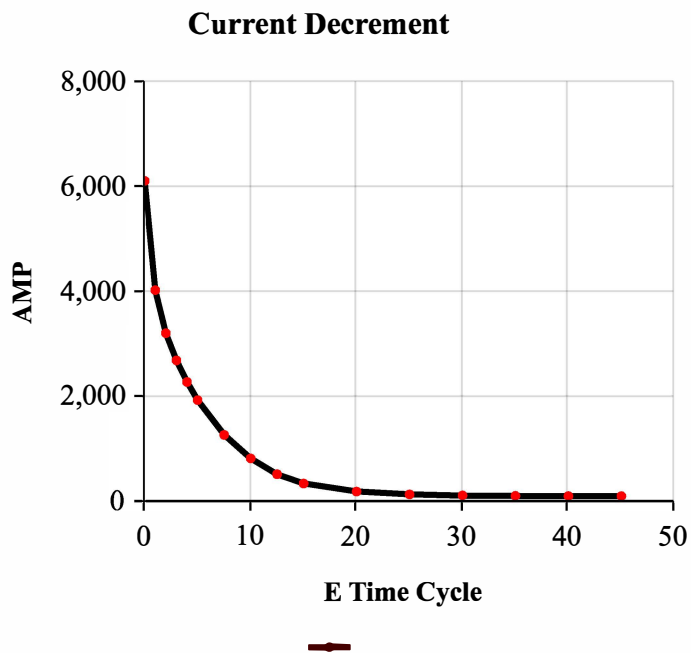

Instantaneous 3 Phase Fault Current: 6118 Amps Instantaneous Line - Line Fault Current: 4954 Amps
Instantaneous Line - Neutral Fault Current: 8352 Amps

[Top...](#)

Selected Model

Engine: C13	Generator Frame: M3134L41	Genset Rating (kW): 400.0	Line Voltage: 480
Fuel: Diesel	Generator Arrangement: 6263795	Genset Rating (kVA): 500.0	Phase Voltage: 277
Frequency: 60	Excitation Type: Self Excited	Pwr. Factor: 0.8	Rated Current: 601.4
Duty: STANDBY	Connection: - STAR	Application: EPG	Status: Current
Version: 42423 /44804 /43655 /11990			

Generator Output Characteristic Curves
Open Circuit Curve

Open Circuit

Field Current	Line - Line Volt
0.0	0
11.1	288
13.4	336
16.0	384
19.8	432
26.0	480
37.6	528
61.2	576
111.2	624
220.1	672

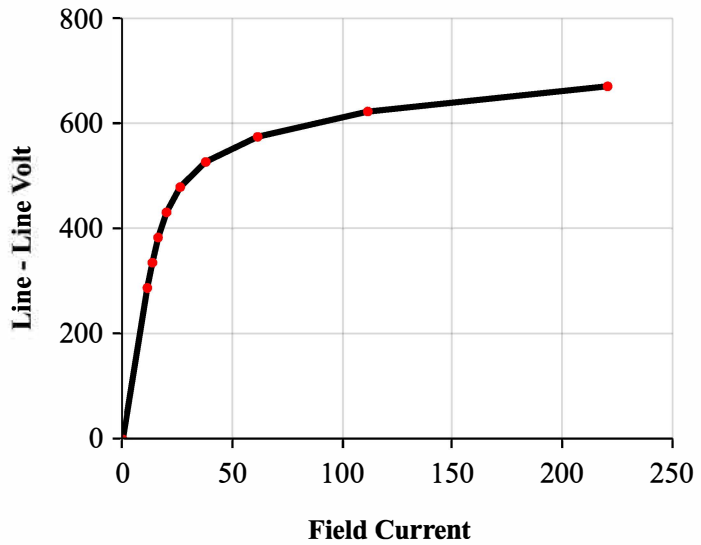

Short Circuit Curve

Short Circuit

Field Current	Armature Current
0.0	0
29.9	361
34.9	421
39.9	481
44.9	541
49.9	601
54.9	662
59.9	722
64.9	782
69.9	842

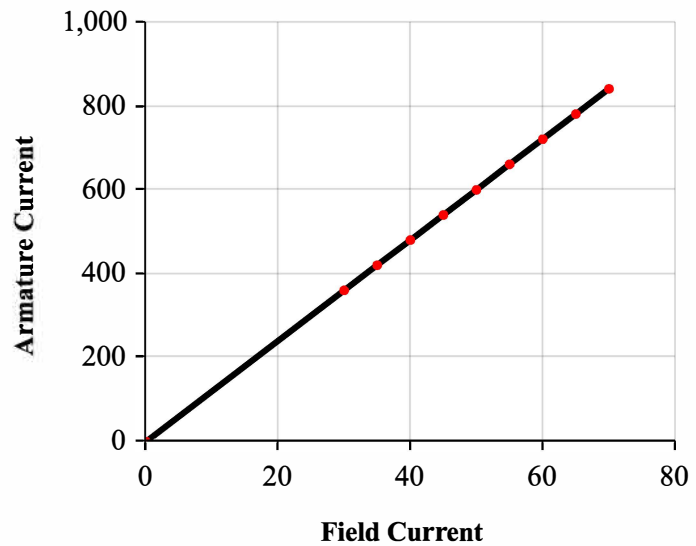

[Top...](#)

Selected Model

Engine: C13 **Generator Frame:** M3134L41 **Genset Rating (kW):** 400.0 **Line Voltage:** 480
Fuel: Diesel **Generator Arrangement:** 6263795 **Genset Rating (kVA):** 500.0 **Phase Voltage:** 277
Frequency: 60 **Excitation Type:** Self Excited **Pwr. Factor:** 0.8 **Rated Current:** 601.4
Duty: STANDBY **Connection:** - STAR **Application:** EPG **Status:** Current
Version: 42423 /44804 /43655 /11990

Zero Power Factor Curve

Zero Power

Field Current	Line - Line Volt
49.9	0
65.7	240
69.8	288
76.7	336
89.7	384
116.5	432
173.8	480
299.0	528
574.8	576
1,184.9	624

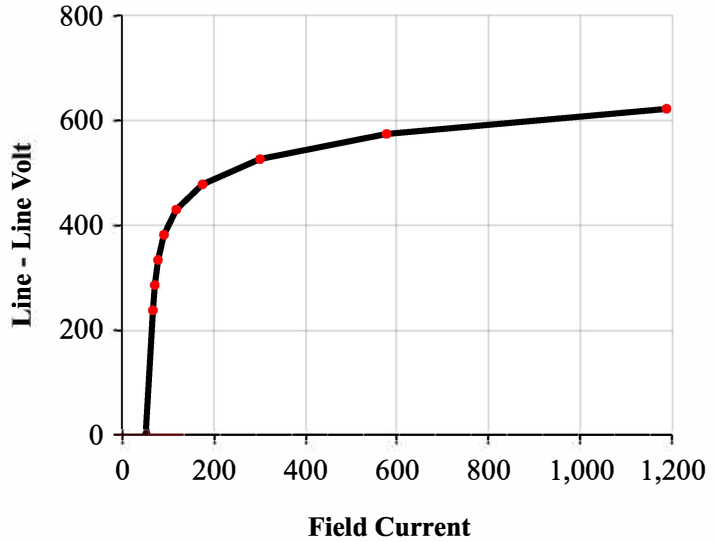

Air Gap Curve

Air Gap

Field Current	Line - Line Volt
0.0	0
10.8	288
12.6	336
14.4	384
16.2	432
18.0	480
19.8	528
21.6	576
23.4	624
25.2	672

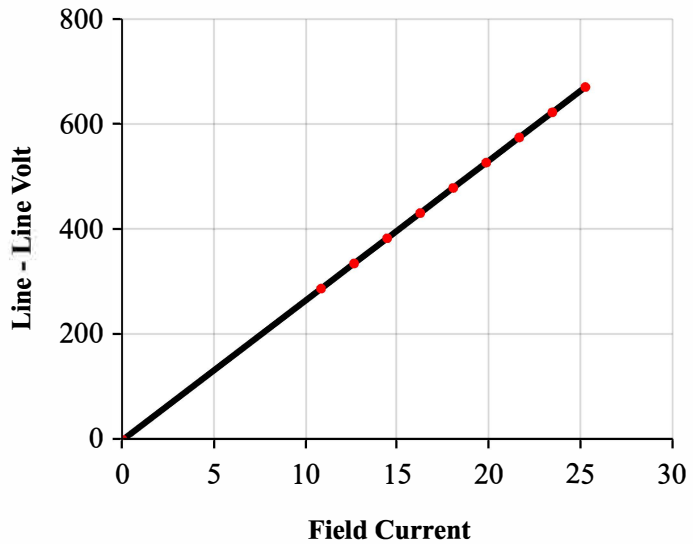

[Top...](#)

Selected Model

Engine: C13	Generator Frame: M3134L41	Genset Rating (kW): 400.0	Line Voltage: 480
Fuel: Diesel	Generator Arrangement: 6263795	Genset Rating (kVA): 500.0	Phase Voltage: 277
Frequency: 60	Excitation Type: Self Excited	Pwr. Factor: 0.8	Rated Current: 601.4
Duty: STANDBY	Connection: - STAR	Application: EPG	Status: Current

Version: 42423 /44804 /43655 /11990

Reactive Capability Curve

Operating Chart

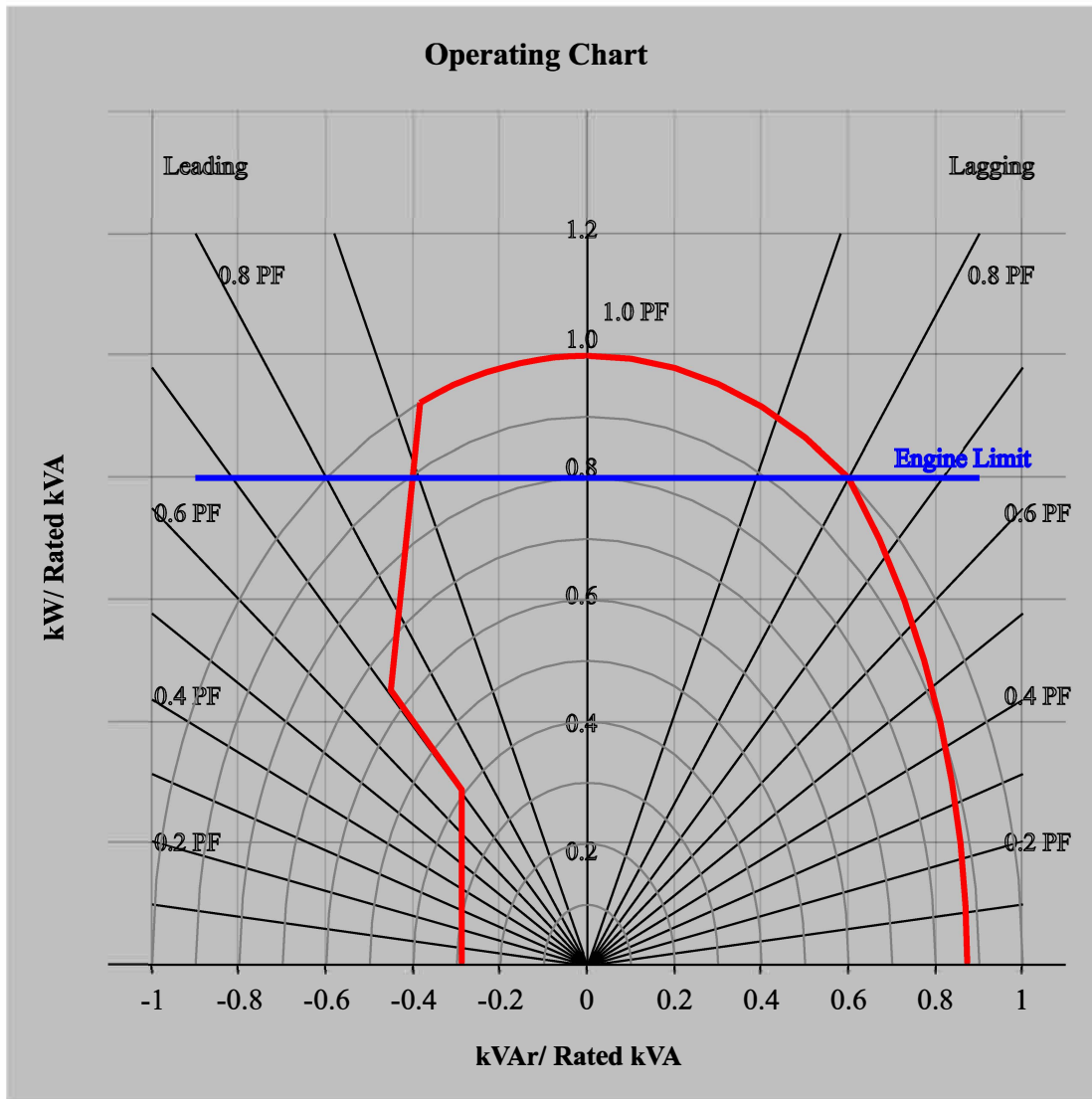

[Top...](#)

Selected Model

Engine: C13	Generator Frame: M3134L41	Genset Rating (kW): 400.0	Line Voltage: 480
Fuel: Diesel	Generator Arrangement: 6263795	Genset Rating (kVA): 500.0	Phase Voltage: 277
Frequency: 60	Excitation Type: Self Excited	Pwr. Factor: 0.8	Rated Current: 601.4
Duty: STANDBY	Connection: - STAR	Application: EPG	Status: Current
Version: 42423 /44804 /43655 /11990			

General Information

GENERATOR INFORMATION (DM7900)

1. Motor Starting

Motor starting curves are obtained in accordance with IEC60034, and are displayed at 0.6 power factor.

2. Voltage Dip

Prediction of the generator synchronous voltage dip can be made by consulting the plot for the voltage dip value that corresponds to the desired motor starting kVA value.

3. Definitions

A) Generator Keys

Frame: abbreviation of generator frame size

Freq: frequency in hertz.

PP/SB: prime/standby duty respectively

Volts: line - line terminal voltage

kW: rating in electrical kilo watts

Model: engine sales model

B) Generator Temperature Rise

The indicated temperature rises are the IEC/NEMA limits for standby or prime power applications. The quoted rise figures are maximum limits only and are not necessarily indicative of the actual temperature rise of a given machine winding.

C) Centre of Gravity

The specified centre of gravity is for the generator only. For single bearing, and two bearing close coupled generators, the center of gravity is measured from the generator/engine flywheel-housing interface and from the centreline of the rotor Shaft.

For two bearing, standalone generators, the center of gravity is measured from the end of the rotor shaft and from the centerline of the rotor shaft.

D) Generator Current Decrement Curves

The generator current decrement curve indicates the generator armature current arising from a symmetrical three-phase fault at the generator terminals. Generators equipped with AREP or PMG excitation systems will sustain 300% of rated armature current for 10 seconds.

E) Generator Efficiency Curves

The efficiency curve is displayed for the generator only under the given conditions of rating, voltage, frequency and power factor. This is not the overall generating set efficiency curve.

Caterpillar Confidential: **Green**

Content Owner: Commercial Processes Division

Web Master(s): [PSG Web Based Systems Support](#)

Current Date: 5/12/2026, 10:45:56 AM

© Caterpillar Inc. 2026 All Rights Reserved.

[Privacy.](#)

[Cookie Settings](#)

GENSET POWER WITH FAN	PERCENT LOAD	ENGINE POWER	INLET MFLD PRES	INLET MFLD TEMP	EXH MFLD TEMP	EXH MFLD PRES	ENGINE OUTLET TEMP	COMPRESSOR OUTLET PRES	COMPRESSOR OUTLET TEMP
80.0	20	149	8.5	85.3	886.6	8.2	770.9	10	143.6
40.0	10	90.8	3.6	82.6	689.5	5.6	609.6	5	114.6

GENSET POWER WITH FAN	PERCENT LOAD	ENGINE POWER	WET INLET AIR VOL FLOW RATE	WET EXH GAS VOL FLOW RATE	ENGINE OUTLET GAS MASS FLOW RATE	WET INLET AIR MASS FLOW RATE	WET EXH GAS MASS FLOW RATE	WET EXH VOL FLOW RATE (32 DEG F AND 29.98 IN HG)	DRY EXH VOL FLOW RATE (32 DEG F AND 29.98 IN HG)
EKW	%	BHP	CFM	CFM	LB/HR	LB/HR	FT3/MIN	FT3/MIN	FT3/MIN
400.0	100	609	978.1	2,936.2	4,292.2	4,490.4	950.7	854.7	
360.0	90	546	915.9	2,656.6	3,998.8	4,176.7	879.0	792.5	
320.0	80	486	970.5	2,788.5	4,248.8	4,421.0	930.2	846.5	
300.0	75	457	982.7	2,801.1	4,301.0	4,468.6	939.1	857.4	
280.0	70	428	963.1	2,705.2	4,203.1	4,362.5	914.6	836.0	
240.0	60	372	901.9	2,463.5	3,915.9	4,057.6	850.3	779.2	
200.0	50	316	812.5	2,156.6	3,510.3	3,632.6	764.3	702.0	
160.0	40	261	687.0	1,781.4	2,955.8	3,057.3	649.3	597.7	
120.0	30	206	559.5	1,398.1	2,396.3	2,476.6	528.9	488.0	
100.0	25	178	501.9	1,216.0	2,144.3	2,213.9	470.7	434.8	
80.0	20	149	454.1	1,050.9	1,934.8	1,994.0	419.9	388.7	
40.0	10	90.8	397.9	789.9	1,686.8	1,725.7	363.2	341.4	

Heat Rejection Data [Top](#)

GENSET POWER WITH FAN	PERCENT LOAD	ENGINE POWER	REJECTION TO JACKET WATER	REJECTION TO ATMOSPHERE	REJECTION TO EXH	EXHAUST RECOVERY TO 350F	FROM OIL COOLER	FROM AFTERCOOLER	WORK REENERGY	LOW HEAT VALUE ENERGY	HIGH HEAT VALUE ENERGY
EKW	%	BHP	BTU/MIN	BTU/MIN	BTU/MIN	BTU/MIN	BTU/MIN	BTU/MIN	BTU/MIN	BTU/MIN	BTU/MIN
400.0	100	609	8,952	2,925	23,022	13,776	3,243	4,130	25,831	60,887	64,860
360.0	90	546	8,186	2,654	20,622	12,177	2,905	3,479	23,152	54,534	58,093
320.0	80	486	7,906	2,618	21,212	12,600	2,812	3,904	20,601	52,796	56,241
300.0	75	457	7,710	2,546	21,145	12,570	2,738	3,995	19,365	51,406	54,761
280.0	70	428	7,378	2,442	20,304	12,022	2,604	3,800	18,150	48,885	52,075
240.0	60	372	6,706	2,418	18,182	10,623	2,315	3,233	15,765	43,469	46,305
200.0	50	316	6,033	2,483	15,558	8,900	1,999	2,492	13,418	37,535	39,984
160.0	40	261	5,465	2,508	12,515	6,965	1,660	1,628	11,079	31,161	33,194
120.0	30	206	4,843	2,208	9,534	5,102	1,312	920	8,725	24,624	26,230
100.0	25	178	4,472	1,897	8,187	4,276	1,137	653	7,535	21,350	22,743
80.0	20	149	4,040	1,542	6,945	3,504	965	452	6,327	18,124	19,307
40.0	10	90.8	2,963	1,112	4,536	1,834	634	216	3,852	11,904	12,681

Emissions Data [Top](#)

Units Filter ▼

DIESEL

RATED SPEED NOMINAL DATA: 1800 RPM

GENSET POWER WITH FAN	EKW	400.0	300.0	200.0	100.0	40.0
ENGINE POWER	BHP	609	457	316	178	90.8
PERCENT LOAD	%	100	75	50	25	10
TOTAL NOX (AS NO2)	G/HR	2,757	989	544	534	343
TOTAL CO	G/HR	741	456	592	620	414
TOTAL HC	G/HR	6	18	30	30	43
TOTAL CO2	KG/HR	275	236	172	98	55
PART MATTER	G/HR	31.4	33.7	19.4	16.5	22.7
TOTAL NOX (AS NO2)	(CORR 5% O2) MG/NM3	2,297.5	963.2	721.7	1,293.0	1,373.1
TOTAL CO	(CORR 5% O2) MG/NM3	615.3	450.6	793.8	1,542.8	1,663.2
TOTAL HC	(CORR 5% O2) MG/NM3	4.0	15.1	34.9	67.5	179.3
PART MATTER	(CORR 5% O2) MG/NM3	21.1	27.1	21.7	34.3	97.2
TOTAL NOX (AS NO2)	(CORR 15% O2) MG/NM3	852.5	357.4	267.8	479.8	509.5
TOTAL CO	(CORR 15% O2) MG/NM3	228.3	167.2	294.5	572.5	617.1
TOTAL HC	(CORR 15% O2) MG/NM3	1.5	5.6	13.0	25.1	66.5
PART MATTER	(CORR 15% O2) MG/NM3	7.8	10.1	8.0	12.7	36.1
TOTAL NOX (AS NO2)	(CORR 5% O2) PPM	1,119	469	352	630	669
TOTAL CO	(CORR 5% O2) PPM	492	361	635	1,234	1,331
TOTAL HC	(CORR 5% O2) PPM	7	28	65	126	335
TOTAL NOX (AS NO2)	(CORR 15% O2) PPM	415	174	130	234	248

GENSET POWER WITH FAN		EKW	400.0	300.0	200.0	100.0	40.0
ENGINE POWER		BHP	609	457	316	178	90.8
PERCENT LOAD		%	100	75	50	25	10
TOTAL CO	(CORR 15% O2)	PPM	183	134	236	458	494
TOTAL HC	(CORR 15% O2)	PPM	3	10	24	47	124
TOTAL NOX (AS NO2)		G/HP-HR	4.61	2.19	1.73	3.02	3.80
TOTAL CO		G/HP-HR	1.24	1.01	1.88	3.50	4.57
TOTAL HC		G/HP-HR	0.01	0.04	0.10	0.17	0.48
PART MATTER		G/HP-HR	0.05	0.07	0.06	0.09	0.25
TOTAL NOX (AS NO2)		G/KW-HR	6.18	2.93	2.32	4.05	5.09
TOTAL CO		G/KW-HR	1.66	1.35	2.53	4.70	6.13
TOTAL HC		G/KW-HR	0.01	0.05	0.13	0.23	0.64
PART MATTER		G/KW-HR	0.07	0.10	0.08	0.12	0.34
TOTAL NOX (AS NO2)		LB/HR	6.08	2.18	1.20	1.18	0.76
TOTAL CO		LB/HR	1.63	1.00	1.31	1.37	0.91
TOTAL HC		LB/HR	0.01	0.04	0.07	0.07	0.10
TOTAL CO2		LB/HR	605	520	378	215	121
PART MATTER		LB/HR	0.07	0.07	0.04	0.04	0.05
OXYGEN IN EXH		%	7.4	9.6	10.8	11.8	14.4
DRY SMOKE OPACITY		%	1.7	1.1	1.1	3.0	2.0
BOSCH SMOKE NUMBER			1.06	0.90	0.88	1.38	1.13

RATED SPEED POTENTIAL SITE VARIATION: 1800 RPM

GENSET POWER WITH FAN		EKW	400.0	300.0	200.0	100.0	40.0
ENGINE POWER		BHP	609	457	316	178	90.8
PERCENT LOAD		%	100	75	50	25	10
TOTAL NOX (AS NO2)		G/HR	2,977	1,068	588	577	371
TOTAL CO		G/HR	1,386	852	1,107	1,159	773
TOTAL HC		G/HR	11	34	57	58	82
PART MATTER		G/HR	61.3	65.7	37.7	32.1	44.3
TOTAL NOX (AS NO2)	(CORR 5% O2)	MG/NM3	2,481.2	1,040.3	779.4	1,396.4	1,483.0
TOTAL CO	(CORR 5% O2)	MG/NM3	1,150.6	842.7	1,484.4	2,885.1	3,110.1
TOTAL HC	(CORR 5% O2)	MG/NM3	7.5	28.5	66.0	127.6	338.9
PART MATTER	(CORR 5% O2)	MG/NM3	41.1	52.9	42.2	66.9	189.6
TOTAL NOX (AS NO2)	(CORR 15% O2)	MG/NM3	920.7	386.0	289.2	518.2	550.3
TOTAL CO	(CORR 15% O2)	MG/NM3	427.0	312.7	550.8	1,070.6	1,154.1
TOTAL HC	(CORR 15% O2)	MG/NM3	2.8	10.6	24.5	47.4	125.7
PART MATTER	(CORR 15% O2)	MG/NM3	15.2	19.6	15.7	24.8	70.3
TOTAL NOX (AS NO2)	(CORR 5% O2)	PPM	1,209	507	380	680	722
TOTAL CO	(CORR 5% O2)	PPM	920	674	1,188	2,308	2,488
TOTAL HC	(CORR 5% O2)	PPM	14	53	123	238	633
TOTAL NOX (AS NO2)	(CORR 15% O2)	PPM	448	188	141	252	268
TOTAL CO	(CORR 15% O2)	PPM	342	250	441	856	923
TOTAL HC	(CORR 15% O2)	PPM	5	20	46	88	235
TOTAL NOX (AS NO2)		G/HP-HR	4.98	2.36	1.87	3.26	4.10
TOTAL CO		G/HP-HR	2.32	1.88	3.52	6.55	8.55
TOTAL HC		G/HP-HR	0.02	0.08	0.18	0.33	0.90
PART MATTER		G/HP-HR	0.10	0.15	0.12	0.18	0.49
TOTAL NOX (AS NO2)		G/KW-HR	6.68	3.17	2.51	4.37	5.50
TOTAL CO		G/KW-HR	3.11	2.53	4.72	8.79	11.46
TOTAL HC		G/KW-HR	0.02	0.10	0.24	0.44	1.21
PART MATTER		G/KW-HR	0.14	0.19	0.16	0.24	0.66
TOTAL NOX (AS NO2)		LB/HR	6.56	2.36	1.30	1.27	0.82
TOTAL CO		LB/HR	3.05	1.88	2.44	2.55	1.71
TOTAL HC		LB/HR	0.02	0.07	0.13	0.13	0.18
PART MATTER		LB/HR	0.14	0.14	0.08	0.07	0.10

Regulatory Information [Top](#)

EPA EMERGENCY STATIONARY

2011 - ----

CYCLE : D2

GASEOUS EMISSIONS DATA MEASUREMENTS PROVIDED TO THE EPA ARE CONSISTENT WITH THOSE DESCRIBED IN EPA 40 CFR PART 60 SUBPART IIII AND ISO 8178 FOR MEASURING HC, CO, PM, AND NOX. THE "MAX LIMITS" SHOWN BELOW ARE WEIGHTED CYCLE AVERAGES AND ARE IN COMPLIANCE WITH THE EMERGENCY STATIONARY REGULATIONS.

Locality	Agency	Regulation	Tier/Stage	Max Limits - G/BKW - HR
U.S. (INCL CALIF)	EPA	STATIONARY	EMERGENCY STATIONARY	CO: 3.5 NO _x + HC: 4.0 PM: 0.20

Altitude Derate Data [Top](#)

STANDARD

ALTITUDE CORRECTED POWER CAPABILITY (BHP)

AMBIENT OPERATING TEMP (F)	30	40	50	60	70	80	90	100	110	120	130	140	NORMAL
ALTITUDE (FT)													
0	609	609	609	609	609	609	609	609	609	600	590	580	609
1,000	609	609	609	609	609	609	609	598	588	578	568	558	609
2,000	609	609	609	609	609	597	587	576	566	556	547	538	607
3,000	609	609	609	597	586	575	564	554	545	535	526	517	588
4,000	609	597	586	574	564	553	543	533	524	515	506	498	570
5,000	586	575	563	552	542	532	522	513	504	495	487	479	552
6,000	564	552	542	531	521	511	502	493	484	476	468	460	534
7,000	542	531	520	510	501	492	483	474	466	458	450	442	517
8,000	520	510	500	490	481	472	464	455	447	440	432	425	500
9,000	500	490	480	471	462	454	445	437	430	422	415	408	484
10,000	480	470	461	452	444	435	427	420	412	405	398	392	467
11,000	460	451	442	434	426	418	410	403	396	389	382	376	452
12,000	442	433	424	416	408	401	393	386	380	373	367	361	437
13,000	424	415	407	399	392	384	377	371	364	358	352	346	422
14,000	406	398	390	382	375	368	362	355	349	343	337	331	407
15,000	389	381	374	366	359	353	346	340	334	328	323	318	393

Cross Reference [Top](#)

Test Spec	Setting	Engine Arrangement	Engineering Model	Engineering Model Version	Start Effective Serial Number	End Effective Serial Number
0K9333	PP7710	4343726	PG045	LS	PW300001	

Performance Parameter Reference [Top](#)

Parameters Reference: DM9600 - 15 PERFORMANCE DEFINITIONS

PERFORMANCE DEFINITIONS DM9600

APPLICATION: Engine performance tolerance values below are representative of a typical production engine tested in a calibrated dynamometer test cell at SAE J1995 standard reference conditions. Caterpillar maintains ISO9001:2000 certified quality management systems for engine test Facilities to assure accurate calibration of test equipment. Engine test data is corrected in accordance with SAE J1995. Additional reference material SAE J1228, J1349, ISO 8665, 3046-1:2002E, 3046-3:1989, 1585, 2534, 2288, and 9249 may apply in part or are similar to SAE J1995. Special engine rating request (SERR) test data shall be noted.

PERFORMANCE PARAMETER TOLERANCE FACTORS: Power +/- 3% Torque +/- 3% Exhaust stack temperature +/- 8% Inlet airflow +/- 5% Intake manifold pressure-gage +/- 10% Exhaust flow +/- 6% Specific fuel consumption +/- 3% Specific fuel consumption (C7-C18) +/- 4% Fuel rate +/- 5% Specific DEF consumption +/- 3% DEF rate +/- 5% Heat rejection +/- 5% Heat rejection exhaust only +/- 10% Heat rejection CEM only +/- 10% Heat Rejection values based on using treated water.

Torque is included for truck and industrial applications, do not use for Gen Set or steady state applications.

On C7 - C18 engines, at speeds of 1100 RPM and under these values are provided for reference only, and may not meet the tolerance listed.

On 3500 and C175 engines, at speeds below Peak Torque these values are provided for reference only, and may not meet the tolerance listed.

These values do not apply to C280/3600. For these models, see the tolerances listed below.

C280/3600 HEAT REJECTION TOLERANCE FACTORS: Heat rejection +/- 10% Heat rejection to Atmosphere +/- 50% Heat rejection to Lube Oil +/- 20% Heat rejection to Aftercooler +/- 5%

TEST CELL TRANSDUCER TOLERANCE FACTORS: Torque +/- 0.5% Speed +/- 0.2% Fuel flow +/- 1.0% Temperature +/- 2.0 C degrees Intake manifold pressure +/- 0.1 kPa

**Parameters Reference: DM9600 - 15
PERFORMANCE DEFINITIONS**

OBSERVED ENGINE PERFORMANCE IS CORRECTED TO SAE J1995 REFERENCE AIR AND FUEL CONDITIONS.

REFERENCE ATMOSPHERIC INLET AIR FOR 3500 ENGINES AND SMALLER SAE J1228 AUG2002 for marine engines, and J1995 JAN2014 for other engines, reference atmospheric pressure is 100 KPA (29.61 in hg), and standard temperature is 25deg C (77 deg F) at 30% relative humidity at the stated aftercooler water temp, or inlet manifold temp.

FOR 3600 ENGINES, Engine rating obtained and presented in accordance with ISO 3046/1 and SAE J1995 JANJAN2014 reference atmospheric pressure is 100 KPA (29.61 in hg), and standard temperature is 25deg C (77 deg F) at 30% relative humidity and 150M altitude at the stated aftercooler water temperature.

MEASUREMENT LOCATION FOR INLET AIR TEMPERATURE Location for air temperature measurement air cleaner inlet at stabilized operating conditions.

REFERENCE EXHAUST STACK DIAMETER The Reference Exhaust Stack Diameter published with this dataset is only used for the calculation of Smoke Opacity values displayed in this dataset. This value does not necessarily represent the actual stack diameter of the engine due to the variety of exhaust stack adapter options available. Consult the price list, engine order or general dimension drawings for the actual stack diameter size ordered or options available.

REFERENCE FUEL DIESEL Reference fuel is #2 distillate diesel with a 35API gravity; A lower heating value is 42,780 KJ/KG (18,390 BTU/LB) when used at 15 deg C (59 deg F), where the density is 850 G/Liter (7.0936 Lbs/Gal).

GAS Reference natural gas fuel has a lower heating value of 33.74 KJ/L (905 BTU/CU Ft). Low BTU ratings are based on 18.64 KJ/L (500 BTU/CU FT) lower heating value gas. Propane ratings are based on 87.56 KJ/L (2350 BTU/CU Ft) lower heating value gas.

ENGINE POWER (NET) IS THE CORRECTED FLYWHEEL POWER (GROSS) LESS EXTERNAL AUXILIARY LOAD Engine corrected gross output includes the power required to drive standard equipment; lube oil, scavenge lube oil, fuel transfer, common rail fuel, separate circuit aftercooler and jacket water pumps. Engine net power available for the external (flywheel) load is calculated by subtracting the sum of auxiliary load from the corrected gross flywheel out put power. Typical auxiliary loads are radiator cooling fans, hydraulic pumps, air compressors and battery charging alternators. For Tier 4 ratings additional Parasitic losses would also include Intake, and Exhaust Restrictions.

ALTITUDE CAPABILITY Altitude capability is the maximum altitude above sea level at standard temperature and standard pressure at which the engine could develop full rated output power on the current performance data set.

Standard temperature values versus altitude could be seen on TM2001.

When viewing the altitude capability chart the ambient temperature is the inlet air temp at the compressor inlet. Engines with ADEM MEUI and HEUI fuel systems operating at conditions above the defined altitude capability derate for atmospheric pressure and temperature conditions outside the values defined, see TM2001.

Mechanical governor controlled unit injector engines require a setting change for operation at conditions above the altitude defined on the engine performance sheet. See your Caterpillar technical representative for non standard ratings.

REGULATIONS AND PRODUCT COMPLIANCE TMI Emissions information is presented at 'nominal' and 'Potential Site Variation' values for standard ratings. No tolerances are applied to the emissions data. These values are subject to change at any time. The controlling federal and local emission requirements need to be verified by your Caterpillar technical representative.

Customer's may have special emission site requirements that need to be verified by the Caterpillar Product Group engineer.

EMISSION CYCLE LIMITS: Cycle emissions Max Limits apply to cycle-weighted averages only. Emissions at individual load points may exceed the cycle-weighted limit.

WET & DRY EXHAUST/EMISSIONS DESCRIPTION: Wet - Total exhaust flow or concentration of total exhaust flow
Dry - Total exhaust flow minus water vapor or concentration of exhaust flow with water vapor excluded

EMISSIONS DEFINITIONS: Emissions : DM1176

EMISSION CYCLE DEFINITIONS

1. For constant-speed marine engines for ship main propulsion, including,diesel-electric drive, test cycle E2 shall be applied, for controllable-pitch propeller sets test cycle E2 shall be applied.
2. For propeller-law-operated main and propeller-law-operated auxiliary engines the test cycle E3 shall be applied.
3. For constant-speed auxiliary engines test cycle D2 shall be applied.
4. For variable-speed, variable-load auxiliary engines, not included above, test cycle C1 shall be applied.

HEAT REJECTION DEFINITIONS: Diesel Circuit Type and HHV Balance : DM9500

HIGH DISPLACEMENT (HD) DEFINITIONS: 3500: EM1500

**Parameters Reference: DM9600 - 15
PERFORMANCE DEFINITIONS**

RATING DEFINITIONS: Agriculture : TM6008

Fire Pump : TM6009

Generator Set : TM6035

Generator (Gas) : TM6041

Industrial Diesel : TM6010

Industrial (Gas) : TM6040

Irrigation : TM5749

Locomotive : TM6037

Marine Auxiliary : TM6036

Marine Prop (Except 3600) : TM5747

Marine Prop (3600 only) : TM5748

MSHA : TM6042

Oil Field (Petroleum) : TM6011

Off-Highway Truck : TM6039

On-Highway Truck : TM6038

SOUND DEFINITIONS: Sound Power : DM8702

Sound Pressure : TM7080

Date Released : 03/12/24

Caterpillar Confidential: **Green**

Content Owner: Commercial Processes Division

Web Master(s): [PSG Web Based Systems Support](#)

Current Date: 5/12/2026, 10:41:52 AM

© Caterpillar Inc. 2026 All Rights Reserved.

[Privacy](#).

[Cookie Settings](#)



Image shown may not reflect actual configuration.

D250 GC – D600 GC Sound Attenuated Enclosures

60 Hz

Features

Robust Construction

- Manufactured from carbon steel
- Safeguards genset against environmental and weather conditions
- Factory installed on skid base or tanks base
- Environmentally friendly, polyester powder baked paint
- Enclosure constructed with 18-gauge steel
- Interior zinc plated fasteners
- Internally mounted exhaust silencing system
- Comply with ASCE /SEI 7 for Wind loads up to 100 mph
- Designed and tested to comply with UL 2200 Listed generator set package

Excellent Access

- Large cable entry area for installation ease
- Accommodates side mounted single or multiple breakers
- Two doors on both sides
- Vertically hinged allow 180° opening rotation
- Radiator fill cover

Security and Safety

- Lockable access doors which give full access to control panel and breaker
- Cooling fan and battery charging alternator fully guarded
- Fuel fill, oil fill and battery can only be reached via lockable access
- Externally mounted emergency stop button (Optional)
- Designed for spreader bar lifting to ensure safety
- Stub-up area is rodent proof

Sound Attenuated Level 2

- Caterpillar white paint
- UL Listed integral fuel tank with 24 hours running time capacity (Optional)
- DC lighting package (Optional)

Enclosure Package Operating Characteristics

Enclosure Type	Standby	Cooling Air Flow Rate		Ambient Capability*		Sound Pressure Levels (dBA) at 7m (23 ft)
	ekW	m ³ /s	cfm	°C	°F	100% Load
Level 2 Sound Attenuated Enclosure (Steel)	250	6.4	13561	57	135	74
	300	6.4	13561	51	125	74
	350	7.4	15680	57	134	71
	400	7.4	15680	53	127	71
	450	8.4	17692	54	130	73
	500	8.4	17692	50	122	73
	550	11.2	23731	56	133	73
	600	11.2	23731	53	127	73

*Cooling system performance at sea level. Consult your Cat[®] dealer for site specific ambient and altitude capabilities.

Note: Sound level measurements are subject to instrumentation, installation and manufacturing variability, as well as ambient site conditions

Weights and Dimensions

Enclosure Type	Standby Ratings	Length, L		Width, W		Height, H		Package Weights	
	ekW	mm	in	mm	in	mm	in	kg	lb
Sound Attenuated Enclosure on Skid Base	250	3958	155.8	1440	56.7	1991	78.4	2857	6298.6
	300							2945	6492.6
	350	4633	182.4	1630	64.2	2227	87.7	3983	8781.0
	400							4017	8856.0
	450	4823	189.8	1630	64.2	2227	87.7	4408	9718.0
	500							4457	9826.0
	550	4980	196.1	1865	73.4	2172	85.5	4754	10480.8
	600							4837	10663.8
Sound Attenuated Enclosure on UL Listed Integral Fuel Tank Base	250	3958	155.8	1440	56.7	2487	97.9	3497	7709.6
	300							3585	7903.6
	350	4633	182.4	1630	64.2	2644	104.1	4765	10505.0
	400							4799	10580.0
	450	4823	189.8	1630	64.2	2777	109.3	5345	11783.7
	500							5394	11891.7
	550	4980	196.1	1865	73.4	2723	107.2	5973	13168.2
	600							6056	13351.2
Sound Attenuated Enclosure on UL Listed Extended Integral Fuel Tank Base	250	4608	181.4	1430	56.3	2379	93.7	3590	7914.6
	300							3678	8108.6
	350	5251	203.7	1620	63.8	2561	100.8	4876	10749.7
	400							4910	10824.7
	450	5909	232.6	1620	63.8	2612	102.8	5497	12118.8
	500							5546	12226.8
	550	6759	266.1	1865	73.4	2487	97.9	6237	13750.2
	600							6320	13933.2

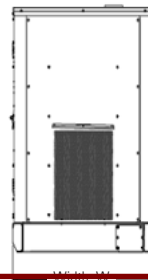
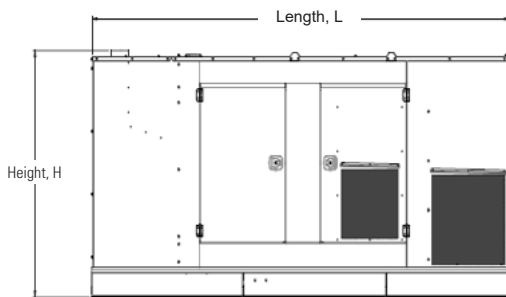

Sound Attenuated Enclosure on Skid Base

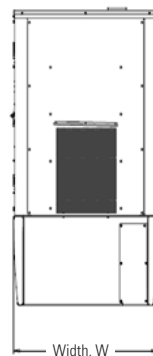
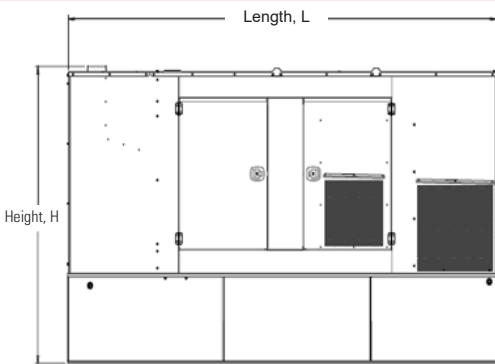

Sound Attenuated Enclosure on a UL Listed Integral Fuel Tank Base

Image shown may not reflect actual configuration

www.cat.com/electricpower

© 2026 Caterpillar

All rights reserved.

Materials and specifications are subject to change without notice.

The International System of Units (SI) is used in this publication. CAT, CATERPILLAR, LET'S DO THE WORK, their respective logos, "Caterpillar Corporate Yellow", the "Power Edge" and Cat "Modern Hex" trade dress as well as corporate and product identity used herein, are trademarks of Caterpillar and may not be used without permission.

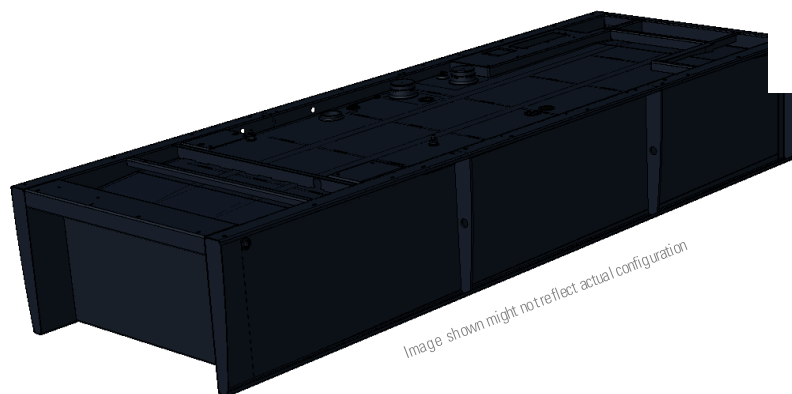

INTEGRAL FUEL TANKS

D250 GC – D600 GC

FEATURES

- UL Listed for United States (UL 142) and Canada (CAN/ULC S601)
- Facilitates compliance with NFPA 30 code, NFPA 37 and 110 standards and CSA C282 code
- Dual wall
- Low fuel level warning standard, customer configurable warning or shutdown
- Primary tank leak detection switch in containment basin
- Tank design provides capacity for thermal expansion of fuel
- Fuel supply dip tube is positioned so as not to pick up fuel sediment
- Fuel return and supply dip tube is separated by an internal baffle to prevent immediate re-supply of heated return fuel
- Pressure washed with an iron phosphate solution
- Interior tank surfaces coated with a solvent-based thin-film rust preventative
- Heavy gauge steel gussets with internal lifting rings
- Primary and secondary tanks are leak tested at 20.7 kPa (3 psi) minimum
- Compatible with open packages and enclosures
- Gloss black polyester alkyd enamel exterior paint
- Welded steel containment basin (minimum of 110% of primary tank capacity)
- Direct reading fuel gauge with variable electrical output
- Emergency vents on primary and secondary tanks are sized in accordance with NFPA 30.

INTEGRAL

- Integral diesel fuel tank is incorporated into the generator set base frame
- Robust base design includes linear vibration isolators between tank base and engine generator.

OPTIONS

- Audio/visual fuel level alarm panel
- 5gal (18.9 L) spill containment*
- Locking Fuel Fill
- Overfill prevention Valve*

*Applicable for D350GC-D600GC Models only

Integral Fuel Tank Base Useable Capacities with Fuel Tank Dimensions & Weights

Standby ekW	Width mm	Width in
250-300	1430	56.3
350-400	1630	64.1
450-500	1630	64.1
550-600	1865	73.4

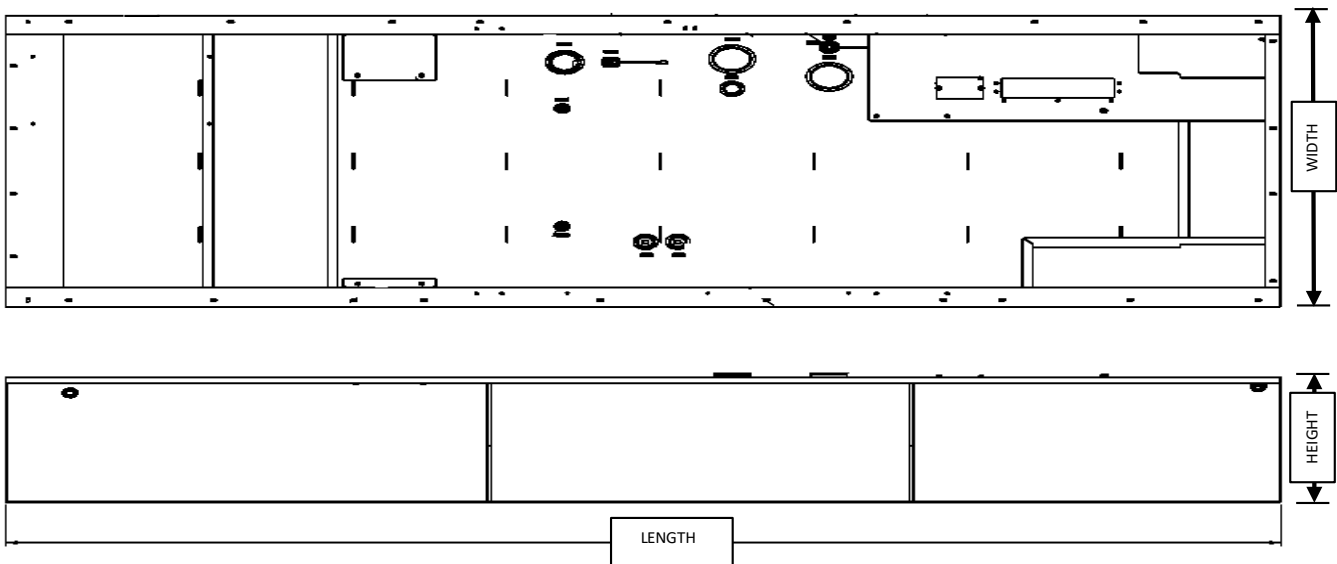

The heights listed above do not include lumber used during manufacturing and shipping

A. Open Set & Sound Attenuated Enclosure

Tank Design	Feature Code	Total Capacity		Useable Capacity		Tank Only						Overall Package Height with Tank			
						Dry Weight		Height 'H'		Length 'L'		Open		Enclosure	
		Litre	Gallon	Litre	Gallon	kg	lb	mm	in	mm	in	mm	in	mm	in
Integral Tank	FTDW035	2270.7	599.8	2059.9	543.9	970	2138	762.4	30.0	3958	155.8	2202	86.7	2487	97.9
	FTDW036	2820	744.9	2553	674.4	1165	2568	818.8	32.2	4625	182.1	2584	101.7	2644	104
	FTDW037	3671	969.7	3323	877.8	1331	2934	668.2	26.3	4622	181.9	2456	96.7	2644	104
	FTDW038	4292	1133.8	3889	1027.3	1657	3653	816.4	32.1	4980	196	2560	100.7	2721	107.1

B. Estimated Run Time (Hours)

Tank Design	Feature Code	Standby Ratings (kVA)						
		ekW	100%		75%		50%	
			Hrs	L/hr	Hrs	L/hr	Hrs	L/hr
Integral Tank	FTDW035	250	28.1	73.3	35	58.8	47	43.8
		300	24	86.0	30.8	66.8	40	51.5
	FTDW036	350	27.1	94.3	31.2	81.9	42.4	60.2
		400	24.1	105.9	28.1	90.7	38.6	66.2
	FTDW037	450	25.2	131.7	31.3	106.1	42.0	79.1
		500	24.3	137	30.1	110.5	46.6	71.3
	FTDW038	550	25.7	151.1	32.9	118.1	45.2	86.1
		600	24.1	161.6	30.0	129.6	42.4	91.7

Tanks with full electrical stub-up area include removable end channel. Tanks with RH stub-up include stubup area directly below the circuit breaker or power terminal strips.

Fuel tanks and applicable options facilitate compliance with the following United States NFPA Code and Standards:

NFPA 30: Flammable and Combustible Liquids Code

NFPA 37: Standard for the Installation and Use of Stationary Combustion Engines and Gas Turbines

NFPA 110: Standard for Emergency and Standby Power Systems

Fuel tanks and applicable options facilitate compliance with the following Canadian Standard and Code:

CSA C282 – Emergency Electrical Power Supply for Buildings

CSA B139-09 – Installation Code for Oil-Burning Equipment

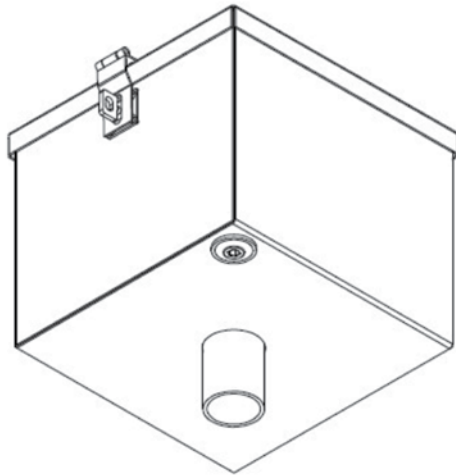

Image shown may not reflect actual configuration

5 Gallon Steel Spill Containment Box

Durable spill containment box designed for containment of small spills during filling of an above ground storage tank.

Features

- Optional overfill prevention valve
- Lockable hinged cover.

Dimensions

- Height: 13.08"
- Height with pipe: 13.40"
- Body Width: 12.38"
- Width: 13.68"
- Weight: 22 lbs.

www.Cat-ElectricPower.com

©2015 Caterpillar
All rights reserved.

Materials and specifications are subject to change without notice. CAT, CATERPILLAR, their respective logos, "Caterpillar Yellow", the "Power Edge" trade dress as well as corporate and product identity used herein, are trademarks of Caterpillar and may not be used without permission.

D250 GC - D600 GC

Dip Charts for Fuel Tanks

U.S. Sourced

Diesel Generator Set

250-600 kW 60 Hz

Integral Tanks

D250GC / D300GC Integral Fuel Tank FTDW035				D350GC / D400GC Integral Fuel Tank FTDW036			
Inches of Fuel on Dipstick	Measured Gallons	Inches of Fuel on Dipstick	Measured Gallons	Inches of Fuel on Dipstick	Measured Gallons	Inches of Fuel on Dipstick	Measured Gallons
0.5	12.8	14.5	371.2	0.5	17.2	14.5	498.8
1.0	25.6	15.0	384.0	1.0	34.4	15.0	516.0
1.5	38.4	15.5	396.8	1.5	51.6	15.5	533.2
2.0	51.2	16.0	409.6	2.0	68.8	16.0	550.4
2.5	64.0	16.5	422.4	2.5	86.0	16.5	567.6
3.0	76.8	17.0	435.2	3.0	103.2	17.0	584.8
3.5	89.6	17.5	448.0	3.5	120.4	17.5	602.0
4.0	102.4	18.0	460.8	4.0	137.6	18.0	619.2
4.5	115.2	18.5	473.6	4.5	154.8	18.5	636.4
5.0	128.0	19.0	486.4	5.0	172.0	19.0	653.6
5.5	140.8	19.5	499.2	5.5	189.2	19.5	670.8
6.0	153.6	20.0	512.0	6.0	206.4	20.0	688.0
6.5	166.4	20.5	524.8	6.5	223.6	20.5	705.2
7.0	179.2	21.0	537.6	7.0	240.8	21.0	722.4
7.5	192.0	21.5	550.4	7.5	258.0	21.5	738.2
8.0	204.8	22.0	563.2	8.0	275.2		
8.5	217.6	22.5	576.0	8.5	292.4		
9.0	230.4	23.0	588.8	9.0	309.6		
9.5	243.2	23.5	601.6	9.5	326.8		
10.0	256.0	24.0	614.4	10.0	344.0		
10.5	268.8	24.4	626.9	10.5	361.2		
11.0	281.6			11.0	378.4		
11.5	294.4			11.5	395.6		
12.0	307.2			12.0	412.8		
12.5	320.0			12.5	430.0		
13.0	332.8			13.0	447.2		
13.5	345.6			13.5	464.4		
14.0	358.4			14.0	481.6		

GCCP 1.2

Control Panel



Image shown may not reflect actual configuration.

Description

The controller is compatible with electronic (CAN) and non-electronic (magnetic pick-up/alternator sensing) engines and offer an extensive number of flexible inputs, outputs and extensive engine protections so the system can be easily adapted to meet the most demanding industry requirements.

The extensive list of features includes enhanced event and performance monitoring, remote communications & PLC functionality. The modules can be easily configured using a configuration suite PC software.

Full Range of Attachments

- Wide range of system expansion attachments, designed specifically to work with the GCCP controller
- Flexible packaging options for easy and cost effective installation

Benefits

- Hours counter provides accurate information for monitoring and maintenance periods
- User-friendly set-up and button layout for ease of use
- Multiple parameters are monitored & displayed simultaneously for full visibility
- The module can be configured to suit a wide range of applications for user flexibility
- PLC editor allows user configurable functions to meet user specific application requirements
- RS485 Communication port can be used for the Remote Monitoring Communication (Compatible with Cat PLG)

World Wide Product Support

- Cat dealers provide extensive pre and post sale support
- Cat dealers have over 1,600 dealer branch stores operating in 200 countries

GCCP 1.2 – Control Panel

GCCP 1.2 is an Auto Start Control Module suitable for a wide variety of diesel gen-set applications. Monitoring an extensive number of engine parameters, the modules will display warnings, shutdown and engine status information on the back-lit LCD screen, illuminated LEDs and remote PC.

Features

- 4-line back-lit LCD text display
- Multiple display languages
- Five-key menu navigation
- LCD alarm indication
- Customisable power-up text and images
- Data logging facility
- Internal PLC editor
- Protections disable feature
- Fully configurable via PC using USB & RS485 communication
- Front panel configuration with PIN protection
- Power save mode
- 3-phase generator sensing and protection
- Generator current and power monitoring (kW, kvar, kVA, pf) kW and kvar overload and reverse power alarms
- Over current protection
- Unbalanced load protection
- Breaker control via fascia buttons
- Fuel and start outputs configurable when using CAN Support for 0V to 10V & 4 mA to 20 mA sensors
- 8 Configurable digital inputs (3 available for Customer use)
- 8 Configurable digital outputs (5 available for Customer use)
- 4 Configurable analogue inputs (3 available for Customer use)
- CAN, MPU and alternator frequency speed sensing in one variant
- Real time clock
- Engine pre-heat and post-heat functions
- Engine run-time scheduler
- Engine idle control for starting & stopping
- Fuel usage monitor and low fuel level alarms
- 3 Configurable maintenance alarms
- MODBUS RTU support
- User configurable MODBUS pages

SPECIFICATIONS

DC SUPPLY

CONTINUOUS VOLTAGE RATING

8V to 35V continuous
5V for upto 1 minute

CRANKING DROPOUTS

Able to survive 0V for 100 mS, providing supply was at least 10V before dropout and supply recovers to 5V. This is achieved without the need for internal batteries.

LEDs and backlight will not be maintained during cranking

MAXIMUM OPERATING CURRENT

260 mA at 12V, 150 mA at 24V

MAXIMUM STANDBY CURRENT

145 mA at 12V, 85 mA at 24V

CHARGE FAIL/EXCITATION RANGE

0V to 35V

GENERATOR & MAINS (UTILITY) VOLTAGE RANGE

15V to 415 V AC (Ph to N)
26 V to 719 V AC (Ph to Ph)

MAGNETIC PICK-UP VOLTAGE RANGE

+/- 0.5 V to 70 V

FREQUENCY RANGE

10,000 Hz (max)

INPUTS

DIGITAL INPUTS A TO H

Negative switching

ANALOGUE INPUTS A TO D

Configurable as:

Negative switching digital input 0-10V sensor 4 mA to 20 mA
Resistive Sensor

ANALOGUE INPUTS A TO C

Configurable as:

Negative switching digital input Resistive Sensor

OUTPUTS

OUTPUT A and B (FUEL & START)

15 A DC at supply voltage

AUXILIARY OUTPUTS C, D, E, F, G, H, I & J 2

A DC at supply voltage

DIMENSIONS

OVERALL

216 mm x 158 mm x 43 mm
8.5" x 6.2" x 1.5"

PANEL CUTOUT

184 mm x 137 mm
7.2" x 5.3"

MAXIMUM PANEL THICKNESS

8 mm
0.3"

OPERATING TEMPERATURE

-30°C to +70°C
-22°F to +158°F

STORAGE TEMPERATURE RANGE

-40°C to +85°C
-40°F to +185°F

STANDARDS

UL, cUL Listed

NFPA 70#

Electro-Magnetic Compatibility: BS EN 61000-6-2/6-4 Electrical Safety: BS EN 60950

Temperature: BS EN 60068-2-1, BS EN 60068-2-2

Vibration: BS EN 60068-2-6

Humidity: BS EN 60068-2-30, BS EN 60068-2-78 Shock: BS EN 60068-2-27

Degrees of protection provided by enclosures: BS EN 60529 Ingress Protection: IP65 –
Front of module when installed into the control panel with the optional sealing gasket

Applicable codes and standards facilitate compliance to NFPA 70



Picture shown may not reflect actual configuration.

Remote Annunciator Module

It is an LED expansion module that can be used with compatible control modules. The module has been designed to display a maximum of eight individual LED indications up to a maximum distance of 1 KM (0.6 miles).

The Annunciator will consist of two modules to provide a 16 Channel Fault annunciation.

It is presented in a vertical enclosure. It includes an alarm sounder that is triggered when the host controller detects an alarm condition. The alarm can be muted using the front push button.

The Panels will be fitted with removable label cards which can be used to identify the standard NFPA alarms if desired.

It includes individual LEDs for each channel and a 'Power On' LED that flashes when the link with the host controller is lost.

Features

- The Remote annunciator has an integral Sounder/Horn
- Eight configurable LEDs (per module)
- Works up to 1 KM (0.6 miles) from the host controller
- A single controller can support five Caterpillar configured remote annunciator control boxes

ENVIRONMENTAL TESTING STANDARD

ELECTRO-MAGNETIC COMPATIBILITY

BS EN 61000-6-2
EMC Generic Immunity Standard for the Industrial Environment
BS EN 61000-6-4
EMC Generic Emission Standard for the Industrial Environment

ELECTRICAL SAFETY

BS EN 60950
Safety of Information Technology Equipment, including Electrical Business Equipment

TEMPERATURE

BS EN 60068-2-1
Ab/Ae Cold Test -30 °C BS EN 60068-2-2
Bb/Be Dry Heat +70°C

VIBRATION

BS EN 60068-2-6
Ten sweeps in each of three major axes
5 Hz to 8 Hz @ +/-7.5 mm, 8 Hz to 500 Hz @ 2 gn

SHOCK

BS EN 60068-2-27
Three shocks in each of three major axes 15 gn in 11 Ms

HUMIDITY

BS EN 60068-2-30
Db Damp Heat Cyclic 20/55 °C @ 95% RH 48 Hours
BS EN 60068-2-78
Cab Damp Heat Static 40 °C @ 93% RH 48 Hours

DEGREES OF PROTECTION PROVIDED BY ENCLOSURES BS EN 60529

IP65 – Front of module when installed into the control panel with the supplied sealing gasket.

SPECIFICATION

CONTINUOUS VOLTAGE RATING

8 V to 35 V Continuous

CRANKING DROPOUTS

Able to survive 0 V for 50 mS, providing supply was at least 10 V before dropout and supply recovers to 5 V. This is achieved without the need for internal batteries. LEDs and backlight will not be maintained during cranking.

MAXIMUM OPERATING CURRENT

112 mA at 12 V, 53 mA at 24 V

MAXIMUM STANDBY CURRENT

74 mA at 12 V, 35 mA at 24 V

DIMENSIONS OVERALL

355 mm x 369 mm x 90 mm
13.6" x 14.5" x 3.5"

PANEL CUT-OUT

286 mm x 326 mm x 93 mm
11.2" x 12.8" x 3.6"

MAXIMUM PANEL THICKNESS

8 mm
0.3"

LET'S DO THE WORK.™

Remote Annunciator Drawing

METRIC PART # 578-4983

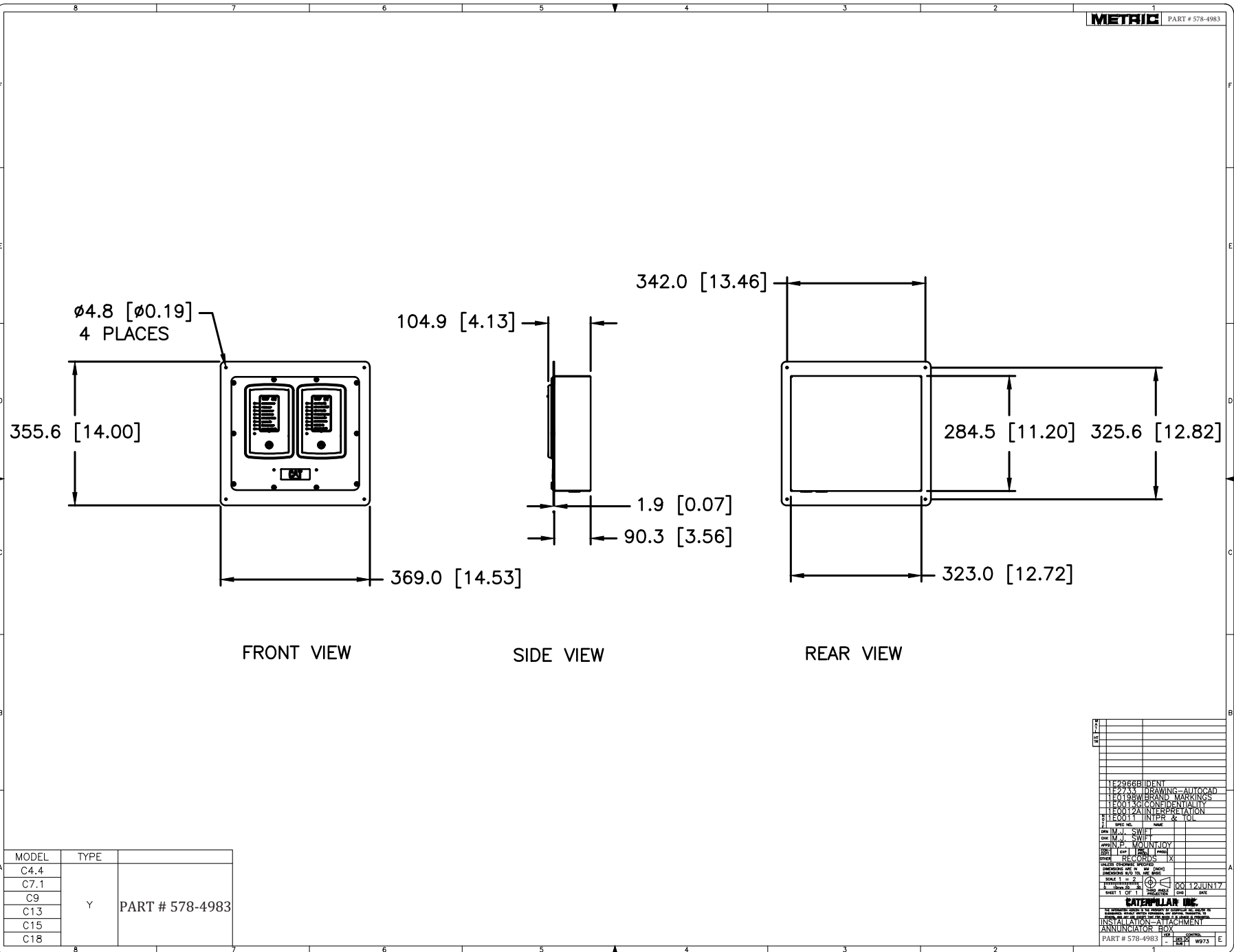

MODEL	TYPE	
C4.4	Y	PART # 578-4983
C7.1		
C9		
C13		
C15		
C18		

DATE	
REV	
DESCRIPTION	
DESIGNED BY	
DRAWN BY	
CHECKED BY	
APPROVED BY	
DATE	
SCALE	1:1
CATERPILLAR INC.	
PART # 578-4983	

PANELSOURCE P6-16-DS ANNUNCIATOR PANEL

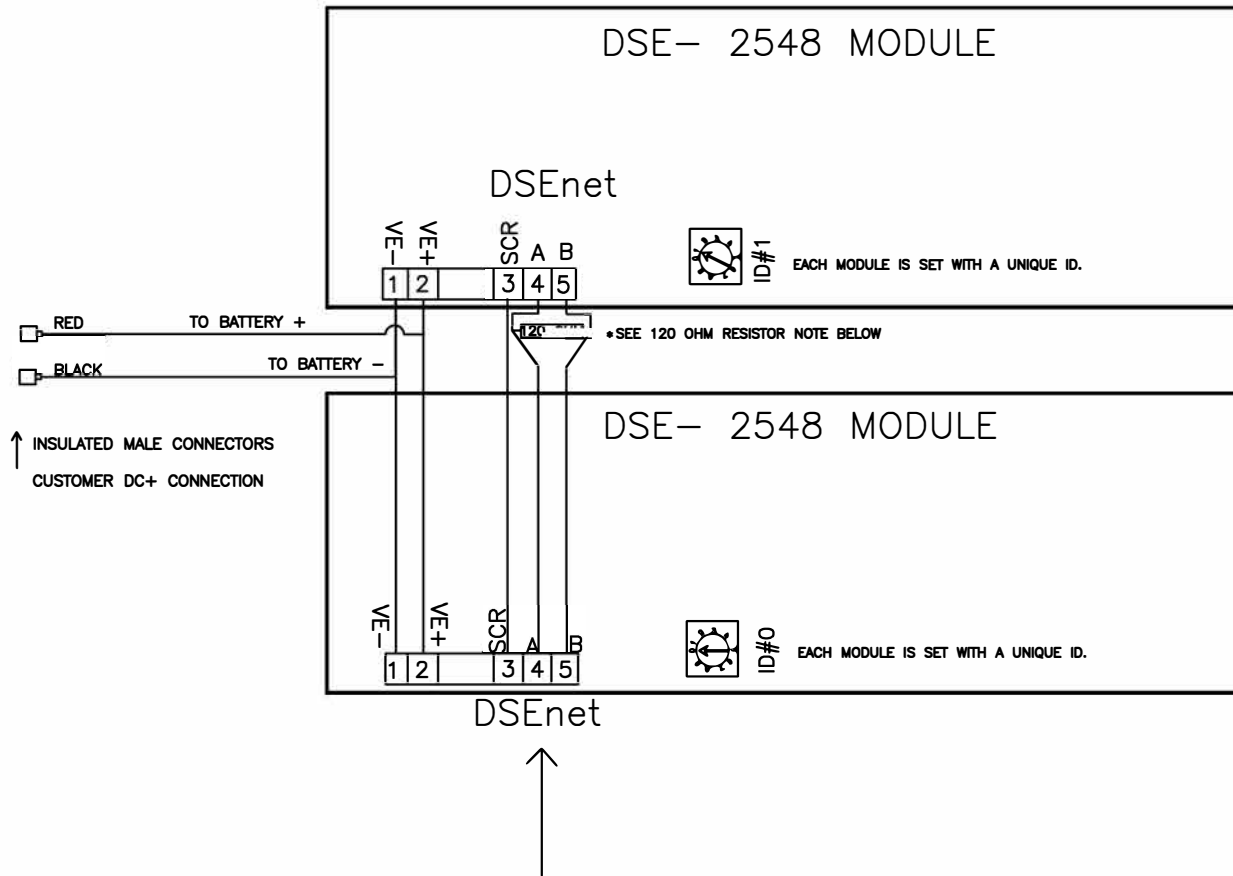

(2) Pairs of 14 AWG THHN & 9841 Cable is Recommended By Thompson CAT

Customer Communication Cable Connection Point.
Belden 9841 OR 9271 Direct equivalent 120ohm rated twisted pair cable must be used.

See host controller operator manual or panelsource DC schematic for DSEnet terminal numbers.

REQUIRES DEEP SEA CONFIGURATION SUITE PC SOFTWARE TO CONFIGURE

DSE-2548 LED Expansion Module(s) configured through compatible DSE host controller (EX. DSE-7310MKII, DSE-7410MKII, DSE-8610II, etc)

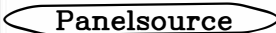
<p>————— WIRED BY PANELSOURCE - - - - - WIRED BY CUSTOMER</p>	<p>* 120 OHM RESISTOR SEE "DSE NET FOR EXPANSION MODULES" IN CONTROLLER OPERATORS MANUAL</p>	<p>UNLESS OTHERWISE SPECIFIED: ALL DC WIRES 16AWG. RELAY JUMPERS 18AWG COM CABLE - BELDEN 9841</p> <p>SCALE: NOT TO SCALE</p>	 ENGINE & GENERATOR CONTROLS	<p>TITLE: P6-16-DS</p> <p>DRAWING NUMBER: P6-16-DS</p>	<p>ORIG. DATE: 23-JUN-014</p> <p>DRAWN BY: TE</p>	<p>LAST REV. DATE: 01-OCT-018</p> <p>REVISION: REV2.0</p> <p>SHEET 1 OF 1</p>
--	--	---	--	--	---	--

Circuit Breakers [C9, C13, C15, C18]

D250 GC, D300 GC, D350 GC, D400 GC, D450 GC, D500 GC, D550 GC, D600 GC

Manually Operated Circuit Breakers

Current (A)	Frame	Number of Poles	Interrupting Ratings (kA ms)			Trip Unit	(Lugs) Cable Size Range / Phase	Auxilliary Options
			240V	480V	600V			
100	XT2	3	65	25	18	Electronic LS/I or LSI	14-1/0 AWG	1 Form C + 1 Bell Alarm Shunt Trip 24VDC
250	XT4	3	65	25	18	Electronic LS/I or LSI	14-1/0 AWG	1 Form C + 1 Bell Alarm Shunt Trip 24VDC
400	XT5	3	65	35	18	Electronic LS/I or LSI	2/0 – 500 kcmil	1 Form C + 1 Bell Alarm Shunt Trip 24VDC
600	XT6	3	65	35	20		(3) 2/0 – 400 kcmil	
800	XT6	3	65	35	20		(3) 2/0 – 400 kcmil	
1200	XT7	3	65	50	25		(4) 4/0 – 500 kcmil	1 Form C + 1 Bell Alarm Shunt Trip 24VAC/VDC

1st Breaker Options (400 – 1200A)

Model	Current (A)	Operation
C9, C13, C15	400	Manually Operated
C9, C13, C15, C18	600	Manually Operated
C9, C13, C15, C18	800	Manually Operated
C9, C18	1200	Manually Operated

1st Breaker FLC Capacity or one frame less than FLC capacity except when 1st breaker is 400 A.

2nd Breaker Options

Model	Current (A)	Operation
C9, C13, C15, C18	100 / 250	Manually Operated

2nd Breaker either 100A or 250A.

XT6 Ekip Dip LSI L-S-I Functions

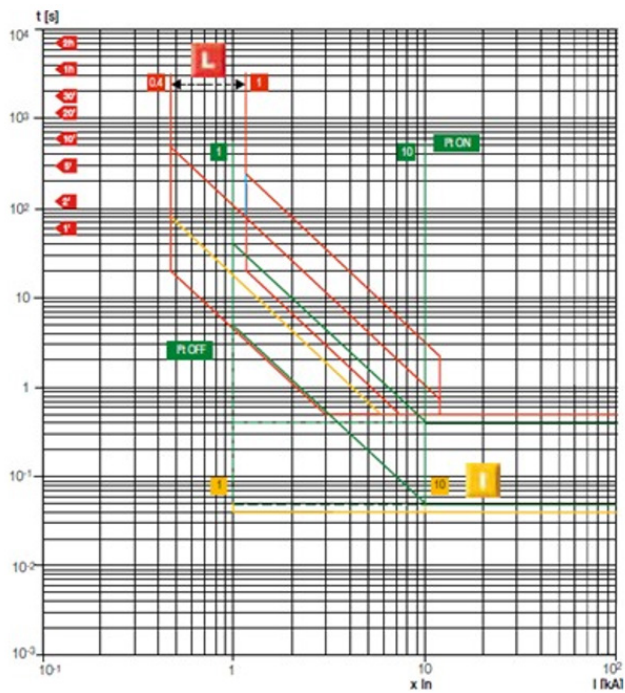

Figure 5

XT5 – XT6 Ekip Dip LS/I L-S-I Functions

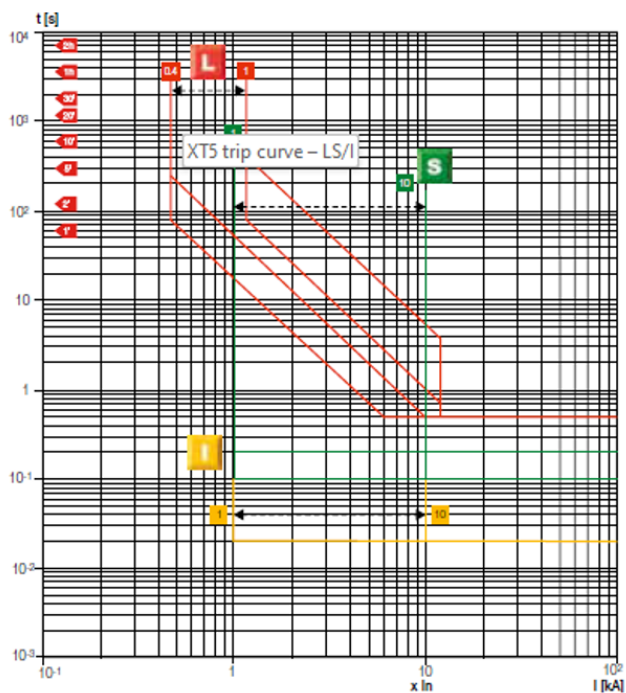

Figure 6

100 Amp Load Center



Image shown may not reflect actual package.

100 Amp Load Center

Specifications	
Number of Spaces	6
System Voltage	120 / 240VAC
Number of Tandem Circuit Breakers	6
Phase	1 Ph
NEMA Degree of Protection	NEMA 3R Outdoor
Electrical Connection	Lugs
Wiring Configuration	3-Wire
Material	Tin Plated Aluminum Busbar
Enclosure Material	Welded Galvanized Steel Gray
Cover Finish	Baked Enamel
Product Certifications	UL E-6294
Gauge	AWG 8...AWG 1 (Aluminium / Copper)

Dimensions and Load Ratings	
Height / Width / Depth	321 mm / 226 mm / 127 mm
GFCI	20A (120V)
Battery Charger	6A (120V)
Jacket Water Heater	15A (120V)
Alternator Heater	2.1A (120V)
Total Load	43.1A Max

L1	
GFCI	20A (120V)
Jacket Water Heater	15A (120V)
Alternator Heater	2.1A (120V)
Total Load	37.1A Max

L2	
Battery Charger	6A (120V)
Jacket Water Heater	15A (120V)
Alternator Heater	2.1A (120V)
Total Load	23.1A Max

LET'S DO THE WORK.™

www.cat.com/electricpower

©2024 Caterpillar

All rights reserved.

Materials and specifications are subject to change without notice.

The International System of Units (SI) is used in this publication. CAT, CATERPILLAR, LET'S DO THE WORK, their respective logos, "Caterpillar Corporate Yellow", the "Power Edge" and Cat "Modern Hex" trade dress as well as corporate and product identity used herein, are trademarks of Caterpillar and may not be used without permission.

LED Lights



Image shown may not reflect actual package.

Features

AC/DC Lighting Kit

- Capable of AC and DC operation with provided selector switch
- DC operation has a 60-minute timer switch to limit battery drain
- AC operation is enabled by transformer
- Low voltage, low energy circuit and operation
- Installation includes one single LED light.

Technical Data	
Theoretical Lumens Output	1600 lm
Operational Lumens Output	1000 lm
Color Temperature	5700 K
Lens	PC
Body	Aluminum
Weight	0.6 kg
IP Rating	IP68, IP6K9K
EMC	CISPR 25 Class 3, EN 12895, ISO 13766, ISO 14982, ISO 7637-2
Operating Temperatures	-40°C to +85°C (Overheat protected)

www.Cat-ElectricPower.com

©2022 Caterpillar
All rights reserved.



Image shown may not reflect actual configuration.

20A Tamper-Resistant, Weather-Resistant GFCI Receptacles

Features and Benefits

- Automatically tests the GFCI every time the reset button is pushed in. The GFCI will not reset if the GFCI circuit is not functioning properly.
- By blocking reset of the GFCI if protection has been compromised, SmartLockPRO reduces the possibility of end-users incorrectly assuming that a reset GFCI outlet is providing ground fault protection when it actually is not.
- A line-load reversal diagnostic feature is provided which prevents the GFCI from being reset and stops power from being fed to the GFCI receptacle face or through to downstream devices. A green LED indicator on the GFCI's face also illuminates to alert the installer to the line-load wiring reversal.

Weather-Resistant GFCIs

- Meet UL 498 requirements for weather-resistant receptacles.

Tamper-Resistant GFCIs

- Shutter mechanism inside the receptacle blocks access to the contacts unless a two-prong plug is inserted, helping ensure foreign objects will be locked out.

Product Features

- Grounding: GFCI ground fault
- Feature: Weather and tamper-resistant
- Amperage: 20 Amp
- Voltage: 125 Volt
- NEMA: 5-20R
- Trip Level: Class A, 5mA plus or minus 1mA
- Pole: 2
- Wire: 3
- Color: White

Standards and Certifications

- NEMA: WD-6
- ANSI: C-73
- UL498: File E13399
- CSA C22.2 No. 42: File LR-57811
- NOM: 057
- UL 943: File E48380

Receptacles contained in a weather resistant box and in-use cover.



www.Cat-ElectricPower.com

©2016 Caterpillar
All rights reserved.

Materials and specifications are subject to change without notice.

CAT, CATERPILLAR, their respective logos, "Caterpillar Yellow", the "Power Edge" trade dress as well as corporate and product identity used herein, are trademarks of Caterpillar and may not be used without permission.



Remote Emergency Stop Button

Image shown may not reflect actual configuration.

Features and Benefits

- Enclosure degree of protection – IP 69K (NEMA 6)
- UL Listed (NKCR)
- Assembled enclosure with shroud
- 40 mm mushroom emergency stop
- Twist release
- 2NC – horizontally mounted

Dimensions

- Net Width: 0.065 m
- Net Height: 0.078 m
- Net Depth: 0.065 m
- Net Weight: 0.124 kg

www.Cat-ElectricPower.com

©2020 Caterpillar

All rights reserved.

Materials and specifications are subject to change without notice.
CAT, CATERPILLAR, LET'S DO THE WORK, their respective logos, "Caterpillar Corporate Yellow", the "Power Edge" and Cat "Modern Hex" trade dress as well as corporate and product identity used herein, are trademarks of Caterpillar and may not be used without permission



Jacket Water Heater (WHHH01/WHHH03)

Appropriate when the generator set is to be sited in a low ambient environment, the heater maintains the engine coolant at a temperature [typically 38°C (100°F)] which facilitates rapid starting and load acceptance. The heater assembly uses UL compliant components (to UL1030) and has CSA certification which is to both CSA and UL Standards.

The heater itself is powered by a 240V for 60 Hz AC auxiliary supply. A thermostatic controller is included to regulate the output temperature to within safe limits. When the generator set is not running the heater is automatically connected to the AC supply through a power relay mounted in the control panel.

Upon receiving a start signal the AC supply is automatically disconnected by the power relay and automatically reconnected when the start signal is removed, and the engine has stopped.

Features

- Uniform heat distribution
- Reduces wear from cold spots
- Improves startability
- Thermostatically controlled and protected
- 6' (1.8m) cord length (577-1758)
- 16.4' (5.0m) cord length (578-9355).
- Ensures generator is at optimal starting temperature and ready to accept load
- Durable pump with non-magnetic impeller that does not attract metal debris
- Robust die cast aluminum housing improves sealing of the hoses, eliminates leaking and breakage
- Corrosion resistant steel brackets for superior strength and durability
- Reduces thermal stress on coolant hoses
- Element designed for long life with maximum heat transfer
- IP44 Ingress Protection Rating
- No evaporation of coolant from hoses
- Reduces low coolant level alarms because coolant does not boil

Part No	Outlet Location	Watts	Volts	Amps	Regulating Thermostat	Safety Thermostat
577-1758/578-9355	Right	2700	240	11.25	On 90°F (32°C) Off 115°F (46°C)	210°F (98°C)

www.cat.com/electricpower
©2020 Caterpillar
All rights reserved.

Information contained in this publication may be considered confidential. Discretion is recommended when distributing. Materials and specifications are subject to change without notice.

CAT, CATERPILLAR, LET'S DO THE WORK, their respective logos, "Caterpillar Corporate Yellow," the "Power Edge" and Cat "Modern Hex" trade dress as well as corporate and product identity used herein, are trademarks of Caterpillar and may not be used without permission.



Image shown might not reflect actual configuration.

BATTERY CHARGER

The intelligent battery charger has been developed with safety, usability, optimised battery performance and maximum battery lifetimes in mind.

A comprehensive range of input and output protections ensures a continued safe charging environment also enabling the use of the charger as a power supply.

FEATURES

- Intelligent two, three and four stage charging profiles
- Configurable to suit most battery types (12V/24V)
- Adjustable current limit
- Can be used as a battery charger, power supply or both at the same time
- Automatic or Manual boost and storage charge functions to help maintain battery condition
- Digital Microprocessor Technology
- Temperature compensation for battery charging
- Low Output Ripple and superb line regulation
- Three LED Indicators
- AC input Under voltage
- AC input Over voltage
- Battery charger output Over voltage
- Battery charger output Over current
- Optional battery temperature compensation with over temperature protection
- Output short circuit and Inversion polarity with auto recovery
- Configurable charge termination
- UL1236 /UL1564 Compliant

Automatic Boost Mode

- Boosts and equalises cell charge improving battery performance and life

Power Save Mode

- Once the battery is fully charged the chargers switch to Eco-Power to save energy

Communication

- Can be integrated into external systems through MODBUS RTU using RS485
- Fully configurable via PC Software

BENEFITS

- Fully flexible to maximise the life of the battery
- Suitable for a wide range of battery types
- Switched mode design
- Minimum 86% efficiency throughout full operating range
- No external intervention for boost mode
- Multiple chargers can be linked together to provide larger current output
- Can be permanently connected to battery and mains (utility) supply. No need to disconnect through high load conditions.

SPECIFICATION

AC SUPPLY

VOLTAGE RANGE 90 V to 305 V (L-N)

FREQUENCY RANGE

48 Hz to 64 Hz (L-N)

DC OUTPUT RATING

10 A DC at 24 V DC

RIPPLE AND NOISE

<1%

EFFICIENCY

>86%

REGULATION LINE

<0.5%

LOAD

2%

TEMPERATURE SENSOR INPUT

PT1000

PROTECTIONS

Short Circuit
DC Over Voltage
DC Over Current
Reverse Polarity
Over Temperature
AC Under & Over Voltage

CHARGE FAILURE RELAY

3 A at 30 V DC volt free relay

DIMENSIONS OVERALL

70 mm x200 mm x 130 mm
2.7" x 7.9" x 5.1"

WEIGHT

0.75 kg

OPERATING TEMPERATURE RANGE

-30 °C to +80 °C
-22 °F to +176 °F

STORAGE TEMPERATURE RANGE

-30 °C to +80 °C
-22 °F to +176 °F

www.cat.com/electricpower

©2024 Caterpillar
All rights reserved.

Materials and specifications are subject to change without notice.

The International System of Units (SI) is used in this publication. CAT, CATERPILLAR, LET'S DO THE WORK, their respective logos, "Caterpillar Corporate Yellow" the "Power Edge" and Cat "Modern Hex" trade dress as well as corporate and product identity used herein, are trademarks of Caterpillar and may not be used without permission.

Cat[®] Batteries



Cat[®] Batteries—Greater Starting Power— Lower Maintenance—Longer Life

Cat Premium High Output (PHO) batteries are used in all Cat Machines and Engine Gen-Sets. They are designed to meet stringent Caterpillar design specifications, which provide industry leading cold cranking amps (CCA) capability and maximum vibration resistance.

Maintenance Free Accessible or low maintenance designs are available in wet and dry configurations.

General Service Line batteries are available in Maintenance Free Accessible or low maintenance designs. Wide selections of BCI group sizes are available for automotive, light truck, bus, industrial, agricultural, marine, recreational and valve regulated (VRLA-AGM & Gel) applications.



World's Toughest Batteries



Premium High Output—Maximum Vibration Resistance

- Vibration Resistance...five times the Industry Standard
- Exclusive "flat top" BCI group 4D & 8D batteries are Maintenance Free Accessible and have the industries highest cold cranking amps (CCA)
- Popular BCI group 31 Maintenance Free Accessible batteries with industry leading cold cranking amps...up to 1000 (CCA), for electric power, machine or on-highway truck and bus applications. Deep cycle models are available for truck, marine or recreational usage

Specifications for Cat Premium High Output Batteries-Available Worldwide

BCI Group Size	Part No.	CCA ≈	RC Mins †	Volts	Amp Hr. Capacity @ 20 Hrs.	Construction Notes	Accessibility - Fluid Level Check Hours	Length In (mm)	BCI Overall Dimensions		Nominal Weight		
									Width In (mm)(mm)	Height In (mm)	Wet Lb (kg)	Dry Lb (kg)	Nominal Acid to Fill Qt (liter)
8D	153-5720	1500	465	12	210	C/MFA	A - 1000	20.5 (520)	10.8 (275)	9.8 (248)	132 (59.9)	-	-
8D	101-4000	1400	400	12	190	LAC+	A - 1000	20.8 (527)	11.0 (278)	9.8 (248)	132 (59.9)	86 (39.0)	18.0 (17.0)
4D	153-5710	1400	425	12	200	C/MFA	A - 1000	20.5 (520)	8.6 (218)	9.8 (248)	119 (54.0)	-	-
4D	9X-9730	1300	400	12	190	LAC+	A - 1000	20.8 (527)	8.6 (218)	9.8 (248)	120 (54.0)	81 (36.8)	14.8 (14.0)
4D	153-5700	1125	305	12	145	C/MFA	A - 1000	20.5 (520)	8.6 (218)	9.8 (248)	101 (45.8)	-	-
4D	9X-9720	1000	275	12	140	LAC+	A - 1000	20.8 (527)	8.6 (218)	9.8 (248)	102 (45.8)	59 (26.8)	15.9 (15.0)
31	175-4390	1000	180	12	90	C/MFA/S	A - 1000	12.9 (329)	6.8 (172)	9.3 (236)	60 (27.2)	-	-
31	175-4370	825	190	12	100	C/MFA/S**	A - 1000	12.9 (329)	6.8 (172)	9.3 (236)	61 (27.2)	-	-
31	175-4360	710	185	12	100	C/MFA/S***	A - 1000	12.9 (329)	6.8 (172)	9.3 (236)	62 (28.1)	-	-
31/30H	115-2422	1000	170	12	90	C/MFA	A - 1000	12.9 (329)	6.8 (172)	9.5 (241)	63 (28.6)	-	-
31/30H	115-2421	950	170	12	90	C/MFA+	A - 1000	12.9 (329)	6.8 (172)	9.5 (241)	64 (29.1)	44 (20.0)	6.6 (6.2)
31/30H	9X-3404(1)	950	165	12	95/100	C/MF	NA	13.0 (331)	6.8 (172)	9.5 (241)	58 (26.3)	-	-
31/30H	31-5760	750	165	12	95/100	C/MF	AV - 1000	13.0 (331)	6.8 (172)	9.5 (241)	56 (25.4)	-	-
65	230-6368	880	140	12	70	C/MF	NA	11.9 (304)	7.5 (191)	7.5 (191)	46 (20.9)	-	-
24	153-5656	650	110	12	52	C/MF	NA	11.0 (279)	6.9 (174)	9.0 (229)	39 (17.7)	-	-

Construction Notes:

Batteries use SAE taper post design and are shipped wet except as:

- LAC = Low Maintenance - Hybrid Construction
- C = Calcium Lead Alloy Grid Design
- MF = Maintenance Free Non-Accessible
- MFA = Maintenance Free Accessible
 - A = Accessible
 - NA = Non-Accessible
 - AV = Accessibly Varies - Accessibility varies depending on supplier used. If it has caps, it is accessible and fluid levels should be checked.
 - S = Stud Terminals
 - + = Shipped Dry Only
 - * = Side Terminals Only
 - ** = Starting and Deep Cycle Battery
 - *** = Deep Cycle and Starting Battery
 - ≈ = Cold Cranking Amps for 30 seconds at 0° F (-18° C)
 - † = Reserve Capacity Minutes minimum of 25 amp output at 80° F (27° C)
- SDT = Dual, Top mounted Terminals - Stud and SAE Post. Marine Deep Cycle/Starting Battery
 - 1 = Available in EAME and China only

Rugged Design—Built Tough—Reliable Starting

- Positive and negative plates are anchored to container bottom and locked at the top of cell element for maximum vibration resistance.
- Heavy-duty forged terminal post bushings provide maximum strength and resistance to acid seepage.
- Hefty full-frame grids, no sharp edges, optimum acid/paste combination provides better charge acceptance after deep discharge.
- Manifold vented cover with built-in Flame Arrestor... a safety feature that directs corrosive gases away from the battery and hold-downs.
- Thick, robust container resists rugged treatment typical of heavy-duty commercial use. Embossed part number & descriptors for easy serviceability.

BCI Terminal Locations

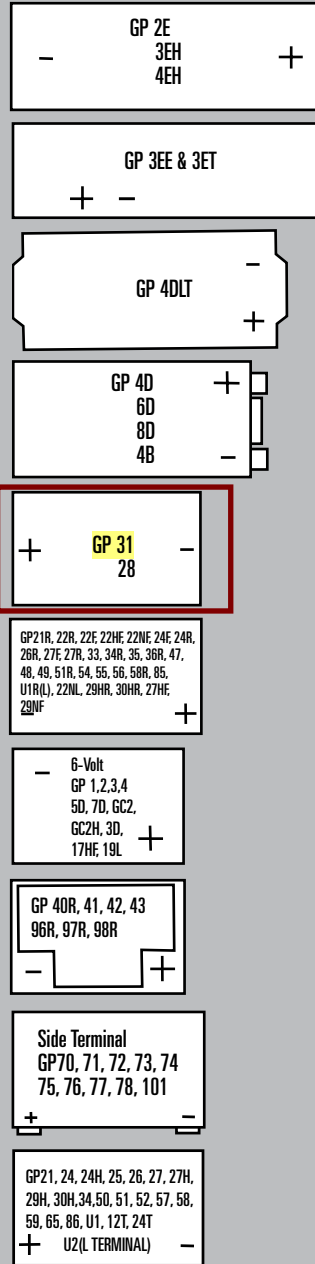

Transit Bus Terminal for 8D Part # 250-0473
One piece end terminal.
Right end of Battery.
1/2" - 13 Steel Positive Stud
3/8" - 16 Steel Negative Stud
Terminal not serviceable

Type B

Cat Premium High Output Batteries — Built Tough to Exceed Demanding Performance Test Requirements:

- 100 hour Vibration Testing – Five Times the Industry Standard**
 Battery must be able to withstand vibration forces without suffering mechanical damage, loss of capacity, loss of electrolyte or without developing internal/external leaks
 Battery must pass a high rate discharge test after the vibration testing
- Five 72-hour Deep Discharge/Recharge Test Cycles**
 Battery must recover to 25 charging amps within 20 minutes and meet Industry Electrical Performance Standards
- 30 Day Complete Discharge Test**
 Battery must recover to 25 charging amps within 60 minutes and meet Industry Electrical Performance Standards after recharging
- SAE J2185 Life Cycle Test**
 Battery subject to deeper discharge and charge cycles at extreme temperatures not normally encountered in starting a machine or vehicle
- Cold Soak Test**
 Battery cold soaked at sub-freezing temperatures and then tested by starting an equally cold engine



Battery Accessories

Group 31 - Charging Posts for Stud Terminals - Part # 4C-5637
 Screw-in Charging Posts for Side Terminals - Part # 4C-5638
 Wing Nut - Part # 2B-9498 for Part #'s 175-4390/175-4370/175-4360/8C-3628
 Wing Nut - Part # 3B-0723 for Part #'s 8C-3638 and 8C-3639
 Booster Cable 12' (3.66 m) - Part # 4C-4911
 Booster Cable 20' (6.00 m) - Part # 4C-4933
 Heavy Duty Commercial Fast Charger (110V) - Part # 4C-4921
 Heavy Duty Commercial Fast Charger (220V) - Part # 4C-4910

Note: Ratings and Part Numbers are subject to change without notice.

Recycle all scrap batteries.
We accept lead-acid batteries for recycling.



Marine Commercial Vessels

Maintenance Free Accessible 4D, 8D and Group 31 Batteries. General Service Line Valve regulated (VRLA) Gel batteries. High Marine Cranking Amps (MCA) and Deep Cycling capabilities.



Marine Pleasure Craft

Premium High Output BCI Group 31, Dual Terminal Deep Cycle Batteries. General Service Line BCI group 24M, 27M and 8V sizes.



Automotive-Truck-Bus & RV

A wide selection of popular BCI group sizes. Maintenance Free Accessible, Severe Service and Deep Cycle models. Application Specific Group 31 Truck Batteries.



Electric Power Generation

Premium High Output Maintenance Free Accessible and Accessible batteries in BCI group 4D, 8D, & 31 sizes. High Cold Cranking Amp (CCA) Capability. General Service Line valve regulated (VRLA) GM batteries for UPS or stationary power applications.



Commercial & Recreational

A wide selection of premium batteries in most BCI group sizes for light commercial, recreational, agricultural and industrial applications.



Construction & Mining

Premium High Output Maintenance Free Accessible batteries. BCI group 4D, 8D and 31 Sizes. Industry leading cold cranking amps (CCA) and maximum vibration resistance.

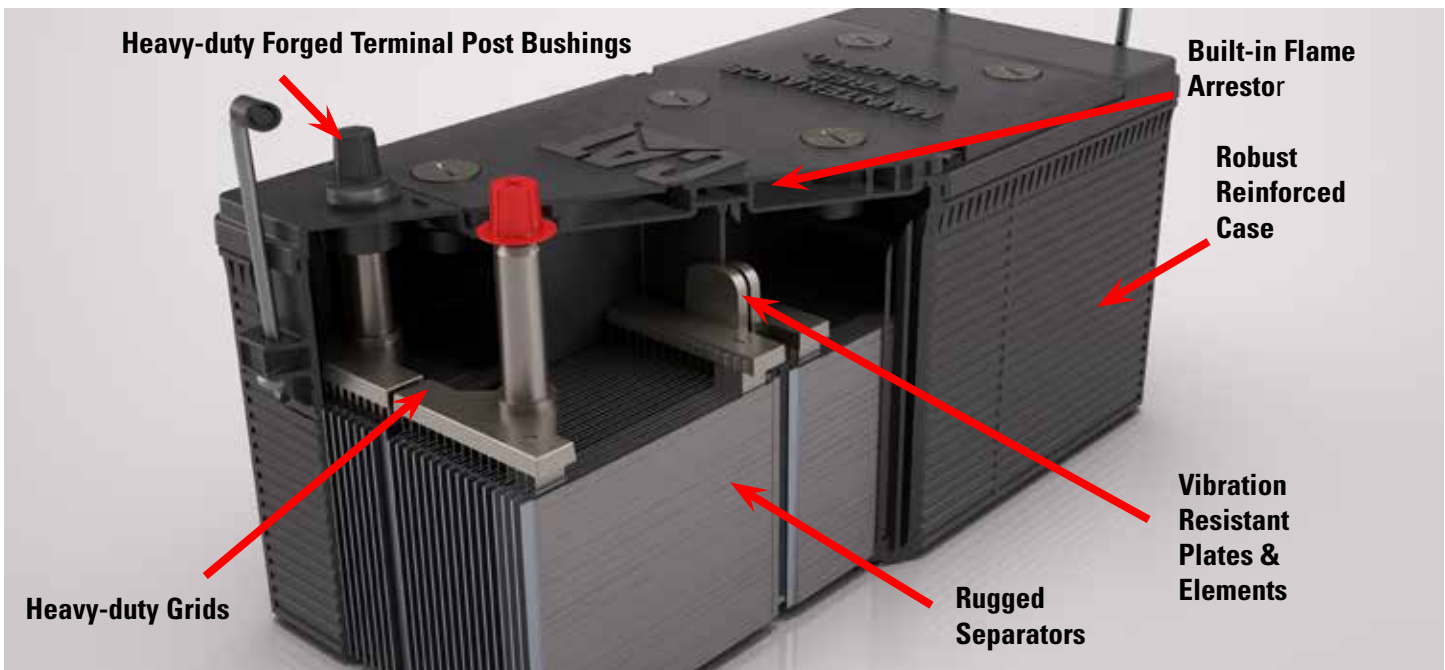

Robust Components = Long Life + Reliable Starts

- Heavy-duty forged terminal post bushings provide maximum strength and resistance to acid seepage that causes corrosion and black posts. Thicker internal terminal posts provide lower electrical resistance and higher cold cranking amp output.
- Rugged micro porous polyethylene envelope separators protect against “shorts” and vibration damage. Deep Cycle batteries utilize double insulated Glass mat separators for longer cycling life.
- Maintenance Free Accessible batteries utilize calcium lead alloy on both positive and negative plates that reduces gassing and water consumption. Automotive batteries have Silver (Ag) Calcium Alloy Grids for resistance to high underhood temperatures.
- Heavy-duty, full frame battery grids with no sharp edges. An optimum acid/paste combination provides better charge acceptance after a deep discharge.
- Positive and Negative plates are anchored to the container bottom and the cell element is locked at the top for maximum vibration resistance. Straps are thicker, heavier and cast (not welded) into the plates.
- Manifold vented cover with built-in Flame Arrestor... a safety feature that directs corrosive gases away from the battery and hold-downs.
- Robust reinforced case provides extra strength in all temperature extremes. Brickwork design on sides reduces chance of punctures and case flexing. Embossed part number and descriptors for easy serviceability.

CAT DEALERS DEFINE WORLD-CLASS PRODUCT SUPPORT.

We offer you the right parts and service solutions, when and where you need them.

The Cat Dealer network of highly trained experts keeps your entire fleet up and running to maximize your equipment investment.



Estimated DRY Weight Includes: Gen – Enc = 10,580 lbs.

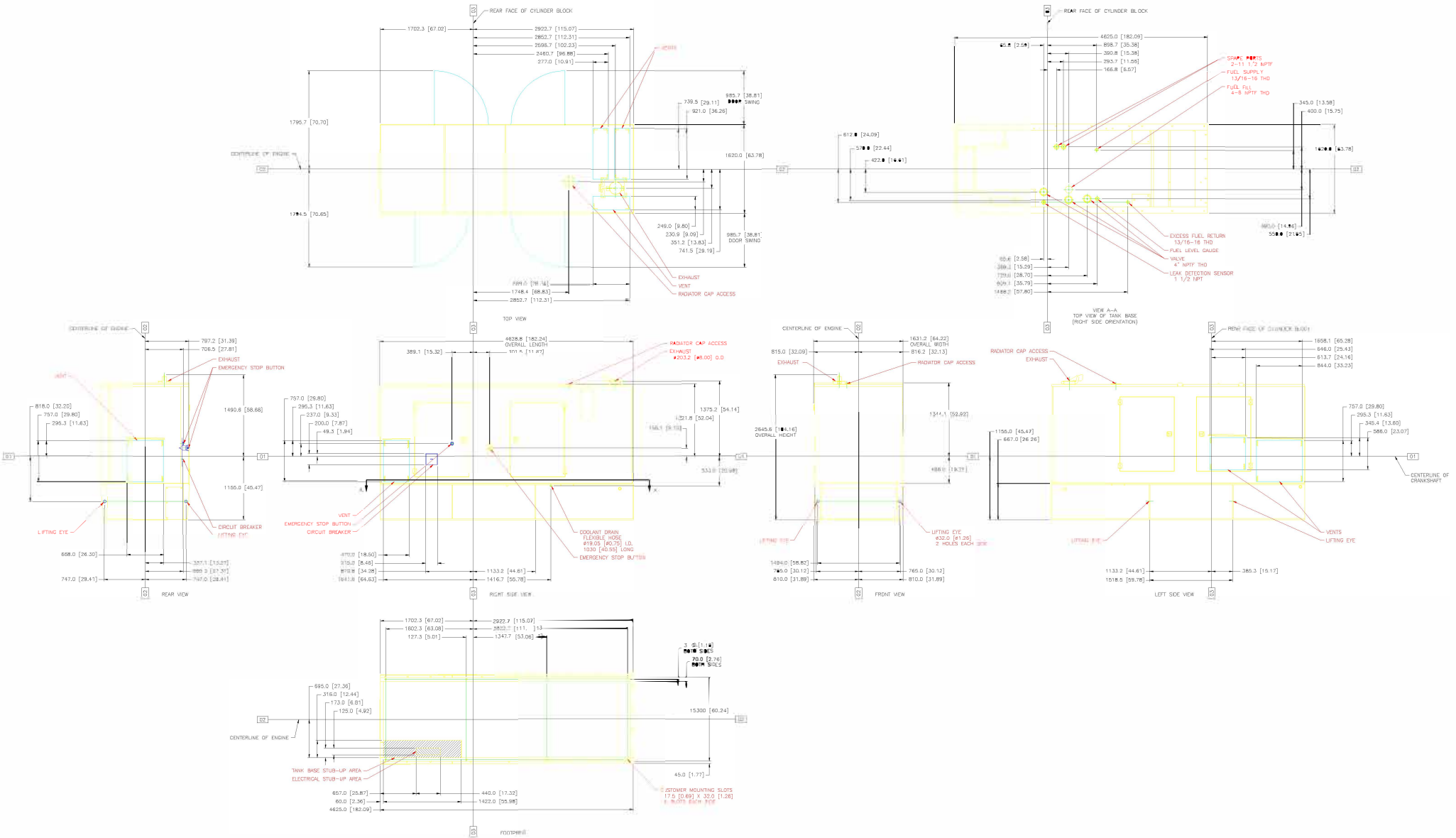

Estimated DRY Weight Includes: Gen – Enc = 10,580 lbs.

TOP VIEW - ELECTRICAL STUB-UP

USE THIS DRAWING WHEN LAYING OUT CONDUIT

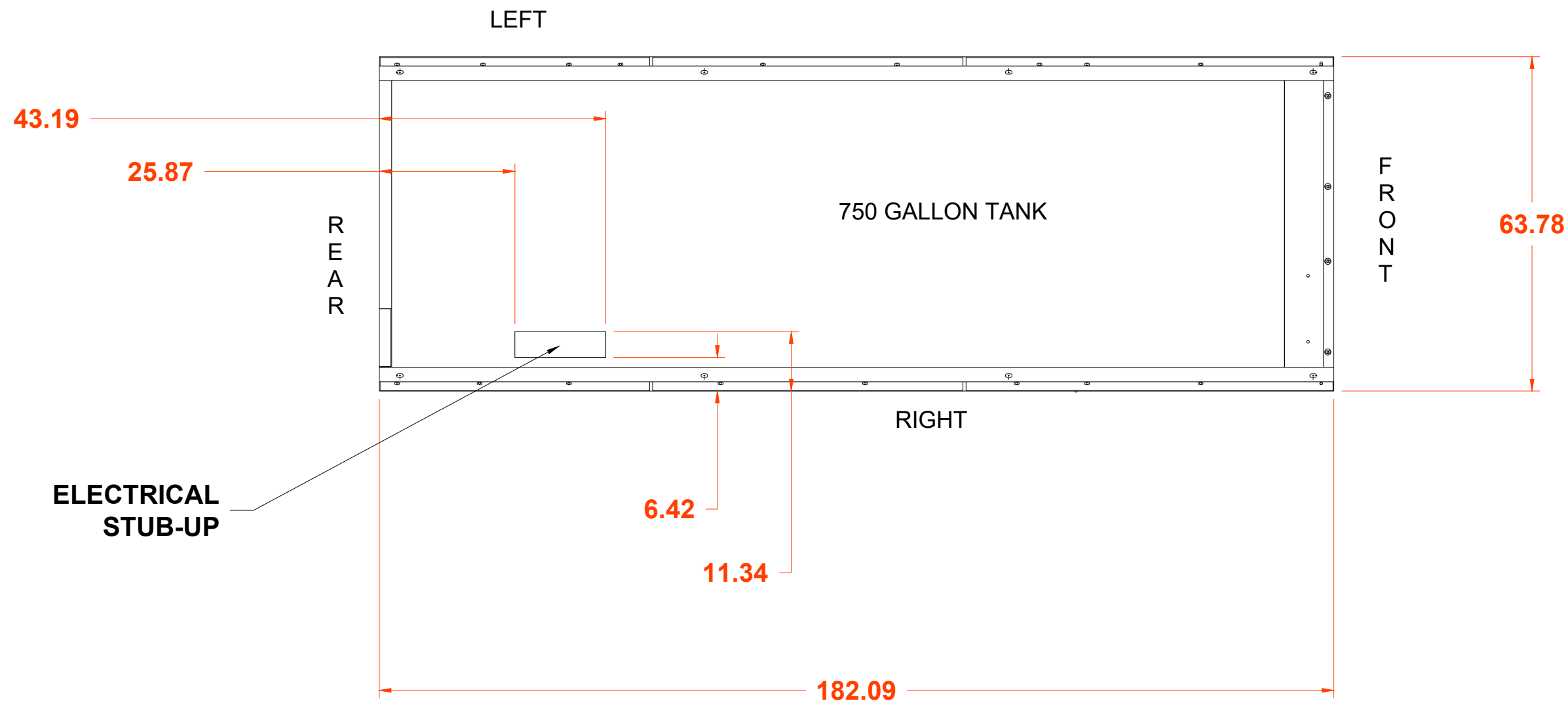

DATE	REVISION DESCRIPTION	NO.

MIDWEST ENGINES AND GENERATORS
C13GC-400kw / SA ENC / INTEGRAL TANK

Thompson
Energy Solutions



1245 Bridgestone Blvd - LaVergne, TN 37086

DRAWN BY: JODI SWANNER	DATE: 5/13/2026	SCALE: 1/2" = 1'-0"	PO / SUBMITTAL ID: TES-001267	CAT DRAWING SET NO. LS3870	ASSET ID: 86489
1 of 3					

DOOR SWING VIEW

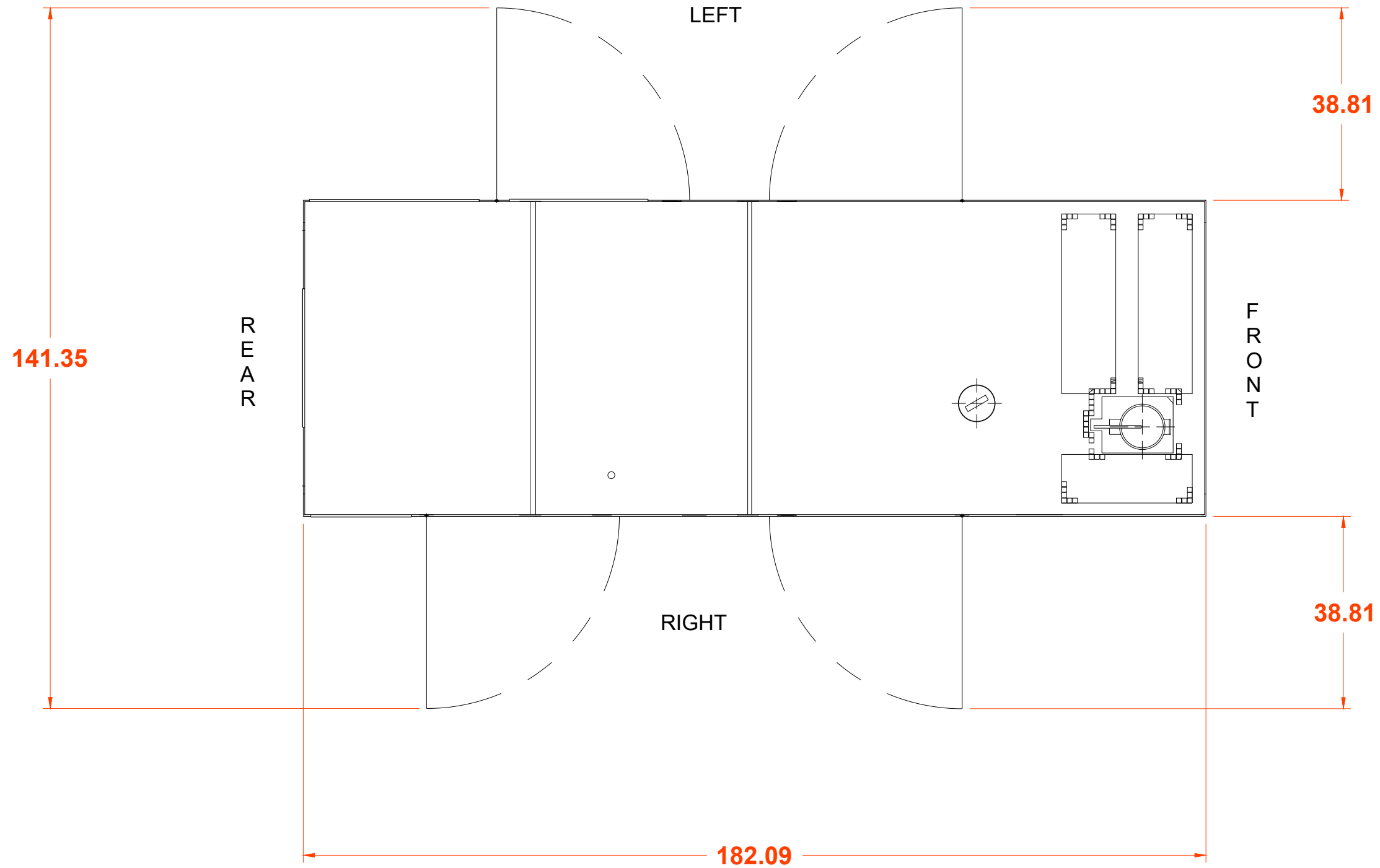

DATE	REVISION DESCRIPTION	NO.

MIDWEST ENGINES AND GENERATORS
 C13GC-400kw / SA ENC / INTEGRAL TANK

Thompson
 Energy Solutions



1245 Bridgestone Blvd - LaVergne, TN 37086

DRAWN BY: JODI SWANNER	DATE: 5/13/2026	SCALE: 1/2" = 1'-0"	PO / SUBMITTAL ID: TES-001267	CAT DRAWING SET NO. LS3870	ASSET ID: 86489
2 of 3					

EMERGENCY STOP BUTTON

DOOR HANDLE

RIGHT VIEW

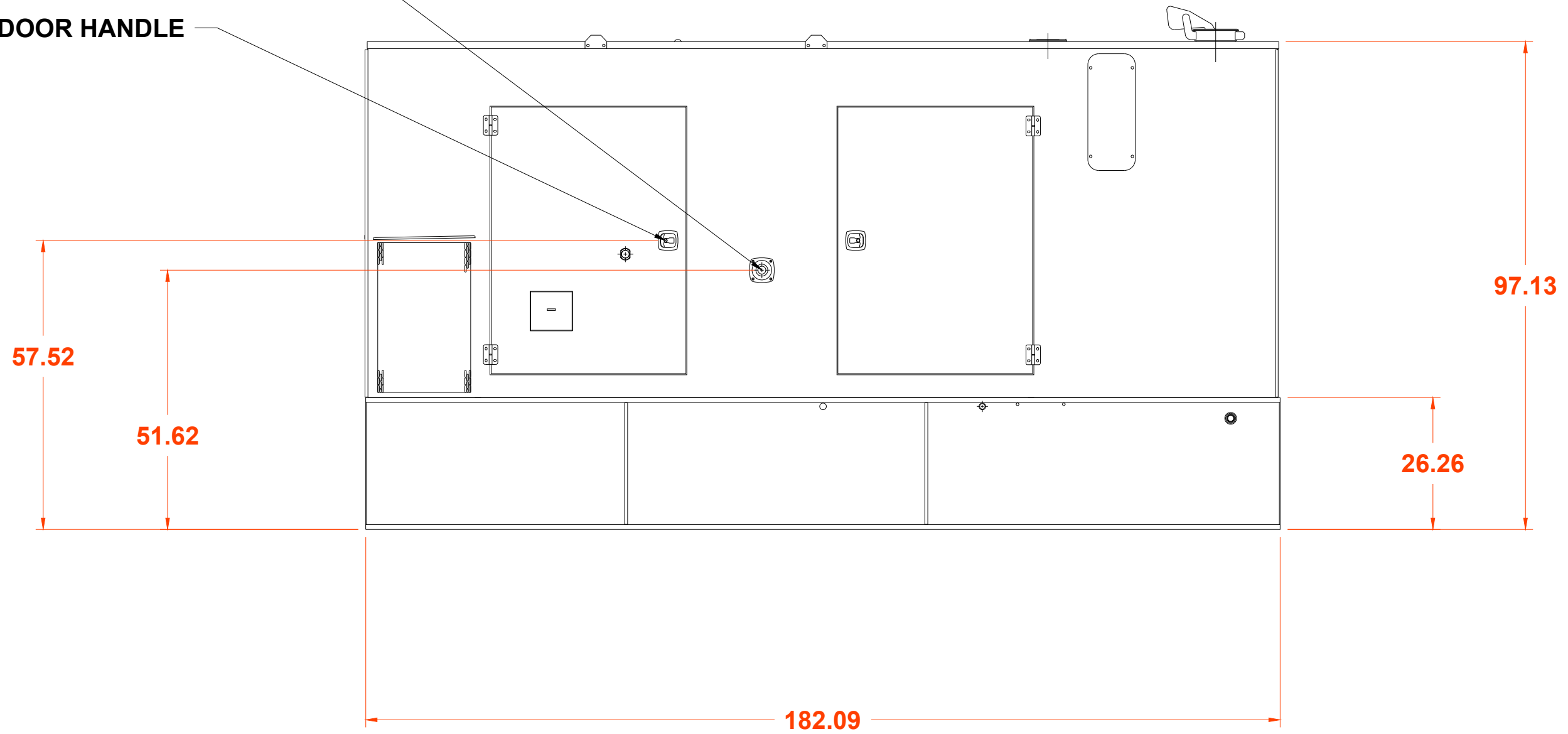

DATE	REVISION DESCRIPTION	NO.

MIDWEST ENGINES AND GENERATORS

C13GC-400kw / SA ENC / INTEGRAL TANK



1245 Bridgestone Blvd - LaVergne, TN 37086

DRAWN BY: JODI SWANNER	DATE: 5/13/2026	SCALE: 1/2" = 1'-0"	PO / SUBMITTAL ID: TES-001267	CAT DRAWING SET NO. LS3870	ASSET ID: 86489
3 of 3					

WIRE PULL for: Midwest Engines and Generators

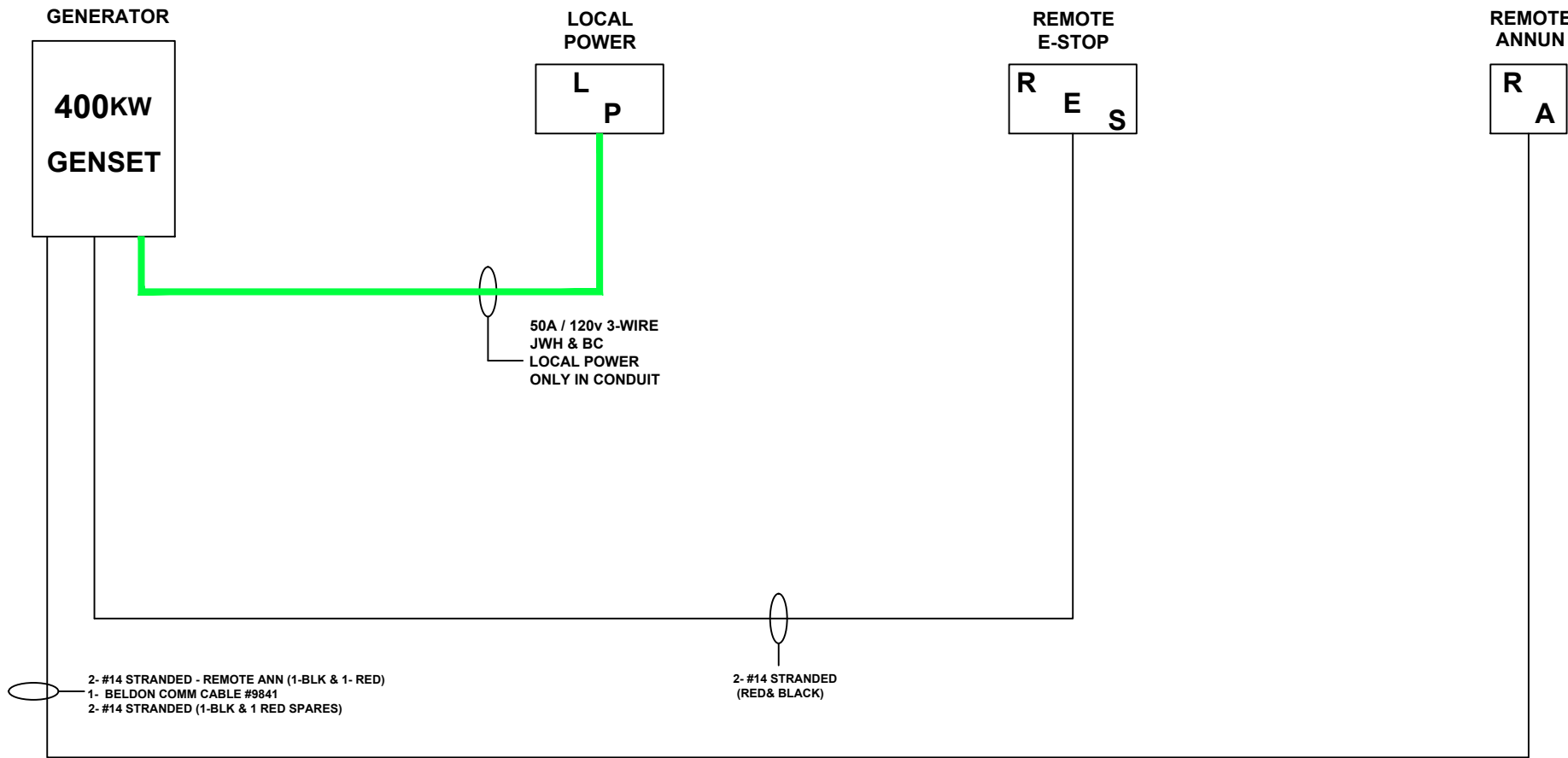

DATE	REVISION DESCRIPTION	NO.

MIDWEST ENGINES AND GENERATORS

400KW - E-STOP - REMOTE ANNUNCIATOR

Thompson Energy Solutions

1245 Bridgestone Blvd - LaVergne, TN 37086

DRAWN BY: JODI SWANNER	DATE: 5/12/2026	SCALE: DO NOT SCALE	PO / SUBMITTAL ID: TES-001267	CAT DRAWING SET NO.	ASSET ID: 86489
----------------------------------	---------------------------	-------------------------------	---	----------------------------	---------------------------

CAT Schematics

CONTROL SCHEMATIC (GCCP 1.2)

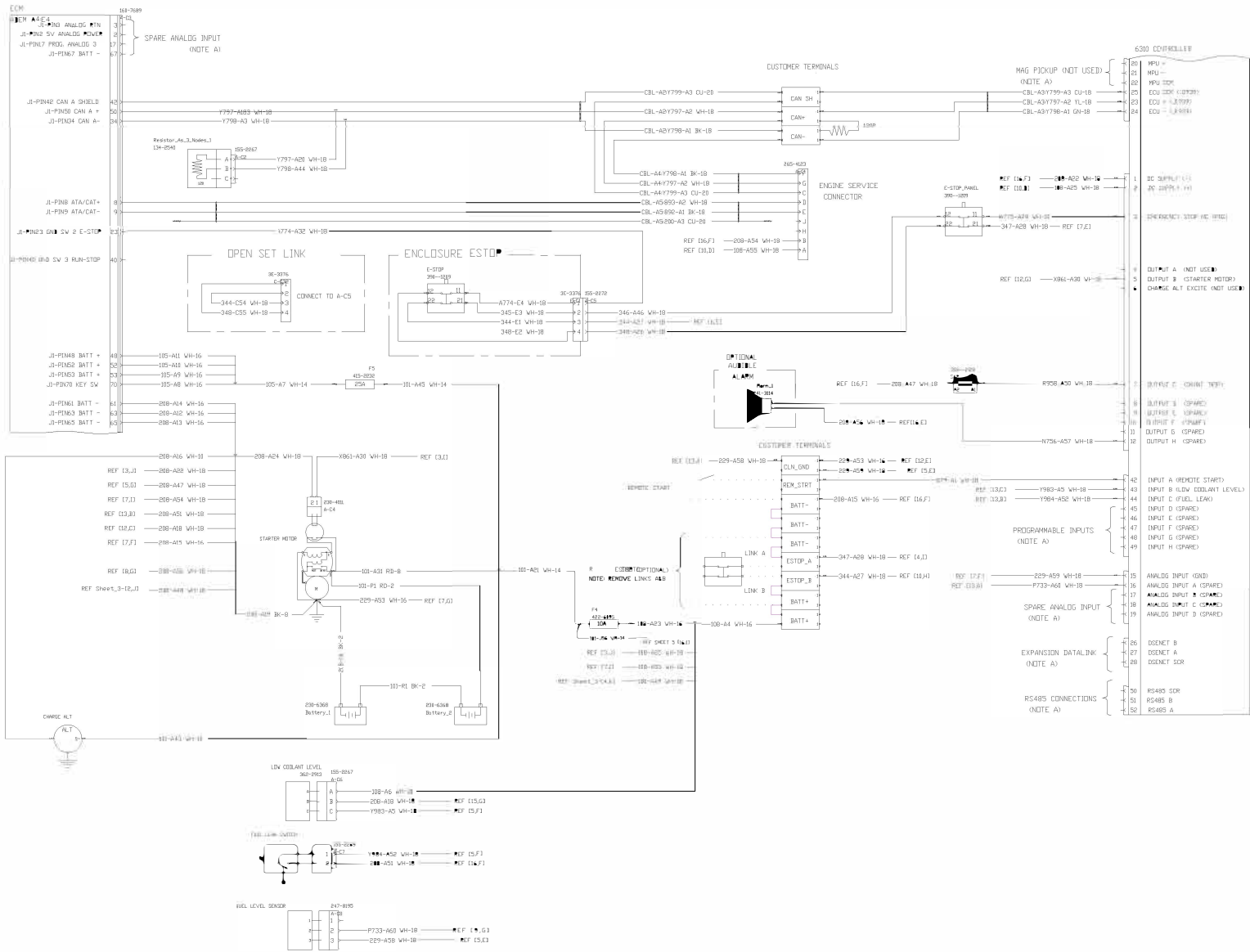

CAT Schematics

ADDITIONAL OPTIONS

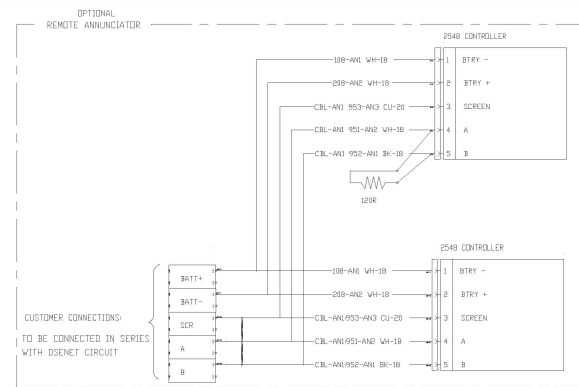
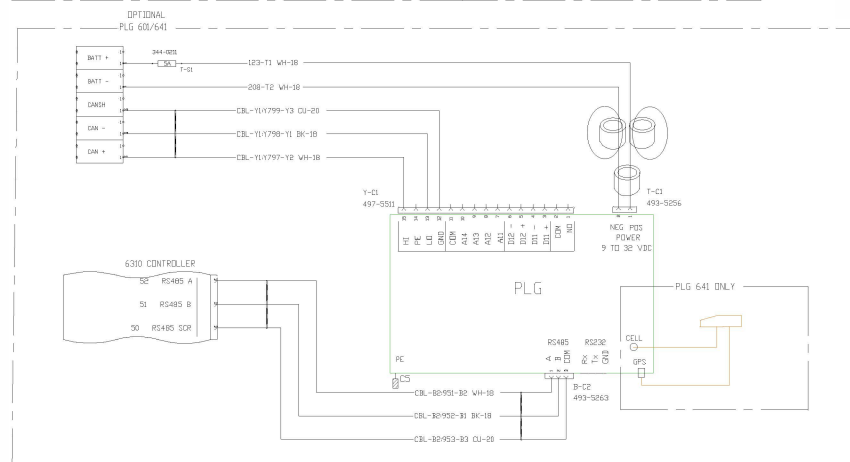
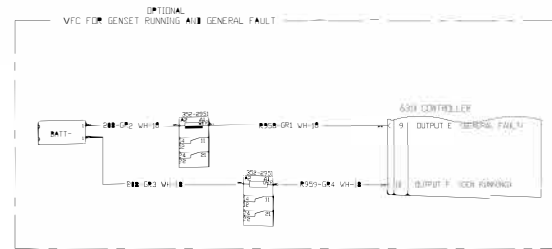
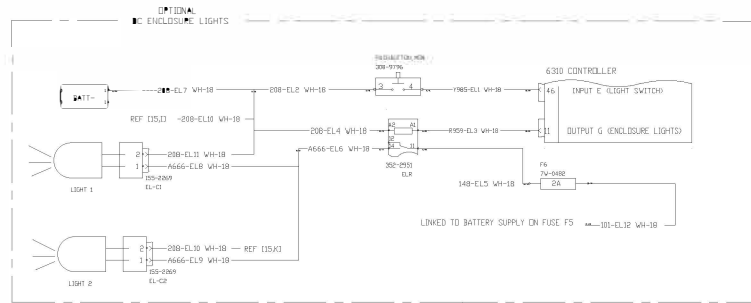

1	1	1	1
2	2	2	2
3	3	3	3
4	4	4	4
5	5	5	5
6	6	6	6
7	7	7	7
8	8	8	8
9	9	9	9
10	10	10	10
11	11	11	11
12	12	12	12
13	13	13	13
14	14	14	14
15	15	15	15
16	16	16	16
17	17	17	17
18	18	18	18
19	19	19	19
20	20	20	20
21	21	21	21
22	22	22	22
23	23	23	23
24	24	24	24
25	25	25	25
26	26	26	26
27	27	27	27
28	28	28	28
29	29	29	29
30	30	30	30
31	31	31	31
32	32	32	32
33	33	33	33
34	34	34	34
35	35	35	35
36	36	36	36
37	37	37	37
38	38	38	38
39	39	39	39
40	40	40	40
41	41	41	41
42	42	42	42
43	43	43	43
44	44	44	44
45	45	45	45
46	46	46	46
47	47	47	47
48	48	48	48
49	49	49	49
50	50	50	50
51	51	51	51
52	52	52	52
53	53	53	53
54	54	54	54
55	55	55	55
56	56	56	56
57	57	57	57
58	58	58	58
59	59	59	59
60	60	60	60
61	61	61	61
62	62	62	62
63	63	63	63
64	64	64	64
65	65	65	65
66	66	66	66
67	67	67	67
68	68	68	68
69	69	69	69
70	70	70	70
71	71	71	71
72	72	72	72
73	73	73	73
74	74	74	74
75	75	75	75
76	76	76	76
77	77	77	77
78	78	78	78
79	79	79	79
80	80	80	80
81	81	81	81
82	82	82	82
83	83	83	83
84	84	84	84
85	85	85	85
86	86	86	86
87	87	87	87
88	88	88	88
89	89	89	89
90	90	90	90
91	91	91	91
92	92	92	92
93	93	93	93
94	94	94	94
95	95	95	95
96	96	96	96
97	97	97	97
98	98	98	98
99	99	99	99
100	100	100	100

CAT Schematics

ADDITIONAL OPTIONS

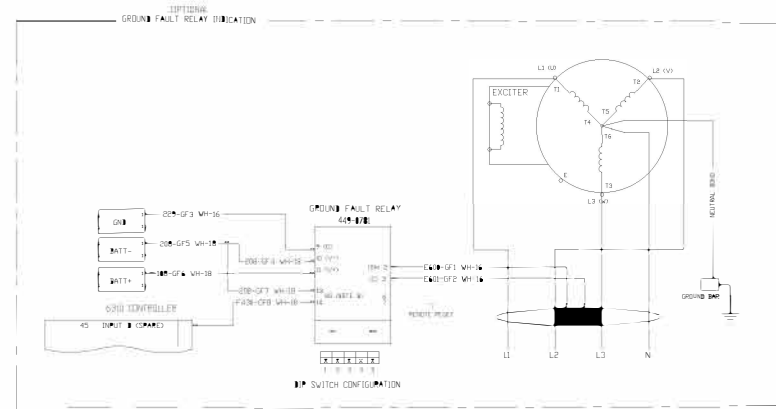
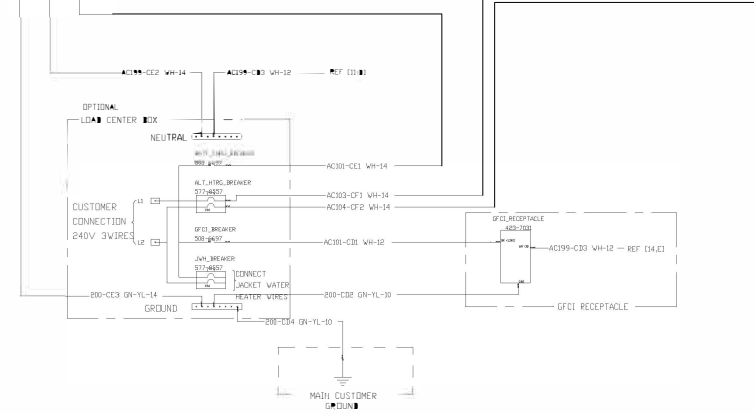
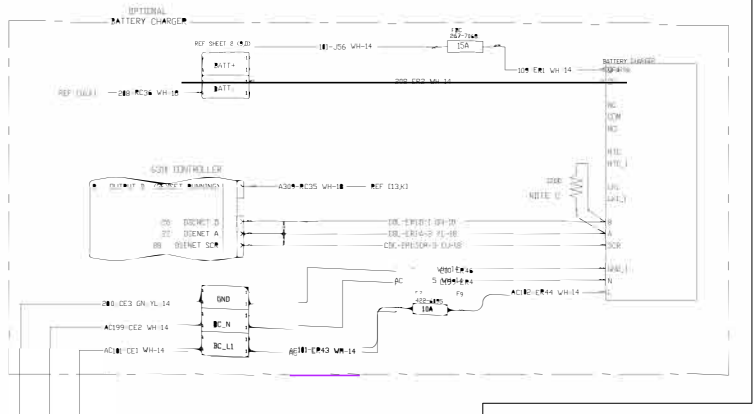
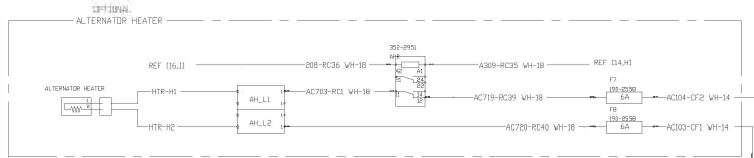

NO.	DESCRIPTION	DATE
1	ISSUED FOR WORK	
2	REVISIONS	
3	REVISIONS	
4	REVISIONS	
5	REVISIONS	
6	REVISIONS	
7	REVISIONS	
8	REVISIONS	
9	REVISIONS	
10	REVISIONS	
11	REVISIONS	
12	REVISIONS	
13	REVISIONS	
14	REVISIONS	
15	REVISIONS	
16	REVISIONS	
17	REVISIONS	
18	REVISIONS	
19	REVISIONS	
20	REVISIONS	
21	REVISIONS	
22	REVISIONS	
23	REVISIONS	
24	REVISIONS	
25	REVISIONS	
26	REVISIONS	
27	REVISIONS	
28	REVISIONS	
29	REVISIONS	
30	REVISIONS	
31	REVISIONS	
32	REVISIONS	
33	REVISIONS	
34	REVISIONS	
35	REVISIONS	
36	REVISIONS	
37	REVISIONS	
38	REVISIONS	
39	REVISIONS	
40	REVISIONS	
41	REVISIONS	
42	REVISIONS	
43	REVISIONS	
44	REVISIONS	
45	REVISIONS	
46	REVISIONS	
47	REVISIONS	
48	REVISIONS	
49	REVISIONS	
50	REVISIONS	

Concrete Pad Recommendation

Midwest Engines and Generators C13GC-400kw with a 674 Usable Gallons Diesel Tank

Gen-Set Footprint	Width (ft.)	CAT Recommended Border in Feet		Gen-Set Weight	Encl & tank Weight	Tank Cap. Gallons	Fuel Weight	Total Weight	Pad Thickness (ft.)	Pad Thickness (inches)
		Side	End							
15.25	5.5	1	1	9,055	10,580	745	5289.5	24,925	1.28	15

Results shown here

Overall Recommended Pad Dimensions

Length	Width
17.25	7.5

***Width above does not include door swings.**

Add 39 inches to LEFT side for this.

Add 39 inches to RIGHT side for this.

NOTE:
 Thompson Power is not trained in the correct application of steel reinforcement of concrete slabs.
 These are recommendations only.
 Proper design should be submitted and approved by the proper engineering authorities.



COVERAGE WITHOUT INTERRUPTION

Extended Service Coverage (ESC)

GENERATOR SETS & ELECTRIC POWER SYSTEMS

Your operation depends on reliable power. That's why you trust Cat® electric power systems. With Cat Financial Insurance Services, you get service coverage that's just as durable and long-lasting—so you can spend less time managing your equipment and more time running your business. ESC for prime and standby generator sets, switchgear, automatic transfer switches (ATS), uninterruptible power supplies (UPS) and engine paralleling and integration controls (EPIC) is built to protect your investment and your peace of mind.

BUILT FOR IT.™





A VARIETY OF COVERAGE OPTIONS

- > **New ESC:** coverage for new generator sets, switchgear, ATS, UPS and EPIC
- > **Advantage ESC:** coverage for used generator sets, switchgear, ATS, UPS and EPIC
- > **Overhaul Protection for Commercial (OPC) ESC:** coverage for overhauled generator sets

ESC BENEFITS

- > Protect your investment with coverage for parts and labor expense on covered components (less any applicable deductible)
- > Avoid unexpected repair costs caused by unscheduled repairs
- > Budget for unexpected repairs and lock in costs up front
- > Make sure repairs are done right the first time with factory-trained technicians using genuine Cat parts
- > Return your electric power systems to their original operating specifications, meeting all requirements for safe use and environmental compliance
- > Combine ESC with a Customer Support Agreement for complete maintenance and repair protection

WHY ESC?

- > **GLOBAL COVERAGE:** Our ESC is available wherever you are, for all your ESC coverage and service needs. It's true global service with no zones or territory restrictions.
- > **LOCAL EXPERTISE:** Trained technicians at more than 2,500 Caterpillar authorized service locations have the experience, training and tools to repair your engine quickly and accurately.
- > **EASE OF DOING BUSINESS:** Our pricing terms are simple, and you can customize coverage options to fit your individual needs.
- > **PEACE OF MIND:** When you choose ESC, you can be confident knowing your investment is protected by the power of Caterpillar.
- > **HISTORY OF PROTECTION:** Your Cat dealer is backed by Cat Financial—together, we've been providing product support with ESC programs to electric power customers since 1986.

For more details, contact your local Cat dealer about ESC today.

This is a brief description of ESC. It is subject to change without notice. In case of conflict, the ESC contract will govern.

PEHJ0378 ©2014 Caterpillar | All Rights Reserved

CAT, CATERPILLAR, BUILT FOR IT, their respective logos, "Caterpillar Yellow" and the "Power Edge" trade dress, as well as corporate and product identity used herein, are trademarks of Caterpillar and may not be used without permission.



WE'VE GOT YOU COVERED

**CAT[®] EXTENDED
SERVICE COVERAGE
For Cat Generator Sets**





EXTENDED SERVICE COVERAGE

For Cat® Generator Sets

Your operation depends on reliable power. Having a sound repair strategy is important to ensuring reliable power. How will you deal with unexpected downtime? And how will you manage your costs when repairs are necessary?

Manage Your Budget with Cat Extended Service Coverage

- Avoid unexpected costs for unscheduled repairs
- Minimize downtime with repairs completed by trained technicians using genuine Cat parts
- Program options to meet your business needs

...and stay productive

Extended Service Coverage helps you manage to the bottom line. To fix your cost of operation consider total maintenance and repair coverage, combine Extended Service Coverage with a Cat dealer maintenance plan.

With a Cat technician on the job you are assured that your generator set will be returned to its original operating specification, meeting all requirements for safe use and environmental compliance.

Whether your generator set is new, used or overhauled each Extended Service Coverage plan is designed to meet your specific needs.

POWER YOU CAN COUNT ON

Coverage throughout the life of your generator set

**New
Extended Service
Coverage***

**Advantage
Extended Service
Coverage****

**Overhaul
Protection
Coverage**

*Available only if purchased before end of original factory warranty.

**Available after the end of the original factory warranty and before the first overhaul.

Cat® Extended Service Coverage (ESC)

4 EASY STEPS TO PROTECT YOUR STANDBY GENERATOR SET

Your operation depends on reliable power. That's why you trust Cat® generator sets. With Extended Service Coverage (ESC), you get service coverage that's just as durable and long-lasting. ESC for **new, used and overhauled standby generator sets** protects your investment and your peace of mind. Choosing coverage is as easy as following these four steps.

1 CHOOSE FROM A VARIETY OF COVERAGE OPTIONS

First, extend your protection beyond the original factory warranty by choosing the coverage option that's right for your situation.

NEW ESC	Coverage for electric power standby generator sets is available in 36- to 120- month terms, in 12-month increments, if purchased before the end of your original factory warranty.
ADVANTAGE ESC	Your engine or genset is eligible if it meets all of the following criteria: <ul style="list-style-type: none">> Within defined age and usage hour limitations> Not previously overhauled> Passes Advantage inspection requirements administered by a Cat authorized dealer (if applicable by program).
OVERHAUL ESC	Coverage is available in 12- to 60- month terms, in 12-month increments. Your standby generator set is eligible once a qualifying overhaul has been completed by an authorized Cat dealer in accordance with the Overhaul ESC Checklist.

2 IDENTIFY YOUR COVERAGE NEEDS

Next, identify the age and current operating hours of your generator set since delivery or overhaul. Then calculate your annual hours of use to choose the best ESC coverage terms to fit your needs.

BUILT FOR IT.



3 SELECT YOUR COVERAGE LEVEL

Then, choose from our Silver, **Gold**, Platinum or Platinum Plus coverage levels (New and Advantage ESC only) to get the exact amount of protection you need based on the Coverage Matrix¹ and Additional Allowances. Overhaul ESC options are also available. Contact your local Cat dealer for details.

COVERAGE MATRIX¹

Cooling System	Silver	Gold	Platinum ²
Thermostat Housing	✓	✓	✓
Water Manifold Housing	✓	✓	✓
Jacket Water Precooler	✓	✓	✓
Jacket Water Pump		✓	✓
Thermostat			✓
Radiator & Fan			✓
Fuel System			
Steel Fuel Lines	✓	✓	✓
Fuel Shutoff Solenoid	✓	✓	✓
Fuel Injectors		✓	✓
Fuel Transfer Pump & Housing			✓
Fuel Priming Pump			✓
Fuel Transfer Pump			✓
Lubrication System			
Pan, Pump Cooler	✓	✓	✓
Crankcase Breather			✓
Engine Oil Pump Drive			✓
Prelubrication Pump			✓
Electric System			
Control Module (ECM)	✓	✓	✓
Sensors: All Engine Sensors	✓	✓	✓
Wiring Harness & Connectors			✓
Starter			✓
Engine Alternator			✓
Alternator End			
Alternator, including Rotor, Stator and Exciter	✓	✓	✓
Generator Controls		✓	✓
Power Center		✓	✓

Air Induction & Exhaust	Silver	Gold	Platinum ²
Exhaust Manifolds, Studs & Gaskets	✓	✓	✓
Inlet Air Heater Relay	✓	✓	✓
Intake Manifold	✓	✓	✓
Turbocharger(s)		✓	✓
Air-to-Air Aftercooler Cores			✓
Muffler/Exhaust System			✓
Exhaust Guards			✓
Diesel Oxidation Catalyst			✓
Short Block			
Cylinder Block Casting	✓	✓	✓
Crankshaft	✓	✓	✓
Connecting Rod Assembly	✓	✓	✓
Piston, Wrist Pin, Retainer Clip & Piston Rings	✓	✓	✓
Idler and Timing Gears			✓
Accessory Drive			✓
Cylinder Head			
Cylinder Head	✓	✓	✓
Intake & Exhaust Valves	✓	✓	✓
Valve Mechanism	✓	✓	✓
Camshaft, Camshaft Bearings, Key, Gear	✓	✓	✓
Front & Rear Covers			
Front Cover/Plate/Housing/Gears & Gaskets	✓	✓	✓
Vibration Damper	✓	✓	✓
Flywheel Housing & Gasket	✓	✓	✓
Crankshaft Front & Rear Seal			✓
Optional Aftertreatment Coverage			
Diesel Particulate Filter	✓ ³	✓ ³	✓ ³
Selective Catalytic Reduction	✓ ³	✓ ³	✓ ³

¹ This Coverage Matrix is for reference only and does not represent a complete list of covered components. For additional information, please reference the appropriate ESC contract.

² Platinum level coverage covers all as-shipped consist from the factory with Cat part numbers. Some exclusions may apply.

³ Recent emissions-compliant engines or generator sets may be equipped with a Diesel Particulate Filter (DPF) and/or a Selective Catalytic Reduction (SCR). We offer coverage at an additional costs on these emissions components. Silver, Gold, Platinum or Platinum Plus base level coverage is required.

ADDITIONAL ALLOWANCES

Engine Displacement ⁴	Travel/Mileage Limitations		Emergency Freight	Rental ⁵		Crane & Rigging ⁶	Overtime
	Silver, Gold, Platinum	Platinum Plus Only	All Coverage Levels	Platinum Only	Platinum Plus Only	Platinum Plus Only	Platinum Plus Only
Up to 4 liters	2 hr/100 mi	10 hr/500 mi	\$500 USD	\$2,500 USD	\$5,000 USD	\$1,000 USD	\$1,500 USD
Over 4 liters up to 7.5 liters	4 hr/200 mi	10 hr/500 mi	\$500 USD	\$5,000 USD	\$10,000 USD	\$1,000 USD	\$1,500 USD
Over 7.5 liters up to 34 liters	8 hr/320 mi	10 hr/500 mi	\$500 USD	\$10,000 USD	\$20,000 USD	\$5,000 USD	\$1,500 USD
Over 34 liters	8 hr/320 mi	10 hr/500 mi	\$500 USD	\$15,000 USD	\$40,000 USD	\$12,500 USD	\$1,500 USD

⁴ Please refer to the generator set spec sheets for particular engine displacement.

⁵ Allowance is granted if covered failure repairs cannot be completed within 96 hours (for Platinum) or 48 hours (for Platinum Plus) of the authorized dealer technician's initial visit.

⁶ Allowance is granted if covered failure repairs cannot be completed within 48 hours of the authorized dealer technician's initial visit.

Platinum Plus goes beyond Platinum coverage to include Cat components installed by an authorized dealer. Such components must be approved. See your Cat dealer for details.

4 PURCHASE AND REGISTER YOUR ESC

Finally, work with your local Cat dealer to complete the process—and get the protection and peace of mind you deserve.

This marketing tool does not represent a contract or obligation of any kind between Cat Financial Insurance Services, its parent or affiliates, and the equipment owner. For details on any dealer agreement, including a complete description of the terms, conditions, and/or exclusions, contact your local Cat dealer. All graphics and lists in this marketing tool are provided solely for general information purposes and are not intended to be a solicitation or an offer to sell any product or service.

PEHJ0380-01 ©2018 Caterpillar | All Rights Reserved

CAT, CATERPILLAR, BUILT FOR IT, their respective logos, "Caterpillar Yellow," and the "Power Edge" trade dress, as well as corporate and product identity used herein, are trademarks of Caterpillar and may not be used without permission.



FTSR.AU3508 - Engine Generators

UL Product

Engine Generators

CATERPILLAR INC

560 REHOBOTH RD
GRIFFIN, GA 30224-7618 United States

AU3508

Model(s): C175-20

Stationary engine generator assemblies, Model(s): 3500 Global Series, 3508, 3508B, 3512, 3512B, 3512B HD, 3512C, 3516, 3516B, 3516B HD, 3516C, 3516C-HD, 3516E, C15, C175-16, C18, C9, GS277, GS471, GS471 LS, GS533, GS534, GS603

Stationary engine generator assemblies, 3 phase, Model(s): C13 (350-400kW), C15 (350-550kW), C18 (500 kW, Aftertreatment), C18 (500-750 kW), D125, D150, D175, D200, G3412 (500KW standby), G3500 (750-1500kW standby), G3520 (2000-2600KW standby)

Stationary engine generator assemblies, 3 phase, Model(s): C13GC - D350GC & D400GC (350-400 kW Standby)

Stationary engine generator assemblies, 3 phase, Model(s): C15GC - D450GC & D500GC (450-500 kW Standby)

Stationary engine generator assemblies, 3 phase, Model(s): C18GC - D550GC & D600GC (550-600 kW Standby)

Stationary engine generator assemblies, 3 phase, Model(s): C9GC - D250GC & D300GC (250-300 kW Standby)

Stationary engine generator assemblies, 3 phase, Model(s): DG, followed by 30, 40, 50, 60, 80, 100, 125 or 150, may be followed by -2 or -4.

Stationary engine generator assemblies, 3 phase and single phase, Model(s): D100, D100GC, D125GC, D150GC, D175GC, D200GC, D40GC, D50GC, D60GC, D80, D80GC

Stationary engine generator assemblies, 3 phase and single phase, Model(s): D, followed by 40, 50 or 60, maybe followed by -, maybe followed by a number designated x, maybe followed by letter designated XX.

Stationary engine generator assemblies, 3 phase and single phase, "Verizon Series", Model(s): D40, D50

Stationary engine generator assemblies, single phase, Model(s): D100GC, D40GC, D50GC, D60GC, D80GC

Stationary engine generator assemblies, single phase, Model(s): DG, followed by 30, 40, 50, 60, 80 or 100, may be followed by -2 or -4.

* - With an optional one or two letter prefix.

The appearance of a company's name or product in this database does not in itself assure that products so identified have been manufactured under UL's Follow-Up Service. Only those products bearing the UL Mark should be considered to be Certified and covered under UL's Follow-Up Service. Always look for the Mark on the product.

UL permits the reproduction of the material contained in the Online Certification Directory subject to the following conditions: 1. The Guide Information, Assemblies, Constructions, Designs, Systems, and/or Certifications (files) must be presented in their entirety and in a non-misleading manner, without any manipulation of the data (or drawings). 2. The statement "Reprinted from the Online Certifications Directory with permission from UL" must appear adjacent to the extracted material. In addition, the reprinted material must include a copyright notice in the following format: "© 2021 UL LLC"



VMC GROUP
THE POWER OF TOGETHER™



CERTIFICATE OF COMPLIANCE
SEISMI DESIGN OF NONSTRUCTURAL COMPONENTS AND SYSTEMS



Certification No.

IBC

VMA-53383-01C (Revision 3)

Expiration Date: 7/31/2026

Certification Parameters:

The nonstructural products (mechanical and/or electrical components) listed on this certificate are CERTIFIED¹ FOR SEISMIC APPLICATIONS in accordance with the following building code² releases.

IBC 2021, 2018, 2015, 2012

The following model designations, options, and accessories are included in this certification. Reference report number VMA-53383-01 as issued by The VMC Group for a complete list of certified models, included accessories/options, and certified installation methods.

Caterpillar; Diesel Gensets
i6 GC Models; 250 kW - 600 kW

The above referenced equipment is APPROVED for seismic application when properly installed³, used as intended, and contains a Seismic Certification Label referencing this Certificate of Compliance⁴. As limited by the tabulated values, below grade, grade, and roof-level installations, installations in essential facilities, for life safety applications, and/or of equipment containing hazardous contents are permitted and included in this certification with an Equipment Importance Factor assigned as $I_p=1.5$. The equipment is qualified by successful seismic shake table testing at the nationally recognized University of California Berkeley Pacific Earthquake Engineering Research Center under the witness of the ISO Accredited Product Certification Agency, the VMC Group.

Certified Seismic Design Levels			
Certified IBC	Importance $I_p \leq 1.5$ Soil Classes A-E Risk Categories I-IV Design Categories A-F	$z/h \leq 1.0$	$z/h = 0.0$
		$S_{DS} \leq 0.567 g$	$S_{DS} \leq 1.700 g$

Certified Seismic Installation Methods
Rigid Mounting From Unit Base To Rigid Structure

HEADQUARTERS
113 Main Street
Bloomingdale, NJ 07403
Phone: 973.838.1780
Toll Free: 800.569.8423
Fax: 973.492.8430

CALIFORNIA
180 Promenade Circle
Suite 300
Sacramento, CA 95834
Phone: 916.634.7771

TEXAS
11930 Brittmoore Park Drive
Houston, TX 77041
Phone: 713.466.0003
Fax: 713.466.1355

thevmcgroup.com





CERTIFICATE OF COMPLIANCE
SEISMIC DESIGN OF NONSTRUCTURAL COMPONENTS AND SYSTEMS

ertified Product Table:

Model	Max Rating [kW]	On/Off Tank	Length [in.]	Width [in.]	Height [in.]	Max Weight [lbs]
D250GC	250	Off Tank	156	57	78	6,299
D300GC	300				64	5,750
D350GC	350		88	64	88	8,781
D400GC	400					8,856
D450GC	450					9,718
D500GC	500		196	73	86	9,826
D550GC	550					10,481
D600GC	600	On tank	181	57	93	10,664
D250GC	250					12,040
D300GC	300		207	64	101	12,234
D350GC	350					15,854
D400GC	400		15,929			
D450GC	450		234	102	18,774	
D500GC	500				17,950	
D550GC	550		196	73	99	19,850
D600GC	600					22,077

Group	Type	S _{DS} (z/h=0)	S _{DS} (z/h=1)	A _{Flex-H}	A _{Rig-H}	A _{Flex-V}	A _{Rig-V}	F _p /W _p
Seismic	AC156	1.70	0.57	1.70	0.68	1.13	0.45	0.77

This certification includes the diesel generator set and included factory supplied options. This certification only covers accessories and options directly mounted to the genset. The genset and applicable options shall be installed per the manufacturer supplied seismic installation instructions. For a list of certified configurations and options please directly contact the manufacturer. This certification excludes all non-factory supplied accessories and options, including but not limited to isolation/restraint devices, other electrical/mechanical components and all connections for electrical, fuel, heating or cooling fluid, or other pipe/conduit connections and configurations not detailed in the above charts. Flexibility in the connections must be maintained as to not transmit load into the equipment. Design specials are outside the scope of this certification.



VMA-53383-01C (Revision 3)
Issue Date: Wednesday, July 22, 2020
Revision Date: Monday, November 25, 2024
Expiration Date: Friday, July 31, 2026



VMC GROUP
THE POWER OF TOGETHER™

CATERPILLAR®

CERTIFICATE OF COMPLIANCE

SEISMIC DESIGN OF NONSTRUCTURAL COMPONENTS AND SYSTEMS

Notes & Comments:

1. All equipment listed herein successfully passed the seismic acceptance criteria for shake testing non-structural components and systems as set forth in the ICC AC-156. The Test Response Spectrum (TRS) enveloped the Required Response Spectrum (RRS) for all units tested. The tested units were representative sample(s) of a contingent of models and all remained captive and structurally sound after the seismic shake simulation. The units also remained functionally operational after the simulation testing as functional testing was completed by the equipment manufacturer before and after the seismic simulations. Although a seismic qualified unit inherently contains some wind resisting capacity, that capacity is undetermined and is excluded from this certification. Snow/Ice loads have been neglected and thus limit the unit to be installed both indoors (covered by an independent protective structure) and out of doors (exposed to accumulating snow/ice) for ground snow loads no greater than 30 psf for all applications.
2. The following building codes are addressed under this certification:
 - IBC 2021 referencing ASCE7-16 and ICC-ES AC-156
 - IBC 2018 referencing ASCE7-16 and ICC-ES AC-156
 - IBC 2015 referencing ASCE7-10 and ICC-ES AC-156
 - IBC 2012 referencing ASCE7-10 and ICC-ES AC-156
3. Refer to the manufacturer supplied installation drawings for anchor requirements and mounting considerations for seismic applications. Required anchor locations, size, style, and load capacities (tension and shear) may be specified on the installation drawings or specified by a 3rd party. Mounting requirement details such as anchor brand, type, embedment depth, edge spacing, anchor-to-anchor spacing, concrete strength, special inspection, wall design, and attachment to non-building structures must be outlined and approved by the Engineer of Record for the project or building. Structural walls, structural floors, and housekeeping pads must also be seismically designed and approved by the project or building Structural Engineer of Record to withstand the seismic anchor loads as defined on the installation drawings. The installing contractor is responsible for ensuring the proper installation of all anchors and mounting hardware.
4. For this certificate and certification to remain valid, this certificate must correspond to the "Seismic Certification Label" found affixed to the unit by the factory. The label ensures the manufacturer built the unit in conformance to the IBC seismic design criteria set forth by the Certified Seismic Qualification Agency, the VMC Group, and meets the seismic design levels claimed by this certificate.
5. Mechanical, Electrical, and Plumbing connections to the equipment must be flexibly attached as to not transfer load through the connection. The structural integrity of any conduit, cable trays, piping, ductwork and/or flexible connections is the responsibility of others. This certification makes no statements of compliance in regards to NEMA, IP, UL, CSA, or other relevant standards after a seismic event. For compliance to other relevant standards, please contact the manufacturer.
6. This certificate applies to units manufactured at:
 - 1720 West Kingsbury Street, Seguin, TX 78155
 - Rodo via Luiz de Queiroz-KM 157 CEP 13420-900, Piracicaba/SP-Brazil
7. This certification follows the VMC Group's ISO-17065 Scheme.

John P. Giuliano, PE
President, VMC Group



VMA-53383-01C (Revision 3)
Issue Date: Wednesday, July 22, 2020
Revision Date: Monday, November 25, 2024
Expiration Date: Friday, July 31, 2026



Effective with sales to the first user on or after August 1, 2014

CATERPILLAR LIMITED WARRANTY

Industrial, Petroleum, Locomotive, and Agriculture Engine Products and Electric Power Generation Products

Worldwide

Caterpillar Inc. or any of its subsidiaries ("Caterpillar") warrants new and remanufactured engines and electric power generation products sold by it (including any products of other manufacturers packaged and sold by Caterpillar), to be free from defects in material and workmanship.

This warranty does not apply engines sold for use in on-highway vehicle or marine applications; engines in machines manufactured by or for Caterpillar; C175, 3500 and 3600 series engines used in locomotive applications; 3000 Family engines, C0.5 through C4.4 and ACERT™ (C6.6, C7, C7.1, C9, C9.3, C11, C13, C15, C18, C27, and C32) engines used in industrial, mobile agriculture and locomotive applications; or Cat® batteries. These products are covered by other Caterpillar warranties.

This warranty is subject to the following:

Warranty Period

- For industrial engines, engines in a petroleum applications or Petroleum Power Systems (excluding petroleum fire pump application), or engines in a Locomotive application, or Uninterruptible Power Supply (UPS) systems, the warranty period is 12 months after date of delivery to the first user.
- For engines used in petroleum fire pump and mobile agriculture applications the warranty period is 24 months after date of delivery to the first user.
- For controls only (EPIC), configurable and custom switchgear products, and automatic transfer switch products, the warranty period is 24 months after date of delivery to the first user.
- For new CG132, CG170 and CG260 series power generation products the warranty period is 24 months/16,000 hours, whichever comes first, after date of delivery to first user.
- For electric power generation products other than CG132, CG170 and CG260 series in prime or continuous applications the warranty period is 12 months. **For standby applications the warranty period is 24 months/1000 hours.** For emergency standby applications the warranty period is 24 months/400 hours. All terms begin after date of delivery to the first user.
- For all other applications the warranty period is 12 months after date of delivery to the first user.

Caterpillar Responsibilities

If a defect in material or workmanship is found during the warranty period, Caterpillar will, during normal working hours and at a place of business of a Cat dealer or other source approved by Caterpillar:

- Provide (at Caterpillar's choice) new, Remanufactured, or Caterpillar approved repaired parts or assembled components needed to correct the defect.
- **Note:** New, remanufactured, or Caterpillar approved repaired parts or assembled components provided under the terms of this warranty are warranted for the remainder of the warranty period applicable to the product in which installed as if such parts were original components of that product. Items replaced under this warranty become the property of Caterpillar.
- Replace lubricating oil, filters, coolant, and other service items made unusable by the defect.
- Provide reasonable and customary labor needed to correct the defect, including labor to disconnect the product from and reconnect the product to its attached equipment, mounting, and support systems, if required.

For new 3114, 3116, and 3126 engines and electric power generation products (including any new products of other manufacturers packaged and sold by Caterpillar):

- Provide travel labor, up to four hours round trip, if in the opinion of Caterpillar, the product cannot reasonably be transported to a place of business of a Cat dealer or other source approved by Caterpillar (travel labor in excess of four hours round trip, and any meals, mileage, lodging, etc. is the user's responsibility).

For all other products:

- Provide reasonable travel expenses for authorized mechanics, including meals, mileage, and lodging, when Caterpillar chooses to make the repair on-site.

User Responsibilities

The user is responsible for:

- Providing proof of the delivery date to the first user.
- Labor costs, except as stated under "Caterpillar Responsibilities," including costs beyond those required to disconnect the product from and reconnect the product to its attached equipment, mounting, and support systems.

- Travel or transporting costs, except as stated under "Caterpillar Responsibilities."
- Premium or overtime labor costs.
- Parts shipping charges in excess of those that are usual and customary.
- Local taxes, if applicable.
- Costs to investigate complaints, unless the problem is caused by a defect in Caterpillar material or workmanship.
- Giving timely notice of a warrantable failure and promptly making the product available for repair.
- Performance of the required maintenance (including use of proper fuel, oil, lubricants, and coolant) and items replaced due to normal wear and tear.
- Allowing Caterpillar access to all electronically stored data.

Limitations

Caterpillar is not responsible for:

- Failures resulting from any use or installation that Caterpillar judges improper.
- Failures resulting from attachments, accessory items, and parts not sold or approved by Caterpillar.
- Failures resulting from abuse, neglect, and/or improper repair.
- Failures resulting from user's delay in making the product available after being notified of a potential product problem.
- Failures resulting from unauthorized repairs or adjustments, and unauthorized fuel setting changes.
- Damage to parts, fixtures, housings, attachments, and accessory items that are not part of the engine, Cat Selective Catalytic Reduction System or electric power generation product (including any products of other manufacturers packaged and sold by Caterpillar).
- Repair of components sold by Caterpillar that is warranted directly to the user by their respective manufacturer. Depending on type of application, certain exclusions may apply. Consult your Cat dealer for more information.

(Continued on reverse side...)

This warranty covers every major component of the products. Claims under this warranty should be submitted to a place of business of a Cat dealer or other source approved by Caterpillar. For further information concerning either the location to submit claims or Caterpillar as the issuer of this warranty, write Caterpillar Inc., 100 N. E. Adams St., Peoria, IL USA 61629.

Caterpillar's obligations under this Limited Warranty are subject to, and shall not apply in contravention of, the laws, rules, regulations, directives, ordinances, orders, or statutes of the United States, or of any other applicable jurisdiction, without recourse or liability with respect to Caterpillar.

A) For products operating outside of Australia, Fiji, Nauru, New Caledonia, New Zealand, Papua New Guinea, the Solomon Islands and Tahiti, the following is applicable:

NEITHER THE FOREGOING EXPRESS WARRANTY NOR ANY OTHER WARRANTY BY CATERPILLAR, EXPRESS OR IMPLIED, IS APPLICABLE TO ANY ITEM CATERPILLAR SELLS THAT IS WARRANTED DIRECTLY TO THE USER BY ITS MANUFACTURER.

THIS WARRANTY IS EXPRESSLY IN LIEU OF ANY OTHER WARRANTIES, EXPRESS OR IMPLIED, INCLUDING ANY WARRANTY OF MERCHANTABILITY OR FITNESS FOR A PARTICULAR PURPOSE, EXCEPT CATERPILLAR EMISSION-RELATED COMPONENTS WARRANTIES FOR NEW ENGINES, WHERE APPLICABLE. REMEDIES UNDER THIS WARRANTY ARE LIMITED TO THE PROVISION OF MATERIAL AND SERVICES, AS SPECIFIED HEREIN.

CATERPILLAR IS NOT RESPONSIBLE FOR INCIDENTAL OR CONSEQUENTIAL DAMAGES.

CATERPILLAR EXCLUDES ALL LIABILITY FOR OR ARISING FROM ANY NEGLIGENCE ON ITS PART OR ON THE PART OF ANY OF ITS EMPLOYEES, AGENTS OR REPRESENTATIVES IN RESPECT OF THE MANUFACTURE OR SUPPLY OF GOODS OR THE PROVISION OF SERVICES RELATING TO THE GOODS.

IF OTHERWISE APPLICABLE, THE VIENNA CONVENTION ON CONTRACTS FOR THE INTERNATIONAL SALE OF GOODS IS EXCLUDED IN ITS ENTIRETY.

For personal or family use engines or electric power generation products, operating in the USA, its territories and possessions, some states do not allow limitations on how long an implied warranty may last nor allow the exclusion or limitation of incidental or consequential damages. Therefore, the previously expressed exclusion may not apply to you. This warranty gives you specific legal rights and you may also have other rights, which vary by jurisdiction. To find the location of the nearest Cat dealer or other authorized repair facility, call (800) 447-4986. If you have questions concerning this warranty or its applications, call or write:

In USA and Canada: Caterpillar Inc., Engine Division, P. O. Box 610, Mossville, IL 61552-0610, Attention: Customer Service Manager, Telephone (800) 447-4986. Outside the USA and Canada: Contact your Cat dealer.

B) For products operating in Australia, Fiji, Nauru, New Caledonia, New Zealand, Papua New Guinea, the Solomon Islands and Tahiti, the following is applicable:

THIS WARRANTY IS IN ADDITION TO WARRANTIES AND CONDITIONS IMPLIED BY STATUTE AND OTHER STATUTORY RIGHTS AND OBLIGATIONS THAT BY ANY APPLICABLE LAW CANNOT BE EXCLUDED, RESTRICTED OR MODIFIED ("MANDATORY RIGHTS"). ALL OTHER WARRANTIES OR CONDITIONS, EXPRESS OR IMPLIED (BY STATUTE OR OTHERWISE), ARE EXCLUDED. WITHOUT LIMITING THE FOREGOING PROVISIONS OF THIS PARAGRAPH, WHERE A PRODUCT IS SUPPLIED FOR BUSINESS PURPOSES, THE CONSUMER GUARANTEES UNDER THE CONSUMER GUARANTEES ACT 1993 (NZ) WILL NOT APPLY.

NEITHER THIS WARRANTY NOR ANY OTHER CONDITION OR WARRANTY BY CATERPILLAR, EXPRESS OR IMPLIED (SUBJECT ONLY TO THE MANDATORY RIGHTS), IS APPLICABLE TO ANY ITEM CATERPILLAR SELLS THAT IS WARRANTED DIRECTLY TO THE USER BY ITS MANUFACTURER.

IF THE MANDATORY RIGHTS MAKE CATERPILLAR LIABLE IN CONNECTION WITH SERVICES OR GOODS, THEN TO THE EXTENT PERMITTED UNDER THE MANDATORY RIGHTS, THAT LIABILITY SHALL BE LIMITED AT CATERPILLAR'S OPTION TO (a) IN THE CASE OF SERVICES, THE SUPPLY OF THE SERVICES AGAIN OR THE PAYMENT OF THE COST OF HAVING THE SERVICES SUPPLIED AGAIN AND (b) IN THE CASE OF GOODS, THE REPAIR OR REPLACEMENT OF THE GOODS, THE SUPPLY OF EQUIVALENT GOODS, THE PAYMENT OF THE COST OF SUCH REPAIR OR REPLACEMENT OR THE ACQUISITION OF EQUIVALENT GOODS.

CATERPILLAR EXCLUDES ALL LIABILITY FOR OR ARISING FROM ANY NEGLIGENCE ON ITS PART OR ON THE PART OF ANY OF ITS EMPLOYEES, AGENTS OR REPRESENTATIVES IN RESPECT OF THE MANUFACTURE OR SUPPLY OF GOODS OR THE PROVISION OF SERVICES RELATING TO THE GOODS.

CATERPILLAR IS NOT LIABLE FOR INCIDENTAL OR CONSEQUENTIAL DAMAGES UNLESS IMPOSED UNDER MANDATORY RIGHTS.

IF OTHERWISE APPLICABLE, THE VIENNA CONVENTION ON CONTRACTS FOR THE INTERNATIONAL SALE OF GOODS IS EXCLUDED IN ITS ENTIRETY.

C) For products supplied in Australia:

IF THE PRODUCTS TO WHICH THIS WARRANTY APPLIES ARE:

- I. PRODUCTS OF A KIND ORDINARILY ACQUIRED FOR PERSONAL, DOMESTIC OR HOUSEHOLD USE OR CONSUMPTION; OR
- II. PRODUCTS THAT COST AUD 40,000 OR LESS,

WHERE THOSE PRODUCTS WERE NOT ACQUIRED FOR THE PURPOSE OF RE-SUPPLY OR FOR THE PURPOSE OF USING THEM UP OR TRANSFORMING THEM IN THE COURSE OF PRODUCTION OR MANUFACTURE OR IN THE COURSE OF REPAIRING OTHER GOODS OR FIXTURES, THEN THIS SECTION C APPLIES.

THE FOLLOWING MANDATORY TEXT IS INCLUDED PURSUANT TO THE AUSTRALIAN CONSUMER LAW AND INCLUDES REFERENCES TO RIGHTS THE USER MAY HAVE AGAINST THE DIRECT SUPPLIER OF THE PRODUCTS: OUR GOODS COME WITH GUARANTEES THAT CANNOT BE EXCLUDED UNDER THE AUSTRALIAN CONSUMER LAW. YOU ARE ENTITLED TO A REPLACEMENT OR REFUND FOR A MAJOR FAILURE AND COMPENSATION FOR ANY OTHER REASONABLY FORESEEABLE LOSS OR DAMAGE. YOU ARE ALSO ENTITLED TO HAVE THE GOODS REPAIRED OR REPLACED IF THE GOODS FAIL TO BE OF ACCEPTABLE QUALITY AND THE FAILURE DOES NOT AMOUNT TO A MAJOR FAILURE. THE INCLUSION OF THIS TEXT DOES NOT CONSTITUTE ANY REPRESENTATION OR ACCEPTANCE BY CATERPILLAR OF LIABILITY TO THE USER OR ANY OTHER PERSON IN ADDITION TO THAT WHICH CATERPILLAR MAY HAVE UNDER THE AUSTRALIAN CONSUMER LAW.

TO THE EXTENT THE PRODUCTS FALL WITHIN THIS SECTION C BUT ARE NOT OF A KIND ORDINARILY ACQUIRED FOR PERSONAL, DOMESTIC OR HOUSEHOLD USE OR CONSUMPTION, CATERPILLAR LIMITS ITS LIABILITY TO THE EXTENT IT IS PERMITTED TO DO SO UNDER THE AUSTRALIAN CONSUMER LAW TO, AT ITS OPTION, THE REPAIR OR REPLACEMENT OF THE PRODUCTS, THE SUPPLY OF EQUIVALENT PRODUCTS, OR THE PAYMENT OF THE COST OF SUCH REPAIR OR REPLACEMENT OR THE ACQUISITION OF EQUIVALENT PRODUCTS.

THE WARRANTY SET OUT IN THIS DOCUMENT IS GIVEN BY CATERPILLAR INC. OR ANY OF ITS SUBSIDIARIES, 100 N. E. ADAMS ST, PEORIA, IL USA 61629, TELEPHONE 1 309 675 1000, THE USER IS RESPONSIBLE FOR ALL COSTS ASSOCIATED WITH MAKING A CLAIM UNDER THE WARRANTY SET OUT IN THIS DOCUMENT, EXCEPT AS EXPRESSLY STATED OTHERWISE IN THIS DOCUMENT, AND THE USER IS REFERRED TO THE BALANCE OF THE DOCUMENT TERMS CONCERNING CLAIM PROCEDURES, CATERPILLAR RESPONSIBILITIES AND USER RESPONSIBILITIES.

TO THE EXTENT PERMISSIBLE BY LAW, THE TERMS SET OUT IN THE REMAINDER OF THIS WARRANTY DOCUMENT (INCLUDING SECTION B) CONTINUE TO APPLY TO PRODUCTS TO WHICH THIS SECTION C APPLIES.

©2014 Caterpillar All Rights Reserved.

CAT, CATERPILLAR, their respective logos, "Caterpillar Yellow" the "Power Edge" trade dress as well as corporate and product identity used herein, are trademarks of Caterpillar and may not be used without permission.