



RECORD ONLY SUBMITTAL PACKAGE

Prepared For:

Central States Diesel Generators
1901 South Prairie
Waukesha, Wisconsin 53189

THIS SUBMITTAL IS BEING PREPARED FOR RECORD PURPOSES ONLY

The information presented in this submittal package has been approved

and is provided for record purposes only.

Date: 12/3/2025



Serving Cummins Customers
cummins.com/sales-and-service



DISCLAIMER



Serving Cummins Customers

Cummins power solutions are supported by the largest and best-trained worldwide certified sales/distributor network in the industry. This network will help you select and install the critical power solution to meet the requirements of your specific application. This same network provides experts with advanced technology to make your life easier while providing a seamless support experience.

IMPORTANT: *The critical power solution information and specifications included in this pdf can be used by the site contractor(s) and/or engineer(s) to assist with planning for and accomplishing the overall power solution installation. Please forward this document to the appropriate personnel, as necessary.*

It is the obligation of the electrical contractor and reviewing engineer to determine that the item quantities and accuracy of this submittal is correct as required for the job. Any inaccuracies or deviations must be addressed with Cummins Inc. before release to manufacturing. Any releases of material to manufacturing by the above parties constitute an acceptance of the accuracy of the submittal. Any changes after release will be viewed as a change order, subject to pricing changes. Please take the time to review this package for accuracy to prevent any after-shipment problems that could cause delay in energization.

Cummins certifies that these drawings, material lists, specification and datasheets have been checked prior to submittal and they:

- accurately depict the proposed equipment*
- provide current information to the date of the submittal and*
- present true and accurate equipment information.*

This Approval Drawing Package is submitted as our interpretation of the project requirements and/or the specifications for this job. Please note that issuance of these submittals shall not be deemed or interpreted as performance nor acceptance of your purchase order terms and conditions.

For questions or comments regarding this submittal, please contact the Cummins Project Manager listed on the title page.

TABLE OF CONTENTS



Section 1 - Project Information

Project Bill of Material

Section 2 - Generator Specification Sheets

Generator Specification Sheet

Generator Data Sheet

PowerCommand Control (PCC) Specification Sheet

Fuel Tank Specification Sheet

Exhaust Emission Compliance Statement

Exhaust Emission Data Sheet

Sound Data Sheet

Prototype Test Summary Report

Cooling System Data Sheet

Alternator Data Sheet

Section 3 - Generator Accessories

Battery Charger Specification Sheet

Circuit Breaker Data Sheet

Green Sound Level 2 Intake Baffle (Ship Loose)

Sound Level2 Baffle (A052M018)

Section 4 - Generator Drawings and Interconnects

Generator Outline Drawing

Generator Options Outline Drawing

Circuit Breaker Outline Drawing

Enclosure Outline Drawing

Fuel Tank Outline Drawing

Foundation Outline Drawing

AC Interconnection Wiring Diagram

Section 5 - Warranty

Generator Warranty Statement

SECTION 1

Project Information



Bill of Material

Feature Code	Description	Qty
C100D6C C100 D6C Install-US-Stat A331-2 L169-2 L090-2 L193-2 B184-2 R098-2 B946-2 F217-2 P176-2 F252-2 F179-2 C319-2 C127-2 C312-2 C318-2 H609-2 H700-2 H012-2 K796-2 H536-2 KV03-2 KX51-2 2800 3400 A366-2 A422-2 1900 D041-2 A333-2 BB89-2 E125-2 E089-2 H669-2 E153-2 H706-2 L028-2 L050-2 A322-2 F253-2 H268-2 L260-2 A052M018-FRD	C100D6C Diesel Genset, 60Hz, 100kW C100D6C, Diesel Genset, 60Hz, 100kW U.S. EPA, Stationary Emergency Application Duty Rating - Standby Power (ESP) Emission Certification, EPA, Tier 3, NSPS CI Stationary Emergency Listing - UL 2200 NFPA 110 Type 10 Level 1 Capable Exciter/Regulator - Permanent Magnet Generator, 3 Phase Sensor Voltage - 120/208, 3 Phase, Wye, 4 Wire Alternator - 60Hz, 12L, 208/120V, 120C, 40C Ambient Aluminum Sound Attenuated Level 2 Enclosure, with Exhaust System Enclosure Color - Green, Aluminum Enclosure - Wind Load 180 MPH, ASCE7-10 Skidbase - Housing Ready UL142 Sub Base Dual Wall Basic, Diesel Fuel Tank, 24 Hour Minimum Fuel Water Separator Mechanical Fuel Gauge Switch - Fuel Tank, Rupture Basin Control Mounting - Left Facing PowerCommand 1.1 Controller Gauge - Oil Pressure Stop Switch - Emergency Control Display Language - English Load Connection - Single Circuit Breaker, Location A, 125A - 400A, 3P, LSI, 600 Volts AC, 80%, UL Circuit Breaker or Terminal Box (Position B) - None Circuit Breaker or Terminal Box (Position C) - None Engine Governor - Electronic, Isochronous Engine Starter - 12 Volt DC Motor Engine Exhaust Connection - None Engine Air Cleaner - Normal Duty Battery Charging Alternator Battery Charger - 6 Amp, Regulated Engine Cooling - Radiator, High Ambient Air Temperature, Ship Fitted Extension - Coolant Drain Engine Coolant - 50% Antifreeze, 50% Water Mixture Coolant Heater, Cold Ambient Engine Oil Genset Warranty - 2 Years Base Literature - English Packing - Skid, Poly Bag Larger Battery Rack Extension - Oil Drain Green Sound Level 2 Intake Baffle - Ship Loose Sound Level2 Baffle, Shipped Loose	1



NOTES:

Proposal is for equipment only, offloading, rigging, and installation by others.

Fuel and permits, unless listed above, is not included.

Cummins Standard Start-up and testing is included. Additional tests, such as NETA testing, if required, is by others
Coordination Study not provided.

SECTION 2

Generator Specifications





Diesel Generator Set

QSB5 Series Engine

50-125 kW Standby

EPA Tier 3 Emissions



Description

Cummins® generator sets are fully integrated power generation systems providing optimum performance, reliability and versatility for stationary Standby applications.

Features

Heavy duty engine - Rugged 4-cycle industrial diesel delivers reliable power and fast response to load changes.

Alternator - Several alternator sizes offer selectable motor starting capability with low reactance 2/3 pitch windings, low waveform distortion with non-linear loads and fault clearing short-circuit capability.

Control system - The PowerCommand® 1.1 electronic control is standard equipment and provides total generator set system integration including automatic remote starting/stopping, precise frequency and voltage regulation, alarm and status message display, output metering, auto-shutdown at fault detection and NFPA 110 Level 1 compliance. The PowerCommand 2.3 control is also optional and is UL 508 Listed and provides AmpSentry™ protection.

Cooling system - Standard cooling package provides reliable running at up to 50 °C (122 °F) ambient temperature.

Enclosures - The aesthetically appealing enclosure incorporates special designs that deliver one of the quietest generators of its kind. Aluminium material plus durable powder coat paint provides the best anti-corrosion performance. The generator set enclosure has been evaluated to withstand 180 MPH wind loads in accordance with ASCE7 -10. The design has hinged doors to provide easy access for service and maintenance.

Fuel tanks - Dual wall sub-base fuel tanks are offered as optional features, providing economical and flexible solutions to meet extensive code requirements on diesel fuel tanks.

NFPA - The generator set accepts full rated load in a single step in accordance with NFPA 110 for Level 1 systems.

Warranty and service - Backed by a comprehensive warranty and worldwide distributor network.

Model	Standby 60 Hz		Prime 60 Hz		Data sheets
	kW	kVA	kW	kVA	
C50D6C	50	63	45	56	NAD-6333-EN
C60D6C	60	75	54	68	NAD-6334-EN
C80D6C	80	100	72	90	NAD-6335-EN
C100D6C	100	125	90	113	NAD-6336-EN
C125D6C	125	156	112.5	141	NAD-6216-EN

Generator Set Specifications

Governor regulation class	ISO8528 Part 1 Class G3
Voltage regulation, no load to full load	± 1.0%
Random voltage variation	± 1.0%
Frequency regulation	isochronous
Random frequency variation	± 0.50%
Radio frequency emissions compliance	FCC code title 47 part 15 class A and B

Engine Specifications

Design	Turbocharged and charge air cooled
Bore	107 mm (4.21 in.)
Stroke	124 mm (4.88 in.)
Displacement	4.5 L (272 in ³)
Cylinder block	Cast iron, in-line 4 cylinder
Battery capacity	850 amps per battery at ambient temperature of 0 °C (32 °F)
Battery charging alternator	100 amps
Starting voltage	2 x 12 volt in parallel, negative ground
Lube oil filter type(s)	Spin-on with relief valve
Standard cooling system	High ambient radiator
Rated speed	1800 rpm

Alternator Specifications

Design	Brushless, 4 pole, drip proof, revolving field
Stator	2/3 pitch
Rotor	Direct coupled, flexible disc
Insulation system	Class H per NEMA MG1-1.65
Standard temperature rise	120 °C (248 °F) Standby
Exciter type	Torque match (shunt) with PMG as option
Alternator cooling	Direct drive centrifugal blower
AC waveform Total Harmonic Distortion (THDV)	< 5% no load to full linear load, < 3% for any single harmonic
Telephone Influence Factor (TIF)	< 50 per NEMA MG1-22.43
Telephone Harmonic Factor (THF)	< 3%

Available Voltages

1-phase	3-phase				
• 120/240	• 120/208	• 120/240	• 277/480	• 347/600	• 127/220

Generator Set Options

Fuel system

- **Basic fuel tanks**
- Regional fuel tanks

Engine

- **Engine air cleaner – normal** or heavy duty
- Shut down – low oil pressure
- **Extension – oil drain**
- Engine oil heater

Alternator

- **120 °C temperature rise alternator**
- 105 °C temperature rise alternator
- **PMG excitation**
- Alternator heater, 120 V
- Reconnectable full 1 phase output alternator

Control

- AC output analog meters
- **Stop switch – emergency**
- Auxiliary output relays (2)
- Auxiliary configurable signal inputs (8) and relay outputs (8)

Electrical

- **One, two or three circuit breaker configurations**
- **80% rated circuit breakers**
- 80% or 100% rated LSI circuit breakers
- **Battery charger**

Enclosure

- **Sound Level 1 or Level 2 enclosure, sandstone or green color**
- Weather protective enclosure with muffler installed, green color
- Winter protective enclosure, green color

Cooling system

- Shutdown – low coolant level
- Warning – low coolant level
- **Extension – coolant drain**
- **Coolant heater options:**
 - <4 °C (40 °F) – cold weather
 - <-18 °C (0 °F) – extreme cold

Exhaust system

- Exhaust connector NPT
- Exhaust muffler mounted

Generator set application

- Base barrier – elevated genset
- Radiator outlet duct adapter

Warranty

- **Base warranty – 2 year/1000 hours, Standby**
- Base warranty – 1 year/unlimited hours, Prime
- 3 year Standby warranty options
- 5 year Standby warranty options

Generator Set Accessories

- **Coolant heater**
- Battery heater kit
- Engine oil heater
- Remote control displays
- Auxiliary output relays (2)
- Auxiliary configurable signal inputs (8) and relay outputs (8)
- Annunciator – RS485
- Audible alarm
- Remote monitoring device – PowerCommand 500/550
- **Battery charger** – stand-alone, 12 V
- **Circuit breakers**
- Enclosure Sound Level 1 to Sound Level 2 upgrade kit
- Base barrier – elevated generator set
- Mufflers – industrial, residential or critical
- **Alternator PMG excitation**
- Alternator heater

Control System PowerCommand 1.1



PowerCommand control is an integrated generator set control system providing voltage regulation, engine protection, operator interface and isochronous governing (optional). Major features include:

- Battery monitoring and testing features and smart starting control system.
- Standard PCCNet interface to devices such as remote annunciator for NFPA 110 applications.
- Control boards potted for environmental protection.
- Control suitable for operation in ambient temperatures from -40 °C to +70 °C (-40 °F to +158 °F) and altitudes to 5000 meters (13,000 feet).
- Prototype tested; UL, CSA, and CE compliant.
- InPower™ PC-based service tool available for detailed diagnostics.

Operator/display panel

- Manual off switch
- Alpha-numeric display with pushbutton access for viewing engine and alternator data and providing setup, controls and adjustments (English or international symbols)
- LED lamps indicating generator set running, not in auto, common warning, common shutdown, manual run mode and remote start
- Suitable for operation in ambient temperatures from -40 °C to +70 °C
- Bargraph display (optional)

AC protection

- Over current warning and shutdown
- Over and under voltage shutdown
- Over and under frequency shutdown
- Over excitation (loss of sensing) fault
- Field overload

Engine protection

- Overspeed shutdown
- Low oil pressure warning and shutdown
- High coolant temperature warning and shutdown
- Low coolant level warning or shutdown

- Low coolant temperature warning
- High, low and weak battery voltage warning
- Fail to start (over crank) shutdown
- Fail to crank shutdown
- Redundant start disconnect
- Cranking lockout
- Sensor failure indication
- Low fuel level warning or shutdown

Alternator data

- Line-to-Line and Line-to-neutral AC volts
- 3-phase AC current
- Frequency
- Total kVA

Engine data

- DC voltage
- Lube oil pressure
- Coolant temperature
- Engine speed

Other data

- Generator set model data
- Start attempts, starts, running hours
- Fault history
- RS485 Modbus® interface
- Data logging and fault simulation (requires InPower service tool)

Digital governing (optional)

- Integrated digital electronic isochronous governor
- Temperature dynamic governing

Digital voltage regulation

- Integrated digital electronic voltage regulator
- 2-phase Line-to-Line sensing
- Configurable torque matching

Control functions

- Time delay start and cooldown
- Cycle cranking
- PCCNet interface
- (2) Configurable inputs
- (2) Configurable outputs
- Remote emergency stop
- Automatic Transfer Switch (ATS) control
- Generator set exercise, field adjustable

Options

- Auxiliary output relays (2)
- Remote annunciator with (3) configurable inputs and (4) configurable outputs
- **PMG alternator excitation**
- PowerCommand 500/550 for remote monitoring and alarm notification (accessory)
- Auxiliary, configurable signal inputs (8) and configurable relay outputs (8)
- AC output analog meters (bargraph)
 - Color-coded graphical display of:
 - 3-phase AC voltage
 - 3-phase current
 - Frequency
 - kVa
- Remote operator panel
- PowerCommand 2.3 control with AmpSentry protection

Ratings Definitions

Emergency Standby Power (ESP):

Applicable for supplying power to varying electrical load for the duration of power interruption of a reliable utility source. Emergency Standby Power (ESP) is in accordance with ISO 8528. Fuel Stop power in accordance with ISO 3046, AS 2789, DIN 6271 and BS 5514.

Limited-Time Running Power (LTP):

Applicable for supplying power to a constant electrical load for limited hours. Limited Time Running Power (LTP) is in accordance with ISO 8528.

Prime Power (PRP):

Applicable for supplying power to varying electrical load for unlimited hours. Prime Power (PRP) is in accordance with ISO 8528. Ten percent overload capability is available in accordance with ISO 3046, AS 2789, DIN 6271 and BS 5514.

Base Load (Continuous) Power (COP):

Applicable for supplying power continuously to a constant electrical load for unlimited hours. Continuous Power (COP) in accordance with ISO 8528, ISO 3046, AS 2789, DIN 6271 and BS 5514.

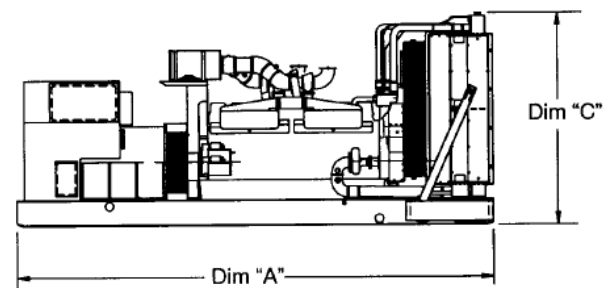
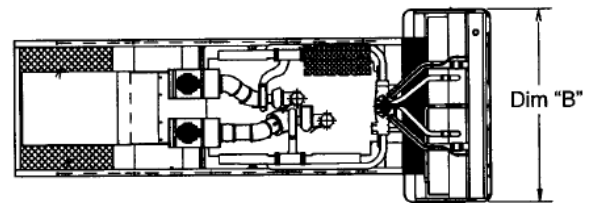

This outline drawing is for reference only. See respective model data sheet for specific model outline drawing number.

Do not use for installation design





Model	Dim "A" mm (in.)	Dim "B" mm (in.)	Dim "C" mm (in.)	Set weight* kg (lbs.)
Open set				
C50D6C	2482 (98)	1016 (40)	1321 (52)	958 (2113)
C60D6C	2482 (98)	1016 (40)	1321 (52)	1006 (2217)
C80D6C	2482 (98)	1016 (40)	1321 (52)	1054 (2324)
C100D6C	2482 (98)	1016 (40)	1321 (52)	1106 (2439)
C125D6C	2482 (98)	1016 (40)	1321 (52)	1173 (2586)
Weather protective enclosure				
C50D6C	2482 (98)	1016 (40)	1473 (58)	1039 (2290)
C60D6C	2482 (98)	1016 (40)	1473 (58)	1087 (2396)
C80D6C	2482 (98)	1016 (40)	1473 (58)	1135 (2503)
C100D6C	2482 (98)	1016 (40)	1473 (58)	1187 (2618)
C125D6C	2482 (98)	1016 (40)	1473 (58)	1254 (2765)
Sound attenuated enclosure Level 1				
C50D6C	3016 (119)	1016 (40)	1473 (58)	1221 (2693)
C60D6C	3016 (119)	1016 (40)	1473 (58)	1137 (2507)
C80D6C	3016 (119)	1016 (40)	1473 (58)	1185 (2614)
C100D6C	3016 (119)	1016 (40)	1473 (58)	1237 (2729)
C125D6C	3016 (119)	1016 (40)	1473 (58)	1304 (2876)
Sound attenuated enclosure Level 2				
C50D6C	3456 (136)	1016 (40)	1473 (58)	1228 (2708)
C60D6C	3456 (136)	1016 (40)	1473 (58)	1144 (2522)
C80D6C	3456 (136)	1016 (40)	1473 (58)	1192 (2629)
C100D6C	3456 (136)	1016 (40)	1473 (58)	1244 (2744)
C125D6C	3456 (136)	1016 (40)	1473 (58)	1311 (2891)
Winter protective enclosure				
C50D6C	3701 (146)	1016 (40)	1473 (58)	1254 (2758)
C60D6C	3701 (146)	1016 (40)	1473 (58)	1169 (2572)
C80D6C	3701 (146)	1016 (40)	1473 (58)	1218 (2679)
C100D6C	3701 (146)	1016 (40)	1473 (58)	1270 (2794)
C125D6C	3701 (146)	1016 (40)	1473 (58)	1337 (2941)

Refer to drawings for specific weights and dimensions

* Weights above are average. Actual weight varies with product configuration.

Codes and Standards

Codes or standards compliance may not be available with all model configurations – consult factory for availability.

	<p>This generator set is designed in facilities certified to ISO 9001 and manufactured in facilities certified to ISO 9001 or ISO 9002.</p>		<p>The generator set is available Listed to UL 2200, Stationary Engine Generator Assemblies.</p>
	<p>The Prototype Test Support (PTS) program verifies the performance integrity of the generator set design. Cummins products bearing the PTS symbol meet the prototype test requirements of NFPA 110 for Level 1 systems.</p>	<p>U.S. EPA</p>	<p>Engine certified to U.S. EPA SI Stationary Emission Regulation 40 CFR, Part 60.</p>
	<p>All low voltage models are CSA certified to product class 4215-01.</p>	<p>International Building Code</p>	<p>The generator set is certified to International Building Code (IBC) 2012.</p>

Warning: Back feed to a utility system can cause electrocution and/or property damage. Do not connect to any building's electrical system except through an approved device or after building main switch is open.

For more information contact your local Cummins distributor or visit power.cummins.com

Our energy working for you.™





Generator set data sheet

Model: **C100D6C**
 Frequency: 60 Hz
 Fuel type: **Diesel**
 KW rating: **100 standby**
 90 prime
 Emissions level: EPA Tier 3, Stationary emergency

Exhaust emission data sheet:	EDS-2029
Exhaust emission compliance sheet:	EPA-3042
Sound performance data sheet:	MSP-1303
Cooling performance data sheet:	MCP-1403
Prototype test summary data sheet:	PTS-450

Fuel consumption	Standby				Prime			
	kW (kVA)				kW (kVA)			
Ratings	100 (125)				90 (113)			
Load	1/4	1/2	3/4	Full	1/4	1/2	3/4	Full
US gph	2.80	4.80	6.90	8.90	2.40	4.30	6.40	7.70
L/hr	10.60	18.17	26.12	33.69	9.08	16.28	24.23	29.15

Engine	Standby rating	Prime rating
Engine manufacturer	Cummins Inc.	
Engine model	QSB5-G13	
Configuration	Cast iron, in-line, 4 cylinder	
Aspiration	Turbocharged and charge air cooled	
Gross engine power output, kWm (bhp)	129 (173)	113 (152)
BMEP at set rated load, kPa (psi)	1965 (285)	1696 (246)
Bore, mm (in)	107 (4.21)	
Stroke, mm (in)	124 (4.88)	
Rated speed, rpm	1800	
Piston speed, m/s (ft/min)	7.44 (1464)	
Compression ratio	17.3:1	
Lube oil capacity, L (qt)	12.2 (12.9)	
Overspeed limit, rpm	2250	

Fuel flow	
Maximum fuel flow, L/hr (US gph)	133 (35.0)
Maximum fuel inlet restriction with clean filter, mm Hg (in Hg)	127 (5.0)

Air	Standby rating	Prime rating
Combustion air, m ³ /min (scfm)	9.995 (353)	10.11 (357)
Maximum air cleaner restriction with clean filter, kPa (in H ₂ O)	1.25 (5)	

Exhaust

Exhaust flow at set rated load, m ³ /min (cfm)	24.9 (878)	22.4 (790)
Exhaust temperature, °C (°F)	489 (913)	431 (808)
Maximum back pressure, kPa (in H ₂ O)	10 (40.18)	10 (40.18)
Available exhaust back pressure with CPG sound level 2 enclosure muffler, kPa (in H ₂ O)	0 (0)	1.0 (4)
Available exhaust back pressure with CPG weather enclosure muffler, kPa (in H ₂ O)	1.0 (4)	2.0 (8)

Standard set-mounted radiator cooling

Ambient design, °C (°F)	50 (122)	
Fan load, kW _m (HP)	5.22 (7)	
Coolant capacity (with radiator), L (US Gal)	16 (4.2)	
Cooling system air flow, m ³ /min (scfm)	218.04 (7700)	
Total heat rejection, MJ/min (Btu/min)	12.22 (11584)	11.33 (10736)
Maximum cooling air flow static restriction, kPa (in H ₂ O)	0.12 (0.5)	

Weight²

Unit wet weight kgs (lbs)

Refer to drawings for specific weights and dimensions

Notes:

¹ For non-standard remote installations contact your local Cummins Power Generation representative.

² Weights represent a set with standard features. See outline drawing for weights of other configurations.

Derating factors

Standby	Engine power available to 1295 m (4250 ft) and ambient temperatures up to 40° C (104° F). Above these conditions, derate at 17.5% per 300 m (1000 ft) until 1700 m (5600 ft) and then derate at 2.2% per 300 m (1000 ft). Also derate 16.1% per 10° C (18° F)
Prime	Engine power available to 1448 m (4750 ft) and ambient temperatures up to 40° C (104° F). Above these conditions, derate at 17.5% per 300 m (1000 ft) until 1700 m (5600 ft) and then derate at 2.3% per 300 m (1000 ft). Also derate 18.8% per 10° C (18° F)

Ratings definitions

Emergency standby power (ESP):	Limited-time running power (LTP):	Prime power (PRP):	Base load (continuous) power (COP):
Applicable for supplying power to varying electrical load for the duration of power interruption of a reliable utility source. Emergency Standby Power (ESP) is in accordance with ISO 8528. Fuel Stop power in accordance with ISO 3046, AS 2789, DIN 6271 and BS 5514.	Applicable for supplying power to a constant electrical load for limited hours. Limited Time Running Power (LTP) is in accordance with ISO 8528.	Applicable for supplying power to varying electrical load for unlimited hours. Prime Power (PRP) is in accordance with ISO 8528. Ten percent overload capability is available in accordance with ISO 3046, AS 2789, DIN 6271 and BS 5514.	Applicable for supplying power continuously to a constant electrical load for unlimited hours. Continuous Power (COP) is in accordance with ISO 8528, ISO 3046, AS 2789, DIN 6271 and BS 5514.

Alternator data

Standard Alternators	Single phase ²		Three phase ¹			
Maximum temperature rise above 40 °C ambient	120 °C	120 °C	120 °C	120 °C	120 °C	120 °C
Feature code	BB88-2 ³	BB90-2	B946-2	B986-2	B943-2	B952-2
Alternator data sheet number	ADS-209	ADS-207	ADS-207	ADS-207	ADS-207	ADS-207
Voltage ranges	120/240	120/240	120/208	120/240	277/480	347/600
Voltage feature code	R104-2	R104-2	R098-2	R106-2	R002-2	R114-2
Surge kW	112.4	111.6	116.1	116.1	117.5	117.5
Motor starting kVA (at 90% sustained voltage) Shunt			360	360	360	360
Motor starting kVA (at 90% sustained voltage) PMG			423	423	423	423
Full load current amps at standby rating	417	417	347	301	150	120

Alternator data

Standard Alternators	Single phase ²		Three phase ¹			
Maximum temperature rise above 40 °C ambient	105 °C	105 °C	105 °C	105 °C	105 °C	105 °C
Feature code	BB91-2	BB93-2	BB94-2	BB95-2	BB92-2	BB92-2
Alternator data sheet number	ADS-208	ADS-208	ADS-208	ADS-207	ADS-207	ADS-207
Voltage ranges	120/240	120/208	120/240	277/480	347/600	347/600
Voltage feature code	R104-2	R098-2	R106-2	R002-2	R114-2	R114-2
Surge kW	113.2	118.1	118.1	117.5	117.5	117.5
Motor starting kVA (at 90% sustained voltage) Shunt		422	422	360	360	360
Motor starting kVA (at 90% sustained voltage) PMG		497	497	423	423	423
Full load current amps at standby rating	417	347	301	150	120	120

Notes:

¹ Single phase power can be taken from a three phase generator set at up to 2/3 set rated 3-phase kW at 1.0 power factor

² Full single phase output up to full set rated 3-phase kW at 1.0 power factor

³ Reconnectable option

Formulas for calculating full load currents:

$\frac{\text{Three phase output}}{\text{Voltage} \times 1.73 \times 0.8} = \frac{\text{kW} \times 1000}{\text{Voltage} \times 1.73 \times 0.8}$	$\frac{\text{Single phase output}}{\text{Voltage}} = \frac{\text{kW} \times \text{SinglePhaseFactor} \times 1000}{\text{Voltage}}$
---	--

Warning: Back feed to a utility system can cause electrocution and/or property damage. Do not connect to any building's electrical system except through an approved device or after building main switch is open.

North America
1400 73rd Avenue N.E.
Minneapolis, MN 55432
USA

Phone 763 574 5000
 Fax 763 574 5298

Our energy working for you.™

©2018 Cummins Inc. All rights reserved.
 Cummins is a registered trademarks of Cummins Inc. PowerCommand, AmpSentry, InPower and "Our energy working for you." are trademarks of Cummins. Other company, product, or service names may be trademarks or service marks of others. Specifications are subject to change without notice.
 NAD-6336-EN (03/25) A059X437



power.cummins.com



PowerCommand®

1.1 Control System



Description

The PowerCommand control system is a microprocessor-based generator set monitoring, metering and control system designed to meet the demands of today's engine driven generator sets. The integration of all control functions into a single control system provides enhanced reliability and performance compared to conventional generator set control systems. These control systems have been designed and tested to meet the harsh environment in which gensets are typically applied.

Features

Easy to view: HMI 211RS for residential use. 128 x 64 pixel graphic LED backlight LCD.

Easy to use: Tactile buttons for generator set start/stop. Residential Standby display for convenient use.

Modbus® interface: Eliminates need for MODLON.

Progressive protective functions: Advanced Overcurrent Protection – Generator set monitoring & protection.

Digital voltage regulation: Single phase full wave SCR type regulator compatible with either shunt or PMSG systems.

Digital engine speed governing: Provides isochronous frequency regulation.

12 and 24 VDC battery operation.

Automatic mains failure: Smooth & automatic transfer and re-transfer of load from utility to generator set & vice-versa.

Exerciser clock: Runs generator set exerciser routines for dependability of operation.

Warranty and service: Backed by a comprehensive warranty and worldwide distributor service network.

Certification: Suitable for use on generator sets that are designed, manufactured, tested and certified to relevant UL, NFPA, ISO, IEC Mil Std., CE, UKCA and CSA standards.

PowerCommand Digital Generator Set Control PCC 1302



Description

The PowerCommand generator set control is suitable for use on a wide range of generator sets in non-parallel applications. The PowerCommand control is compatible with shunt or PMG excitation style. It is suitable for use with reconnectable or non-reconnectable generators, and it can be configured for any frequency, voltage and power connection from 120-600 VAC Line-to-Line.

Power for this control system is derived from the generator set starting batteries. The control functions over a voltage range from 8 VDC to 30 VDC.

Features

- 12 and 24 VDC battery operation.
- Digital voltage regulation.
- Digital engine speed governing (where applicable) - Provides isochronous frequency regulation.
- Full authority engine communications (where applicable) - Provides communication and control with the Engine Control Module (ECM).
- Common harnessing - with higher feature Cummins controls allows for easy field upgrades.
- Generator set monitoring - Monitors status of all critical engine and alternator functions.
- Digital genset metering (AC and DC).
- Genset battery monitoring system - to sense and warn against a weak battery condition.
- Engine starting - Includes relay drivers for starter, fuel shut off (FSO), glow plug/spark ignition power and switch B+ applications.
- Generator set protection - Protects engine and alternator.
- Advanced serviceability - using InPower™, a PC-based software service tool.
- Environmental protection - The control system is designed for reliable operation in harsh environments. The main control board is a fully encapsulated module that is protected from the elements.
- Exerciser function – Routine exercising of generator set.
- Supports dual fuel control.
- Automatic Mains Failure function built in generator set controller. Modbus interface - for interconnecting to customer equipment.

- Configurable inputs and outputs - Four discrete inputs and two dry contact relay outputs.
- Warranty and service - Backed by a comprehensive warranty and worldwide distributor service network.
- Certifications - Suitable for use on generator sets that are designed, manufactured, tested and certified to relevant UL, NFPA, ISO, IEC, Mil Std., CE, UKCA and CSA standards.

Base Control Functions

HMI capability

Operator adjustments - The HMI includes provisions for many set up and adjustment functions.

Generator set hardware data - Access to the control and software part number, generator set rating in kVA and generator set model number is provided from the HMI or InPower™.

Data logs - Includes engine run time, controller on time, number of start attempts.

Fault history - Provides a record of the most recent fault conditions with control hours time stamp. Up to 10 events are stored in the control non-volatile memory.

Alternator data

- Voltage (single or three phase Line-to-Line and Line-to-Neutral)
- Current (single or three phase)
- kVA (three phase and total)
- Frequency
- Engine data
- Starting battery voltage
- Engine speed
- Engine temperature
- Engine oil pressure
- Partial Full Authority Engine (FAE) data (where applicable)
- Service adjustments - The HMI includes provisions for adjustment and calibration of generator set control functions. Adjustments are protected by a password. Functions include:
 - Engine speed governor adjustments
 - Voltage regulation adjustments
 - Cycle cranking
 - Configurable fault set up
 - Configurable output set up
 - Meter calibration
 - Units of measurement

Engine control

SAE-J1939 CAN interface to full authority ECMs (where applicable) - Provides data swapping between genset and engine controller for control, metering and diagnostics.

12 VDC/24 VDC battery operations - PowerCommand will operate either on 12 VDC or 24 VDC batteries.

Isochronous governing (where applicable) - Capable of controlling engine speed within +/-0.25% for any steady state load from no load to full load. Frequency drift will not exceed +/-0.5% for a 33 °C (60 °F) change in ambient temperature over an 8 hour period.

Temperature dependent governing dynamics (with electronic governing) - Modifies the engine governing control parameters as a function of engine temperature. This allows the engine to be more responsive when warm and more stable when operating at lower temperature levels.

Remote start mode - Accepts a ground signal from remote devices to automatically start the generator set and immediately accelerate to rated speed and voltage. The remote start signal will also wake up the control from sleep mode. The control can incorporate a time delay start and stop.

Remote and local Emergency stop - The control accepts a ground signal from a local (genset mounted) or remote (facility mounted) Emergency stop switch to cause the generator set to immediately shut down. The generator set is prevented from running or cranking with the switch engaged. If in sleep mode, activation of either Emergency stop switch will wake up the control.

Sleep mode - The control includes a configurable low current draw state to minimize starting battery current draw when the genset is not operating. The control can also be configured to go into a low current state while in auto for Prime applications or applications without a battery charger.

Engine starting - The control system supports automatic engine starting. Primary and backup start disconnects are achieved by one of three methods: magnetic pickup, battery charging alternator feedback or main alternator output frequency. The control also supports configurable glow plug control when applicable.

Cycle cranking - Configurable for the number of starting cycles (1 to 7) and duration of crank and rest periods. Control includes starter protection algorithms to prevent the operator from specifying a starting sequence that might be damaging.

Time delay start and stop (cooldown) - Configurable for time delay of 0-300 seconds prior to starting after receiving a remote start signal and for time delay of 0-600 seconds prior to shut down after signal to stop in normal operation modes. Default for both time delay periods is 0 seconds.

Alternator control

The control includes an integrated line-to-line sensing voltage regulation system that is compatible with shunt or PMG excitation systems. The voltage regulation system is full wave rectified and has an SCR output for good motor starting capability. Major system features include:

Digital output voltage regulation - Capable of regulating output voltage to within +/-1.0% for any loads between no load and full load. Voltage drift will not exceed +/-1.5% for a 40 °C (104 °F) change in temperature in an eight hour period. On engine starting or sudden load acceptance, voltage is controlled to a maximum of 5% overshoot over nominal level.

The automatic voltage regulator feature can be disabled to allow the use of an external voltage regulator.

Torque-matched V/Hz overload control - The voltage roll-off set point and rate of decay (i.e. the slope of the V/Hz curve) is adjustable in the control.

Protective Functions

On operation of a protective function the control will indicate a fault by illuminating the appropriate status LED on the HMI, as well as display the fault code and fault description on the LCD. The nature of the fault and time of occurrence are logged in the control. The service manual and InPower service tool provide service keys and procedures based on the service codes provided. Protective functions include:

Battle short mode

When enabled and the battle short switch is active, the control will allow some shutdown faults to be bypassed. If a bypassed shutdown fault occurs, the fault code and description will still be annunciated, but the genset will not shutdown. This will be followed by a fail to shutdown fault. Emergency stop shutdowns and others that are critical for proper operation are not bypassed. Please refer to the Control Application Guide or Manual for list of these faults.

Configurable alarm and status inputs

The control accepts up to four alarm or status inputs (configurable contact closed to ground or open) to indicate a configurable (customer-specified) condition. The control is programmable for warning, shutdown or status indication and for labelling the input.

Emergency stop

Annunciated whenever either Emergency stop signal is received from external switch.

General engine protection

Low and high battery voltage warning - Indicates status of battery charging system (failure) by continuously monitoring battery voltage.

Weak battery warning - The control system will test the battery each time the generator set is signaled to start and indicate a warning if the battery indicates impending failure.

Fail to start (overcrank) shutdown - The control system will indicate a fault if the generator set fails to start by the completion of the engine crank sequence.

Fail to crank shutdown - Control has signaled starter to crank engine but engine does not rotate.

Cranking lockout - The control will not allow the starter to attempt to engage or to crank the engine when the engine is rotating.

Hydro mechanical fuel system engine protection

Overspeed shutdown - Default setting is 115% of nominal.

Low lube oil pressure warning/shutdown - Level is pre-set (configurable with InPower) to match the capabilities of the engine used. Control includes time delays to prevent nuisance alarms.

High lube oil temperature warning/shutdown - Level is pre-set (configurable with InPower) to match the capabilities of the engine used. Control includes time delays to prevent nuisance alarms.

High engine temperature warning/shutdown - Level is pre-set (configurable with InPower) to match the capabilities of the engine used. Control includes time delays to prevent nuisance alarms.

Low coolant temperature warning - Indicates that engine temperature may not be high enough for a 10 second start or proper load acceptance.

Sensor failure indication - Logic is provided on the base control to detect analog sensor or interconnecting wiring failures.

Full authority electronic engine protection

Engine fault detection is handled inside the engine ECM. Fault information is communicated via the SAE-J1939 data link for annunciation in the HMI

Alternator protection

High AC voltage shutdown (59) - Output voltage on any phase exceeds pre-set values. Time to trip is inversely proportional to amount above threshold. Values adjustable from 105-130% of nominal voltage, with time delay adjustable from 0.1-10 seconds. Default value is 110% for 10 seconds.

Low AC voltage shutdown (27) - Voltage on any phase has dropped below a pre-set value. Adjustable over a range of 50-95% of reference voltage, time delay 2-20 seconds. Default value is 85% for 10 seconds.

Overcurrent warning/shutdown - Implementation of the thermal damage curve with instantaneous trip level calculated based on current transformer ratio and application power rating.

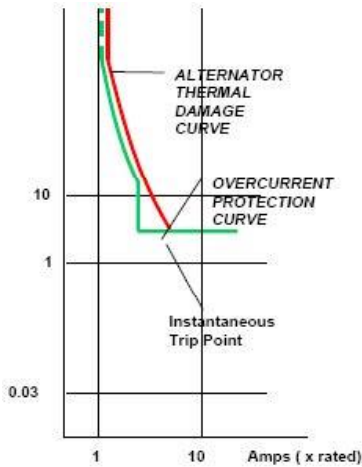

Under frequency shutdown (81 u) - Generator set output frequency cannot be maintained. Settings are adjustable from 2-10 Hz below nominal governor set point, for a 5-20 second time delay. Default: 6 Hz, 10 seconds.

Over frequency shutdown/warning (81 o) - Generator set is operating at a potentially damaging frequency level. Settings are adjustable from 2-10 Hz above nominal governor set point for a 1-20 second time delay. Default: 6 Hz, 10 seconds, enabled.

Loss of sensing voltage shutdown - Shutdown of generator set will occur on loss of voltage sensing inputs to the control.

Field overload shutdown - Uses field voltage to shutdown generator set when a field overload condition occurs.

Advanced Functions

Automatic mains failure*

The built in AMF feature provides the automatic transfer and re-transfer of the load from utility to generator set and vice-versa.

- Automatically starts-stops the generator set in the event of utility failure.
- Annunciates faults.

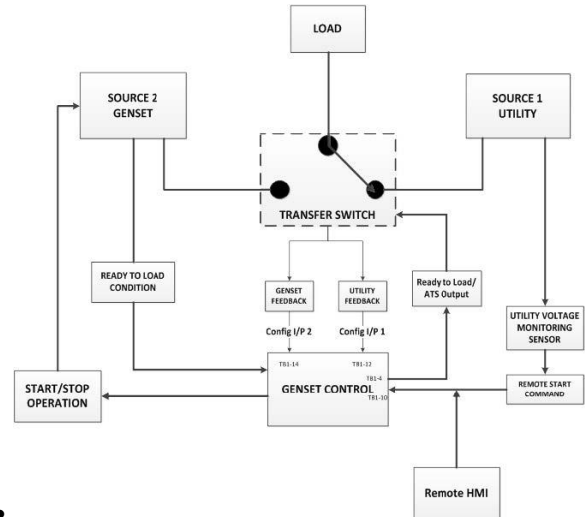

- * A utility voltage monitoring sensor (as shown in the AMF diagram above) must be connected in order to use the AMF feature on the 1302 control. Use Schneider Electric Relay RSB1A120U7 and Socket RSZE1S35M.

Exerciser clock

The exerciser clock runs the generator set exerciser routines for dependability of operation.

Field Control Interface

Input signals to the base control include:

- Remote start
- Local and Emergency stop
- Configurable inputs: Control includes (4) input signals from customer discrete devices that are configurable for warning, shutdown or status indication, as well as message displayed.

Output signals from the PowerCommand control include:

- Configurable relay outputs: Control includes (2) relay output contacts rated at 2 A. These outputs can be configured to activate on any control warning or shutdown fault as well as ready to load, not in auto, common alarm, common warning and common shutdown.
- Ready to load (generator set running) signal: Operates when the generator set has reached 90% of rated speed and voltage and latches until generator set is switched to off or idle mode.

PowerCommand Human Machine Interface HMI211



Description

This control system includes an intuitive operator interface panel that allows for complete genset control as well as system metering, fault annunciation, configuration and diagnostics. The interface includes five generator set status LED lamps with both internationally accepted symbols and English text to comply with customer needs. The interface also includes an LED backlit LCD display with tactile feel soft-switches for easy operation and screen navigation. It is configurable for units of measurement and has adjustable screen contrast and brightness.

The *run/off/auto* switch function is integrated into the interface panel.

All data on the control can be viewed by scrolling through screens with the navigation keys. The control displays the current active fault and a time-ordered history of the five previous faults.

Features

- LED indicating lamps:
 - Remote start
 - Not in auto
 - Shutdown
 - Warning
 - Auto
 - Run
- 128 x 64 pixels graphic LED backlight LCD.
- Four tactile feel membrane switches for LCD defined operation. The functions of these switches are defined dynamically on the LCD.
- Two tactile feel membrane switches dedicated for off and back.
- Allows for complete genset control setup.
- Certifications: Suitable for use on generator sets that are designed, manufactured, tested and certified to relevant UL, NFPA, ISO, IEC, Mil Std., CE, UKCA and CSA standards.
- HMI 211RS provides convenience for residential use.

Communications Connections

PC tool interface - This RS-485 communication port allows the HMI to communicate with a personal computer running InPower.

This RS-485 communication port allows the HMI to communicate with the main control board.

Mechanical Drawing

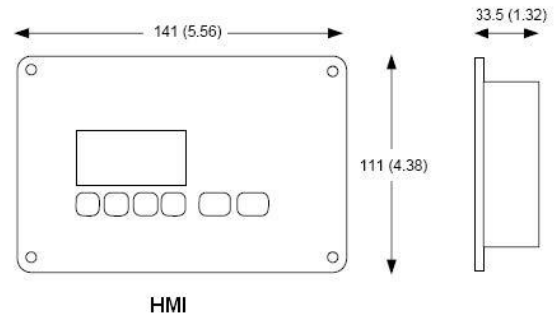

Dimensions: mm (inches)

Software

InPower (beyond 6.0 version) is a PC-based software service tool that is designed to directly communicate to PowerCommand generator sets and transfer switches, to facilitate service and monitoring of these products.

Environment

The control is designed for proper operation without recalibration in ambient temperatures from -40 °C (-40 °F) to +70 °C (158 °F), and for storage from -55 °C (-67 °F) to +80 °C (176 °F). Control will operate with humidity up to 95%, non-condensing.

The HMI is designed for proper operation in ambient temperatures from -40 °C* (-40 °F) to +70 °C (158 °F), and for storage from -40 °C* (-40 °F) to +80 °C (176 °F).

The control board is fully encapsulated to provide superior resistance to dust and moisture. Display panel has a single membrane surface, which is impervious to effects of dust, moisture, oil and exhaust fumes. This panel uses a sealed membrane to provide long reliable service life in harsh environments.

The control system is specifically designed and tested for resistance to RFI/EMI and to resist effects of vibration to provide a long reliable life when mounted on a generator set. The control includes transient voltage surge suppression to provide compliance to referenced standards.

* Heater accessory (pn: A040H853) is available for enhanced operation below -20 °C

Certifications

PowerCommand meets or exceeds the requirements of the following codes and standards:

- NFPA 110 for level 1 and 2 systems.
- ISO 8528-4: 1993 compliance, controls and switchgear.
- CE and UKCA marking: The control system is suitable for use on generator sets to be CE and UKCA-marked.
- EN 50081-1,2 residential/light industrial emissions or industrial emissions.
- EN 50082-1,2 residential/light industrial or industrial susceptibility.
- ISO 7637-2, level 2: DC supply surge voltage test.
- Mil Std. 202C, Method 101 and ASTM B117: Salt fog test.
- PowerCommand control systems and generator sets are designed and manufactured in ISO 9001 certified facilities.
- UL 6200 recognized and suitable for use on UL 2200 Listed generator sets.
- CSA C282-M1999 compliance.
- CSA 22.2 No. 14 M91 industrial controls.

Warranty

All components and subsystems are covered by an express limited one year warranty. Other optional and extended factory warranties and local distributor maintenance agreements are available

Accessories

1301-1302 Upgrade Kit (HM)	0541-1431
PowerCommand 500 (LAN)	A040X126
Remote HMI 211	0541-1394
Remote HMI 211RS	A046K103
I/O Expansion (Aux 101)	0541-1291
HMI Heater Accessory Kit	A040H853

Parts Ordering Information

1302 Control Board	0327-1617-02
1302 control Board – Arrow	A043W505
Aux 104 (Governor Control)	0327-1507
HMI 211 Without Heater	0300-6014
HMI 211 with Heater	A026G237

Additional Resources

Resource	Where to find
1302 Service Manual	QSOL
Accessories Catalog	cumminspower.com
Additional Controls Information	PowerSuite Library



For more information contact your local Cummins distributor or visit power.cummins.com

Our energy working for you.™





Dual wall sub-base diesel fuel tanks - 10-200 kW generator sets



Description

Cummins® offers two series of fuel tanks (basic series and regional series) for the 10~125 kW diesel generator sets. The “basic” series of fuel tanks provide economical solutions for areas with no or minimal local/regional code requirements on diesel fuel tanks. The footprint of “basic” tanks matches the generator set’s footprint. The “regional” series of fuel tanks provide flexible and upgradable solutions for areas with extensive local/regional code requirements on diesel fuel tanks. The footprint of the “regional” series of fuel tanks extends beyond the generator set to allow room for installation of optional features at factory or accessories in the field for meeting local/regional code requirements or customer specification on diesel fuel tanks. All fuel tanks and optional features are compatible with factory installed enclosures.

These tanks are constructed of heavy gauge steel and include an internally reinforced baffle structure for supporting the generator set. The fuel tank design features fewer seams and welds for better corrosion resistance performance.

These tanks are pre-treated with a conversion coating and then finished with a textured powder paint. The paint has superior UV and chemical resistance with best-in-class adhesion, flexibility, and durability to resist chipping and substrate corrosion. Both interior compartments are treated with a rust preventative for extended corrosion protection.

These tanks are UL and ULC Listed as secondary containment generator base tanks. Inner and outer containments are leak checked per UL and ULC testing procedures to ensure their integrity.

These fuel tanks are offered in various sizes to satisfy different fuel capacities requirements.

Compatible generator set model

Engine	D1703M	V2203M	4BT3.3-G5	4BTAA3.3-G7	QSB5-G5	QSB7-G5
Generator set model names	C10D6	C20D6	C25D6	C50D6	C50D6C	C125D6D
	C15D6		C30D6	C60D6	C60D6C	C150D6D
			C35D6		C80D6C	C175D6D
			C40D6		C100D6C	C200D6D
					C125D6C	

Basic fuel tanks

Standard features:

UL 142 and ULC-S601 listed - Minimum 110% secondary containment capacity.

NFPA and IFC - Capable of meeting NFPA 30 and NFPA 110 codes with available factory installed optional features.

Emergency pressure relief vents - Ensure adequate ventilation of the primary and secondary tank compartments under extreme temperature and emergency conditions.

Normal atmospheric vent - "Mushroom" style vent ensures adequate venting of the primary tank during fill, generator set running and temperature variations. Raised above fuel fill.

Raised fuel fill - includes lockable sealed fuel cap.

Lifting eyes - Allow lifting of fuel tank with generator set installed.

Optional features:

Secondary containment basin switch (rupture switch) - Activates a warning in the event of a primary tank leak. Side mounted.

Low fuel level switch - Activates a warning when 40% of the fuel is left in the tank.

Fuel level gauge - Provides direct reading of fuel level. Top mounted.

Electric fuel level sender with gauge - Allows remote electrical monitoring of fuel tank level. Flying leads for customer connection.

Tank to foundation clearance - 2-inch bolt-thru risers allow visual inspection under tank including rodent barrier.

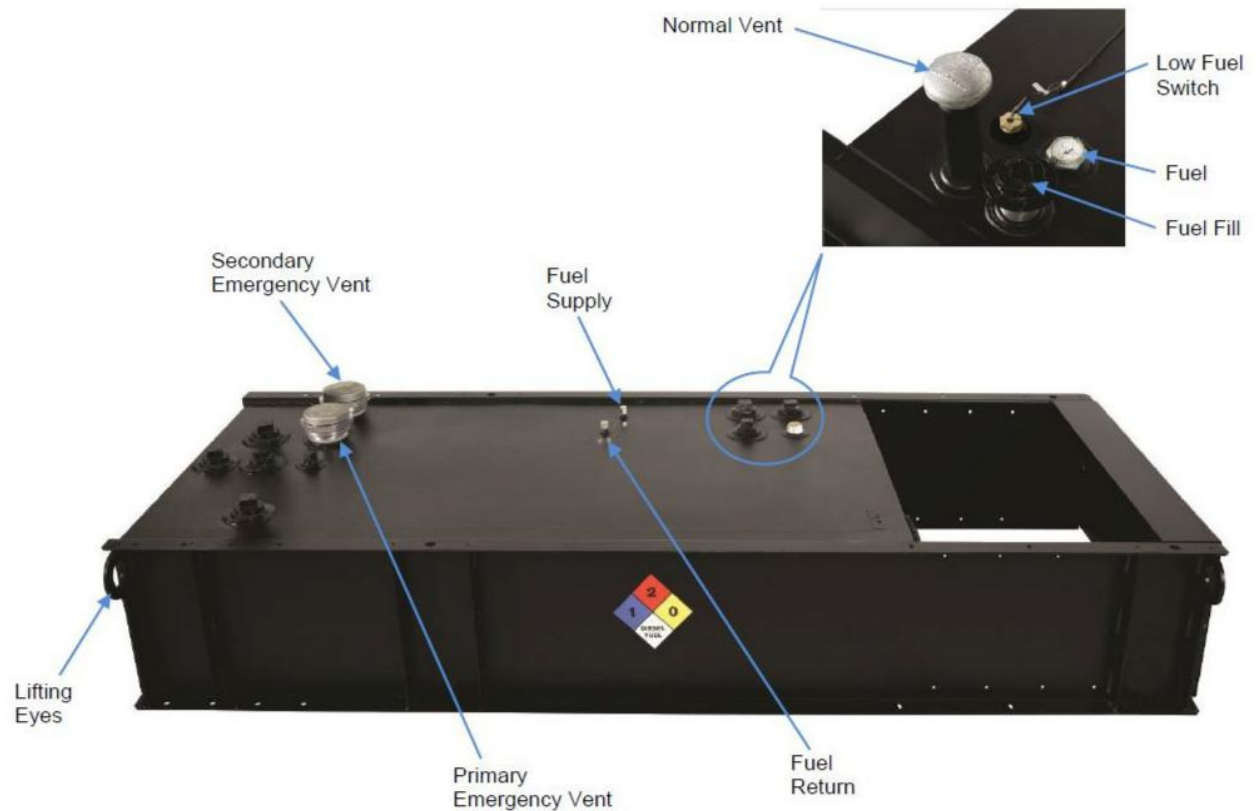

*Picture is for reference only. See outline drawing for tank specific information by model.

Basic tanks

Generator set Standby power output	Generator set model	Engine model	Fuel consumption (100% load, Standby)	Tank feature code	Minimum run time feature	Tank dimensions (L x W x H)	Nominal dry weight*	Tank usable volume	Actual run time
kW			gal/hr		hr	inch	lbs	gal	hr
10	C10D6	D1703M	1.12	C319-2	24	65.7 x 34 x 13	310	46	41
				C320-2	48	65.7 x 34 x 23	583	91	81
15	C15D6	D1703M	1.38	C319-2	24	65.7 x 34 x 13	310	46	33
				C320-2	48	65.7 x 34 x 23	583	91	66
20	C20D6	V2203M	1.81	C319-2	24	65.7 x 34 x 13	310	46	25
				C320-2	48	65.7 x 34 x 23	583	91	50
25	C25D6	4BT3.3-G5	2.42	C319-2	24	87.6 x 34 x 15	456	74	31
				C320-2	48	87.6 x 34 x 23	669	132	54
30	C30D6	4BT3.3-G5	2.81	C319-2	24	87.6 x 34 x 15	456	74	26
				C320-2	48	87.6 x 34 x 32	908	195	69
35	C35D6	4BT3.3-G5	3.16	C319-2	24	87.6 x 34 x 23	669	132	42
				C320-2	48	87.6 x 34 x 32	908	195	62
40	C40D6	4BT3.3-G5	3.66	C319-2	24	87.6 x 34 x 23	669	132	36
				C320-2	48	87.6 x 34 x 32	908	195	53
50	C50D6	4BTAA3.3-G7	4.25	C319-2	24	87.6 x 34 x 23	669	132	31
				C320-2	48	87.6 x 34 x 42	977	263	62
60	C60D6	4BTAA3.3-G7	5.04	C319-2	24	87.6 x 34 x 23	669	132	26
				C320-2	48	87.6 x 34 x 42	977	263	52
50	C50D6C	QSB5-G5	5.30	C319-2	24	117 x 40 x 25	809	260	49
				C320-2	48	117 x 40 x 25	809	260	49
60	C60D6C	QSB5-G5	6.10	C319-2	24	117 x 40 x 25	809	260	42
				C320-2	48	117 x 40 x 33	966	353	57
80	C80D6C	QSB5-G5	7.30	C319-2	24	117 x 40 x 25	809	260	35
				C320-2	48	117 x 40 x 33	966	353	48
100	C100D6C	QSB5-G5	8.90	C319-2	24	117 x 40 x 25	809	260	29
				C320-2	48	117 x 40 x 48	1471	526	59
125	C125D6C	QSB5-G6	10.30	C319-2	24	117 x 40 x 25	809	260	25
				C320-2	48	117 x 40 x 48	1471	526	51
125	C125D6D	QSB7-G5	10.1	C319-2	24	117x40x25	809	258	25
				C320-2	48	117x40x48	1471	520	51
150	C150D6D		11.7	C319-2	24	117x40x33	966	350	29
				C320-2	48	180x40x42	2302	737	62
175	C175D6D		13.3	C319-2	24	117x40x33	966	350	26
				C320-2	48	180x40x42	2302	737	55
200	C200D6D	14.9	C319-2	24	117x40x48	1471	520	34	
			C320-2	48	180x40x42	2302	737	49	

Note: No OFPV is offered on basic fuel tanks.

* All weights are approximate.

Regional tanks

Generator set Standby power output	Generator set model	Engine model	Fuel consumption (100% load, Standby)	Tank feature code	Minimum run time feature	Tank dimensions (L x W x H)	Nominal dry weight*	Tank usable volume	Actual run time w/o OFFV	Actual run time w/OFPV
kW			gal/hr		hr	inch	lbs	gal	hr	hr
125	C125D6D	QSB7-G5	10.1	C301-2	24	180x40x21	1477	351	34	30
				C303-2	48	180x40x42	2302	737	72	69
				C305-2	72	180x40x42	2302	737	72	69
				C307-2	96	180x65.5x35.3	3552	1055	104	98
150	C150D6D		11.7	C301-2	24	180x40x21	1477	351	30	26
				C303-2	48	180x40x42	2302	737	63	59
				C305-2	72	180x65.5x35.3	3552	1055	90	84
175	C175D6D		13.3	C301-2	24	180x40x21	1477	351	26	23
				C303-2	48	180x40x42	2302	737	55	52
				C305-2	72	180x65.5x35.3	3552	1055	79	74
200	C200D6D		14.9	C301-2	24	180x40x21	1477	351	24	21
				C303-2	48	180x40x42	2302	737	49	47
		C305-2		72	180x65.5x35.3	3552	1055	72	66	

Certifications/standards/codes



UL 142 Listed - Cummins dual wall sub-base tanks are UL Listed and constructed in accordance with Underwriters Laboratories Standard UL 142 "steel aboveground tanks for flammable and combustible liquids," as a "secondary containment generator base tank"



NFPA - Cummins tanks are built in accordance with all applicable NFPA codes:

- NFPA 30 - Flammable and Combustible Liquids code
- NFPA 37 - Standard for Installation and use of Stationary Combustible Engine and Gas Turbines
- NFPA 110 - Standard for Emergency and Standby Power Systems



ISO9001 - This product was designed and manufactured in facilities certified to ISO9001.



ULC - Cummins tanks are built in accordance with all applicable ULC codes

For more information contact your local Cummins distributor or visit power.cummins.com

Our energy working for you.™



2025 EPA Tier 3 Exhaust Emission Compliance Statement

C100D6C

Stationary Emergency 60 Hz Diesel Generator Set

Compliance Information:

The engine used in this generator set complies with Tier 3 emissions limit of U.S. EPA New Source Performance Standards for stationary emergency engines under the provisions of 40 CFR 60 Subpart IIII.

Engine Manufacturer:	Cummins Inc.
EPA Certificate Number:	SCEXL0275AAK-037
Effective Date:	1/27/2025
Date Issued:	1/27/2025
EPA Engine Family (Cummins Emissions Family):	SCEXL0275AAK

Engine Information:

Model:	QSB5-G13	Bore:	4.21 in. (106.9 mm)
Engine Nameplate HP:	173	Stroke:	4.88 in. (123.9 mm)
Type:	4 cycle, in-line, 4 cylinder	Displacement:	272 cu. in. (4.45 liters)
Diesel Aspiration:	Turbocharged	Compression Ratio:	17.3:1
Emission Control Device:		Exhaust Stack Diameter:	4 in. (102 mm)

Diesel Fuel Emission Limits

D2 Cycle Exhaust Emissions

	Grams per BHP-hr			Grams per kWm-hr		
	<u>NO_x + NMHC</u>	<u>CO</u>	<u>PM</u>	<u>NO_x + NMHC</u>	<u>CO</u>	<u>PM</u>
EPA Emissions Limit	3.0	2.6	0.15	4.0	3.5	0.20

Test methods: EPA emissions recorded per 40 CFR Part 60, 89, 1039, 1065 and weighted at load points prescribed in the regulations for constant speed engines.

Diesel fuel specifications: Cetane number: 40-50, Reference: ASTM D975 No. 2-D, 300-500 ppm Sulphur

Reference conditions: Air Inlet Temperature: 25 °C (77 °F), Fuel Inlet Temperature: 40 °C (104 °F). Barometric Pressure: 100 kPa (29.53 in Hg), Humidity: 10.7 g/kg (75 grains H₂O/lb) of dry air; required for NO_x correction, Restrictions: Intake Restriction set to a maximum allowable limit for clean filter; Exhaust Back Pressure set to a maximum allowable limit.

Tests conducted using alternate test methods, instrumentation, fuel or reference conditions can yield different results. Engine operation with excessive air intake or exhaust restriction beyond published maximum limits, or with improper maintenance, may result in elevated emission levels.



Exhaust Emission Data Sheet

C100D6C

60 Hz Diesel Generator Set

Engine Information:

Model:	Cummins QSB5-G13	Bore:	4.21 in. (106.9 mm)
Type:	4 cycle, in-line, 4 cylinder diesel	Stroke:	4.88 in. (123.9 mm)
Aspiration:	Turbocharged	Displacement:	272 cu. in. (4.45 liters)
Compression Ratio:	17.3:1	Exhaust Stack Diameter:	3.5 in (88.9 mm)
Emission Control Device:	Turbocharged and charge air-cooled		

<u>Performance Data</u>	<u>1/4 Standby</u>	<u>1/2 Standby</u>	<u>3/4 Standby</u>	<u>Full Standby</u>	<u>Full Prime</u>
BHP @ 1800 RPM (60 Hz)	44	88	132	176	152
Fuel Consumption (gal/Hr)	2.8	4.8	6.9	8.9	7.7
Exhaust Gas Flow (CFM)	388	606	763	878	790
Exhaust Gas Temperature (°F)	496	597	764	913	808
Exhaust Emission Data					
HC (Total Unburned Hydrocarbons)	0.10	0.06	0.03	0.03	0.02
NOx (Oxides of Nitrogen as NO ₂)	2.31	2.22	2.73	3.84	3.70
CO (Carbon Monoxide)	0.76	0.52	0.36	0.52	0.30
PM (Particulate Matter)	0.16	0.23	0.04	0.05	0.03
Smoke (Bosch)	0.76	0.84	0.44	0.65	0.29

All values (except smoke) are cited: g/BHP-hr

Test Conditions

Data is representative of steady-state engine speed (± 25 RPM) at designated genset loads. Pressures, temperatures, and emission rates were stabilized.

Fuel Specification:	ASTM D975 No. 2-D diesel fuel with 0.03-0.05% sulfur content (by weight), and 40-48 cetane number.
Fuel Temperature:	99 \pm 9 °F (at fuel pump inlet)
Intake Air Temperature:	77 \pm 9 °F
Barometric Pressure:	29.6 \pm 1 in. Hg
Humidity:	NOx measurement corrected to 75 grains H ₂ O/lb dry air
Reference Standard:	ISO 8178

The NOx, HC, CO and PM emission data tabulated here are representative of test data taken from a single engine under the test conditions shown above. Data for the other components are estimated. These data are subjected to instrumentation and engine-to-engine variability. Field emission test data are not guaranteed to these levels. Actual field test results may vary due to test site conditions, installation, fuel specification, test procedures and instrumentation. Engine operation with excessive air intake or exhaust restriction beyond published maximum limits, or with improper maintenance, may result in elevated emission levels.



Sound data

C100D6C

QSB5-G13 60Hz Diesel Generator Set

Sound Pressure Level @ 7 meters, dB(A)

See notes 2,5,7-11 listed below

Configuration	Exhaust system	Position (Note 1)								8 Position Average
		1	2	3	4	5	6	7	8	
Standard – Unhoused	Infinite Exhaust	78	80.3	80.6	82.3	78.7	81.7	81.7	80.6	80.7
F216-2 Weather Protective Aluminium	Mounted	80.1	82.1	80.3	82.9	81.1	82.4	81.2	81.5	81.5
F231-2 Sound Attenuated Level 1, Aluminium	Mounted	78.8	75.6	71.6	72.8	72.5	73.2	72.5	75.5	74.7
F217-2 Sound Attenuated Level 2, Aluminium	Mounted	72.6	72.9	69.7	71	70.9	71.2	71.7	71.8	71.6

Sound Power Level, dB(A)

See notes 2-4, 7 and 8 listed below

Configuration		Octave Band Center Frequency (Hz)										Overall Sound Power Level
		31.5	63	125	250	500	1000	2000	4000	8000	16000	
Standard – Unhoused	Infinite Exhaust	54.3	79.2	89.0	92.1	100.7	102.3	101.8	98.2	94.8	90.6	107.6
F216-2 Weather Protective Aluminium	Mounted	56.1	89.2	99.2	99.8	102.8	103.7	101.7	99.7	95.3	85.8	109.5
F231-2 Sound Attenuated Level 1, Aluminium	Mounted	58.2	86.0	88.8	91.2	95.5	97.5	95.5	92.7	89.4	82.1	102.6
F217-2 Sound Attenuated Level 2, Aluminium	Mounted	57.4	86.1	88.0	89.7	93.1	92.9	90.4	87.8	84.2	74.8	99.0

Exhaust Sound Power Level, dB(A)

See notes 4,6 and 9 listed below

Open Exhaust (No Muffler) @ Rated Load	Octave Band Center Frequency (Hz)									Overall Sound Power Level
	31.5	63	125	250	500	1000	2000	4000	8000	
	57	84	99	105	112	113	116	116	113	122

Note:

1. Sound pressure levels at 1 meter are measured per the requirements of ISO 3744, ISO 8528-10, ANSI S1.13, ANSI S12.1 and European Communities Directive 2000/14/EC as applicable. The microphone measurement locations are 1 meter from a reference parallelepiped just enclosing the generator set (enclosed or unenclosed).
2. Seven-meter measurement location 1 is 7 meters (23 feet) from the generator (alternator) end of the generator set, and the locations proceed counter clockwise around the generator set at 45° angles at a height of 1.2 meters (48 inches) above the ground surface.
3. Sound Power Levels are calculated according to ISO 3744, ISO 8528-10, and or CE (European Union) requirements.
4. Exhaust Sound Levels are measured and calculated per ISO 6798, Annex A.
5. Reference Sound Pressure Level is 20 µPa.
6. Reference Sound Power Level is 1 pW (10-12 Watt).
7. Sound data for remote-cooled generator sets are based on rated loads without cooling fan noise.
8. Sound data for the generator set with infinite exhaust do not include the exhaust noise contribution.
9. Sound levels are subject to instrumentation, measurement, installation, and manufacturing variability



Sound data

C100D6C

QSB5-G13 60Hz

Diesel Generator Set

10. Unhoused/Open configuration generator sets refers to generator sets with no sound enclosures of any kind
11. Housed/Enclosed/Closed/Canopy configuration generator sets refer to generator sets that have noise reduction sound enclosures installed over the generator set and usually integrally attached to the skid base/base frame/fuel container base of the generator set.



Prototype Test Support (PTS)

60 Hz test summary



<u>Generator set models</u>		<u>Representative prototype</u>	
C50D6C	C80D6C	Model:	C100D6C
C60D6C	C100D6C	Alternator:	UC27 D
		Engine:	QSB5-G5

The following summarizes prototype testing conducted on the designated representative prototype of the specified models. This testing is conducted to verify the complete generator set electrical and mechanical design integrity. Prototype testing is conducted only on generator sets not sold as new equipment.

Maximum surge power: 117.5 kW
 The generator set was evaluated to determine the stated maximum surge power.

Maximum motor starting: 146.3 kVA
 The generator set was tested to simulate motor starting by applying the specified kVA load at low lagging power factor (0.4 or lower). With this load applied, the generator set recovered to a minimum of 90% rated voltage.

Alternator temperature rise:
 The highest rated temperature rise (120 °C) test results are reported as follows to verify that worst case temperature rises do not exceed allowable NEMA MG1 limits for class H insulation. Tests were conducted per IEEE 115, rise by resistance and embedded detector, with the rated voltages. Only the highest temperatures are reported.

<u>Location</u>	<u>Maximum rise (°C)</u>
Alternator stator	N/A
Alternator rotor	N/A
Exciter stator	N/A
Exciter rotor	N/A

Torsional analysis and testing:
 The generator set was tested to verify that the design is not subjected to harmful torsional stresses. A spectrum analysis of the transducer output was conducted.

Cooling system: 50 °C ambient
 0.5 in. H₂O restriction
 The cooling system was tested to determine ambient temperature and static restriction capabilities. The test was performed at full rated load in elevated ambient temperature under static restriction conditions.

Durability:
 The C100D6C generator set was subjected to a minimum 500 hour endurance test operating at variable load up to the Standby rating based upon MIL-STD-705 to verify structural soundness and durability of the design.

Electrical and mechanical strength:
 The generator set was tested to several single phase and three phase faults to verify that the generator can safely withstand the forces associated with short circuit conditions. The generator set was capable of producing full rated output at the conclusion of the testing.

Steady state performance:
 The generator set was tested to verify if the steady state operating performance was within the specified maximum limits.

Voltage regulation:	± 1%
Random voltage variation:	± 1%
Frequency regulation:	± Isochronous
Random frequency variation:	± 0.5%

Transient performance:
 The generator set was tested to verify single step loading capability as required by NFPA 110 and verify acceptable voltage and frequency response on load addition or rejection. The following results were recorded at 1.0 power factor:

Full load acceptance:

Voltage dip:	28%
Recovery time:	1.3 seconds
Frequency dip:	9.1%
Recovery time:	2.6 seconds

Full load rejection:

Voltage rise:	20.2%
Recovery time:	0.6 seconds
Frequency rise:	7.0%
Recovery time:	1.7 seconds

Harmonic analysis:
 (per MIL-STD-705B, method 601.4)

<u>Harmonic</u>	<u>Line to Line</u>		<u>Line to Neutral</u>	
	<u>No load</u>	<u>Full load</u>	<u>No load</u>	<u>Full load</u>
3	0.04	0.15	0.15	0.15
5	0.2	0.2	0.2	0.2
7	0.6	0.6	0.6	0.6
9	0.02	0.04	0.04	0.04
11	0.52	0.52	0.52	0.52
13	0.26	0.26	0.26	0.26
15	0.0	0.0	0.0	0.0



High ambient air temperature radiator cooling system

	Fuel type	Duty	Rating (kW)	Max cooling @ air flow static restriction, unhooded (inches water/mm water)					Housed in free air, no air discharge restriction		
				0.0/0.0	0.25/6.4	0.5/12.7	0.75/19.1	1.0/25.4	F231	F217	F216
				Maximum allowable ambient temperature, degree C							
60 Hz	Diesel	Standby	100	50	50	50	50	N/A	50	50	50
		Prime	90	50	50	50	50	N/A	50	50	50

Notes:

1. Data shown are anticipated cooling performance for typical generator set.
2. Cooling data is based on 1000 ft (305 m) site test location.
3. Generator set power output may need to be reduced at high ambient conditions. Refer generator set data sheet for derate schedules.
4. Cooling performance may be reduced due to several factors including but not limited to: Incorrect installation, improper operation, fouling of the cooling system, and other site installation variables.



Alternator Data Sheet

Frame Size: UC3D

(CGT Frame Name: UCI274D)

Characteristics			No of Bearings:		1-bearing		2-bearing				
Weights:	Stator assembly:		8521 lb	3865 kg	8521 lb	3865 kg					
	Rotor assembly:		4392 lb	1992 kg	4246 lb	1926 kg					
	Complete assembly:		12912 lb	5857 kg	12767 lb	5791 kg					
Maximum speed:		2250 rpm									
Excitation current:		Full load: Wdg 12: 3.6; Wdg 13: 3.6; Wdg 19: 3.14 No load: Wdg 12: 0.86; Wdg 13: 0.86; Wdg 19: 0.86									
Insulation system:		Class H throughout									
3 ∅ Ratings (0.8 power factor)			60 Hz (winding no)								
			<u>190/380</u> (14)	<u>200/400</u> (14)	<u>208/416</u> (14)	<u>600</u> (17)	<u>190/380</u> (311)	<u>200/400</u> (311)	<u>220/440</u> (311)	<u>230/460</u> (311)	<u>240/480</u> (311)
163° C rise ratings	@ 27° C	kW	114	114	114	127	100	114	120	120	127
		kVA	142.5	142.5	142.5	158.8	125	142.5	150	150	158.8
150° C rise ratings	@ 40° C	kW	110	110	110	124	98.4	110	116	116	125
		kVA	137.5	137.5	137.5	155	123	137.5	145	145	156.3
125° C rise ratings	@ 40° C	kW	105	105	105	117	96	105	110	110	117
		kVA	131.3	131.3	131.3	146.3	120	131.3	137.5	137.5	146.3
105° C rise ratings	@ 40° C	kW	96	96	96	105	88	96	100	100	105
		kVA	120	120	120	131.3	110	120	125	125	131.3
80° C rise ratings	@ 40° C	kW	80	80	80	88	72	80	87	87	88
		kVA	100	100	100	110	90	100	108.8	108.8	110
3 ∅ Reactances			<u>190/380</u> (14)	<u>200/400</u> (14)	<u>208/416</u> (14)	<u>600</u> (17)	<u>190/380</u> (311)	<u>208/416</u> (311)	<u>220/440</u> (311)	<u>230/460</u> (311)	<u>240/480</u> (311)
(Based on full load at 125° C rise rating)											
Synchronous			3.08	2.79	2.58	2.02	2.38	2.52	2.36	2.16	2.11
Transient			0.25	0.23	0.21	0.17	0.17	0.21	0.20	0.18	0.17
Subtransient			0.17	0.16	0.14	0.11	0.16	0.15	0.14	0.13	0.12
Negative sequence			0.21	0.19	0.18	0.13	0.11	0.17	0.16	0.15	0.14
Zero sequence			0.12	0.11	0.10	0.08	0.08	0.10	0.09	0.09	0.08
3 ∅ Motor starting			<u>190/380</u> (14)	<u>200/400</u> (14)	<u>208/416</u> (14)	<u>600</u> (17)	<u>190/380</u> (311)	<u>200/400</u> (311)	<u>220/440</u> (311)	<u>230/460</u> (311)	<u>240/480</u> (311)
Maximum kVA (90% sustained voltage)											
(Shunt)			360	360	360	360	360	360	360	360	360
(PMG)			423	423	423	423	423	423	423	423	423
Time constants (sec)			<u>190/380</u> (14)	<u>200/400</u> (14)	<u>208/416</u> (14)	<u>600</u> (17)	<u>190/380</u> (311)	<u>200/400</u> (311)	<u>220/440</u> (311)	<u>230/460</u> (311)	<u>240/480</u> (311)
Transient			0.03	0.03	0.03	0.03	0.031	0.031	0.031	0.031	0.031
Subtransient			0.01	0.01	0.01	0.01	0.01	0.01	0.01	0.01	0.01
Open circuit			0.82	0.82	0.82	0.82	0.85	0.85	0.85	0.85	0.85
DC			0.007	0.007	0.007	0.007	0.0073	0.0073	0.0073	0.0073	0.0073
Windings (@22° C)			<u>190/380</u> (14)	<u>200/400</u> (14)	<u>208/416</u> (14)	<u>600</u> (17)	<u>190/380</u> (311)	<u>200/400</u> (311)	<u>220/440</u> (311)	<u>230/460</u> (311)	<u>240/480</u> (311)
Stator resistance (L-L Ohms)			0.546	0.546	0.546	0.103	0.088	0.088	0.088	0.088	0.088
Rotor resistance (Ohms)			1.26	1.26	1.26	1.26	1.26	1.26	1.26	1.26	1.26
Number of leads			12	12	12	12	12	12	12	12	12



Alternator Data Sheet

Frame Size: UC3D

(CGT Frame Name: UCI274D)

**50
Hz**

Winding 311
THREE PHASE EFFICIENCY CURVES

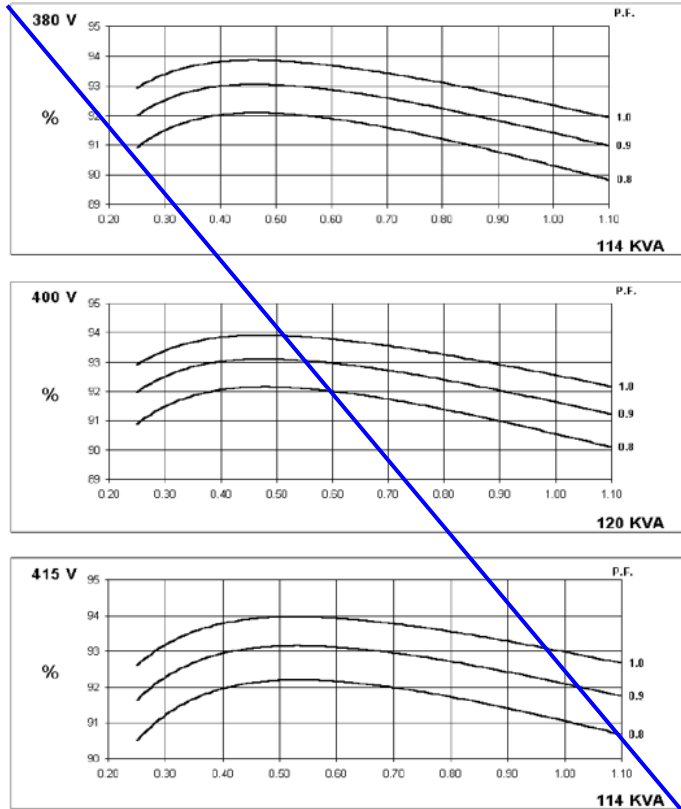

**60
Hz**

Winding 311
THREE PHASE EFFICIENCY CURVES

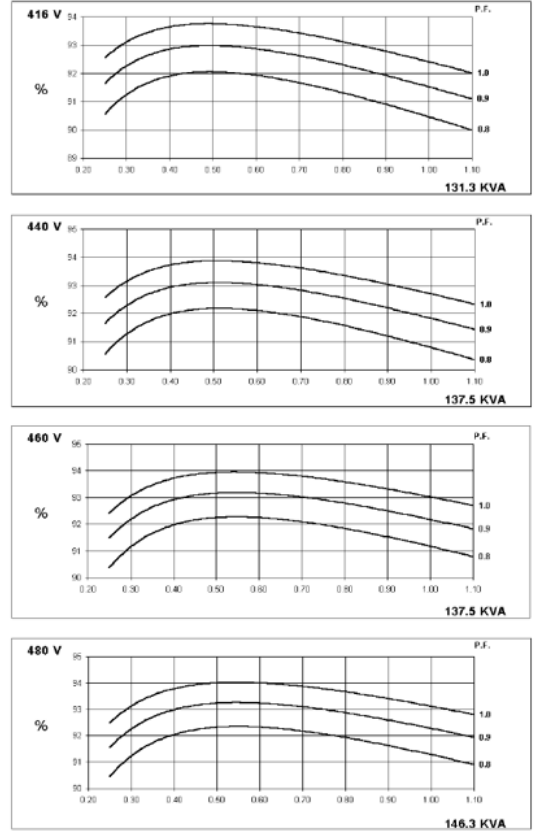



Alternator Data Sheet

Frame Size: UC3D

(CGT Frame Name: UCI274D)

Winding 14

SX

Locked Rotor Motor Starting Curves

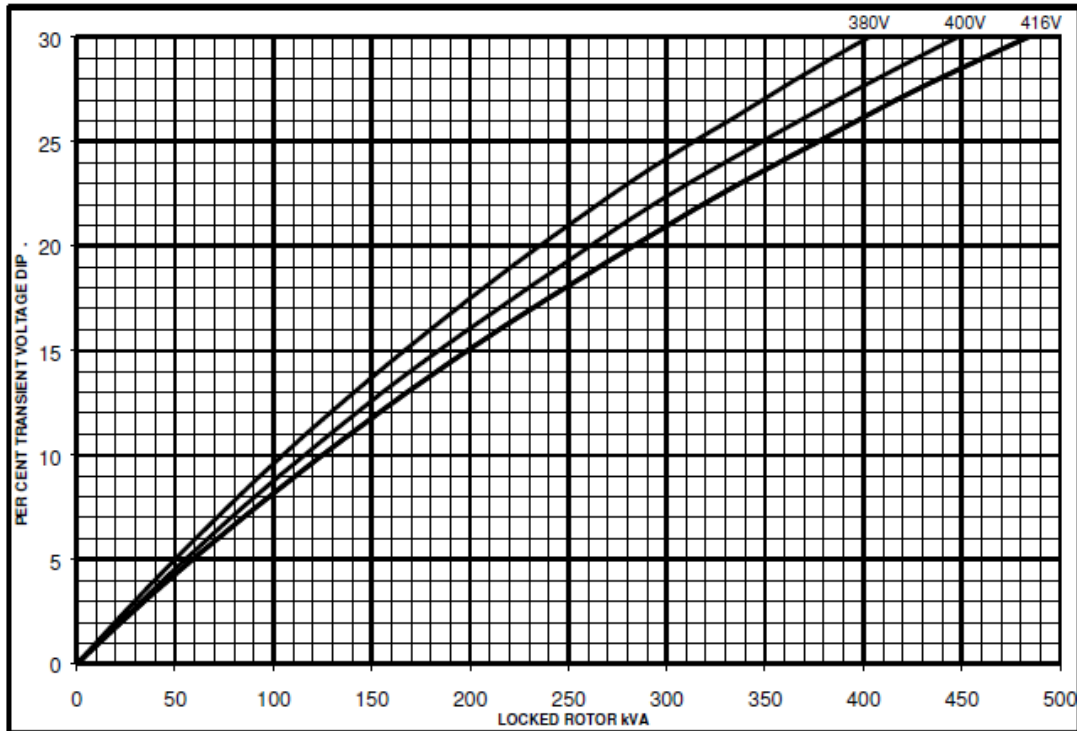

MX

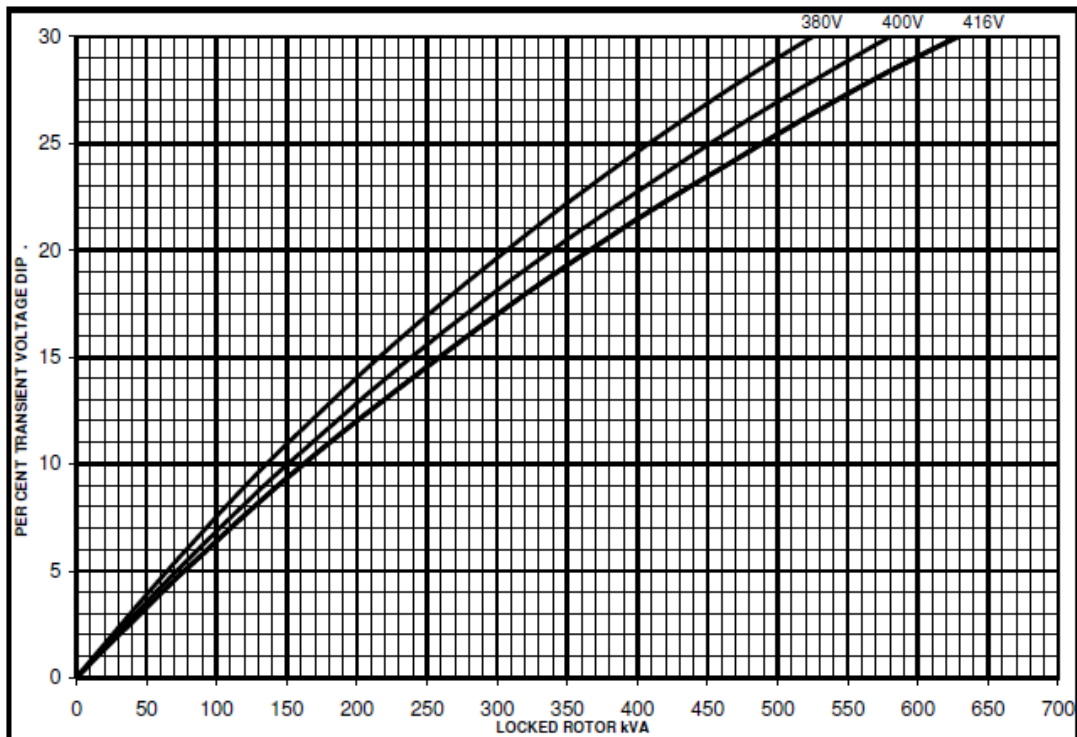



Winding 14

**Three-phase Short Circuit Decrement Curve. No-load Excitation at Rated Speed
 Based on star (wye) connection.**

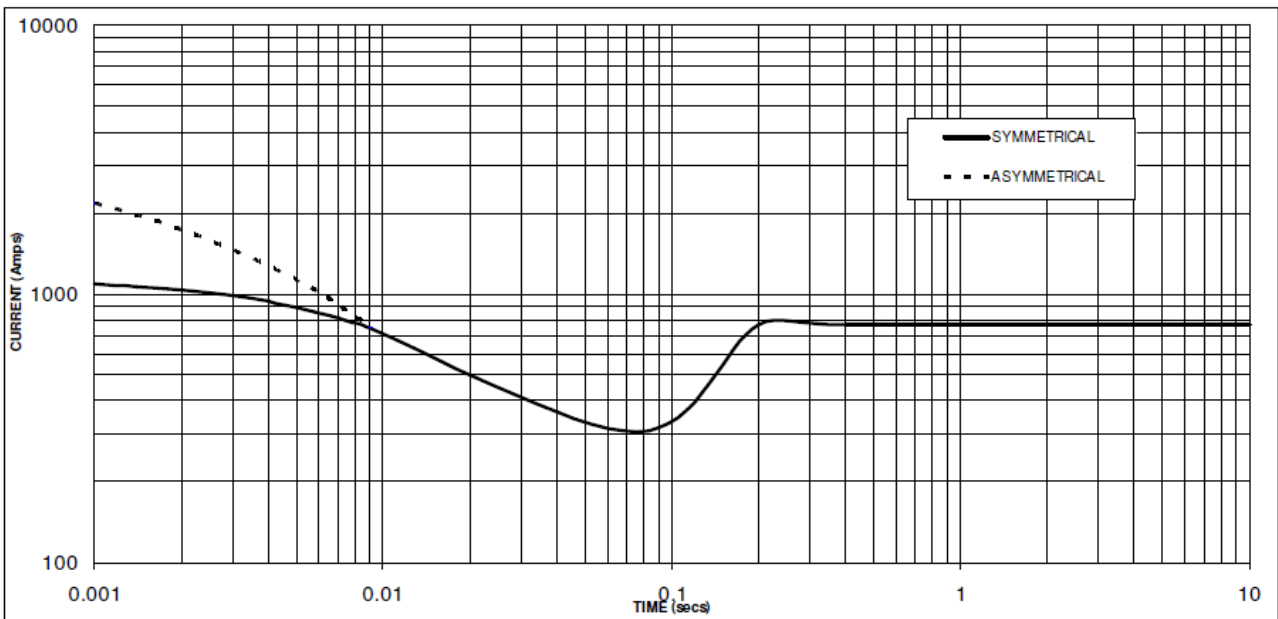

Sustained Short Circuit = 770 Amps

Note

The following multiplication factor should be used to convert the values from curve for the various types of short circuit :

	3-phase	2-phase L-L	1-phase L-N
Instantaneous	x 1.00	x 0.87	x 1.30
Minimum	x 1.00	x 1.80	x 3.20
Sustained	x 1.00	x 1.50	x 2.50
Max. sustained duration	10 sec.	5 sec.	2 sec.

All other times are unchanged

SECTION 3

Generator Accessories





Battery Charger-6 Amp

A045D925 60Hz/50Hz



Description

Cummins® fully automatic battery chargers are designed to both recharge your batteries, and extend your battery's life in applications where it is stored for long periods of time. This charger can handle poor power quality, exposure to extreme weather and rough handling.

To maximize battery life, a 3-stage charging cycle is implemented. The three charging stages are bulk stage, absorption stage and maintenance stage. During the bulk stage, the charger uses its full amp output to do the heaviest charging, quickly bringing your battery to about 75% of capacity. In the absorption stage, the current slows, adjusting for maximum charging efficiency while it gently tops off the battery to about 98% of capacity.

During the maintenance stage, a lower, closely-regulated, constant voltage is applied to maintain full charge and prevent discharge.

Unlike some "trickle chargers," the float charger won't apply more current than necessary to maintain full charge. Batteries can be connected indefinitely, without harm; in fact, the float charge extends battery life.

Features

Protection – Surge protected to IEEE and EN standards. All models include single pole cartridge type fuses mounted on the printed circuit board to protect against input or output overcurrent.

Lightweight and Silent – Lighter than transformer types, completely silent but still provides full output when overloaded outlets drop AC voltage below the normal 115V.

Monitoring – Status LED indicators are provided to show the condition or charging status of the battery. When the red LED is on, it indicates that the battery is discharged and is recharging at the 'BULK' rate. When both the red and green LEDs are on, the battery is charging at the 'midrange' rate. When the green LED is on, the battery is 90% charged and ready for use.

Construction – Made using epoxy-potted cases making it the ultimate in durability, completely waterproof and able to withstand numerous caustic chemicals and gases, as well as being shockproof.

Fault Indication – The charger senses and indicates the following fault conditions: Defective or damaged cells, under-voltage at the battery, battery drawing more current than charger can replace, loss of power or extremely low AC voltage at the charger, other battery fault conditions and charger failure.

Compatibility – Works with Sealed Lead Acid (SLA), Absorbed Glass Mat (AGM) and Gel type batteries.

Low Electromagnetic and Radio

Frequency Interference – This product meets FCC class B for conducted and radiated emissions.

Listed – This product is UL listed according to the UL 1236 Standard.

Warranty – This product has a two year warranty

Specifications

Performance and Physical Characteristics

Output:	Nominal voltage	12 VDC
	Float voltage – 12 V batteries	13.0-13.6 VDC at 0-2 amps
	Maximum output current	6 A @ 12 VDC nom
Input:	Voltage AC	115, 208, 240 ±10%, 90-135
	Frequency	60 Hz ±5%
Battery:	Maximum battery size	150 Amp Hours
	Maximum recharge time	20 hours
Approximate net weight		4 lbs. (1.81 Kg)
Approximate dimensions: height x width x depth-in(mm)		2.25 x 6.4 x 3.5 (57 x 162 x 89)
Ambient temperature operation: At full rated output		-40°F to 122 °F (-40 °C to 50 °C)



Warning: Back feed to a utility system can cause electrocution and/or property damage. Do not connect generator sets to any building electrical system except through an approved device or after building main switch is open.

Warning: For professional use only. Must be installed by a qualified service technician. Improper installation presents hazards of electrical shock and improper operation, resulting in severe personal injury and/or property damage.

For more information contact your local Cummins distributor
or visit power.cummins.com

Our energy working for you.™



Product data sheet

Specifications

SQUARE D

Green Premium™



Circuit breaker, PowerPact L, unit mount, Micrologic 3.3S, 400A, 3 pole, 18kA, 600VAC,

LGL36400U33X

Main

Range	PowerPact
Product name	PowerPact L
Device short name	L-Frame
Product or component type	Circuit breaker
Device application	Distribution

Complementary

[In] rated current	400 A
Number of Poles	3P
Control type	Toggle
Breaking capacity code	G
Breaking capacity	65 kA 240 V AC 50/60 Hz UL 489 35 kA 480 V AC 50/60 Hz UL 489 18 kA 600 V AC 50/60 Hz UL 489 20 kA 250 V DC UL 489 20 kA 500 V DC UL 489
[Ue] rated operational voltage	600 V AC 50/60 Hz IEC 60947-3
Network frequency	50/60 Hz
[Ics] rated service breaking capacity	65 kA 220/240 V AC 50/60 Hz IEC 60947-2 35 kA 380/440/415 V AC 50/60 Hz IEC 60947-2 18 kA 500/525 V AC 50/60 Hz IEC 60947-2 20 kA 250 V DC IEC 60947-2 20 kA 500 V DC IEC 60947-2
[Uimp] rated impulse withstand voltage	8 kV IEC 60947-2
Trip unit technology	Electronic, standard, Micrologic 3.3 S, LSI
[Ui] rated insulation voltage	750 V IEC 60947-2
Trip unit name	Micrologic 3.3 S
Protection technology	Current limiter
Suitability for isolation	Yes IEC 60947-2
Utilisation category	Category A
AWG gauge	Please see CB outline drawing for lug and termination details
Local signalling	Ready 1 LED (green) Alarm 1 LED (90 % Ir orange)

Alarm LED 105 % Ir red)
Switched off (OFF) 1 trip indicator green)

Mounting mode	Unit mount lug)
Mounting support	Lug
Electrical connection	Lugs line Lugs load
Terminal identifier	Please see CB outline drawing for lug and termination details
Long time pick-up adjustment range	0.25...1 x In
Tightening torque	442.54 lbf.in (50 N.m) 0.11...0.37 in ² (70...240 mm ²) AWG 2/0...500 kcmil)
Number of slots	2 auxiliary switch OF plug-in) 1 alarm switch SD plug-in) 1 overcurrent trip switch SDE plug-in) 1 voltage release MN or MX plug-in)
Power wire stripping length	1.22 in (31 mm) 2.40 in (61 mm)
Color	Black
Height	13.39 in (340 mm)
Width	5.51 in (140 mm)
Depth	4.33 in (110 mm)
Net weight	13.67 lb(US) (6.2 kg)
Communication interface	Modbus Ethernet

Environment

Standards	UL CSA NEMA NOM-003-SCFI-2000 IEC 60947-2
Product certifications	UL CSA NOM
IP degree of protection	Front cover IP40
Pollution degree	3 IEC 60947-1
Ambient air temperature for operation	28...158 °F (-2...70 °C)
Ambient air temperature for storage	-58...185 °F (-50...85 °C)
Operating altitude	< 2000 m without derating 5000 m with derating

Packing Units

Unit Type of Package 1	PCE
Number of Units in Package 1	1
Package 1 Weight	15.00 lb(US) (6.804 kg)
Package 1 Height	8.75 in (22.225 cm)
Package 1 width	10.75 in (27.305 cm)
Package 1 Length	19.50 in (49.53 cm)

Offer Sustainability

Sustainable offer status	Green Premium product
REACH Regulation	REACH Declaration

EU RoHS Directive	Compliant EU RoHS Declaration
Mercury free	Yes
RoHS exemption information	Yes
China RoHS Regulation	China RoHS declaration Product out of China RoHS scope. Substance declaration for your information
Environmental Disclosure	Product Environmental Profile
Circularity Profile	End of Life Information
PVC free	Yes

Dimensions

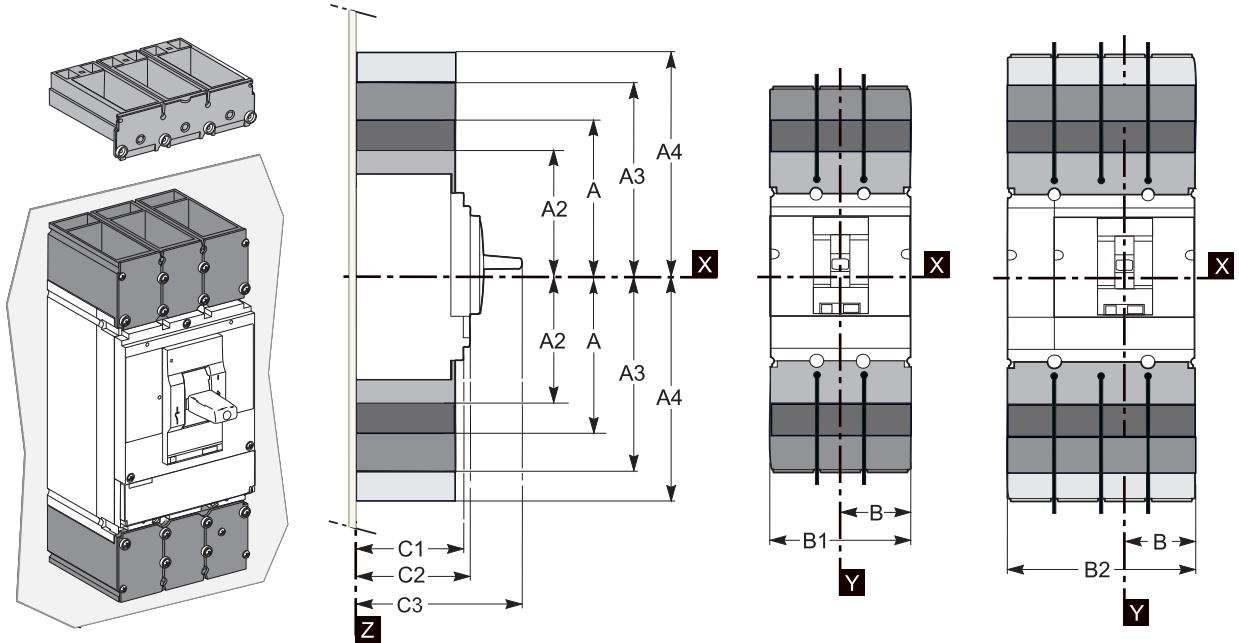

A2 = Short Lug Pack
 AL400L61K3
 CU400L61K3
 AL600LF52K3
 CU600LF5283

A = Medium Lug Pack
 AL400L61K4
 CU400L61K4
 AL600LS52K3
 AL600LS52K4
 CU600LS52K3
 CU600LS52K4

A3 = Long Lug Pack
 Compression Lug Kits
 A4 = 500 Vdc Lug Pack

L-Frame

	A	A2	A3	A4	B	B1	B2	C1	C2	C3
inch	6.69	5.65	7.87	9.53	2.76	5.51	7.28	3.76	4.33	6.61
mm	170	143.5	200	242	70	140	185	105	110	168

All dimensions are approximate.
 Also see CAD, technical drawings, and technical documentation.

PowerPact™ H-, J-, and L-Frame Circuit Breakers Trip Units

Micrologic™ 3 Trip Units

Micrologic 3 trip units can be used on PowerPact H-, J-, and L-Frame circuit breakers with performance levels D/G/J/L.

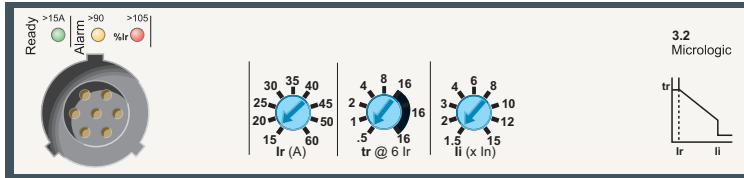

They provide:

- standard protection of distribution cables
- indication of:
 - overloads (using LEDs)
 - overload tripping (using the SDx relay module).

Circuit breakers equipped with Micrologic 3 trip units can be used to protect distribution systems supplied by transformers.

Protection

Settings are made using the adjustment rotary switches.

Overloads: Long time protection (I_r)

Inverse time protection against overloads with an adjustable current pick-up I_r set using a rotary switch and an adjustable time delay t_r .

Neutral protection

- On 3-pole L-frame circuit breakers, neutral protection is not possible.
- On four-pole L-frame circuit breakers, neutral protection may be set using a three-position switch:
 - switch position 4P 3D: neutral unprotected
 - switch position 4P 3D + N/2: neutral protection at half the value of the phase pick-up, ($0.5 \times I_r$)
 - switch position 4P 4D: neutral fully protected at I_r

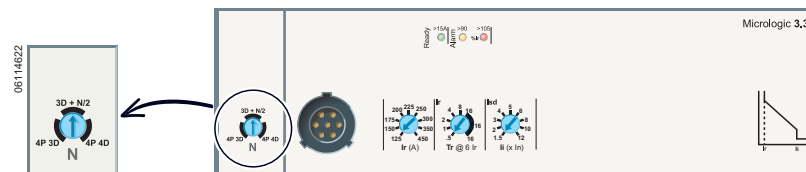

Indicators

Front indicators

- The green “Ready” LED blinks slowly when the electronic trip unit is ready to provide protection. It indicates the trip unit is operating correctly.
- Orange overload pre-alarm LED: steady on when $I > 90\% I_r$
- Red overload LED: steady on when $I > 105\% I_r$

Remote indicators

An overload trip signal can be remotely checked by installing an SDx relay module inside the circuit breaker. This module receives the signal from the Micrologic electronic trip unit through an optical link and makes it available on the terminal block. The signal is cleared when the circuit breaker is reclosed. See page 94.

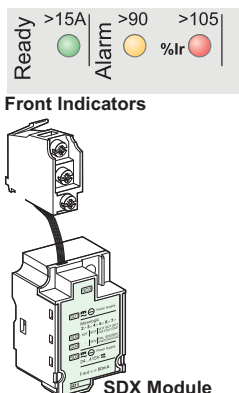

PowerPact™ H-, J-, and L-Frame Circuit Breakers Trip Units

Table 50: Micrologic™ 3 Trip Unit

Ratings	I_n at 104°F (40°C) ¹		60 A	100 A	150 A	250 A	400 A	600 A
Circuit Breaker	H-frame		X	X	X			
	J-frame					X		
	L-frame					X	X	X

Micrologic 3.2 / 3.3 trip units

L Long-time protection

	I_r		Value depending on sensor rating (I_n) and setting on rotary switch									
	Pick-Up (A) Tripping between 1.05 and 1.20 I_r	$I_n = 60$ A	$I_r =$	15	20	25	30	35	40	45	50	60
$I_n = 100$ A		$I_r =$	35	40	45	50	60	70	80	90	100	
$I_n = 150$ A		$I_r =$	50	60	70	80	90	100	110	125	150	
$I_n = 250$ A		$I_r =$	70	80	100	125	150	175	200	225	250	
$I_n = 400$ A		$I_r =$	125	150	175	200	225	250	300	350	400	
$I_n = 600$ A		$I_r =$	200	225	250	300	350	400	450	500	600	
Time Delay (s) Accuracy 0 to -20%	t_r		0.5	1	2	4	8	16				
	$1.5 \times I_r$		15	25	50	100	200	400				
	$6 \times I_r$		0.5	1	2	4	8	16				
		$7.2 \times I_r$	0.35	0.7	1.4	2.8	5.5	11				
Thermal memory			20 minutes before and after tripping									

I Instantaneous

Pick-up (A) accuracy ± 15%	$I_i \times$	60 A	1.5	2	3	4	6	8	10	12	15
		100 A	1.5	2	3	4	6	8	10	12	15
		150 A	1.5	2	3	4	6	8	10	12	15
		250 A	1.5	2	3	4	5	6	8	10	12
		400 A	1.5	2	3	4	5	6	8	10	12
		600 A	1.5	2	3	4	5	6	8	10	11
Non-tripping time Maximum break time		10 ms 50 ms for $I > 1.5 I_i$									

Micrologic 3.2S / 3.3S trip units

L Long-time protection

	I_r		Value depending on sensor rating (I_n) and setting on rotary switch									
	Pick-Up (A) Tripping between 1.05 and 1.20 I_r	$I_n = 60$ A	$I_r =$	15	20	25	30	35	40	45	50	60
$I_n = 100$ A		$I_r =$	35	40	45	50	60	70	80	90	100	
$I_n = 150$ A		$I_r =$	50	60	70	80	90	100	110	125	150	
$I_n = 250$ A		$I_r =$	70	80	100	125	150	175	200	225	250	
$I_n = 400$ A		$I_r =$	125	150	175	200	225	250	300	350	400	
$I_n = 600$ A		$I_r =$	200	225	250	300	350	400	450	500	600	
Time Delay (s) Accuracy 0 to -20%	t_r		non-adjustable									
	$1.5 \times I_r$		400									
	$6 \times I_r$		16									
		$7.2 \times I_r$	11									
Thermal memory			20 minutes before and after tripping									

S Short-time protection

Pick-up (A) accuracy ± 10%	$I_{sd} - I_r \times \dots$		1.5	2	3	4	5	6	7	8	10	
Time delay (ms)	t_{sd}		non-adjustable									
	Non-tripping time Maximum break time		20 80									

I Instantaneous

Pick-up (A) accuracy ± 15%	$I_i \times I_n$		1.5	2	3	4	6	8	10	12	15
Non-tripping time Maximum break time		10 ms 50 ms for $I > 1.5 I_i$									

¹ If the trip units are used in high-temperature environments, the Micrologic trip unit setting must take into account the thermal limitations of the circuit breaker. See the temperature derating information on page 126.

CURRENT IN MULTIPLES OF I_r

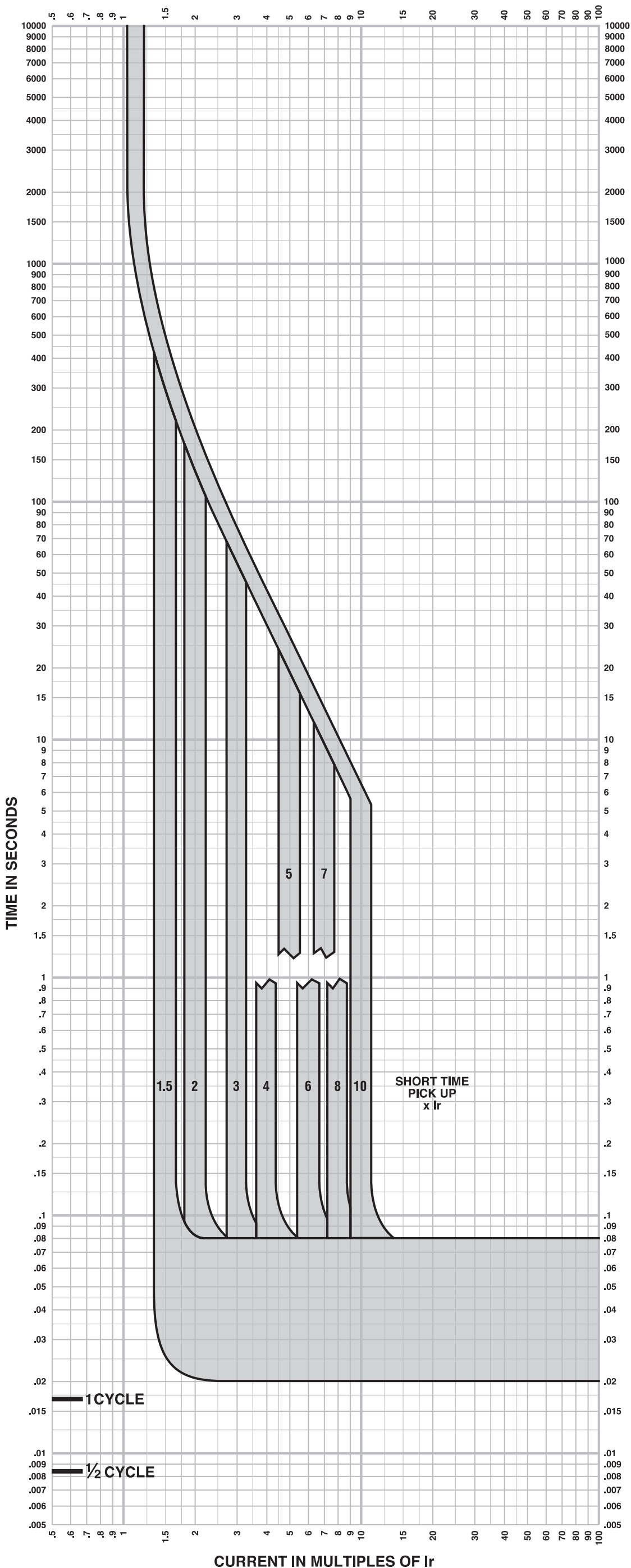

MICROLOGIC™ ELECTRONIC TRIP UNITS
Micrologic™ 3.3S Long Time/
Short Time Trip Curve
250A, 400A L-Frame

The time-current curve information is to be used for application and coordination purposes only.

Notes:

1. There is a thermal-imaging effect that can act to shorten the long-time delay. The thermal imaging effect comes into play if a current above the long-time delay pickup value exists for a time and then is cleared by the tripping of a downstream device or the circuit breaker itself. A subsequent overload will cause the circuit breaker to trip in a shorter time than normal. The amount of time delay reduction is inverse to the amount of time that has elapsed since the previous overload. Approximately 20 minutes is required between overloads to completely reset thermal-imaging.
2. Total clearing times shown include the response times of the trip unit, the circuit breaker opening, and the extinction of the current.

Curves apply from -35°C to $+70^{\circ}\text{C}$ (-31°F to $+158^{\circ}\text{F}$) ambient temperature.

MULTIPLES OF I_n

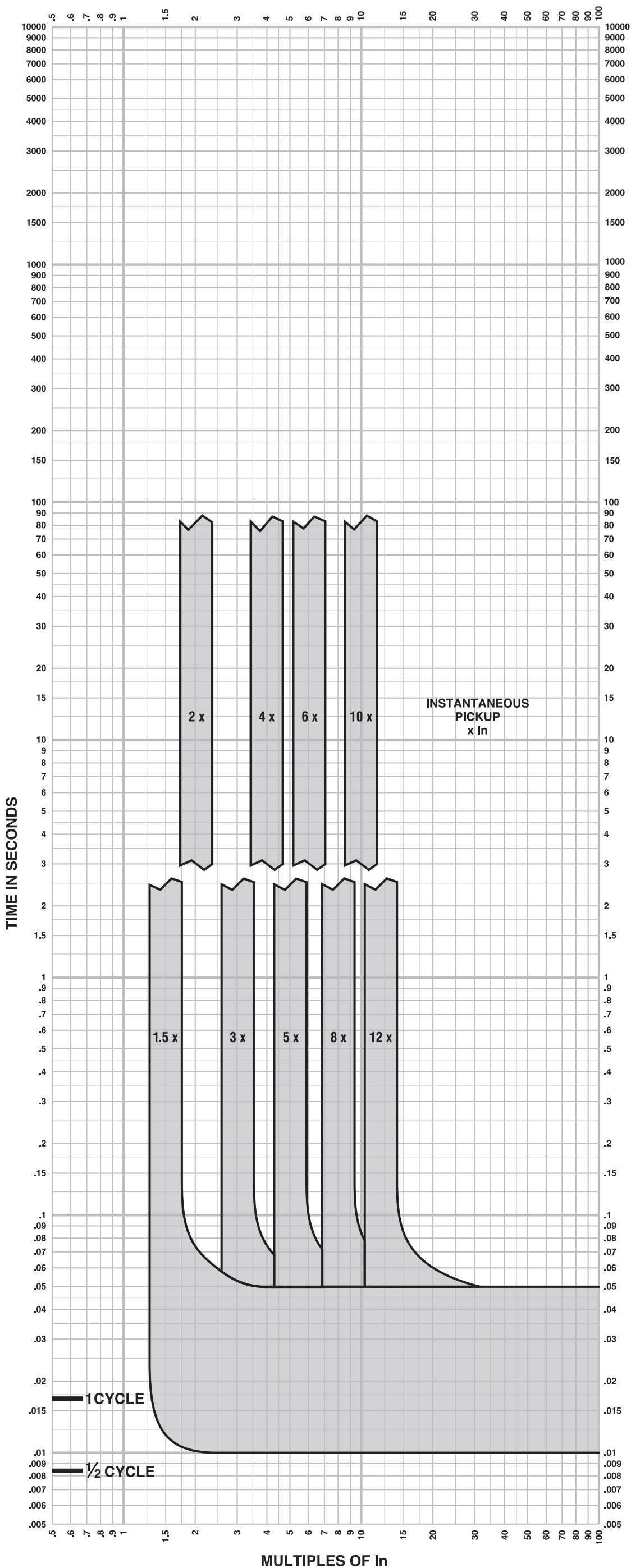

MICROLOGIC™ ELECTRONIC TRIP UNITS
Micrologic™ 3.3/3.3S/5.3A or E/6.3A or E
Instantaneous Trip Curve
400A L-Frame

The time-current curve information is to be used for application and coordination purposes only.

Notes:

1. There is a thermal-imaging effect that can act to shorten the long-time delay. The thermal imaging effect comes into play if a current above the long-time delay pickup value exists for a time and then is cleared by the tripping of a downstream device or the circuit breaker itself. A subsequent overload will cause the circuit breaker to trip in a shorter time than normal. The amount of time delay reduction is inverse to the amount of time that has elapsed since the previous overload. Approximately 20 minutes is required between overloads to completely reset thermal-imaging.
 2. Total clearing times shown include the response times of the trip unit, the circuit breaker opening, and the extinction of the current.
 3. I_n = Maximum dial setting of I_r .
 400A L-Frame: $I_n = 400A = \text{Max } I_r \text{ setting}$
- Curves apply from -35°C to $+70^\circ\text{C}$ (-31°F to $+158^\circ\text{F}$) ambient temperature.

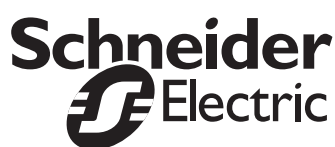

REL NO	LTR	NO	REVISION	OWN	CAD	APVD	DATE
ECO-156396	C	1	A052K399 WAS A048C269 IN BOM	DKS	MMJM	JAWALE	19OCT15
		2	CHANGED APPLICATION STATUS TO	-	-	-	-
			'ACCESSORY ONLY' FROM 'PRODUCTION ONLY'	-	-	-	-
			IN MATRIX.	DKS	MMJM	JAWALE	19OCT15

NOTES:
1. (NOTE REMOVED)

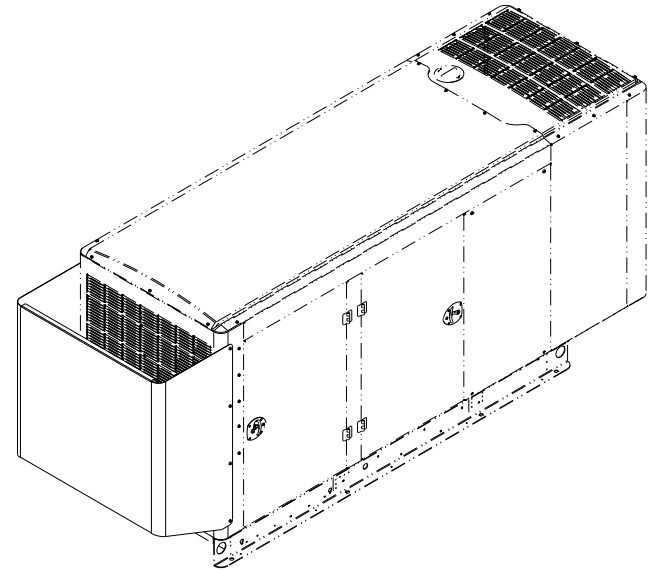
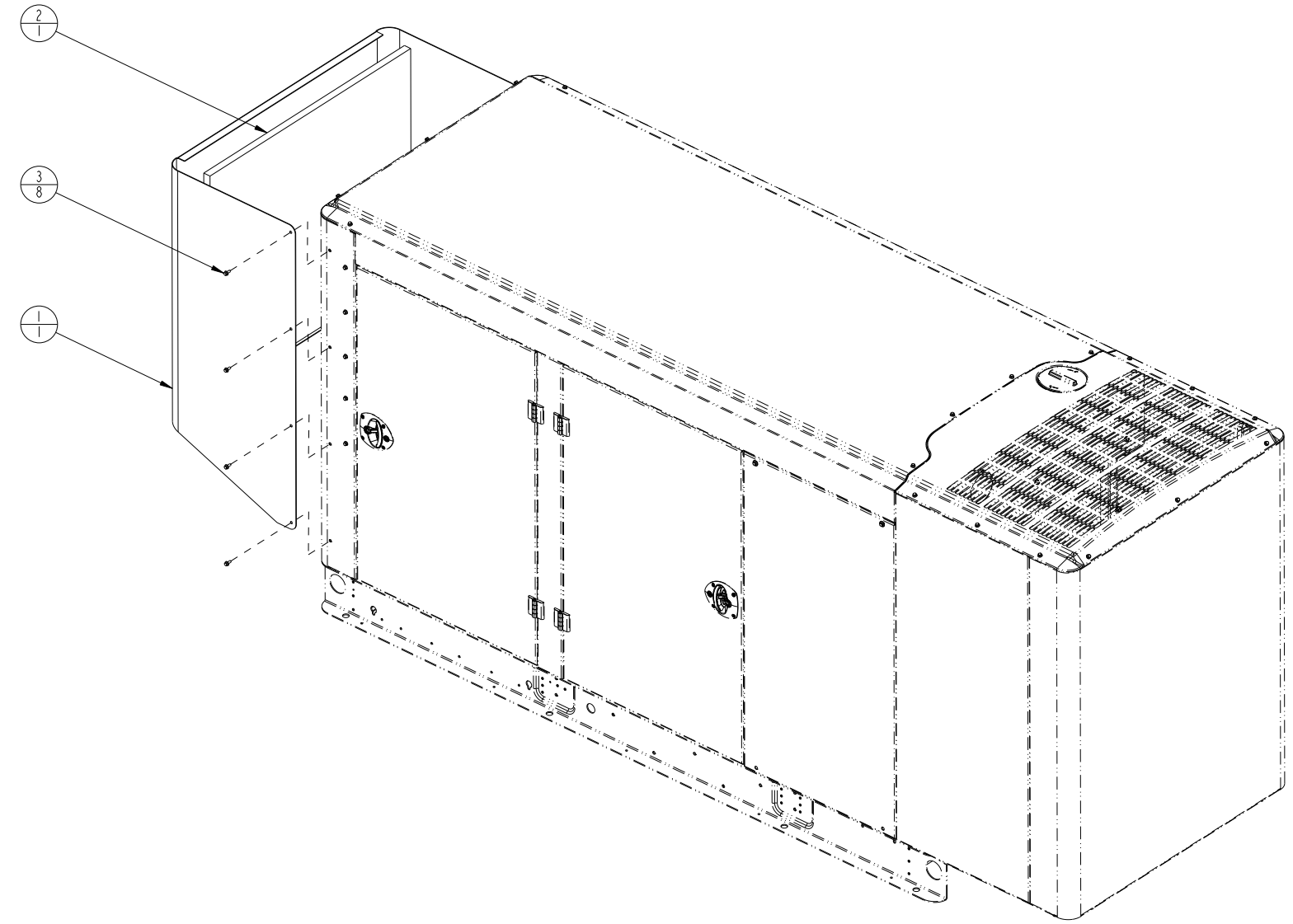

SCALE 1/16
3D VIEW

-THIS IS A CONTROLLED ITEM-
PER POLICY PROCEDURE PPG-1-01-01-116
TO MAINTAIN COMPLIANCE WITH REQUIREMENTS OF THE CODES, STANDARDS, OR AGENCIES LISTED BELOW
 CSA IN CE NEMA ABYC
 IEC OTHER

CHANGES, DEVIATIONS, OR SUBSTITUTIONS OF MATERIAL, PROCESS, OR PERFORMANCE CRITERIA MUST BE APPROVED BY THE FOLLOWING CONTROLLED ITEM APPROVER
RESPONSIBLE CIA ROLE: STATIONARY GENSET CIA
RESPONSIBLE CIA ROLE:

UNLESS OTHERWISE SPECIFIED, ALL DIMENSIONS ARE IN MILLIMETERS

CH	TOL	ROLE	0.00- 4.99	+0.15/-0.08
X	± 1		5.00- 9.99	+0.20/-0.10
.X	± 0.8		10.00-17.49	+0.25/-0.13
.XX	± 0.38		17.50-24.99	+0.30/-0.13

ANG TOL: ± 1.0° SCALE: 1/8

SIM 10	OWN C. GADE		CUMMINS POWER GENERATION	
DO NOT SCALE PRINT	CAD N. KASIBHOTLA		INSTALLATION, ENCLOSURE	
	APVD M. WICKMANN	SITE CODE	PGF	
	DATE 06MAY15	ARROW	D	A052M018
	FOR INTERPRETATION OF DIMENSIONS AND TOLERANCING, SEE ASME Y14.5M-1994	FIRST USED ON	SHEET 1 OF 1	REV C

Instruction Sheet

A052L825 (Issue 2)

8-2015

Installation Instructions for Enclosure Kits A052M016 and A052M018

1 Introduction

The information contained within is based on information available at the time of going to print. In line with Cummins Power Generation policy of continuous development and improvement, information may change at any time without notice. The users should therefore make sure that before commencing any work, they have the latest information available. The latest version of this instruction sheet is available on QuickServe Online (<https://qsol.cummins.com/info/index.html>).

2 Safety Precautions

2.1 General Safety Precautions

WARNING

Hot Pressurized Liquid

Contact with hot liquid can cause severe burns.

Do not open the pressure cap while the engine is running. Let the engine cool down before removing the cap. Turn the cap slowly and do not open it fully until the pressure has been relieved.

WARNING

Moving Parts

Moving parts can cause severe personal injury.

Use extreme caution around moving parts. All guards must be properly fastened to prevent unintended contact.

WARNING

Toxic Hazard

Used engine oils have been identified by some state and federal agencies to cause cancer or reproductive toxicity.

Do not ingest, breathe the fumes, or contact used oil when checking or changing engine oil. Wear protective gloves and face guard.

WARNING

Electrical Generating Equipment

Incorrect operation can cause severe personal injury or death.

Do not operate equipment when fatigued, or after consuming any alcohol or drug.

⚠ WARNING

Toxic Gases

Substances in exhaust gases have been identified by some state and federal agencies to cause cancer or reproductive toxicity.

Do not breathe in or come into contact with exhaust gases.

⚠ WARNING

Combustible Liquid

Ignition of combustible liquids is a fire or explosion hazard which can cause severe burns or death.

Do not store fuel, cleaners, oil, etc., near the generator set.

⚠ WARNING

High Noise Level

Generator sets in operation emit noise, which can cause hearing damage.

Wear appropriate ear protection at all times.

⚠ WARNING

Hot Surfaces

Contact with hot surfaces can cause severe burns.

Wear appropriate PPE when working on hot equipment and avoid physical contact with hot surfaces.

⚠ WARNING

Electrical Generating Equipment

Incorrect operation and maintenance can result in severe personal injury or death

Make sure that only suitably trained and experienced service personnel perform electrical and/or mechanical service.

⚠ WARNING

Toxic Hazard

Ethylene glycol, used as an engine coolant, is toxic to humans and animals.

Wear appropriate PPE. Clean up coolant spills and dispose of used coolant in accordance with local environmental regulations.

⚠ WARNING

Combustible Liquid

Ignition of combustible liquids is a fire or explosion hazard which can cause severe burns or death.

Do not use combustible liquids like ether.

⚠ WARNING

Automated Machinery

Accidental or remote starting of the generator set can cause severe personal injury or death.

Isolate all auxiliary supplies and use an insulated wrench to disconnect the starting battery cables (negative [-] first).

⚠ WARNING

Fire Hazard

Materials drawn into the generator set are a fire hazard. Fire can cause severe burns or death. Keep the generator set and the surrounding area clean and free from obstructions.

⚠ WARNING

Fire Hazard

Materials drawn into the generator set are a fire hazard. Fire can cause severe burns or death. Make sure the generator set is mounted in a manner to prevent combustible materials from accumulating under the unit.

⚠ WARNING

Fire Hazard

Accumulated grease and oil are a fire hazard. Fire can cause severe burns or death. Keep the generator set and the surrounding area clean and free from obstructions. Repair oil leaks promptly.

⚠ WARNING

Fire Hazard

Materials drawn into the generator set are a fire hazard. Fire can cause severe burns or death. Keep the generator set and the surrounding area clean and free from obstructions.

NOTICE

Keep multi-class ABC fire extinguishers handy. Class A fires involve ordinary combustible materials such as wood and cloth. Class B fires involve combustible and flammable liquid fuels and gaseous fuels. Class C fires involve live electrical equipment. (Refer to NFPA No. 10 in applicable region.)

NOTICE

Before performing maintenance and service procedures on enclosed generator sets, make sure the service access doors are secured open.

NOTICE

Stepping on the generator set can cause parts to bend or break, leading to electrical shorts, or to fuel, coolant, or exhaust leaks. Do not step on the generator set when entering or leaving the generator room.

2.2 Generator Set Safety Code

Before operating the generator set, read the manuals and become familiar with them and the equipment. Safe and efficient operation can be achieved only if the equipment is properly operated and maintained. Many accidents are caused by failure to follow fundamental rules and precautions.

⚠ WARNING

Electrical Generating Equipment

Incorrect operation and maintenance can result in severe personal injury or death.

Read and follow all Safety Precautions, Warnings, and Cautions throughout this manual and the documentation supplied with the generator set.

2.3 Electrical Shocks and Arc Flashes Can Cause Severe Personal Injury or Death

⚠ WARNING

Electric Shock Hazard

Voltages and currents present an electrical shock hazard that can cause severe burns or death.

Contact with exposed energized circuits with potentials of 50 Volts AC or 75 Volts DC or higher can cause electrical shock and electrical arc flash. Refer to standard NFPA 70E or equivalent safety standards in corresponding regions for details of the dangers involved and for the safety requirements.

Guidelines to follow when working on de-energized electrical systems:

- Use proper PPE. Do not wear jewelry and make sure that any conductive items are removed from pockets as these items can fall into equipment and the resulting short circuit can cause shock or burning. Refer to standard NFPA 70E for PPE standards.
- De-energize and lockout/tagout electrical systems prior to working on them. Lockout/Tagout is intended to prevent injury due to unexpected start-up of equipment or the release of stored energy.
- De-energize and lockout/tagout all circuits and devices before removing any protective shields or making any measurements on electrical equipment.
- Follow all applicable regional electrical and safety codes.

In summary:

- Do not tamper with or bypass interlocks unless you are authorized to do so.
- Understand and assess the risks - use proper PPE.
- Make sure that an accompanying person who can undertake a rescue is nearby.

3 Instruction

3.1 Installation of Enclosure Kits A052M016 and A052M018

This instruction sheet describes the installation of enclosure kits A052M016 and A052M018.

Read these installation instructions completely and become familiar with safety warnings, cautions and installation procedure before starting.

1. Wipe surfaces where insulation will be attached with a rag and water to remove physical debris. Let dry.
2. Remove the release liner from the insulation pieces and apply the insulation in the location shown in the figure below. Be sure to press down firmly on all areas of insulation to engage the pressure-sensitive adhesive.

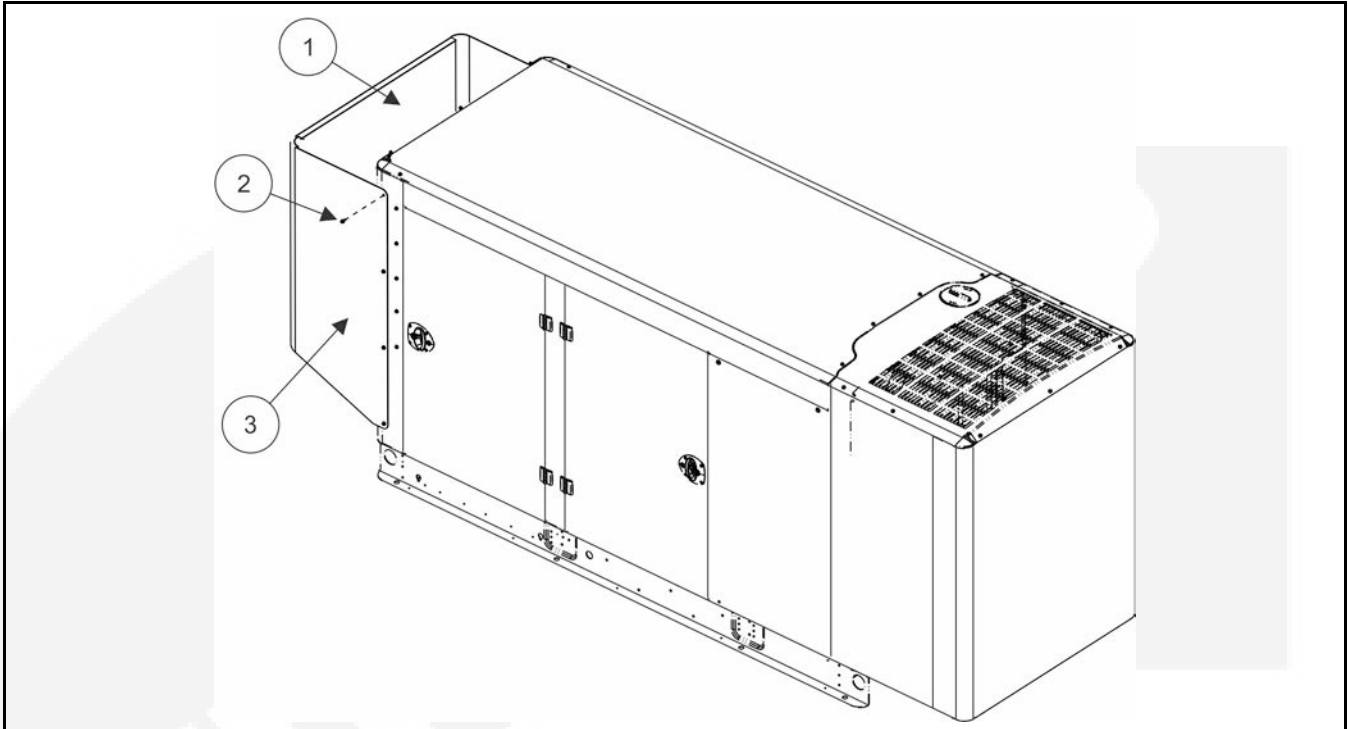

No.	Description	No.	Description
1	Panel Insulation	3	Inlet Duct
2	Hex Flange Head Screw		

FIGURE 1. ENCLOSURE KIT ATTACHED TO GENERATOR SET

3. Make sure there is no debris in the mounting holes.
4. Make sure the sloped end of the inlet duct is on the bottom, as shown in the figure above.
5. Bolt the inlet duct to the enclosed generator set.
6. Tighten the bolts. Torque to 4.4 - 5.9 ft-lb (6 - 8 Nm).



SECTION 4

Generator Drawings



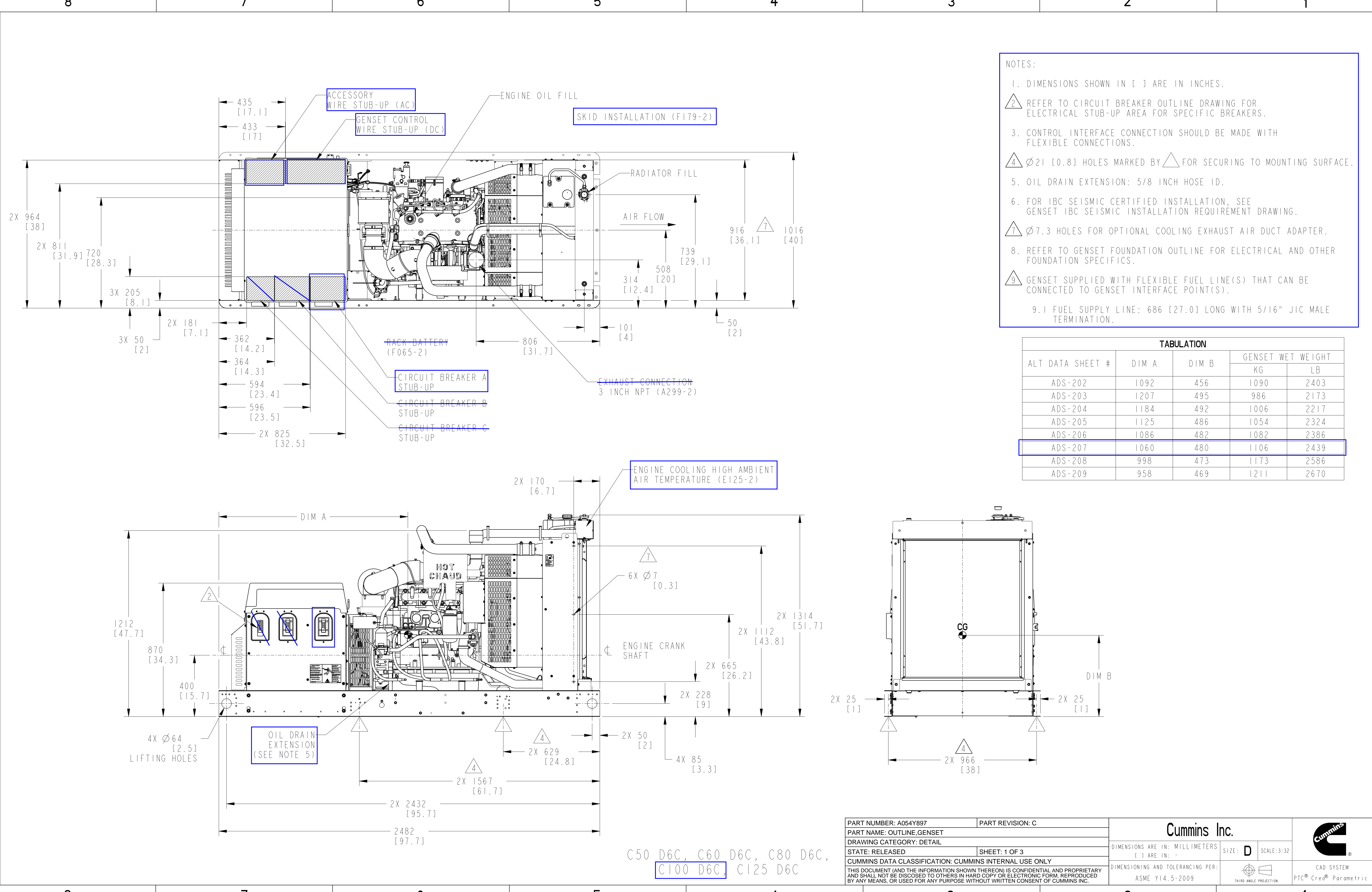

- NOTES:
1. DIMENSIONS SHOWN IN [] ARE IN INCHES.
 2. REFER TO CIRCUIT BREAKER OUTLINE DRAWING FOR ELECTRICAL STUB-UP AREA FOR SPECIFIC BREAKERS.
 3. CONTROL INTERFACE CONNECTION SHOULD BE MADE WITH FLEXIBLE CONNECTIONS.
 4. Ø21 [0.8] HOLES MARKED BY FOR SECURING TO MOUNTING SURFACE.
 5. OIL DRAIN EXTENSION: 5/8 INCH HOSE ID.
 6. FOR IBC SEISMIC CERTIFIED INSTALLATION, SEE GENSET IBC SEISMIC INSTALLATION REQUIREMENT DRAWING.
 7. Ø7.3 HOLES FOR OPTIONAL COOLING EXHAUST AIR DUCT ADAPTER.
 8. REFER TO GENSET FOUNDATION OUTLINE FOR ELECTRICAL AND OTHER FOUNDATION SPECIFICS.
 9. GENSET SUPPLIED WITH FLEXIBLE FUEL LINE(S) THAT CAN BE CONNECTED TO GENSET INTERFACE POINT(S).
 - 9.1 FUEL SUPPLY LINE: 686 [27.0] LONG WITH 5/16" JIC MALE TERMINATION.

ALT DATA SHEET #	DIM A	DIM B	GENSET WET WEIGHT	
			KG	LB
ADS-202	1092	456	1090	2403
ADS-203	1207	495	986	2173
ADS-204	1184	492	1006	2217
ADS-205	1125	486	1054	2324
ADS-206	1086	482	1082	2386
ADS-207	1060	480	1106	2439
ADS-208	998	473	1173	2586
ADS-209	958	469	1211	2670

PART NUMBER: A054Y897	PART REVISION: C	Cummins Inc.	
PART NAME: OUTLINE, GENSET			
DRAWING CATEGORY: DETAIL		DIMENSIONS ARE IN: MILLIMETERS	SIZE: D
STATE: RELEASED		[] ARE IN: -	SCALE: 3:32
CUMMINS DATA CLASSIFICATION: CUMMINS INTERNAL USE ONLY		DIMENSIONING AND TOLERANCING PER:	THIRD ANGLE PROJECTION
THIS DOCUMENT (AND THE INFORMATION SHOWN THEREON) IS CONFIDENTIAL AND PROPRIETARY AND SHALL NOT BE DISCLOSED TO OTHERS IN HARD COPY OR ELECTRONIC FORM, REPRODUCED BY ANY MEANS, OR USED FOR ANY PURPOSE WITHOUT WRITTEN CONSENT OF CUMMINS INC.		ASME Y14.5-2009	CAD SYSTEM PTC® Creo® Parametric

C50 D6C, C60 D6C, C80 D6C,
C100 D6C, C125 D6C

8 7 6 5 4 3 2 1

D
C
B
A

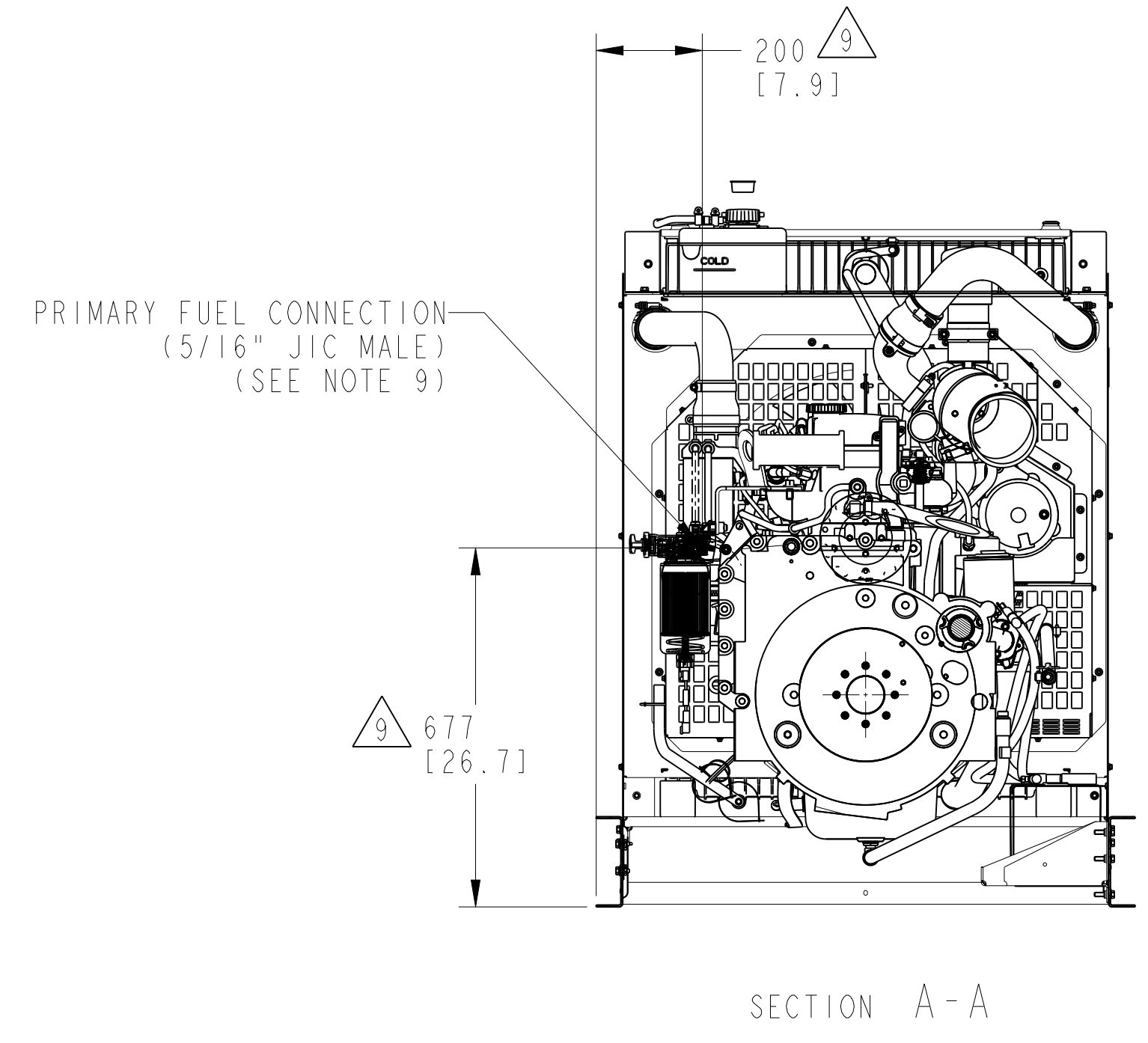
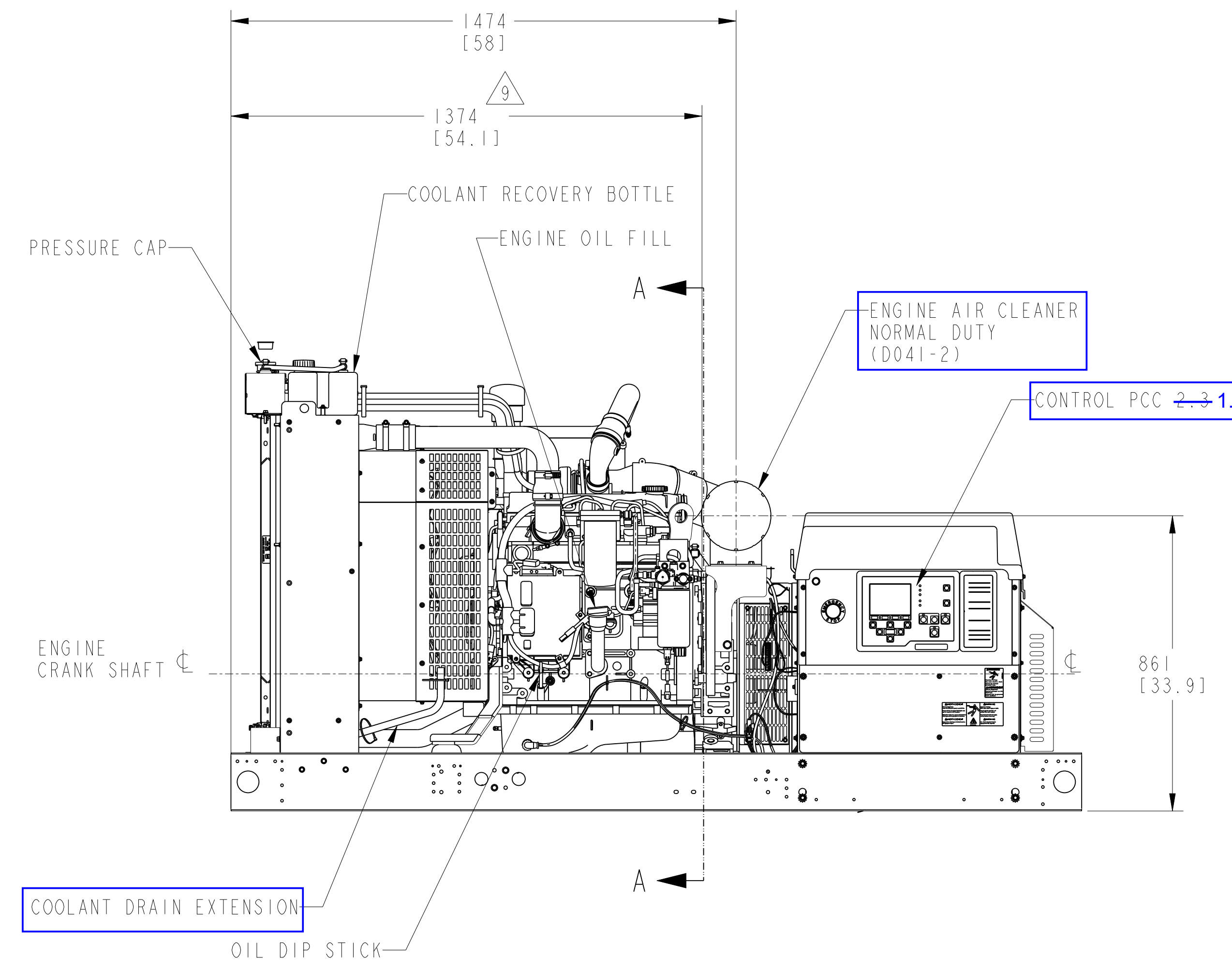

C50 D6C, C60 D6C, C80 D6C, C100 D6C, C125 D6C

PART NUMBER: A054Y897	PART REVISION: C	Cummins Inc.		
PART NAME: OUTLINE, GENSET				
DRAWING CATEGORY: DETAIL		DIMENSIONS ARE IN: MILLIMETERS	SIZE: D	SCALE: 3:32
STATE: RELEASED	SHEET: 2 OF 3	[] ARE IN: -		
CUMMINS DATA CLASSIFICATION: CUMMINS INTERNAL USE ONLY		DIMENSIONING AND TOLERANCING PER:		THIRD ANGLE PROJECTION
THIS DOCUMENT (AND THE INFORMATION SHOWN THEREON) IS CONFIDENTIAL AND PROPRIETARY AND SHALL NOT BE DISCLOSED TO OTHERS IN HARD COPY OR ELECTRONIC FORM. REPRODUCED BY ANY MEANS, OR USED FOR ANY PURPOSE WITHOUT WRITTEN CONSENT OF CUMMINS INC.		ASME Y14.5-2009		PTC® Creo® Parametric

8 7 6 5 4 3 2 1

8

7

6

5

4

3

2

1

NOTES:

1. DIMENSIONS SHOWN IN [] ARE IN INCHES.

D

D

C

C

B

B

A

A

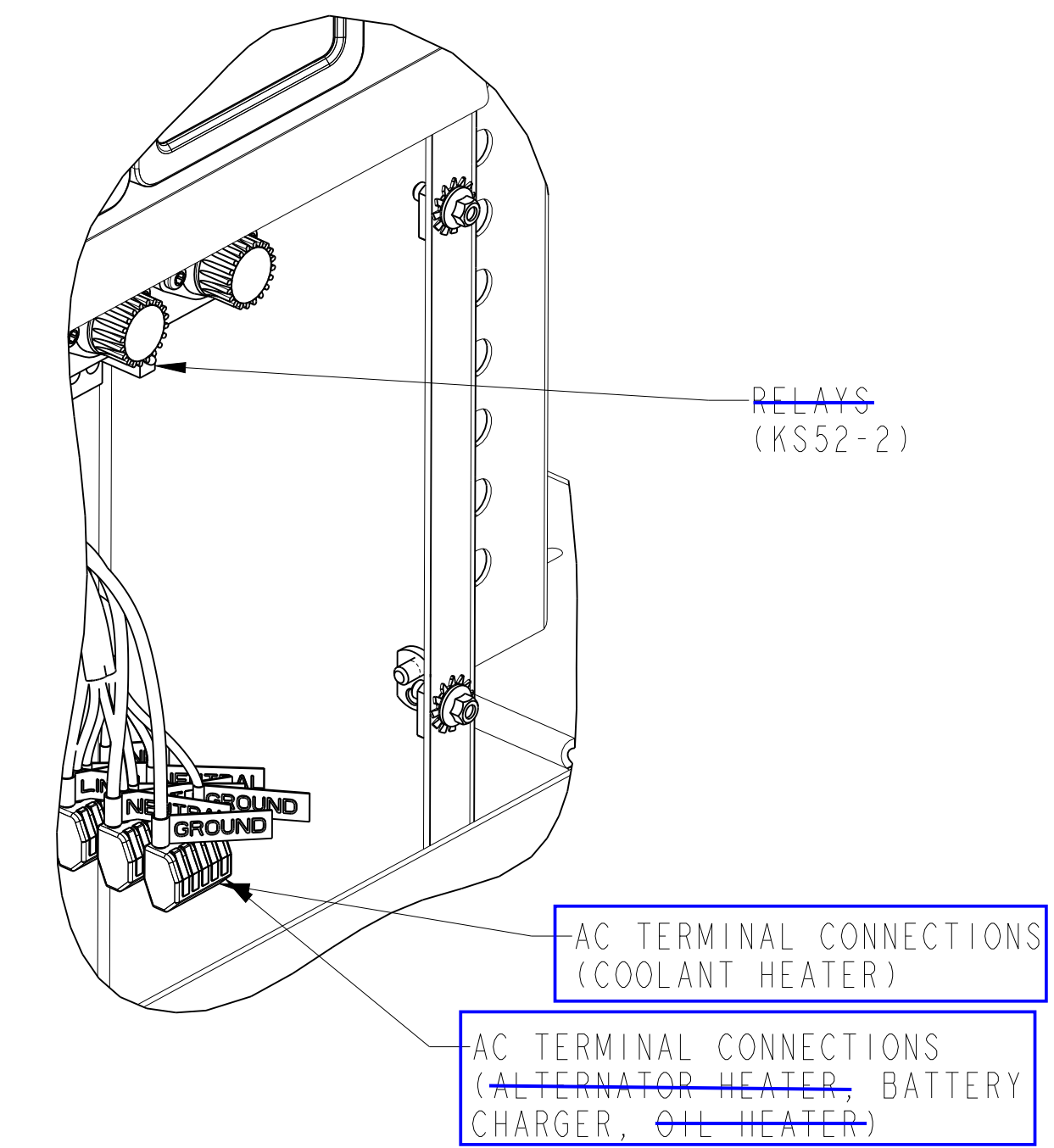
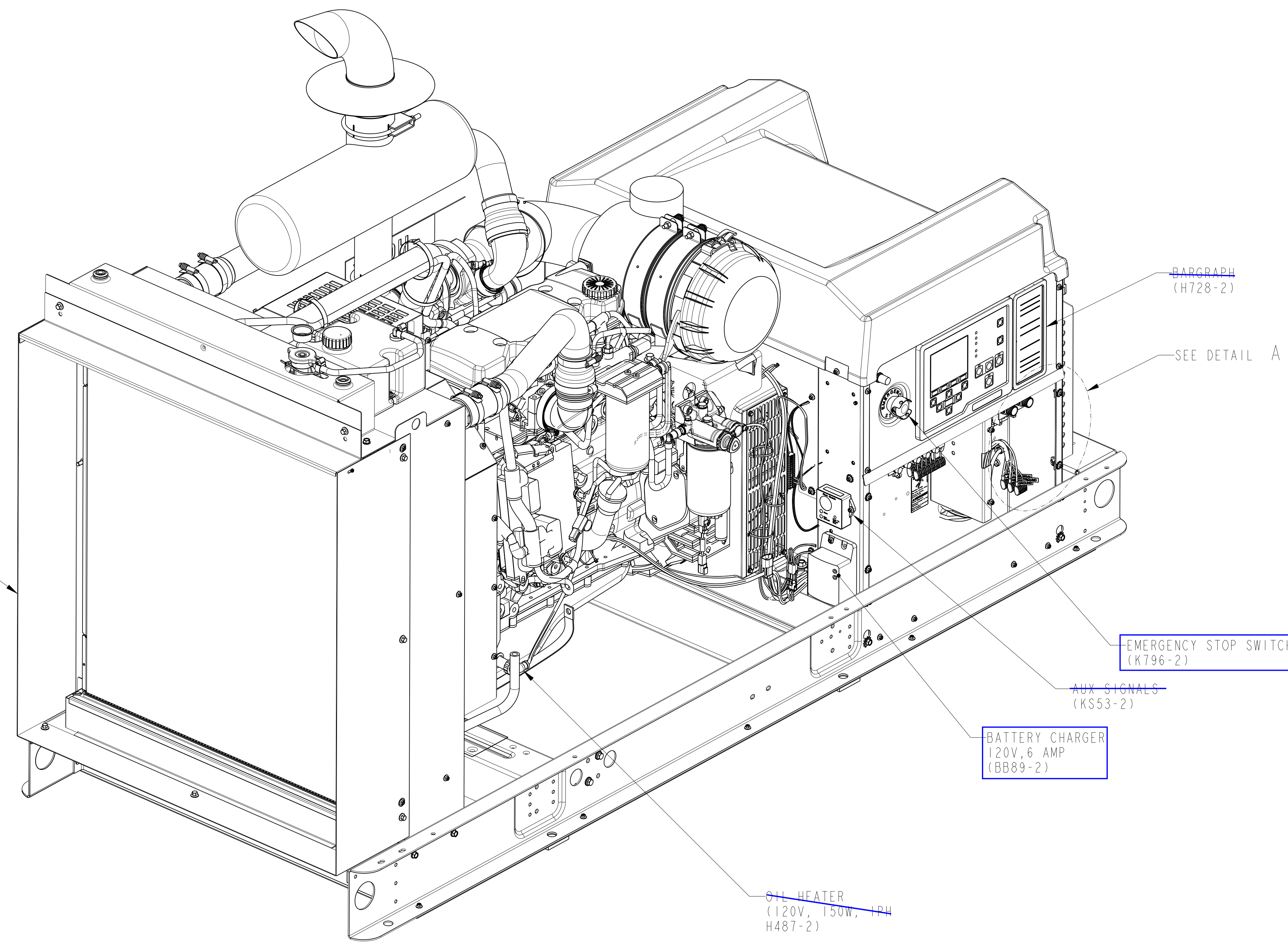

DETAIL A SCALE 1:2

C50 D6C, C60 D6C, C80 D6C, C100 D6C, C125 D6C

PART NUMBER: A054Y899	PART REVISION: E
PART NAME: OUTLINE, GENSET	
DRAWING CATEGORY: DETAIL	
STATE: RELEASED	SHEET: 1 OF 4
CUMMINS DATA CLASSIFICATION: CUMMINS INTERNAL USE ONLY	
THIS DOCUMENT (AND THE INFORMATION SHOWN THEREON) IS CONFIDENTIAL AND PROPRIETARY AND SHALL NOT BE DISCLOSED TO OTHERS IN HARD COPY OR ELECTRONIC FORM, REPRODUCED BY ANY MEANS, OR USED FOR ANY PURPOSE WITHOUT WRITTEN CONSENT OF CUMMINS INC.	

MODEL/PLATFORM: ARROW	THIS PART IS SIMILAR TO: NONE
Cummins Inc.	
DIMENSIONS ARE IN: MILLIMETERS [] ARE IN: -	SIZE: D SCALE: 3:16
DIMENSIONING AND TOLERANCING PER: ASME Y14.5-2009	THIRD ANGLE PROJECTION
CAD SYSTEM PTC® Creo® Parametric	

8

7

6

5

4

3

2

1

8

7

6

5

4

3

2

1

D

D

C

C

B

B

A

A

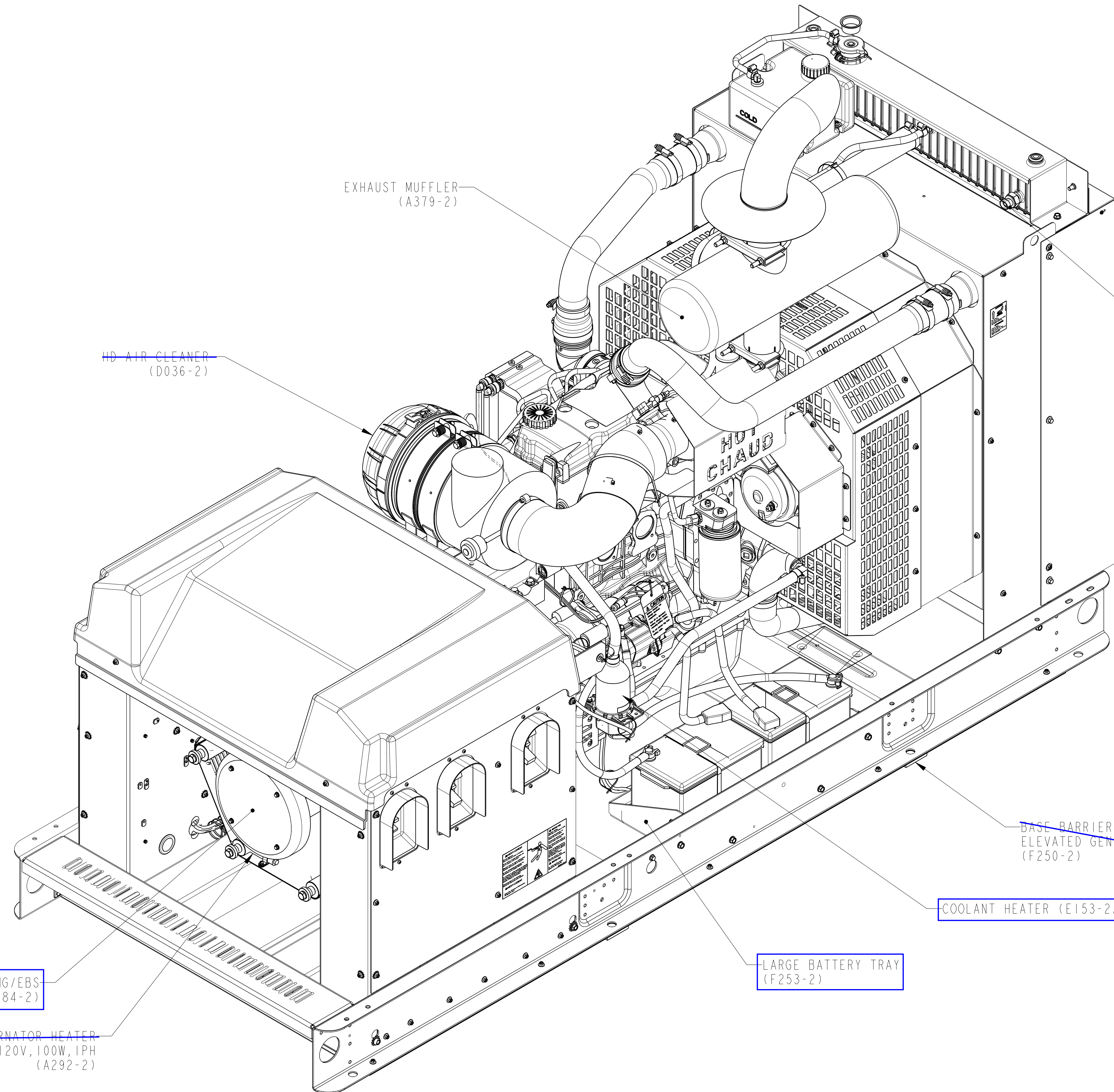

EXHAUST MUFFLER
(A379-2)

HD AIR CLEANER
(D036-2)

LOW COOLANT
SHUTDOWN/WARNING (SENSOR)
(H389-2/H527-2)

BASE BARRIER
ELEVATED GENSET
(F250-2)

COOLANT HEATER (E153-2/E154-2)

LARGE BATTERY TRAY
(F253-2)

EXCITER/REG-PMG/EBS
(B184-2)

ALTERNATOR HEATER
120V, 100W, 1PH
(A292-2)

C50 D6C, C60 D6C, C80 D6C,
C100 D6C C125 D6C

PART NUMBER: A054Y899	PART REVISION: E
PART NAME: OUTLINE, GENSET	
DRAWING CATEGORY: DETAIL	
STATE: RELEASED	SHEET: 2 OF 4
CUMMINS DATA CLASSIFICATION: CUMMINS INTERNAL USE ONLY	
THIS DOCUMENT (AND THE INFORMATION SHOWN THEREON) IS CONFIDENTIAL AND PROPRIETARY AND SHALL NOT BE DISCLOSED TO OTHERS IN HARD COPY OR ELECTRONIC FORM, REPRODUCED BY ANY MEANS, OR USED FOR ANY PURPOSE WITHOUT WRITTEN CONSENT OF CUMMINS INC.	

Cummins Inc.		
DIMENSIONS ARE IN: MILLIMETERS () ARE IN: -	SIZE: D SCALE: 3:16	
DIMENSIONING AND TOLERANCING PER: ASME Y14.5-2009		THIRD ANGLE PROJECTION
		CAD SYSTEM PTC® Creo® Parametric

8

7

6

5

4

3

2

1

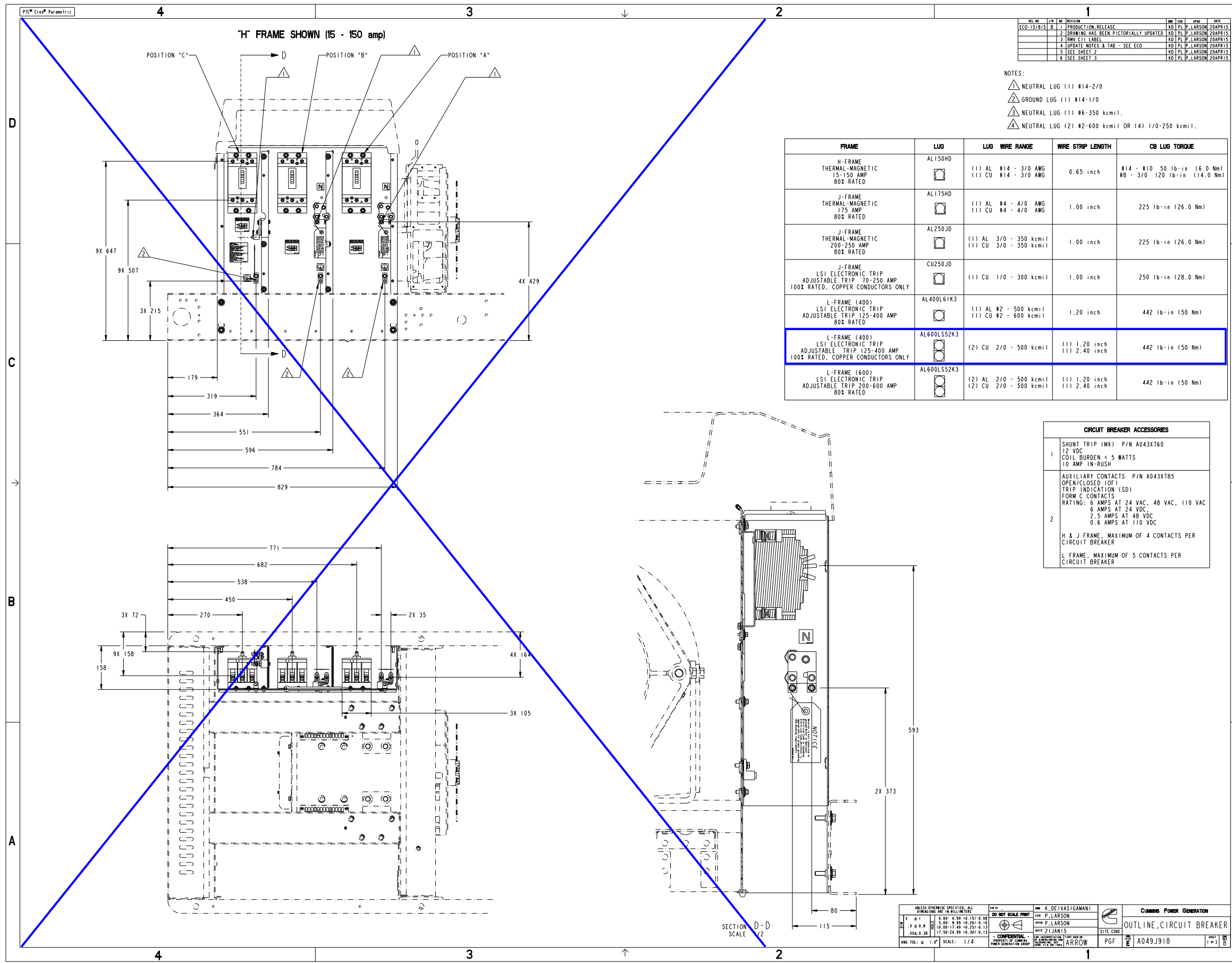

REV. NO.	DATE	DESCRIPTION	BY	CHKD.	APP'D.
ECO-151813	0	1 PRODUCTION RELEASE	RD FL P. LARSON	20APR15	
		2 DRAWING HAS BEEN PICTORIALY UPDATED	RD FL P. LARSON	20APR15	
		3 REV C11 LABEL	RD FL P. LARSON	20APR15	
		4 UPDATE NOTES & TAB - SEE ECO	RD FL P. LARSON	20APR15	
		5 SEE SHEET 2	RD FL P. LARSON	20APR15	
		6 SEE SHEET 3	RD FL P. LARSON	20APR15	

- NOTES:
- △ NEUTRAL LUG (1) #14-2/0
 - △ GROUND LUG (1) #14-1/0
 - △ NEUTRAL LUG (1) #6-350 kcmil.
 - △ NEUTRAL LUG (2) #2-600 kcmil OR (4) 1/0-250 kcmil.

FRAME	LUG	LUG WIRE RANGE	WIRE STRIP LENGTH	CB LUG TORQUE
H-FRAME THERMAL-MAGNETIC 15-150 AMP 80% RATED	AL150HD	(1) AL #14 - 3/0 AWG (1) CU #14 - 3/0 AWG	0.65 inch	#14 - #10 50 lb-in (6.0 Nm) #8 - 3/0 120 lb-in (14.0 Nm)
J-FRAME THERMAL-MAGNETIC 175 AMP 80% RATED	AL175HD	(1) AL #4 - 4/0 AWG (1) CU #4 - 4/0 AWG	1.00 inch	225 lb-in (26.0 Nm)
J-FRAME THERMAL-MAGNETIC 200-250 AMP 80% RATED	AL250JD	(1) AL 3/0 - 350 kcmil (1) CU 3/0 - 350 kcmil	1.00 inch	225 lb-in (26.0 Nm)
J-FRAME LSI ELECTRONIC TRIP ADJUSTABLE TRIP 70-250 AMP 100% RATED, COPPER CONDUCTORS ONLY	CU250JD	(1) CU 1/0 - 300 kcmil	1.00 inch	250 lb-in (28.0 Nm)
L-FRAME (400) LSI ELECTRONIC TRIP ADJUSTABLE TRIP 125-400 AMP 80% RATED	AL400L61K3	(1) AL #2 - 500 kcmil (1) CU #2 - 600 kcmil	1.20 inch	442 lb-in (50 Nm)
L-FRAME (400) LSI ELECTRONIC TRIP ADJUSTABLE TRIP 125-400 AMP 100% RATED, COPPER CONDUCTORS ONLY	AL600LS52K3	(2) CU 2/0 - 500 kcmil	(1) 1.20 inch (1) 2.40 inch	442 lb-in (50 Nm)
L-FRAME (600) LSI ELECTRONIC TRIP ADJUSTABLE TRIP 200-600 AMP 80% RATED	AL600LS52K3	(2) AL 2/0 - 500 kcmil (2) CU 2/0 - 500 kcmil	(1) 1.20 inch (1) 2.40 inch	442 lb-in (50 Nm)

CIRCUIT BREAKER ACCESSORIES	
1	SHUNT TRIP (MX) P/N A043X760 12 VDC COIL BURDEN < 5 WATTS 10 AMP 1N-RUSH
2	AUXILIARY CONTACTS P/N A043X785 OPEN/CLOSED (OF) TRIP INDICATION (SD) FORM C CONTACTS RATING: 6 AMPS AT 24 VAC, 48 VAC, 110 VAC 6 AMPS AT 24 VDC, 2.5 AMPS AT 48 VDC 0.6 AMPS AT 110 VDC

H & J FRAME, MAXIMUM OF 4 CONTACTS PER CIRCUIT BREAKER
L FRAME, MAXIMUM OF 5 CONTACTS PER CIRCUIT BREAKER

UNLESS OTHERWISE SPECIFIED, ALL DIMENSIONS ARE IN MILLIMETERS

DO NOT SCALE PRINT

ANG TOL: ± 1.0° SCALE: 1/4

DESIGNED BY: K. DEIVASIGAMANI
CHKD BY: P. LARSON
DATE: 21 JAN 15

PROPERTY OF CUMMINS POWER GENERATION GROUP

CUMMINS POWER GENERATION
OUTLINE, CIRCUIT BREAKER

PGF A049J918

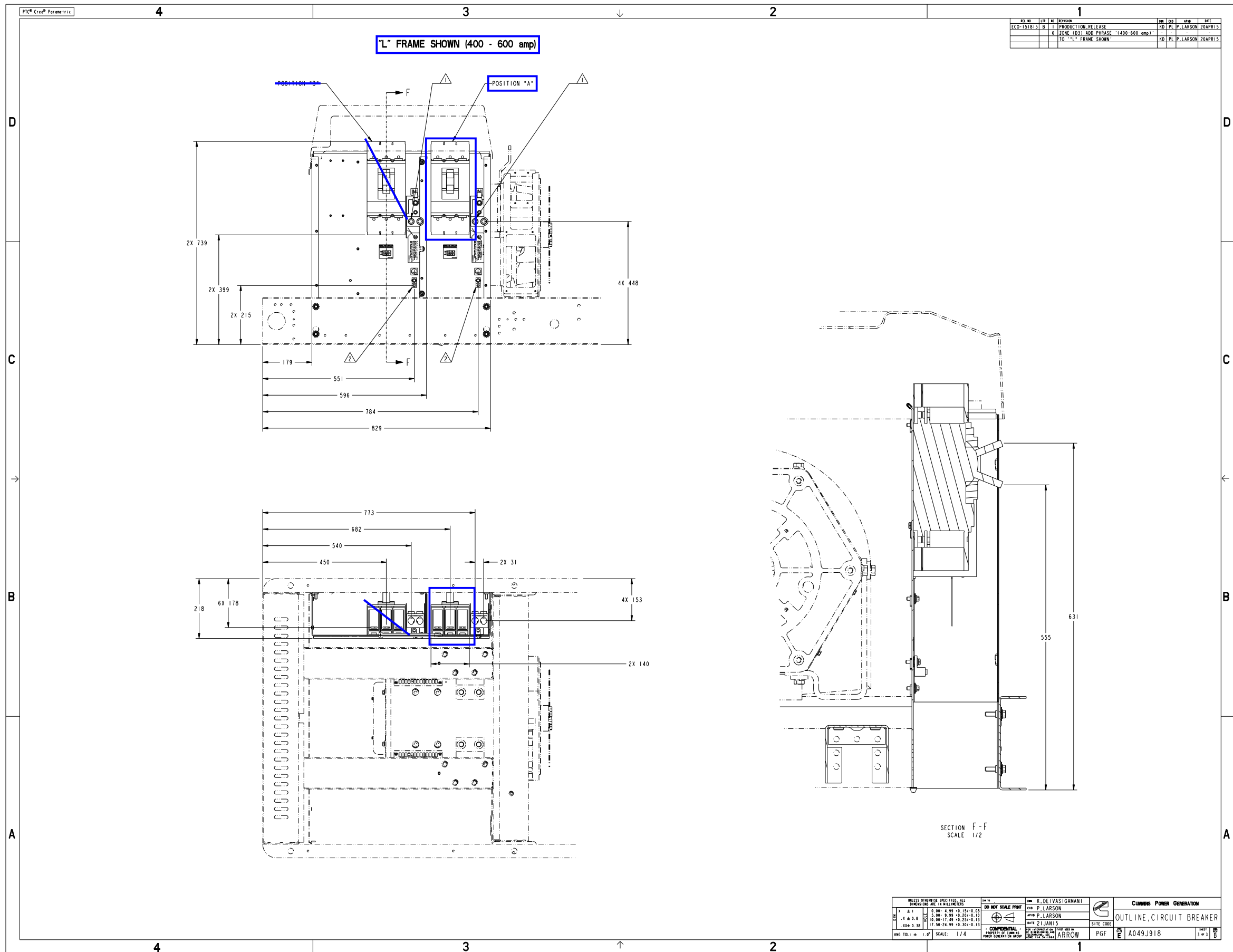

REV. NO.	DATE	DESCRIPTION	BY	CHKD.	DATE
ECO-1518/15	B	PRODUCTION RELEASE	RD FL P. LARSON	20APR15	
		6 ZONE (D3) ADD PHRASE "(400-600 amp)"	RD FL P. LARSON	20APR15	
		TO "L" FRAME SHOWN	RD FL P. LARSON	20APR15	

UNLESS OTHERWISE SPECIFIED, ALL DIMENSIONS ARE IN MILLIMETERS		DO NOT SCALE PRINT		K. DEIVASIGAMANI	
1 ± 0.13	2.00 - 4.99 ± 0.13 / 0.10	3 ± 0.25	5.00 - 9.99 ± 0.25 / 0.10	4 ± 0.50	10.00 - 24.99 ± 0.50 / 0.13
5 ± 0.38	25.00 - 49.99 ± 0.38 / 0.13	6 ± 0.75	50.00 - 99.99 ± 0.75 / 0.13	7 ± 1.50	100.00 - 249.99 ± 1.50 / 0.13
ANG TOL: ± 1.0°	SCALE: 1/4	PROPERTY OF CUMMINS POWER GENERATION GROUP		DATE: 21 JAN 15	
CUMMINS POWER GENERATION			OUTLINE, CIRCUIT BREAKER		
SITE CODE			PGF		
A049J918			A049J918		

REL NO	LTR	NO	REVISION	DRN	CAD	APVD	DATE
ECO-152551	A	1	PRODUCTION RELEASE	CG	NK	M. WICKMANN	14MAY15

NOTES:

- DIM [] IN INCHES
- WHEN THE HOUSING INSTALLED ON AN OPEN GENERATOR SET, THE TOTAL WEIGHT WILL INCREASE BY 131.5 KG (290 LBS). THIS INCLUDES THE MUFFLER.
- THE CENTER OF GRAVITY (CG) OF THE GENERATOR SET WHEN EQUIPPED WITH THIS HOUSING SHIFTS APPROXIMATELY 65mm (2.55 inch) TOWARDS THE AIR DISCHARGE END OF THE HOUSING AND 42MM (1.66 INCH) HIGHER FROM THE GROUND, COMPARED TO THE EQUIVALENT NON-HOUSED PRODUCT WITH THE F179 SKID. SEE HOUSING READY SKID BASE OUTLINE DRAWING FOR CG LOCATION OF NON HOUSED PRODUCT.

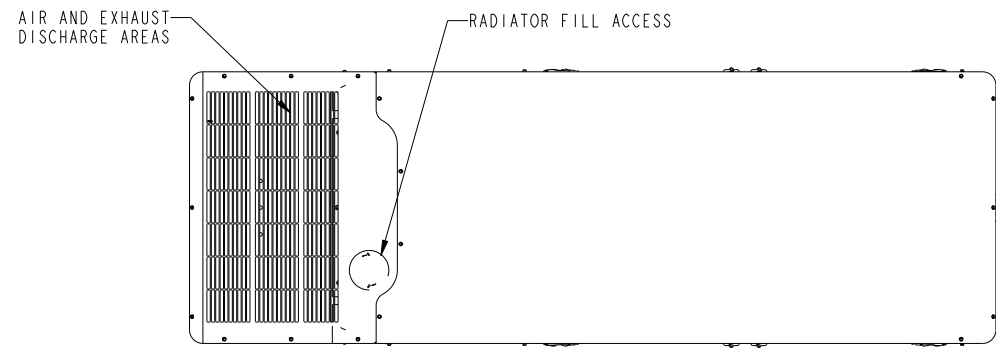
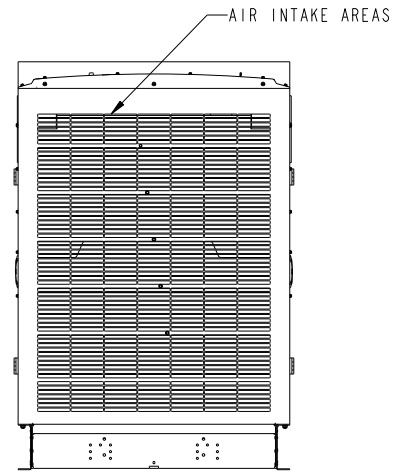

TOP VIEW

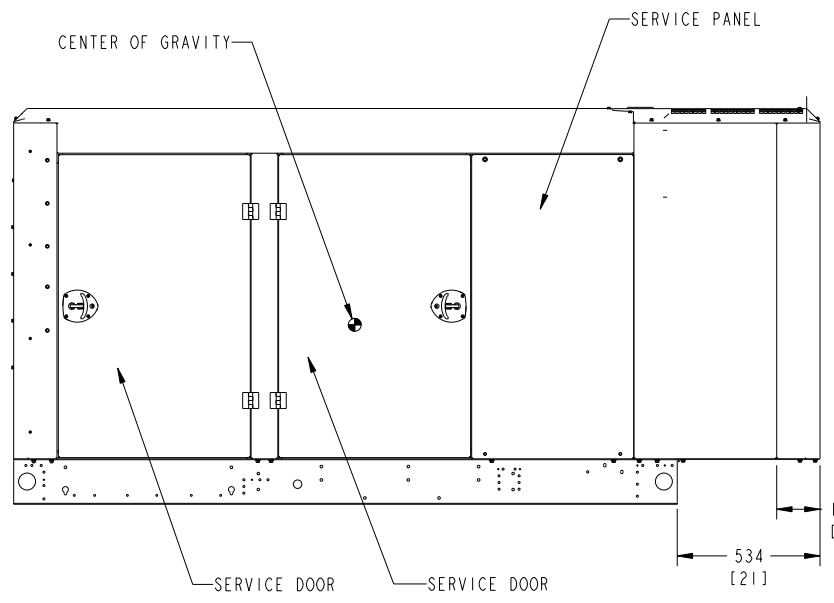

RIGHT SIDE VIEW

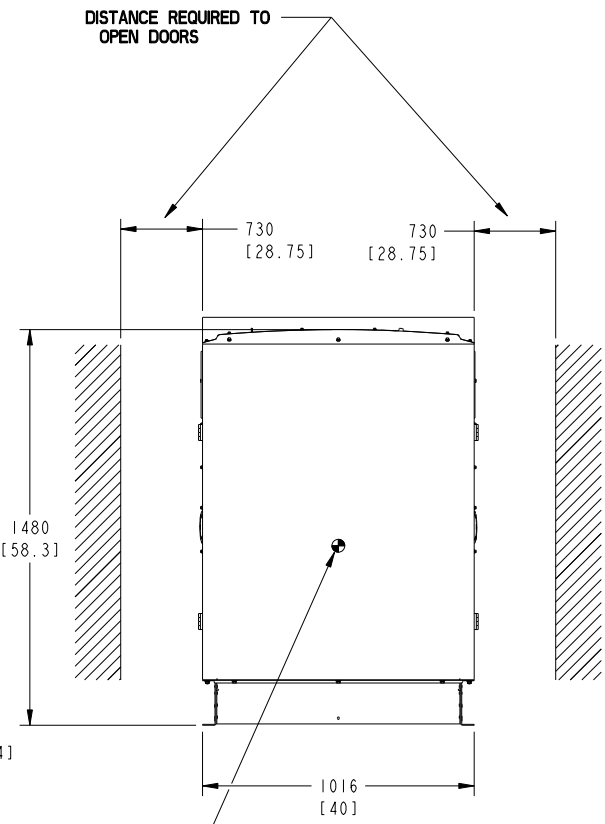

OUTLET VIEW

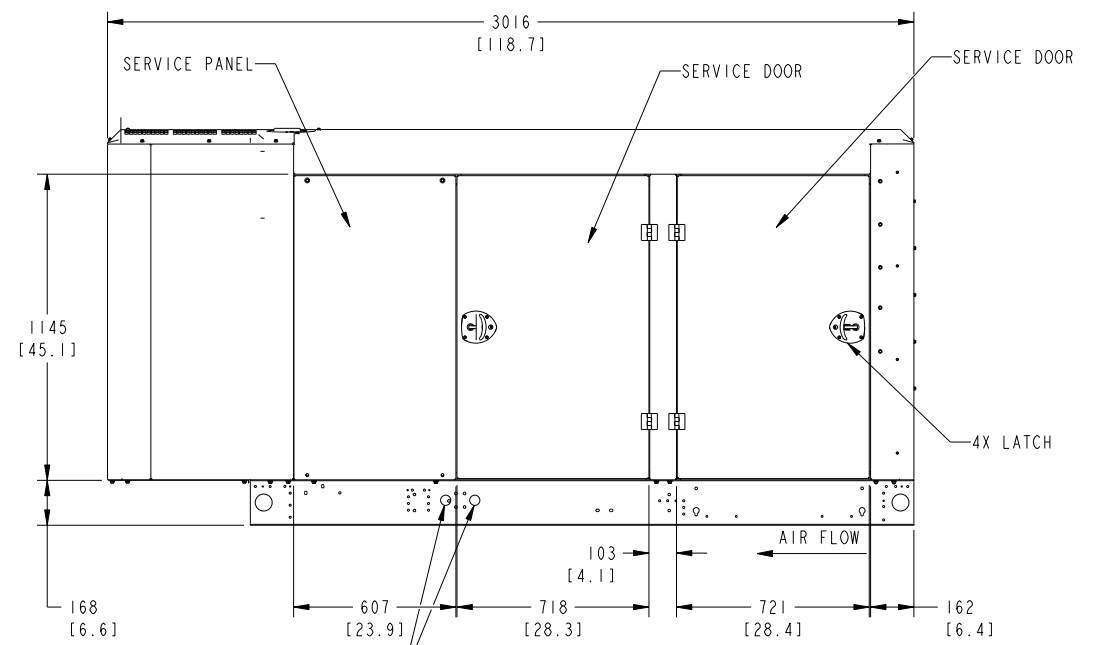

LEFT SIDE VIEW

F231-2 ENCLOSURE CONFIGURATION

UNLESS OTHERWISE SPECIFIED, ALL DIMENSIONS ARE IN MILLIMETERS		SIM 10 NONE	DRN C. GADE		CUMMINS POWER GENERATION	
DO NOT SCALE PRINT		CD N. KASIBHOTLA	OUTLINE, ENCLOSURE			
CH	X ± 1	0.00- 4.99 +0.15/-0.08	APVD M. WICKMANN	SITE CODE	REV D	A051P365
	.X ± 0.8	5.00- 9.99 +0.20/-0.10	DATE 14MAY15	PGF	SHEET 1 OF 2	REV A
	.XX ± 0.38	10.00-17.49 +0.25/-0.13		ARROW		
		17.50-24.99 +0.30/-0.13				
ANG TOL:	± 1.0°	SCALE: ~3/32	FOR INTERPRETATION OF DIMENSIONS AND TOLERANCING, SEE ASME Y14.5M-1994			

REL NO	LTR	NO	REVISION	DWN	CAD	APVD	DATE
ECO-152551	A	1	PRODUCTION RELEASE	CG	NK	M. WICKMANN	14MAY15

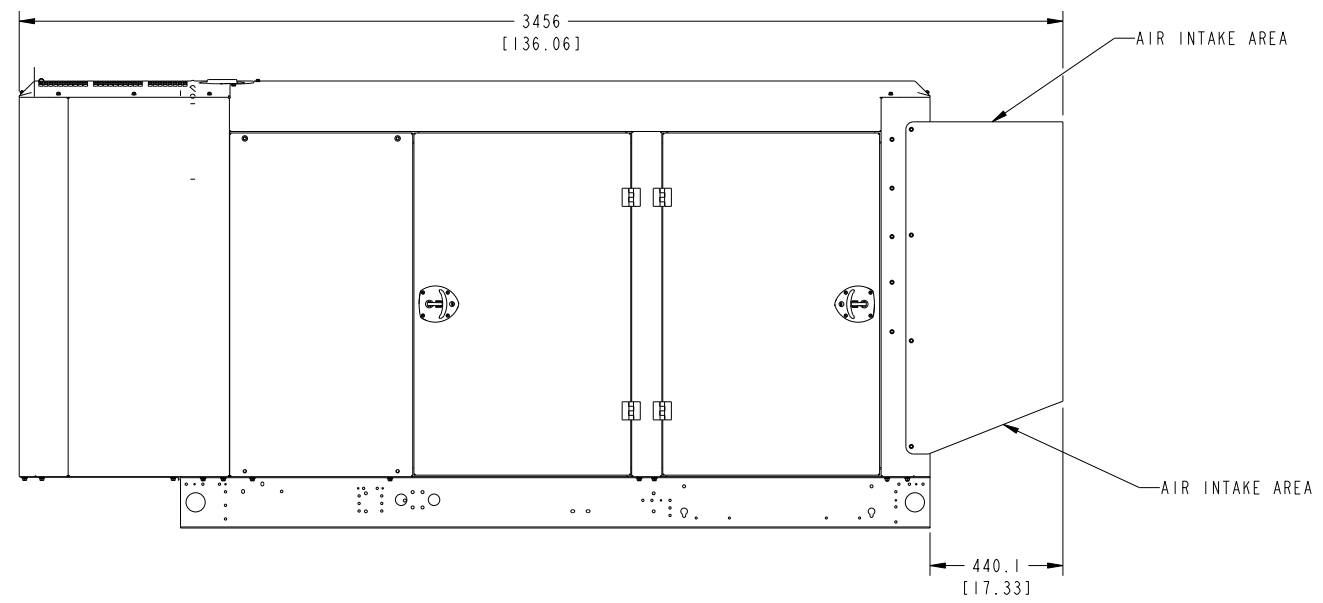
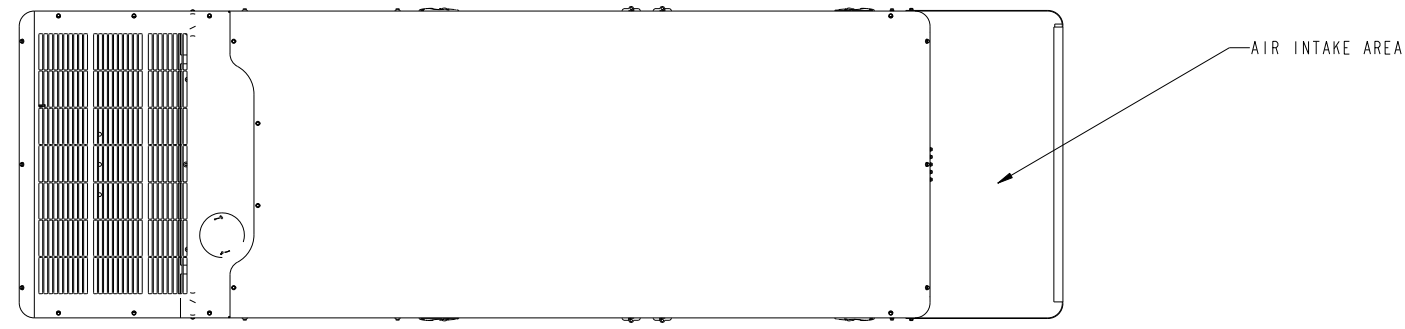

F217-2 ENCLOSURE CONFIGURATION
REFER TO PAGE 1 (F231-2 ENCLOSURE FOR
OTHER F217-2 ENCLOSURE DIMENSIONS.

UNLESS OTHERWISE SPECIFIED, ALL DIMENSIONS ARE IN MILLIMETERS		SIM 10 NONE	DWN C. GADE		CUMMINS POWER GENERATION																				
DO NOT SCALE PRINT			CAD N. KASIBHOTLA		OUTLINE, ENCLOSURE																				
<table border="1"> <tr> <th>DIM</th> <th>TOL</th> <th>ROLE</th> <th>VALUE</th> </tr> <tr> <td>X</td> <td>± 1</td> <td></td> <td>0.00- 4.99 +0.15/-0.08</td> </tr> <tr> <td>.X</td> <td>± 0.8</td> <td></td> <td>5.00- 9.99 +0.20/-0.10</td> </tr> <tr> <td>.XX</td> <td>± 0.38</td> <td></td> <td>10.00-17.49 +0.25/-0.13</td> </tr> <tr> <td></td> <td></td> <td></td> <td>17.50-24.99 +0.30/-0.13</td> </tr> </table>	DIM	TOL	ROLE	VALUE	X	± 1		0.00- 4.99 +0.15/-0.08	.X	± 0.8		5.00- 9.99 +0.20/-0.10	.XX	± 0.38		10.00-17.49 +0.25/-0.13				17.50-24.99 +0.30/-0.13	DATE 14MAY15	SITE CODE			
DIM	TOL	ROLE	VALUE																						
X	± 1		0.00- 4.99 +0.15/-0.08																						
.X	± 0.8		5.00- 9.99 +0.20/-0.10																						
.XX	± 0.38		10.00-17.49 +0.25/-0.13																						
			17.50-24.99 +0.30/-0.13																						
ANG TOL: ± 1.0°	SCALE: ~3/32	<p>CONFIDENTIAL</p> <p>FOR INTERPRETATION OF DIMENSIONS AND TOLERANCING, SEE ASME Y14.5M-1994</p>	<p>PROPERTY OF CUMMINS POWER GENERATION GROUP</p>	<p>FIRST USED ON ARROW</p>	PGF	<p>SHEET 2 OF 2</p> <p>REV A</p>																			
					<p>PGF</p>	<p>Part Name: A051P365</p>																			

REV NO	REV	NO	REVISION	REV	NO	APPD	DATE
ECO-174944	C	1	ZONE D-2: 4" WAS 3"	C	JF	M W	23 JAN 18
		2	ZONE C-2: 4" WAS 3"	C	JF	M W	23 JAN 18

- NOTES:
- TANKS ARE UL142 LISTED. SECONDARY CONTAINMENT FUEL TANK. REFER TO TANK LABELS AND LOCAL CODE TO DETERMINE VENTING REQUIREMENTS FOR BOTH COMPARTMENTS.
 - SUBBASE FUEL TANK MOUNTING. EXCESSIVE TWISTING OF THE FUEL TANK MAY RESULT IN STRUCTURAL FAILURE OF THE TANK. TO ENSURE THE INSTALLATION DOES NOT EXCESSIVELY TWIST THE FUEL TANK, THE FOLLOWING PROCEDURE MUST BE OBSERVED:
 - REFER TO APPLICATION MANUAL T030 FOR GENERAL SET MOUNTING GUIDELINES.
 - AFTER PLACING SET ON FOUNDATION, VERIFY ALL FOUR MOUNTING PADS CONTACT FOUNDATION.
 - THERE ARE SHIMS ATTACHED TO EACH FUEL TANK. THESE ARE INTENDED TO FILL ANY GAP BETWEEN THE MOUNTING PADS AND FOUNDATION.
 - INSERT THE MAXIMUM HEIGHT STACK OF SHIMS THAT WILL SLIDE INTO THE GAP.
 - TIGHTEN TANK HOLD DOWN MOUNTING FASTENERS.
 - INDICATES PIPE SIZE OF FEATURE OR OPTION INDICATED.
 - DIMENSIONS IN [] ARE IN INCHES.
 - FOR IBC SEISMIC CERTIFIED INSTALLATIONS, SEE GENSET IBC SEISMIC INSTALLATION REQUIREMENTS DRAWING.
 - FUEL TANK HAS A FLANGE THICKNESS OF UP TO 10 mm [0.394 in], ALLOW EXTRA LENGTH ON HARDWARE FOR UNEVENNESS OF MOUNTING SURFACE.
 - FUEL TANK PERIMETER IS SHOWN. FOUNDATION SHOULD BE EXTENDED BEYOND THIS PERIMETER. SEE (T030) APPLICATION MANUAL - (SEE SHEET 3).
 - INSTALLATION & REMOVAL LIFTING AND SERVICE ACCESS CLEARANCE (SUGGESTED MINIMUM) - (SEE SHEET 3).
 - REMOVABLE STUB-UP ACCESS PANEL.
 - MAINTAIN MIN 51 mm [2 in] CLEARANCE ABOVE E-VENT.
 - WEIGHT AND CENTER OF GRAVITY INFORMATION IS ESTIMATED AND CHANGES WITH TANK FEATURE INSTALLATION.

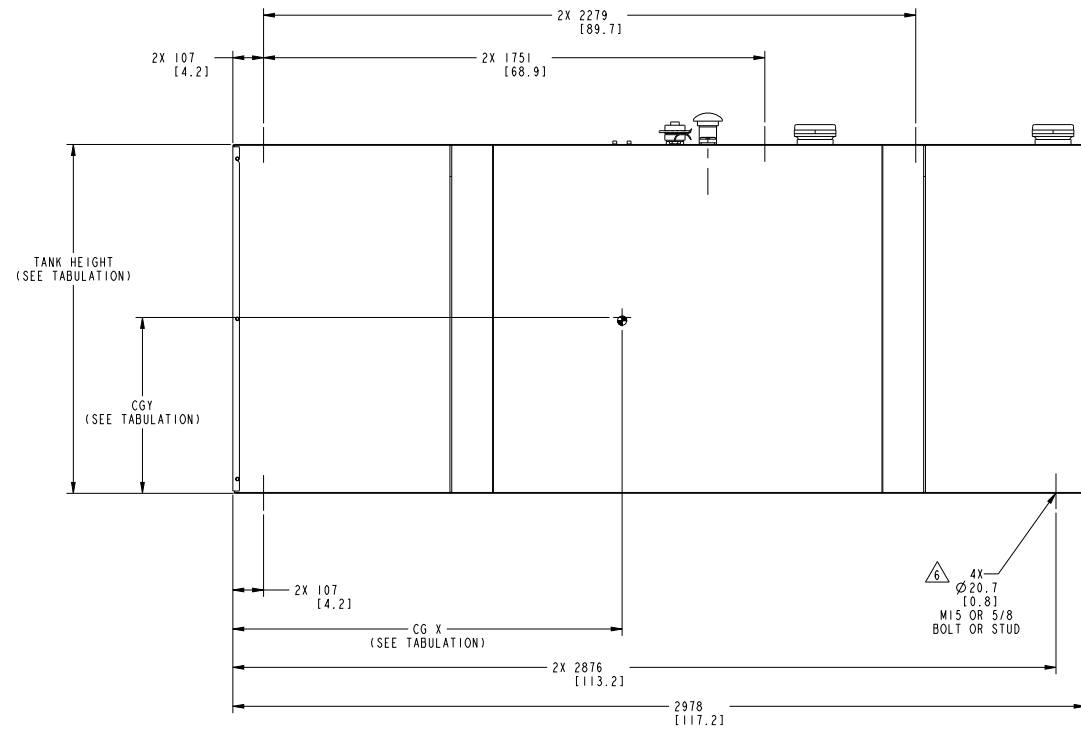
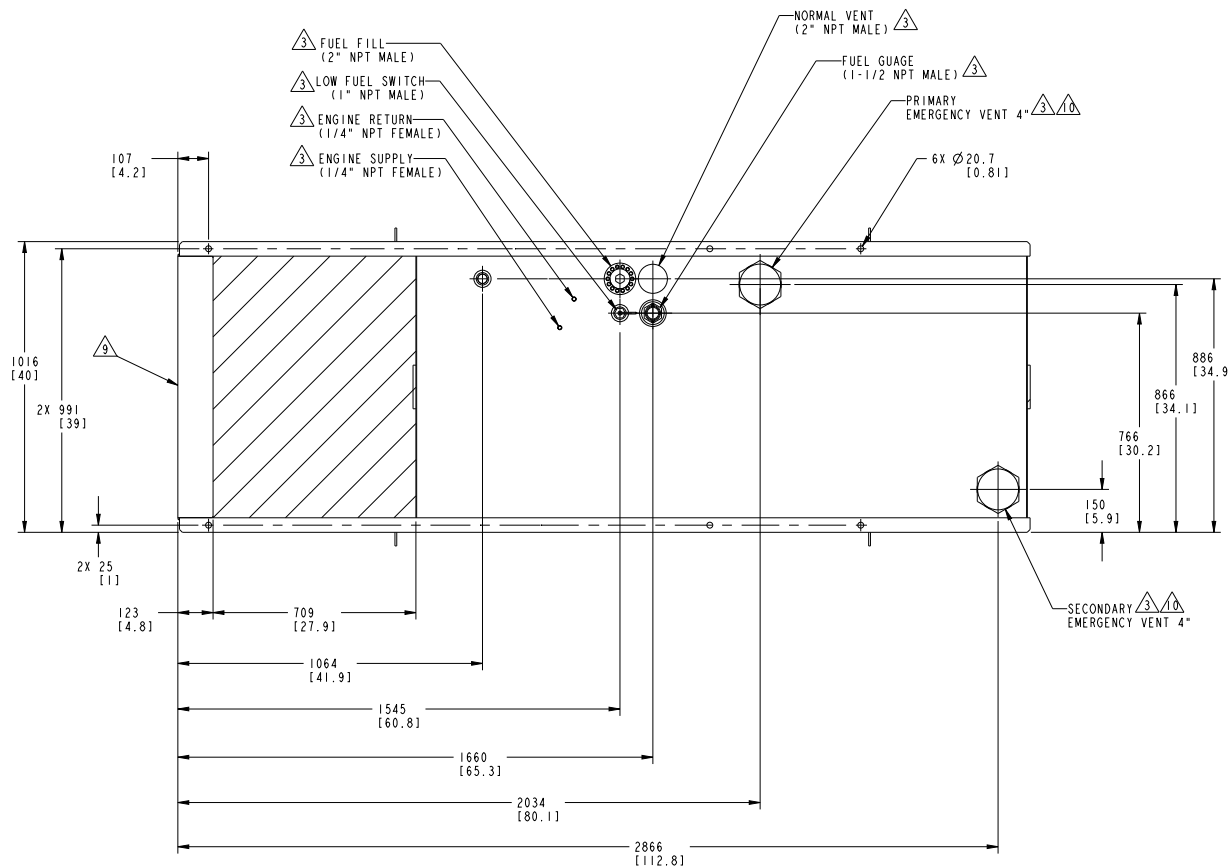

PART NUMBER IDENTIFICATION		
GENSET MODEL	TANK FEATURE CODE/RUN TIME	
C319-2	C319-2	C320-2
APPLICATION	24 HR	48 HR
C50 D6C	A053H409	A053H409
C60 D6C	A053H409	A053H411
C80 D6C	A053H409	A053H411
C100 D6C	A053H409	A053H412
C125 D6C	A053H409	A053H412

TABULATION									
TANK NUMBER	TANK HEIGHT	TANK VOLUME-LITER [GAL]		WEIGHT kg [lb]		CG_X		CG_Y	
		TOTAL (EST)	USABLE	MIN	MAX	MIN	MAX	MIN	MAX
A053H409	635 [25]	985 [260]	978 [258]	367 [809]	1199 [2641]	1736 [68]	1852 [73]	299 [11.8]	312 [12.3]
A053H411	838 [33]	1338 [353]	1327 [350]	439 [966]	1567 [3451]	1736 [68]	1852 [73]	398 [15.7]	413 [16.3]
A053H412	1219 [48]	1994 [526]	1971 [520]	668 [1471]	2344 [5163]	1736 [68]	1852 [73]	584 [23.0]	602 [23.7]

UNLESS OTHERWISE SPECIFIED, ALL DIMENSIONS ARE IN MILLIMETERS	DO NOT SCALE PRINT	APP'D D HOFMEISTER	DATE 01 FEB 18	GENSET MODEL	CUMMINS POWER GENERATION
± 0.13	± 0.13	CAD D HOFMEISTER	DATE 01 FEB 18	APPLICATION	OUTLINE, TANK
± 0.25	± 0.25	APP'D M JAWALE	DATE 01 FEB 18	SITE CODE	BASIC
± 0.38	± 0.38	DATE 01 FEB 18	DATE 01 FEB 18	PGF	A054T898
ANG TOL	SCALE	DATE 01 FEB 18	DATE 01 FEB 18	PGF	A054T898
± 1.0°	1:8	DATE 01 FEB 18	DATE 01 FEB 18	PGF	A054T898

REV NO	REV	NO	REVISION	NO	CHK	APPD	DATE
ECO-174944	C	1	-----	C.JF	M	M WINGFIELD	23 JAN 18

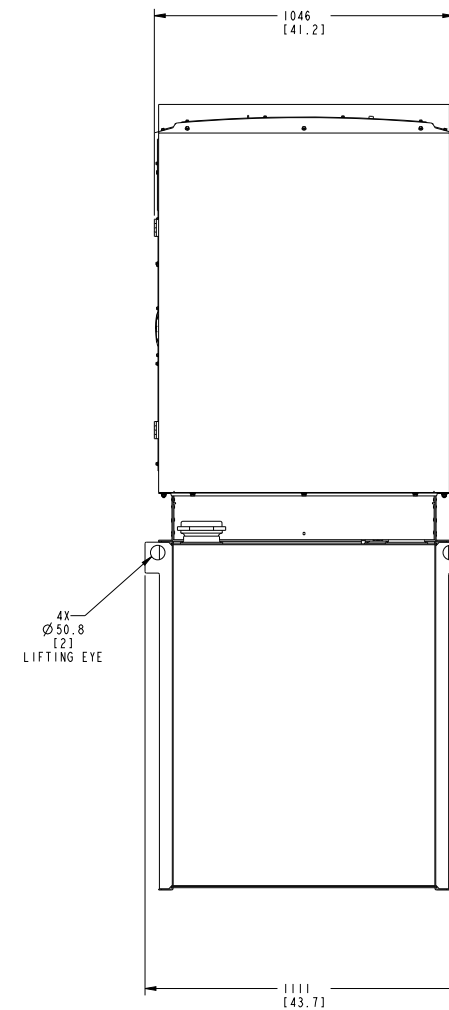
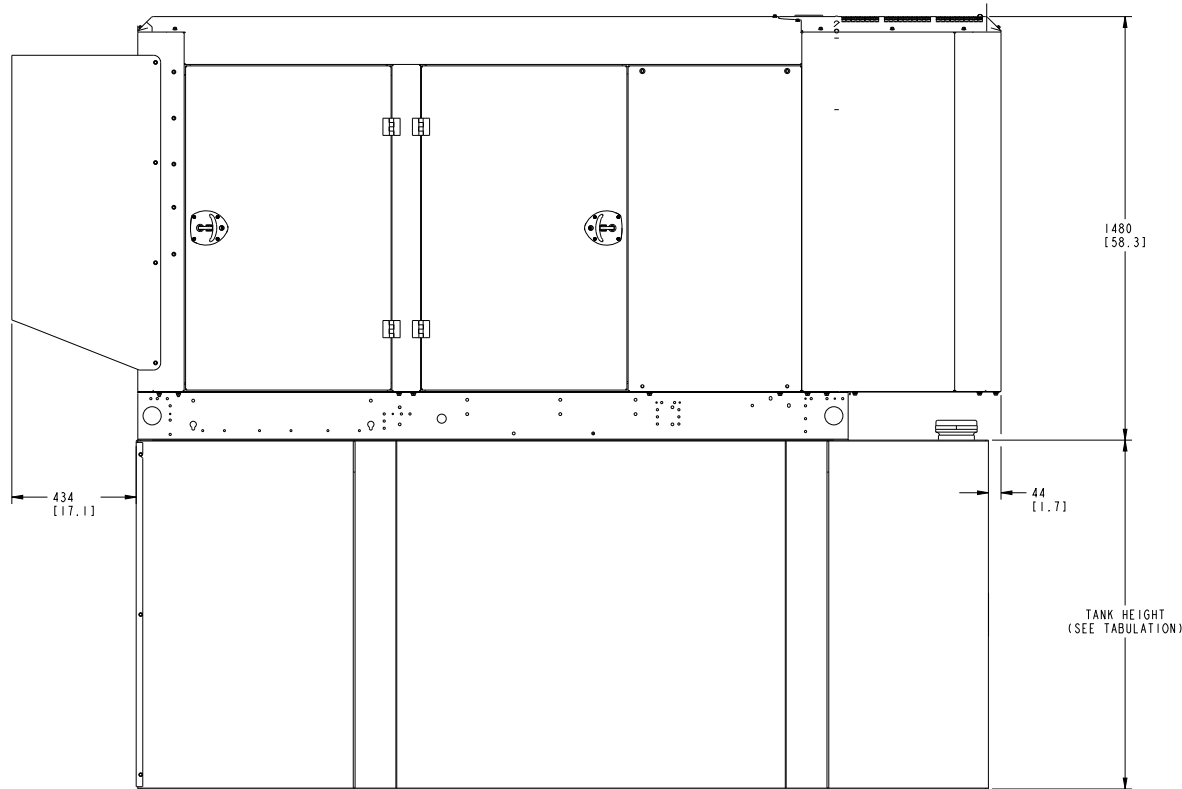
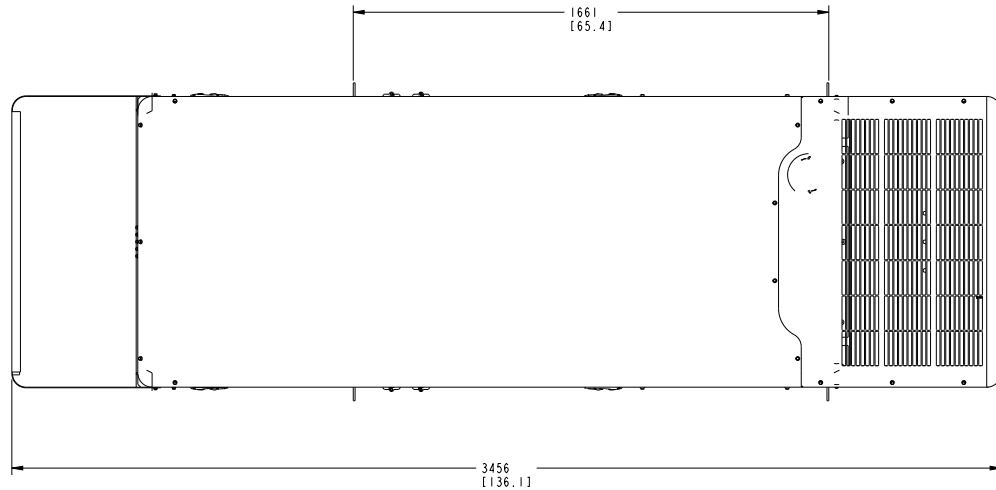

UNLESS OTHERWISE SPECIFIED, ALL DIMENSIONS ARE IN MILLIMETERS		DO NOT SCALE PRINT	APP'D D HOFMEISTER	CUMMINS POWER GENERATION OUTLINE, TANK BASIC
DIM X ± 1 -0 ± 0.8 X < 0.38	0.00 - 4.99 +0.15/-0.00 5.00 - 9.99 +0.20/-0.13 10.00 - 17.49 +0.25/-0.13 17.50 - 24.99 +0.30/-0.13		APP'D M JAWALE DATE 01 FEB 18	
ANG TOL ± 1.0°	SCALE 1:8	THIS DOCUMENT AND ALL INFORMATION CONTAINED HEREIN IS UNCLASSIFIED EXCEPT WHERE SHOWN OTHERWISE AND IS TO BE RELEASED TO THE PUBLIC BY THE NATIONAL ARCHIVES AND RECORDS ADMINISTRATION AT THE END OF THE LEGAL RETENTION PERIOD.	SITE CODE PGF E	A054T898 2 of 3

REV NO	REV	NO	REVISION	NO	CHK	APPD	DATE
ECO-174944	C	1	-----	C.JF	MW	M WINGFIELD	23 JAN 18

D

D

C

C

B

B

A

A

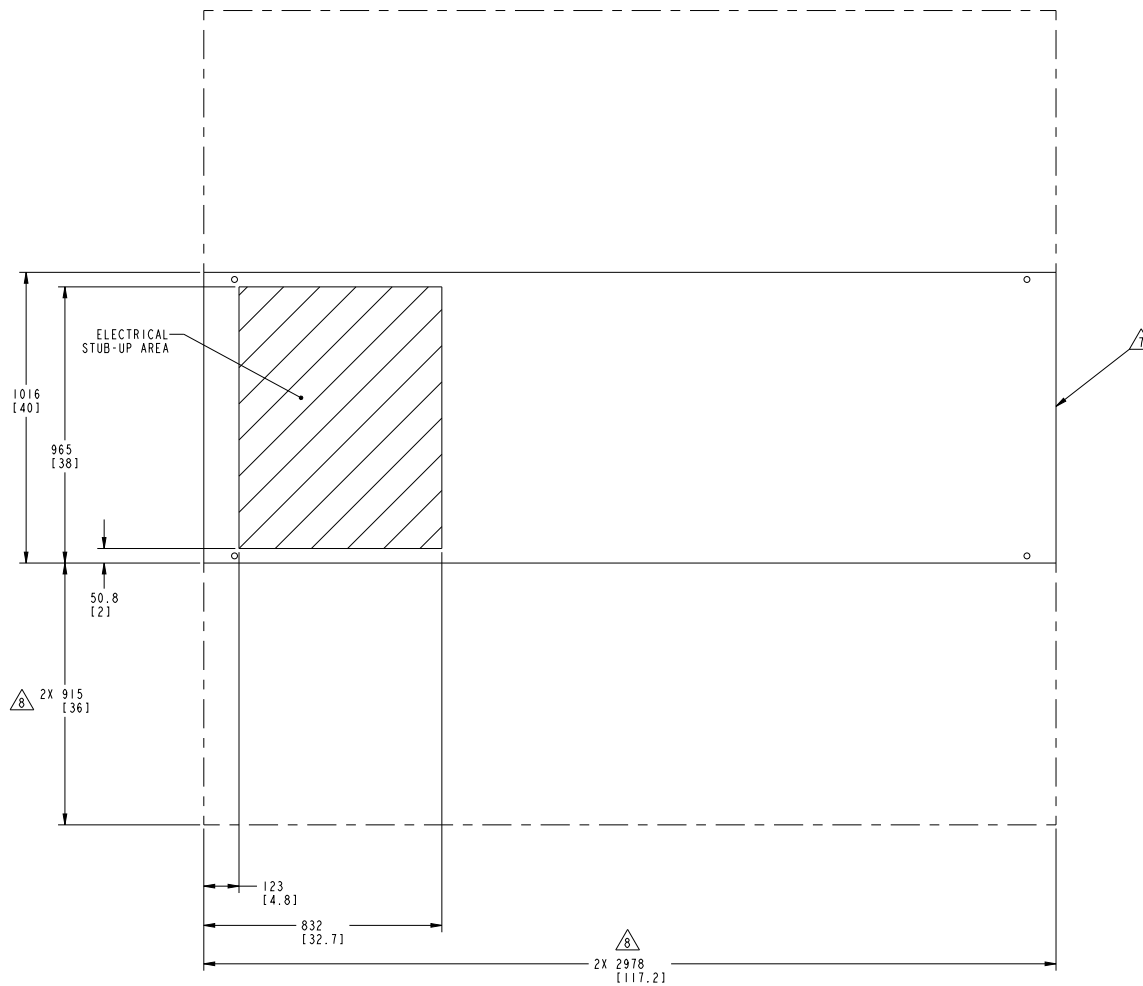

UNLESS OTHERWISE SPECIFIED, ALL DIMENSIONS ARE IN MILLIMETERS		DO NOT SCALE PRINT	APP'D	DATE	DATE	DATE	DATE
X ± 1	0.00 - 4.99 +0.15/-0.00		D HOFMEISTER				
-4 ± 0.8	5.00 - 9.99 +0.20/-0.10		D HOFMEISTER				
±0.38	10.00 - 17.49 +0.25/-0.13		M JAWALE				
	17.50 - 24.99 +0.30/-0.13						
ANG TOL	SCALE	DATE	DATE	DATE	DATE	DATE	DATE
± 1.0°	1:8						



UNLESS OTHERWISE SPECIFIED,
ALL DIMENSIONS ARE IN INCHES

TOLERANCES:
FRACTIONAL: 1/4
.X: .06
.XX: .03
.XXX: .01
ANGLES: .5

REFERENCES:
A054Y897
A051P365
A051P453

A054T898
A049J18

PREP. BY: KDU
CHKD. BY: -
MODIFIED BY: -
FINISH: N/A

ENGINE FAMILY: QSB5 ENGINE
BASIC FUEL TANK

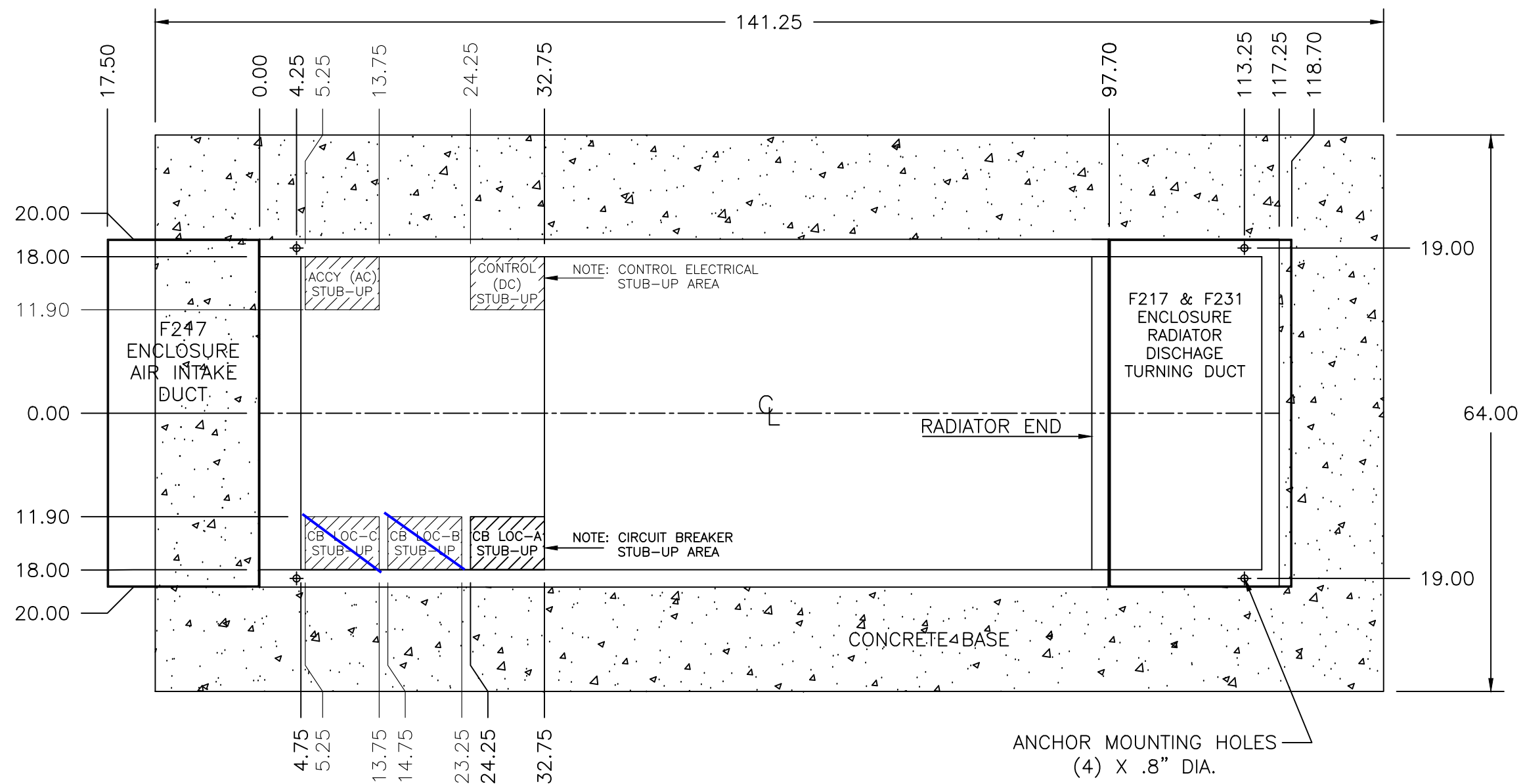

NOTE: SUGGESTED PAD LAYOUT SHOWN FOR REFERENCE.
SUGGESTED SERVICE ACCESS CLEARANCE 5 FEET.
ENCLOSURE ROOM AIR FLOW SHALL BE UNOBSTRUCTED-RESTRICTIVE.
RADIATOR DISCHARGE AIR FLOW SHALL BE UNOBSTRUCTED.
RADIATOR DISCHARGE AIR RE-CIRCULATION SHALL NOT BE PERMITTED.
GENERATOR SET SKID.

REF: GENERATOR SET DRAWING A054Y897
REF: GENERATOR SET/ENCLOSURE DRAWING A051P365
REF: GENERATOR SET/FUEL TANK DRAWING A054T898



SITE NAME:	CONTACT NAME:	CUSTOMER PROJECT NO:	TITLE:
CONTRACTOR NAME:	CONTACT NO:	CSSNA PROJECT NO:	50 KW THRU 125 KW DIESEL GENERATOR SET ENCLOSURE & BASIC FUEL TANK
			SIZE: C DWG NO: C50 D6C THRU C125 D6C STUB-UP REV A
			SCALE: NONE DO NOT SCALE PRINT SHEET 1 OF 1

AC ACCESSORY LOAD TABLE

CUSTOMER AC CONNECTION TERMINALS

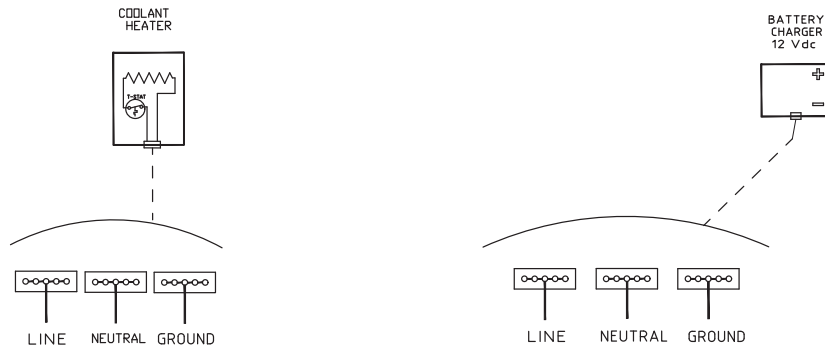

COOLANT HEATER 1000 WATTS, 120 VAC, 8.33 AMPS
 BATTERY CHARGER 192 WATTS, 120 VAC, 1.67 AMPS

NOTES:

1. INSTALLER TO PROVIDE BRANCH CIRCUITS TO POWER ALL ACCESSORIES
2. ALL ACCESSORIES ARE SINGLE PHASE 120/240 Vac 60 Hz
3. FOLLOW REGIONAL REGULATIONS AND APPLICABLE ELECTRIC CODES FOR INSTALLATION

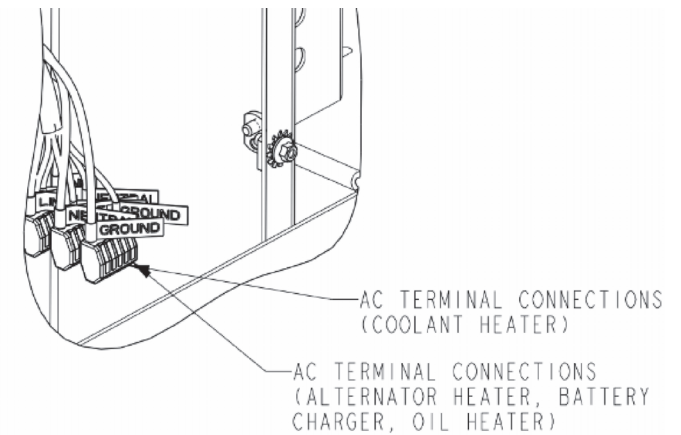

UNLESS OTHERWISE SPECIFIED,
 ALL DIMENSIONS ARE IN INCHES

PREP. BY: JPK 12/3/2024



CSSNA POWER GEN

TITLE: C-SERIES AC LOAD TABLE

SIZE: B DWG NO:

REV 3

SCALE:

DO NOT SCALE PRINT

SHEET

1 OF 1

SECTION 5

Warranty





Warranty Statement

Global Commercial Warranty Statement

Generator Set

Limited Warranty

Commercial Generating Set

This limited warranty applies to all Cummins Power Generation® branded commercial generating sets and associated accessories (hereinafter referred to as "Product").

This warranty covers any failures of the Product, under normal use and service, which result from a defect in material or factory workmanship.

Warranty Period:

The warranty start date[†] is the date of initial start up, first rental, demonstration or 18 months after factory ship date, whichever is sooner. See table for details.

Continuous Power (COP) is defined as being the maximum power which the generating set is capable of delivering continuously whilst supplying a constant electrical load when operated for an unlimited number of hours per year. No overload capability is available for this rating.

Prime Power (PRP) is defined as being the maximum power which a generating set is capable of delivering continuously whilst supplying a variable electrical load when operated for an unlimited number of hours per year. The permissible average power output over 24 hours of operation shall not exceed 70% of the PRP. For applications requiring permissible average output higher than stated, a COP rating should be used.

Limited-Time Running Power (LTP) is defined as the maximum power available, under the agreed operating conditions, for which the generating set is capable of delivering for up to 500 hours of operation per year.

Emergency Standby Power (ESP) is defined as the maximum power available during a variable electrical power sequence, under the stated operating conditions, for which a generating set is capable of delivering in the event of a utility power outage or under test conditions for up to 500 hours of operation per year. The permissible average power output over 24 hours of operation shall not exceed 70% of the ESP.

Environmental Protection Agency – Stationary Emergency (EPA-SE) is defined as being the maximum power available during a variable electrical power sequence, under the stated operating conditions, for which a generator set is capable of delivering in the event of a utility power outage or under test conditions and used in strict accordance with the EPA NSPS for stationary engines, 40 CFR part 60, subparts IIII and JJJJ, where a reliable utility must be present. The permissible average power output over 24 hours of operation shall not exceed 70% of the EPA-SE.

Data Center Continuous (DCC) is defined as the maximum power which the generator is capable of delivering continuously to a constant or varying electrical load for unlimited hours in a data center application.

**Base Warranty Coverage Duration
(Whichever occurs first)**

Rating	Months	Max. Hours
COP	12	Unlimited
PRP	12	Unlimited
LTP	12	500 hrs
ESP	24	1000 hrs
EPA-SE	24	Unlimited
DCC	24	Unlimited

[†] Warranty start date for designated rental and oil and gas model Products is determined to be date of receipt of Product by the end customer.

Cummins Power Generation® Responsibilities:

In the event of a failure of the Product during the warranty period due to defects in material or workmanship, Cummins Power Generation® will only be responsible for the following costs:

- All parts and labor required to repair the Product.
- Reasonable travel expenses to and from the Product site location.
- Maintenance items that are contaminated or damaged by a warrantable failure.

Owner Responsibilities:

The owner will be responsible for the following:

- Notifying Cummins Power Generation® distributor or dealer within 30 days of the discovery of failure.
- Installing, operating, commissioning and maintaining the Product in accordance with Cummins Power Generation®'s published policies and guidelines.
- Providing evidence for date of commissioning.
- Providing sufficient access to and reasonable ability to remove the Product from the installation in the event of a warrantable failure.
- Incremental costs and expenses associated with Product removal and reinstallation resulting from non-standard installations.
- Costs associated with rental of generating sets used to replace the Product being repaired.
- Costs associated with labor overtime and premium shipping requested by the owner.
- All downtime expenses, fines, all applicable taxes, and other losses resulting from a warrantable failure.

Limitations:

This limited warranty does not cover Product failures resulting from:

- Inappropriate use relative to designated power rating.
- Inappropriate use relative to application guidelines.
- Inappropriate use of an EPA-SE application generator set relative to EPA's standards.
- Normal wear and tear.
- Improper and/or unauthorized installation.
- Negligence, accidents or misuse.
- Lack of maintenance or unauthorized repair.
- Noncompliance with any Cummins Power Generation® published guideline or policy.
- Use of improper or contaminated fuels, coolants or lubricants.
- Improper storage before and after commissioning.
- Owner's delay in making Product available after notification of potential Product problem.
- Replacement parts and accessories not authorized by Cummins Power Generation®.
- Use of Battle Short Mode.
- Owner or operator abuse or neglect such as: operation without adequate coolant or lubricants; overfueling; overspeeding; lack of maintenance to lubricating, cooling or air intake systems; late servicing and maintenance; improper storage, starting, warm-up, run-in or shutdown practices, or for progressive damage resulting from a defective shutdown or warning device.

- Damage to parts, fixtures, housings, attachments and accessory items that are not part of the generating set.

This limited warranty does not cover costs resulting from:

- Difficulty in gaining access to the Product.
- Damage to customer property.

A "Data center" is defined as a dedicated facility that house computers and associated equipment for data storage and data handling.

Reliable utility is defined as utility power without routine or regularly scheduled black-outs.

Please contact your local Cummins Power Generation® Distributor for clarification concerning these limitations.

CUMMINS POWER GENERATION® RIGHT TO FAILED COMPONENTS:

Failed components claimed under warranty remain the property of Cummins Power Generation®. Cummins Power Generation® has the right to reclaim any failed component that has been replaced under warranty.

Extended Warranty:

Cummins Power Generation® offers several levels of Extended Warranty Coverage. Please contact your local Cummins Power Generation® Distributor for details.

www.power.cummins.com

THE WARRANTIES SET FORTH HEREIN ARE THE SOLE WARRANTIES MADE BY CUMMINS POWER GENERATION® IN REGARD TO THE PRODUCT. CUMMINS POWER GENERATION® MAKES NO OTHER WARRANTIES, EXPRESS OR IMPLIED, OR OF MERCHANTABILITY OR FITNESS FOR A PARTICULAR PURPOSE.

IN NO EVENT IS CUMMINS POWER GENERATION® LIABLE FOR INCIDENTAL OR CONSEQUENTIAL DAMAGES.

This limited warranty shall be enforced to the maximum extent permitted by applicable law. This limited warranty gives the owner specific rights that may vary from state to state or from jurisdiction to jurisdiction.

Product Model Number: _____
 Product Serial Number: _____
 Date in Service: _____

power.cummins.com

Copyright © 2017 Cummins Inc. All rights reserved.

Cummins, the “C” logo, PowerCommand, AmpSentry, and InPower are trademarks of Cummins Inc.

Other company, product, or service names may be trademarks or service marks of others.

Specifications are subject to change without notice.

