

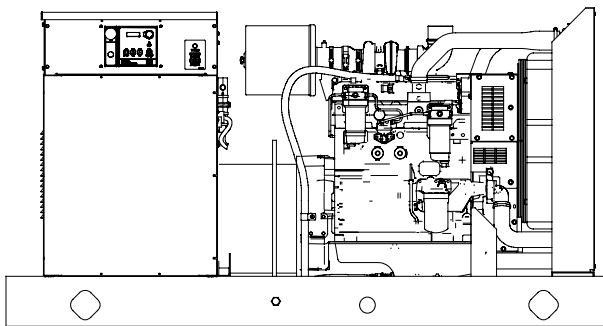

**Tier 3 EPA-Certified for Stationary Emergency Applications**

**Ratings Range**

		<b>60 Hz</b>
<b>Standby:</b>	<b>kW</b>	61-84
	<b>kVA</b>	61-105
<b>Prime:</b>	<b>kW</b>	56-76
	<b>kVA</b>	56-95



**Standard Features**

- Kohler Co. provides one-source responsibility for the generating system and accessories.
- The generator set and its components are prototype-tested, factory-built, and production-tested.
- The 60 Hz generator set offers a UL 2200 listing.
- The generator set accepts rated load in one step.
- The 60 Hz generator set meets NFPA 110, Level 1, when equipped with the necessary accessories and installed per NFPA standards.
- A one-year limited warranty covers all systems and components. Two-, five-, and ten-year extended warranties are also available.
- Alternator features:
  - The unique Fast-Response™ II excitation system delivers excellent voltage response and short-circuit capability using a permanent magnet (PM)-excited alternator.
  - The brushless, rotating-field alternator has broadrange reconnectability.
- Other features:
  - Controllers are available for all applications. See controller features inside.
  - The low coolant level shutdown prevents overheating (standard on radiator models only).
  - Integral vibration isolation eliminates the need for under-unit vibration spring isolators.
  - Multiple circuit breaker configurations.

**Generator Set Ratings**

Alternator	Voltage	Ph	Hz	130°C Rise Standby Rating		105°C Rise Prime Rating	
				kW/kVA	Amps	kW/kVA	Amps
4S7	120/208	3	60	80/100	278	72/90	250
	127/220	3	60	80/100	262	73/91	239
	120/240	3	60	80/100	241	72/90	217
	120/240	1	60	61/61	254	56/56	233
	139/240	3	60	81/101	244	74/93	223
	220/380	3	60	75/94	142	72/90	137
	277/480	3	60	81/101	122	74/93	111
4S9	347/600	3	60	81/101	97	74/93	89
	120/208	3	60	83/104	288	75/94	260
	127/220	3	60	83/104	272	76/95	249
	120/240	3	60	83/104	250	75/94	226
	120/240	1	60	80/80	333	71/71	296
	139/240	3	60	84/105	253	76/95	229
	220/380	3	60	83/104	158	75/94	142
4V9	277/480	3	60	83/104	125	76/95	114
	347/600	3	60	83/104	100	76/95	91

RATINGS: All three-phase units are rated at 0.8 power factor. All single-phase units are rated at 1.0 power factor. *Standby Ratings:* The standby rating is applicable to varying loads for the duration of a power outage. There is no overload capability for this rating. *Prime Power Ratings:* At varying load, the number of generator set operating hours is unlimited. A 10% overload capacity is available for one hour in twelve. Ratings are in accordance with ISO-8528-1 and ISO-3046-1. For limited running time and continuous ratings, consult the factory. Obtain technical information bulletin (TIB-101) for ratings guidelines, complete ratings definitions, and site condition derates. The generator set manufacturer reserves the right to change the design or specifications without notice and without any obligation or liability whatsoever.

# Alternator Specifications

Specifications	Alternator
Manufacturer	Kohler
Type	4-Pole, Rotating-Field
Exciter type	Brushless, Permanent-Magnet
Leads: quantity, type	12, Reconnectable
Voltage regulator	Solid State, Volts/Hz
Insulation:	NEMA MG1
Material	Class H
Temperature rise	130°C, Standby
Bearing: quantity, type	1, Sealed
Coupling	Flexible Disc
Amortisseur windings	Full
Voltage regulation, no-load to full-load	
Decision-Maker 550 controller (with 0.5% drift due to temp. variation)	3-Phase Sensing, ±0.25%
Decision-Maker® 3000 controller	3-Phase Sensing, ±0.5%
One-step load acceptance	100% of Rating
Unbalanced load capability	100% of Rated Standby Current

- NEMA MG1, IEEE, and ANSI standards compliance for temperature rise and motor starting.
- Sustained short-circuit current of up to 300% of the rated current for up to 10 seconds.
- Sustained short-circuit current enabling downstream circuit breakers to trip without collapsing the alternator field.
- Self-ventilated and drip-proof construction.
- Vacuum-impregnated windings with fungus-resistant epoxy varnish for dependability and long life.
- Superior voltage waveform from a two-thirds pitch stator and skewed rotor.
- Fast-Response™ II brushless alternator with brushless exciter for excellent load response.

Specifications	Alternator
Peak motor starting kVA:	(35% dip for voltages below)
480 V 4S7 (12 lead)	270
480 V 4S9 (12 lead)	315
240 V 4V9 (4 lead)	246

## Application Data

### Engine

Engine Specifications	
Manufacturer	John Deere
Engine model	4045HF285H
Engine type	4-Cycle, Turbocharged, Charge Air-Cooled
Cylinder arrangement	4 Inline
Displacement, L (cu. in.)	4.5 (276)
Bore and stroke, mm (in.)	106 x 127 (4.19 x 5.00)
Compression ratio	19:1
Piston speed, m/min. (ft./min.)	457 (1500)
Main bearings: quantity, type	5, Replaceable Insert
Rated rpm	1800
Max. power at rated rpm, kWm (BHP)	99 (133)
Cylinder head material	Cast Iron
Crankshaft material	Forged Steel
Valve material:	
Intake	Chromium-Silicon Steel
Exhaust	Stainless Steel
Governor: type, make/model	JDEC Electronic L16 Denso HP3
Frequency regulation, no-load to full-load	Isochronous
Frequency regulation, steady state	±0.25%
Frequency	Fixed
Air cleaner type, all models	Dry

### Engine Electrical

Engine Electrical System (12/24 Volt*)	
Battery charging alternator:	12 Volt/24 Volt
Ground (negative/positive)	Negative
Volts (DC)	12/24
Ampere rating	65/45
Starter motor rated voltage (DC)	12/24
Battery, recommended cold cranking amps (CCA):	12 Volt/24 Volt
Quantity, CCA rating each	One, 640/Two, 570
Battery voltage (DC)	12

\*12-volt or 24-volt engine electrical systems are available.

### Fuel

Fuel System	
Fuel supply line, min. ID, mm (in.)	11.0 (0.44)
Fuel return line, min. ID, mm (in.)	6.0 (0.25)
Fuel filter	
Secondary	2 Microns @ 98% Efficiency
Water Separator	Yes
Recommended fuel	#2 Diesel
Max. lift, fuel pump: type, m (ft.)	Engine-Driven, 1.8 (6.0)
Fuel prime pump	Manual
Primary	30 Microns
Max. fuel flow, Lph (gph)	62.5 (16.5)

### Exhaust

Exhaust System	
Exhaust manifold type	Dry
Exhaust flow at rated kW, m <sup>3</sup> /min. (cfm)	19.2 (679)
Exhaust temperature at rated kW, dry exhaust, °C (°F)	579 (1074)
Maximum allowable back pressure, kPa (in. Hg)	7.5 (2.2)
Exhaust outlet size at engine hookup, mm (in.)	98 (3.86)

### Lubrication

Lubricating System	
Type	Full Pressure
Oil pan capacity, L (qt.)	14.7 (15.5)
Oil pan capacity with filter, L (qt.)	15.6 (16.5)
Oil filter: quantity, type	1, Cartridge
Oil cooler	Water-Cooled

# Application Data

## Cooling

Radiator System	
Ambient temperature, °C (°F)	50 (122)
Engine jacket water capacity, L (gal.)	8.5 (2.25)
Radiator system capacity, including engine, L (gal.)	20.1 (5.3)
Engine jacket water flow, Lpm (gpm)	155 (41)
Heat rejected to cooling water at rated kW, dry exhaust, kW (Btu/min.)	54.4 (3096)
Heat rejected to air charge cooler at rated kW, dry exhaust, kW (Btu/min.)	13.5 (768)
Water pump type	Centrifugal
Fan diameter, including blades, mm (in.)	600 (23.6)
Fan, kWm (HP)	6.6 (8.8)
Max. restriction of cooling air, intake and discharge side of radiator, kPa (in. H <sub>2</sub> O)	0.125 (0.5)

## Operation Requirements

Air Requirements	
Radiator-cooled cooling air, m <sup>3</sup> /min. (scfm)‡	142 (5000)
Combustion air, m <sup>3</sup> /min. (cfm)	6.9 (244)
Heat rejected to ambient air:	
Engine, kW (Btu/min.)	22.9 (1300)
Alternator, kW (Btu/min.)	9.8 (560)
‡ Air density = 1.20 kg/m <sup>3</sup> (0.075 lbm/ft <sup>3</sup> )	

Fuel Consumption		
Diesel, Lph (gph) at % load	Standby Rating	
100%	26.1	(6.9)
75%	21.2	(5.6)
50%	15.5	(4.1)
25%	8.3	(2.2)
Diesel, Lph (gph) at % load	Prime Rating	
100%	23.8	(6.3)
75%	19.3	(5.1)
50%	14.4	(3.8)
25%	7.9	(2.1)

## Controllers

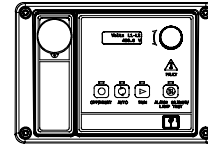

### Decision-Maker® 3000 Controller

Provides advanced control, system monitoring, and system diagnostics for optimum performance and compatibility.

- Digital display and menu control provide easy local data access
- Measurements are selectable in metric or English units
- Scrolling display shows critical data at a glance
- Integrated hybrid voltage regulator with ±0.5% regulation
- Built-in alternator thermal overload protection
- NFPA 110 Level 1 capability

Refer to G6-100 for additional controller features and accessories.

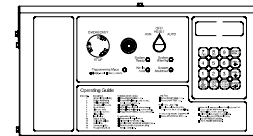

### Decision-Maker® 550 Controller

Provides advanced control, system monitoring, and system diagnostics with remote monitoring capabilities.

- Digital display and keypad provide easy local data access
- Measurements are selectable in metric or English units
- Remote communication thru a PC via network or modem configuration
- Controller supports Modbus® protocol
- Integrated voltage regulator with ±0.25% regulation
- Built-in alternator thermal overload protection
- NFPA 110 Level 1 capability

Refer to G6-46 for additional controller features and accessories.

## Additional Standard Features

- Alternator Protection  
(standard with Decision-Maker® 550 controller only)
- Battery Rack and Cables
- Local Emergency Switch
- Oil Drain Extension
- Operation and Installation Literature

## Available Options

### Approvals and Listings

- CSA Approval
- IBC Seismic Certification
- UL 2200 Listing

### Enclosed Unit

- Sound Enclosure (with enclosed critical silencer)
- Weather Enclosure (with enclosed critical silencer)

### Open Unit

- Exhaust Silencer, Critical (kit: PA-354809)
- Exhaust Silencer, Hospital (kit: PA-365349)
- Flexible Exhaust Connector, Stainless Steel

### Fuel System

- Auxiliary Fuel Pump
- Flexible Fuel Lines
- Fuel Pressure Gauge
- Subbase Fuel Tanks

### Controller

- Common Failure Relay
- Communication Products and PC Software  
(Decision-Maker® 550 controller only)
- Customer Connection (Decision-Maker® 550 controller only)
- Dry Contact (isolated alarm) (Decision-Maker® 550 controller only)
- Input/Output Module (Decision-Maker® 3000 controller only)
- Remote Audiovisual Alarm Panel  
(Decision-Maker® 550 controller only)
- Prime Power Switch (Decision-Maker® 550 controller only)
- Remote Emergency Stop
- Remote Serial Annunciator Panel
- Run Relay

### Cooling System

- Block Heater  
(recommended for ambient temperatures below 0°C [32°F])
- Radiator Duct Flange

### Electrical System

- Alternator Strip Heater
- Battery
- Battery Charger, Equalize/Float Type
- Battery Heater
- Line Circuit Breaker (NEMA type 1 enclosure)
- Line Circuit Breaker with Shunt Trip (NEMA type 1 enclosure)

### Paralleling System

- Voltage Adjust Control

### Miscellaneous

- Air Cleaner, Heavy Duty
- Air Cleaner Restriction Indicator
- Crankcase Emissions Canister
- Engine Fluids (oil and coolant) Added
- Rated Power Factor Testing
- Rodent Guards
- Skid End Caps

### Literature

- General Maintenance
- NFPA 110
- Overhaul
- Production

### Warranty

- 2-Year Basic
- 2-Year Prime
- 5-Year Basic
- 5-Year Comprehensive
- 10-Year Major Components

### Other Options

- \_\_\_\_\_
- \_\_\_\_\_
- \_\_\_\_\_
- \_\_\_\_\_
- \_\_\_\_\_

## Dimensions and Weights

Overall Size, L x W x H, mm (in.):

Wide Skid: See Enclosure ADV Drawing

Narrow Skid: 2334 x 864 x 1216 (91.89 x 34.02 x 47.90)

Weight (radiator model), wet, kg (lb.): 1125 (2480)

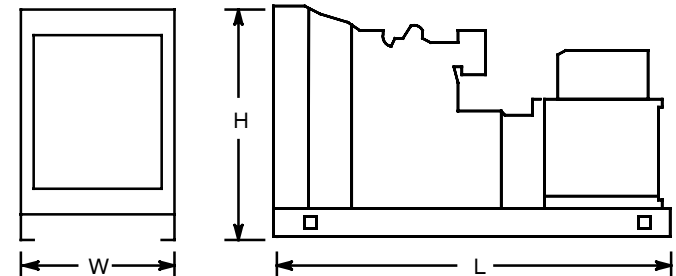

NOTE: This drawing is provided for reference only and should not be used for planning installation. Contact your local distributor for more detailed information.

### DISTRIBUTED BY: