

CAT C27 D800GC Generator Set Submittal



Image may not reflect actual configuration.

TABLE OF CONTENTS

TAB 1: GENERAL INFORMATION

- 1.1 Bill of Materials
- 1.2 Notes & Exceptions
- 1.3 Interconnect Diagram

TAB 2: DRAWINGS

- 2.1 Package Generator Set Drawings

TAB 3: GENERATOR CUTSHEETS

- 3.1 UL 2200 Certification
- 3.2 EPA Certificate
- 3.3 Caterpillar Standby Generator Set Datasheet
- 3.4 Technical Generator Data
- 3.5 Performance Data
- 3.6 Auxiliary Equipment Data
 - 3.6.1 Automatic Voltage Regulator
 - 3.6.2 ADEM A4 Engine Governor
 - 3.6.3 GCCP 1.2 Generator Set Controller
 - 3.6.3.1 Remote Annunciator Module
 - 3.6.3.2 Remote Emergency Stop Pushbutton Station
 - 3.6.4 UL-Listed Circuit Breaker
 - 3.6.5 Engine Starting Battery Set
 - 3.6.6 UL-Listed Battery Charger
 - 3.6.7 Jacket Water Heater
 - 3.6.8 100A Auxiliary Load Center
 - 3.6.9 CAT Sound Attenuated Enclosure
 - 3.6.10 CAT Integral Fuel Tank

TAB 4: REVISION HISTORY AND APPROVALS PAGE

- 4.1 Caterpillar Warranty Card
- 4.2 Revision History and Approval

TAB 1: GENERAL INFORMATION

- 1.1 Bill of Materials
- 1.2 Notes & Exceptions
- 1.3 Interconnect Diagram

BILL OF MATERIALS

Generator Set

Approximate Dimensions: 301"L x 93"W x 131"H

Approximate Dry Weight: 26,537 lbs.

Approximate Wet Weight: 41,237 lbs.

EXTENDED DESCRIPTION:

Qty. (1) CAT Standby Rated Diesel Generator Set

Model: C27

Nameplate Rating: 800kW / 1000kVA, U.S. EPA STATIONARY EMERGENCY (TIER 2)

Voltage: 480Y, 3-phase, 4-wire, 60 Hz

Certifications: UL 2200

Engine: **#2 ULSD** Engine, 1800 RPM, Electronic Engine Controller

Cooling System:

Unit Mounted Radiator

Rated for operation in 122°F ambient temperature

50/50 Antifreeze & Water Mixture

Starting System:

Heavy Duty Electric Starting Motor

12V Lead Acid Battery Set, 1000 CCA, 140 AH, 12VDC

UL Listed Battery Charger:

10ADC Maximum Charging Current

NFPA 110 Alarm Contacts

Jacket Water Heater (to facilitate quicker starting times)

Alternator End & Attachments:

E3835L4 Frame Generator, Single Bearing, Rated for 105°C Temperature Rise

2/3 Pitch, Random Wound

Automatic Voltage Regulator

Enclosure & Mounting System:

Generator Set is suitable for outdoor installation.

Sound Attenuated Enclosure (75 dBa @ 23 feet, free field)

Fuel System:

2,100 Gallon Integral Fuel Tank (36 Hours @ Full Load)

Control Panel:

GCCP 1.2 Control Panel

Qty. (1) NFPA 110 Compliant Remote Annunciator Panel

Qty. (1) NFPA 110 Compliant Local Annunciator

Circuit Breaker:

Qty. (1) 1200A, 100% Rated Manually-Operated Circuit Breaker with Adjustable LSI Trip

Factory and Onsite Testing, Startup, and Commissioning:

PGS Test Report at 0.8 PF

CAT Startup Services with CAT certified technicians (includes lube oil and coolant)

2-hour 1.0PF Resistive Load Bank Testing Included

NOTES, CLARIFICATIONS, DEVIATIONS, AND EXCEPTIONS

NOTES

1. This submittal is based on the following documents (no other documents or plans have been reviewed):
 - a. Customer request – Tony Barras, dated 4/11/24.
2. Proposal scope limited to items specifically listed in this proposal.
3. Fuel for startup or testing not included.
4. Temporary generator set (if required) not included in Empire's scope of work or supply.
5. Offloading not included.
6. Installation, including but not limited to: anchoring, electrical conduit, fuel oil and exhaust piping, interconnecting wire and cable, not included.
7. NETA testing to be done by others (independent testing agency)
8. Protective device coordination, short circuit study, and arc flash analysis by others.
9. Ground testing by others.
10. Scope of Work/Supply is based on all onsite work being performed M-F 8AM-4PM. Weekend and/or overtime service hours are available. A copy of our non-standard service rates is available upon request. Four (4) week notice is required for field service.

CLARIFICATIONS, DEVIATIONS, EXCEPTIONS (C/D/E)

1. A full submittal will be issued for review and approval before equipment is released to order.
2. All installation provided by others.
3. All nameplates, infrared scanning and coordination study provided by others.

GENERATOR WORK SCOPE

EMPIRE SOUTHWEST'S SCOPE OF SUPPLY

1. Provide freight to jobsite.
2. Provide Project Manager and Project Engineering services to supervise/assist installing contractor to ensure proper installation.
3. Terminate all control/interconnect wiring.
4. Provide onsite startup and commissioning services.
5. Provide equipment manuals and in-person training sessions.

CUSTOMER/INSTALLING CONTRACTOR'S SCOPE OF SUPPLY

1. Provide offloading of all equipment delivered to site (generator set will require a large crane to offload and set).
2. Set all equipment (anchoring to pad).
3. Provide and install all required conduit, fuel lines (external to generator set fuel tank), and other infrastructure external to generator set package.
4. Provide and terminate all power/feeder cabling (including power source for generator set auxiliaries).
5. Provide all required control/interconnect wiring.

NOT INCLUDED IN EMPIRE SOUTHWEST'S SCOPE OF SUPPLY

1. Permits (fuel tank, emissions, etc.). Any permitting and testing related to Title V compliance and/or other local air board compliance is by others.
2. Coordination of testing with facility load.
3. Fuel for testing finished installation.

Project Specific Notes and Technical Information

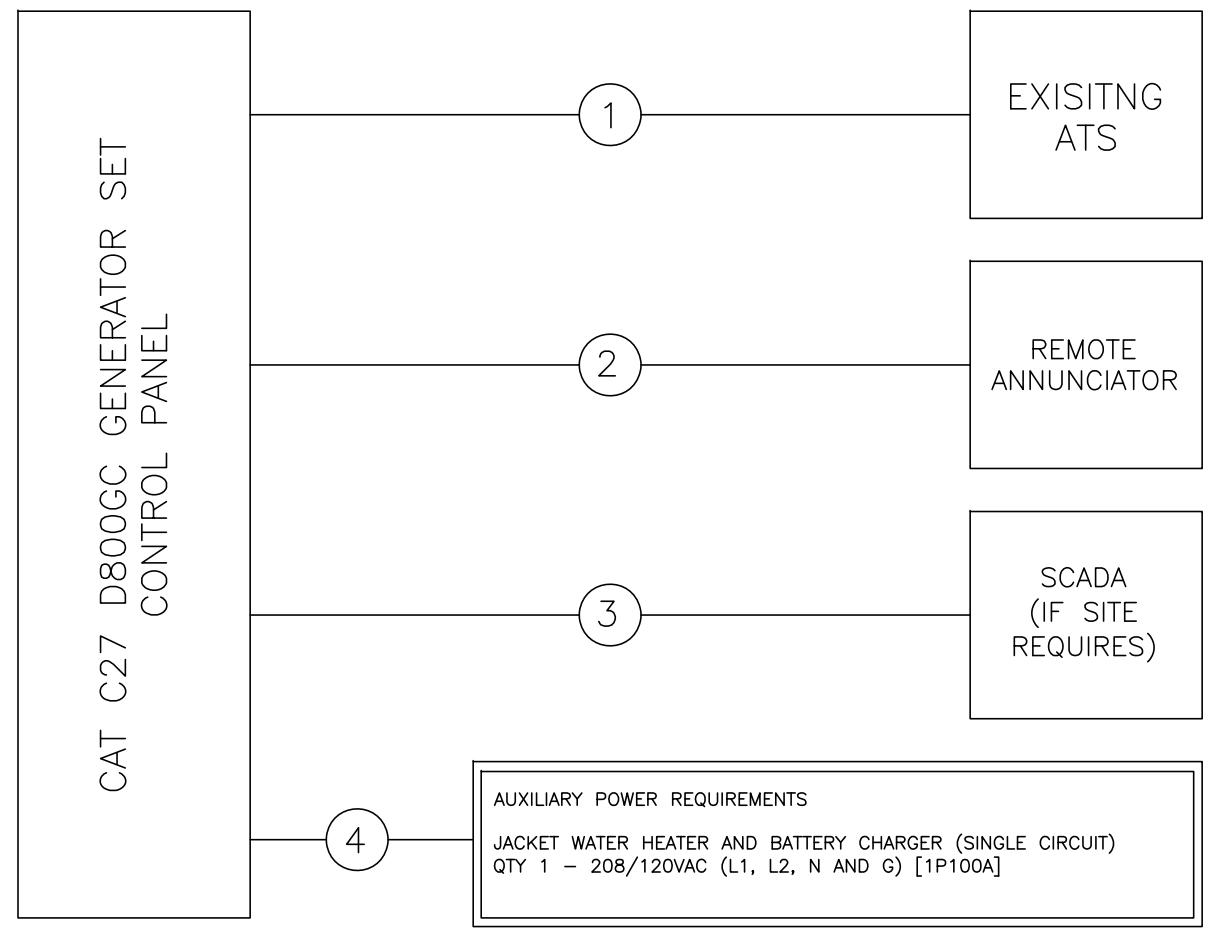

CONDUIT	REQUIRED WIRING	VOLTAGE/TYPE	PURPOSE	RECOMMENDED CONDUIT SIZE	FROM	TO
1	Qty. (8) 14AWG THHN	24VDC/Dry Contact	Load Shed, Start Signal, Switch Position, and Spare	1/2"	CAT C27 D800GC GENERATOR SET	EXISTING ATS
2	Qty. (4) 10AWG THHN	24VDC/Dry Contact	Remote Annunciator Power	3/4"	CAT C27 D800GC GENERATOR SET	REMOTE ANNUNCIATOR
	Qty. (1) Belden 9841 or Approved Equal	5VDC				
3	Qty. (1) Belden 9841 or Approved Equal	5VDC	Modbus RTU Communications	1/2"	CAT C27 D800GC GENERATOR SET	SCADA (IF SITE REQUIRES)
4	100A, 208/120VAC, 1-Phase Service	208/120VAC	Auxiliary Power	By Installing Contractor	Site Provided Auxiliary Panelboard	CAT C27 D800GC GENERATOR SET

STATE OF NV - DATA CENTER

DRN	P. PHEM		
CHK	G. TORRES		
APPD	G. TORRES		
DATE			
EXP			
PROG			

UNLESS OTHERWISE SPECIFIED
DIMENSIONS ARE IN MM (INCH)
DIMENSIONS W/O TOL ARE BASIC

SCALE: NTS

SHEET 1 of 1

19JAN2024

CHG DATE

EMPIRE SOUTHWEST

TAB 2: DRAWINGS

2.1 Package Generator Set Drawings

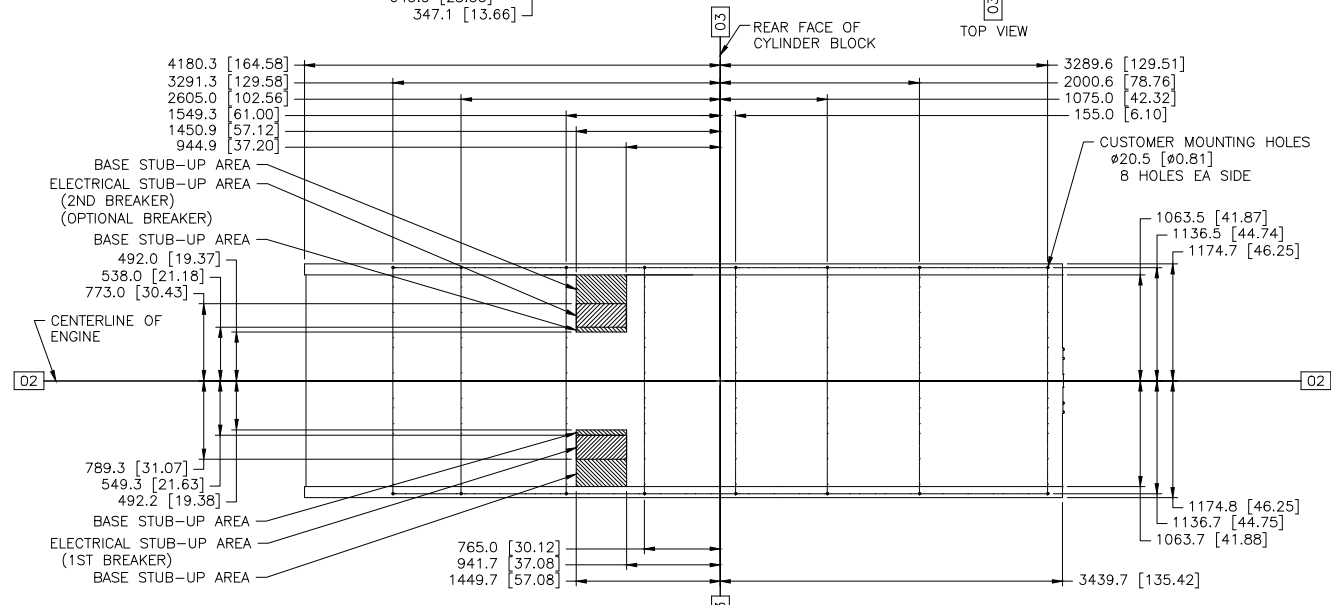

FOOT PRINT
(DIMENSIONED OUTLINE VIEW FROM ABOVE)
(RIGHT SIDE ORIENTATION)

LF-5687 WITH LF-5686 SHOWN

DATE			
BY			
CHKD			
APP'D			
REV			
1	12738	DRAWING - AUTOCAD	
2	13018	REVISION MARKINGS	
3	13001	CONFIDENTIALITY	
4	13001	TRAINING OPERATION	
5	13001	INSTR & I/O	
6			
7			
8			
9			
10			
11			
12			
13			
14			
15			
16			
17			
18			
19			
20			
21			
22			
23			
24			
25			
26			
27			
28			
29			
30			
31			
32			
33			
34			
35			
36			
37			
38			
39			
40			
41			
42			
43			
44			
45			
46			
47			
48			
49			
50			
51			
52			
53			
54			
55			
56			
57			
58			
59			
60			
61			
62			
63			
64			
65			
66			
67			
68			
69			
70			
71			
72			
73			
74			
75			
76			
77			
78			
79			
80			
81			
82			
83			
84			
85			
86			
87			
88			
89			
90			
91			
92			
93			
94			
95			
96			
97			
98			
99			
100			

ENTERPRISE INC.
INSTALLATION ATTACHMENT
ENCLOSURES AND TANKS
631-1828

TAB 3: GENERATOR CUTSHEETS

- 3.1 UL 2200 Certification
- 3.2 EPA Certificate
- 3.3 Caterpillar Standby Generator Set Datasheet
- 3.4 Technical Generator Data
- 3.5 Performance Data
- 3.6 Auxiliary Equipment Data
 - 3.6.1 Automatic Voltage Regulator
 - 3.6.2 ADEM A4 Engine Governor
 - 3.6.3 GCCP 1.2 Generator Set Controller
 - 3.6.3.1 Remote Annunciator Module
 - 3.6.3.2 Remote Emergency Stop Pushbutton Station
 - 3.6.4 UL-Listed Circuit Breaker
 - 3.6.5 Engine Starting Battery Set
 - 3.6.6 UL-Listed Battery Charger
 - 3.6.7 Jacket Water Heater
 - 3.6.8 100A Auxiliary Load Center
 - 3.6.9 CAT Sound Attenuated Enclosure
 - 3.6.10 CAT Integral Fuel Tank



ULCERT UL 2200 LISTING

INCLUDES THE FOLLOWING:

ALTERNATOR

Alternator insulation system is UL Recognized (UL 1446). PMG and AREP alternators are available. Automatic voltage regulators are UL Recognized.

WIRE HARNESS

AC, DC, and power harnesses are made with UL Listed wire and UL Listed terminals.

CONTROL PANEL

Control panels are comprised of UL Listed and UL Recognized components. EMCP is UL Recognized.

CIRCUIT BREAKER

Output circuit breaker is 100% rated and UL Listed.

TESTING

All UL Listed sets are designed and rigorously tested in accordance with UL Standard for Safety, UL 2200.

LABELING

Labeling meets UL requirements.

MECHANICAL OPTIONS

Mechanical options do not require UL Listing and, therefore, are not affected. The exceptions to this are:

FUEL TANKS

If a fuel tank is ordered with the unit, it must be UL Listed. Two versions are available: 24 hour integral (FCUL2) and 24/48 hour sub-base (FSBT)

ENCLOSURES

Factory installed enclosures meet UL requirements. Weatherproof and sound attenuated versions are

available.

ELECTRICAL OPTIONS

The table below shows electrical options that meet UL requirements:

EOS	Lube Oil Sump Heater
WCA1	Low Coolant Level Shutdown
WSS1	Low Coolant Temperature Alarm
AH1H	Anti-Condensation Heater
WHH	Coolant Heater
GOVES	Electronic Governor (Fully Adjustable)
FSS1	Critical Low Fuel Level Shutdown
FSS2	Low Fuel Level Alarm
FSSS	Critical High Fuel Alarm
PBCSUL	UL Listed Battery Charger
PBC10NU	NFPA Battery Charger, UL Listed

UL Listing is available on all diesel fuelled generator sets up to 17S kW at 60 Hz, 600 vac maximum.

LEHE0410-01 (11-

BUILT FOR IT.™

www.Cat.com/electricpower

©2018 Caterpillar All rights reserved. Materials and specifications are subject to change without notice. The International System of Units (SI) is used in this publication. CAT, CATERPILLAR, their respective logos, ADEM, S•O•S, "BUILT FOR IT", "Caterpillar Yellow", the "Power Edge" trade dress as well as corporate and product identity used herein, are trademarks of Caterpillar and may not be used without permission.



**UNITED STATES ENVIRONMENTAL PROTECTION AGENCY
2023 MODEL YEAR
CERTIFICATE OF CONFORMITY
WITH THE CLEAN AIR ACT**

**OFFICE OF TRANSPORTATION
AND AIR QUALITY
ANN ARBOR, MICHIGAN 48105**

Certificate Issued To: Caterpillar Inc.
(U.S. Manufacturer or Importer)
Certificate Number: PCPXL27.0NZS-006

Effective Date:
06/08/2022
Expiration Date:
12/31/2023

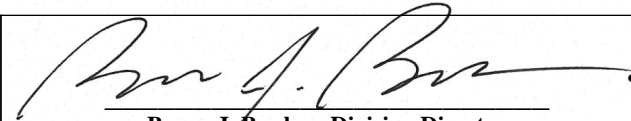
Byron J. Bunker, Division Director
Compliance Division

Issue Date:
06/08/2022
Revision Date:
N/A

Model Year: 2023
Manufacturer Type: Original Engine Manufacturer
Engine Family: PCPXL27.0NZS

Mobile/Stationary Indicator: Stationary
Emissions Power Category: 560<kW<=2237
Fuel Type: Diesel
After Treatment Devices: No After Treatment Devices Installed
Non-after Treatment Devices: Electronic Control, Engine Design Modification

Pursuant to Section 111 and Section 213 of the Clean Air Act (42 U.S.C. sections 7411 and 7547) and 40 CFR Part 60, and subject to the terms and conditions prescribed in those provisions, this certificate of conformity is hereby issued with respect to the test engines which have been found to conform to applicable requirements and which represent the following engines, by engine family, more fully described in the documentation required by 40 CFR Part 60 and produced in the stated model year.

This certificate of conformity covers only those new compression-ignition engines which conform in all material respects to the design specifications that applied to those engines described in the documentation required by 40 CFR Part 60 and which are produced during the model year stated on this certificate of the said manufacturer, as defined in 40 CFR Part 60.

It is a term of this certificate that the manufacturer shall consent to all inspections described in 40 CFR 1068 and authorized in a warrant or court order. Failure to comply with the requirements of such a warrant or court order may lead to revocation or suspension of this certificate for reasons specified in 40 CFR Part 60. It is also a term of this certificate that this certificate may be revoked or suspended or rendered void *ab initio* for other reasons specified in 40 CFR Part 60.

This certificate does not cover engines sold, offered for sale, or introduced, or delivered for introduction, into commerce in the U.S. prior to the effective date of the certificate.

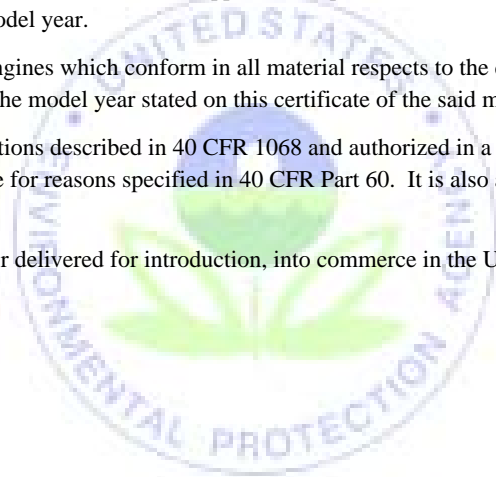

Cat® D800 GC

Diesel Generator Sets



Image shown might not reflect actual configuration.

Engine	C27
Bore – mm (in)	137.2 (5.4)
Stroke – mm (in)	152.4 (6.0)
Displacement – L (in ³)	27.03 (1649.47)
Compression Ratio	16.5:1
Aspiration	TA
Fuel System	MEUI
Governor Type	ADEM™ A4

Model	Standby 60 Hz ekW (kVA)	Emissions Performance
D800 GC	800 (1000)	U.S EPA Emergency Stationary Use only (Tier 2)

Standard Features

Cat® Diesel Engine

- Meets U.S. EPA Emergency Stationary Use only (Tier 2) emission standards
- Reliable performance proven in thousands of applications worldwide

Generator Set Package

- Accepts 100% block load in one step and meets NFPA 110 loading requirements
- Conforms to ISO 8528-5 G3 load acceptance requirements
- Reliability is verified through prototype testing, which includes torsional vibration, fuel consumption, oil consumption, transient performance, and endurance testing

Alternators

- Superior motor starting capability minimizes the need for oversizing the generator
- Designed to match the performance and output characteristics of Cat diesel engines

Cooling System

- Cooling systems available to operate in ambient temperatures TBD (To be validated)
- Tested to ensure proper generator set cooling

GCCP Control Panels

- User-friendly set-up and button layout for ease of use
- Multiple parameters are monitored & displayed simultaneously for full visibility
- The module can be configured to suit a wide range of applications for user flexibility

Warranty and Extended Service Coverage (ESC)

- 24 months/1000-hour warranty for standby ratings
- 5 yrs Gold Complimentary Extended Service Coverage

Worldwide Product Support

- Cat dealers have over 1,800 dealer branch stores operating in 200 countries
- Your local Cat dealer provides extensive post-sale support, including maintenance and repair agreements

Financing

- Caterpillar offers an array of financial products to help you succeed through financial service excellence
- Options include loans, finance lease, operating lease, working capital, and revolving line of credit
- Contact your local Cat dealer for availability in your region

Standard and Optional Equipment

Engine

Air Cleaner

- Open element
- Dual element

Starting

- Standard batteries
- Oversized batteries
- Dual Electric Starters
- Jacket water heater

Engine Attachments

- 6" Exhaust Flexible Fittings
- 6" Exhaust Flange Kits
- Radiator Duct Flange

Alternator

Output voltage

- 480V
- 600V

Temperature Rise (over 40°C ambient)

- 125°C
- 105°C

Winding type

- Random wound

Excitation

- Internal excitation (IE)
- Permanent magnet (PM)

Attachments

- Anti-condensation heater

Power Termination

Type

- Circuit breaker (Primary)
- 1200A 1600A 2000A
- Circuit breaker (Auxiliary)
- 250A 400A
- 3-pole
- Manually operated

Trip Unit

- LSI LSIG LSIG-P

Factory Enclosure

- Sound attenuated
- Weatherproof

Attachments

- DC lighting package

Fuel Tank

- Intergrated 2100 gal (7950 L)
- Sub base 3000 gal (11356 L)
- Sub base 4200 gal (15876 L)

Control System

Controller

- GCCP 1.2

Attachments

- Remote annunciator module
- Expansion I/O module
- 100A Load Center
- 20A GFCI AC Receptacle
- Ground Fault Indication
- Audible Alarm

Charging

- Battery charger – 10A (Installed)
- Battery charger – 20A
(Shipped loose)

Cat Connect

Connectivity

- Ethernet
- Cellular

Extended Service Options

Terms

- 3 year
- 4 year
- 5 year

Coverage

- Silver
- Gold

Certifications

- UL 2200 Listed
- cUL CSA 22.2 No. 100-14
- IBC seismic certification

Note: Some options may not be available on all models. Certifications may not be available with all model configurations. Consult factory for availability.

D800 GC Diesel Generator Sets

Electric Power



Package Performance – D800 GC

Performance	Standby	
Frequency	60 Hz	
Gen set power rating with fan	800 ekW	
Gen set power rating with fan @ 0.8 power factor	1000 kVA	
Fueling strategy	EPA ESE (Tier 2)	
Performance number	DM7696	
Fuel Consumption		
100% load with fan – L/hr (gal/hr)	216.9	(57.3)
75% load with fan – L/hr (gal/hr)	171.7	(45.4)
50% load with fan – L/hr (gal/hr)	122.3	(32.3)
25% load with fan – L/hr (gal/hr)	73.9	(19.5)
Cooling System		
Radiator air flow restriction (system) – kPa (in. water)	0.12	(0.48)
Radiator air flow – m ³ /min (cfm)	943	(33301)
Engine coolant capacity – L (gal)	55	(14.5)
Radiator coolant capacity – L (gal)	49	(12.9)
Total coolant capacity – L (gal)	104	(27.5)
Inlet Air		
Combustion air inlet flow rate – m ³ /min (cfm)	62.8	(2216.4)
Exhaust System		
Exhaust stack gas temperature – °C (°F)	511.4	(952.5)
Exhaust gas flow rate – m ³ /min (cfm)	170.3	(6011.7)
Exhaust system backpressure (maximum allowable) – kPa (in. water)	6.7	(27.0)
Heat Rejection		
Heat rejection to jacket water – kW (Btu/min)	330	(18785)
Heat rejection to exhaust (total) – kW (Btu/min)	796	(45257)
Heat rejection to aftercooler – kW (Btu/min)	162	(9235)
Heat rejection to atmosphere from engine – kW (Btu/min)	110	(6240)
Heat rejection from alternator – kW (Btu/min)	40	(2292)
Emissions* (Nominal)		
NOx mg/Nm ³ (g/hp-h)	2580	(5.18)
CO mg/Nm ³ (g/hp-h)	115.1	(0.23)
HC mg/Nm ³ (g/hp-h)	12.5	(0.03)
PM mg/Nm ³ (g/hp-h)	9.7	(0.02)

*mg/Nm³ levels are corrected to 5% O₂. Contact your local Cat dealer for further information.

D800 GC Diesel Generator Sets

Electric Power



Weights and Dimensions

Do not use for construction.
This does not include fuel tank and enclosure. Refer to Tab 2 Drawings for exact dimensions.

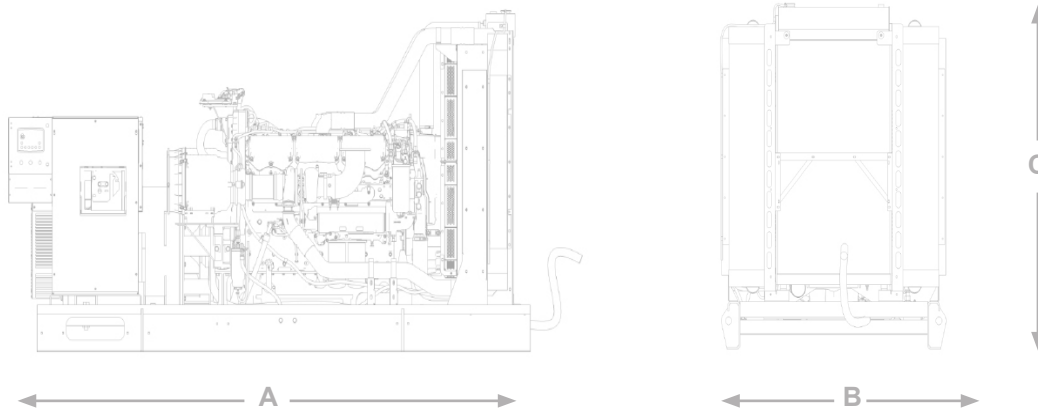

Model	Dim "A" mm (in)	Dim "B" mm (in)	Dim "C" mm (in)	Wet Weight kg (lb)
D800 GC	4175 (164.3)	1856 (73.1)	2217.5 (87.3)	6212 (13695)

Note: For reference only. Do not use for installation design. Contact your local Cat dealer for precise weights and dimensions.

Ratings and Definitions

Standby

Output available with varying load for the duration of the interruption of the normal source power. Average power output is 70% of the standby power rating. Typical operation is 200 hours per year, with maximum expected usage of 500 hours per year.

Applicable Codes and Standards

CSA C22.2 No. 100-14, UL 142, UL 489, UL 869A, UL 2200, IBC 2018, ISO 3046, ISO 8528 and facilitates compliance to NFPA37, NFPA70, NFPA99 and NFPA110 codes

Note: Codes may not be available in all model configurations. Please consult your local Cat dealer for availability.

Fuel Rates

Fuel rates are based on fuel oil of 35° API [16°C (60°F)] gravity having an LHV of 42,780 kJ/kg (18,390 Btu/lb) when used at 29°C (85°F) and weighing 838.9 g/liter (7.001 lbs/U.S. gal.).

www.cat.com/electricpower

©2022 Caterpillar
All rights reserved.

Materials and specifications are subject to change without notice.

LET'S DO THE WORK.™

The International System of Units (SI) is used in this publication. CAT, CATERPILLAR, LET'S DO THE WORK, their respective logos, "Caterpillar Corporate Yellow", the "Power Edge" and Cat "Modern Hex" trade dress as well as corporate and product identity used herein, are trademarks of Caterpillar and may not be used without permission.

GENERATOR DATA**JUNE 16, 2023****(AT400240)-ENGINE (BAA126422A)-CEM**For Help Desk Phone Numbers [Click here](#)**Selected Model**

Engine: C27 **Generator Frame:** E3835L4 **Genset Rating (kW):** 800.0 **Line Voltage:** 480
Fuel: Diesel **Generator Arrangement:** 5986006 **Genset Rating (kVA):** 1000.0 **Phase Voltage:** 277
Frequency: 60 **Excitation Type:** Internal Excitation **Pwr. Factor:** 0.8 **Rated Current:** 1202.8
Duty: STANDBY **Connection:** PARALLEL STAR **Application:** EPG **Status:** Current

Version: 20236 /20236 /20236 /677651

Spec Information

Generator Specification			Generator Efficiency		
Frame: E3835L4	Type: SR500	No. of Bearings: 1	Per Unit Load	kW	Efficiency %
Winding Type: RANDOM WOUND Flywheel: 18.0			0.25	200.0	92.8
Connection: PARALLEL STAR Housing: 0			0.5	400.0	94.4
Phases: 3 No. of Leads: 12			0.75	600.0	95.6
Poles: 4			1.0	800.0	95.9
Sync Speed: 1800 Generator Pitch: 0.6667					

Reactances	Per Unit	Ohms
SUBTRANSIENT - DIRECT AXIS X''_d	0.0668	0.0154
SUBTRANSIENT - QUADRATURE AXIS X''_q	0.1658	0.0382
TRANSIENT - SATURATED X'_d	0.1415	0.0326
SYNCHRONOUS - DIRECT AXIS X_d	3.8620	0.8898
SYNCHRONOUS - QUADRATURE AXIS X_q	1.3199	0.3041
NEGATIVE SEQUENCE X_2	0.1163	0.0268
ZERO SEQUENCE X_0	0.0382	0.0088

Time Constants	Seconds
OPEN CIRCUIT TRANSIENT - DIRECT AXIS T'_{d0}	8.3000
SHORT CIRCUIT TRANSIENT - DIRECT AXIS T'_d	0.2340
OPEN CIRCUIT SUBTRANSIENT - DIRECT AXIS T''_{d0}	0.0360
SHORT CIRCUIT SUBTRANSIENT - DIRECT AXIS T''_d	0.0170
ARMATURE SHORT CIRCUIT T_a	0.0220

Short Circuit Ratio: 0.3683

Stator Resistance = 0.009 Ohms

Field Resistance = 2.3 Ohms

Voltage Regulation		Generator Excitation	
Voltage level adjustment: +/-	5.0%	No Load	Full Load, (rated) pf Series
Voltage regulation, steady state: +/-	0.5%	Excitation voltage:	11.69 Volts 39.0 Volts
Voltage regulation with 3% speed change: +/-	0.5%	Excitation current	1.1 Amps 3.67 Amps
Waveform deviation line - line, no load: less than	2.0%		
Telephone influence factor: less than	40		

Selected Model

Engine: C27 **Generator Frame:** E3835L4 **Genset Rating (kW):** 800.0 **Line Voltage:** 480
Fuel: Diesel **Generator Arrangement:** 5986006 **Genset Rating (kVA):** 1000.0 **Phase Voltage:** 277
Frequency: 60 **Excitation Type:** Internal Excitation **Pwr. Factor:** 0.8 **Rated Current:** 1202.8
Duty: STANDBY **Connection:** PARALLEL STAR **Application:** EPG **Status:** Current

Version: 20236 /20236 /20236 /677651

Generator Mechanical Information

Center of Gravity		
Dimension X	-650.0 mm	-25.6 IN.
Dimension Y	0.0 mm	0.0 IN.
Dimension Z	0.0 mm	0.0 IN.

- "X" is measured from driven end of generator and parallel to rotor. Towards engine fan is positive. See General Information for details
- "Y" is measured vertically from rotor center line. Up is positive.
- "Z" is measured to left and right of rotor center line. To the right is positive.

Generator WT = 2140 kg	* Rotor WT = 809 kg	* Stator WT = 1081 kg
4,718 LB	1,784 LB	2,383 LB

Rotor Balance = 0.016 mm deflection PTP
Overspeed Capacity = 125% of synchronous speed

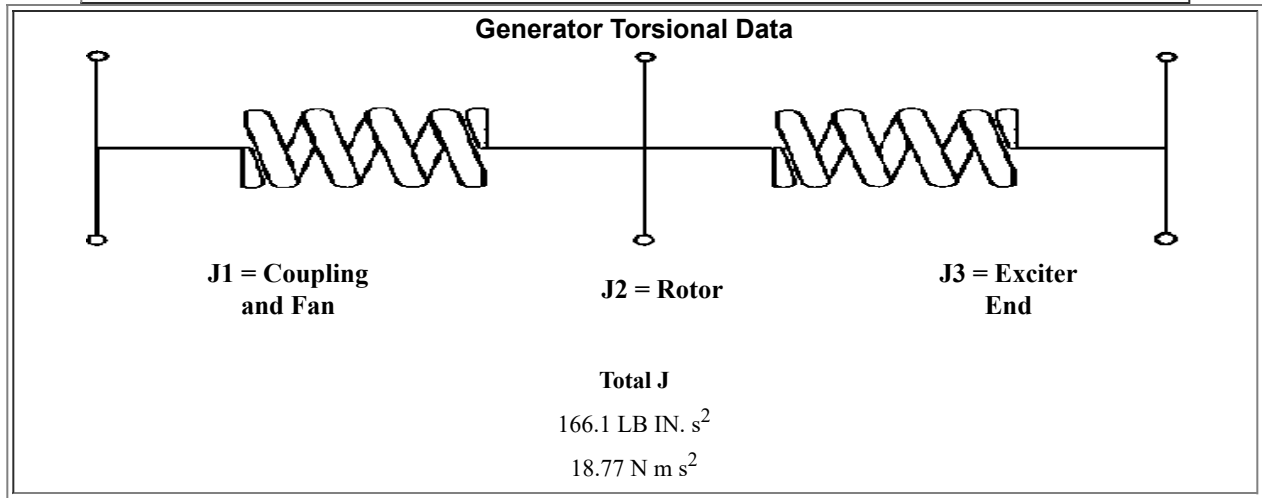

Selected Model

Engine: C27	Generator Frame: E3835L4	Genset Rating (kW): 800.0	Line Voltage: 480
Fuel: Diesel	Generator Arrangement: 5986006	Genset Rating (kVA): 1000.0	Phase Voltage: 277
Frequency: 60	Excitation Type: Internal Excitation	Pwr. Factor: 0.8	Rated Current: 1202.8
Duty: STANDBY	Connection: PARALLEL STAR	Application: EPG	Status: Current

Version: 20236 /20236 /20236 /677651

Generator Cooling Requirements - Temperature - Insulation Data	
Cooling Requirements:	Temperature Data: (Ambient 40 °C)
Heat Dissipated: 34.0 kW	Stator Rise: 105.0 °C
Air Flow: 108.0 m ³ /min	Rotor Rise: 105.0 °C
Insulation Class: H	
Insulation Reg. as shipped: 100.0 MΩ minimum at 40 °C	
Thermal Limits of Generator	
Frequency:	60 Hz
Line to Line Voltage:	480 Volts
B BR 80/40	893.0 kVA
F BR -105/40	1020.0 kVA
H BR - 125/40	1116.0 kVA
H PR - 150/40	1170.0 kVA

Selected Model

Engine: C27	Generator Frame: E3835L4	Genset Rating (kW): 800.0	Line Voltage: 480
Fuel: Diesel	Generator Arrangement: 5986006	Genset Rating (kVA): 1000.0	Phase Voltage: 277
Frequency: 60	Excitation Type: Internal Excitation	Pwr. Factor: 0.8	Rated Current: 1202.8
Duty: STANDBY	Connection: PARALLEL STAR	Application: EPG	Status: Current

Version: 20236 /20236 /20236 /677651

**Starting Capability & Current Decrement
Motor Starting Capability (0.6 pf)**

SKVA	Percent Volt Dip
196	2.5
378	5.0
571	7.5
753	10.0
945	12.5
1,145	15.0
1,354	17.5
1,578	20.0
1,811	22.5
2,090	25.0
2,427	27.5
2,788	30.0
3,277	32.5
3,800	35.0
4,297	37.5
4,788	40.0

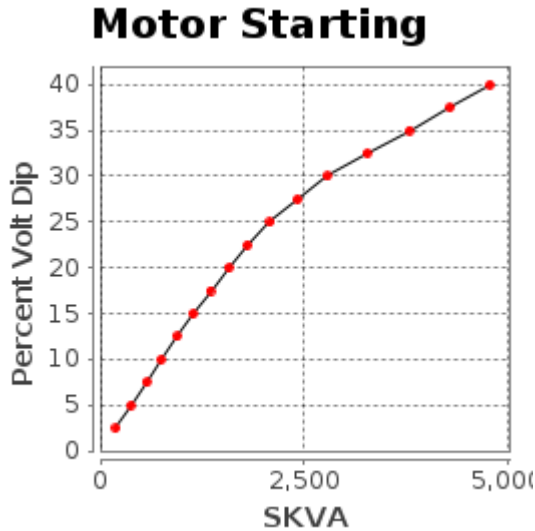

Current Decrement Data

E Time Cycle	AMP
0.0	14,931
1.0	9,774
2.0	7,722
3.0	6,842
4.0	6,413
5.0	6,162
8.0	5,791
10.0	5,545
13.0	5,313
15.0	5,159
20.0	4,928
25.0	4,797
30.0	4,726
35.0	4,691
40.0	4,678
45.0	4,678

Current Decrement

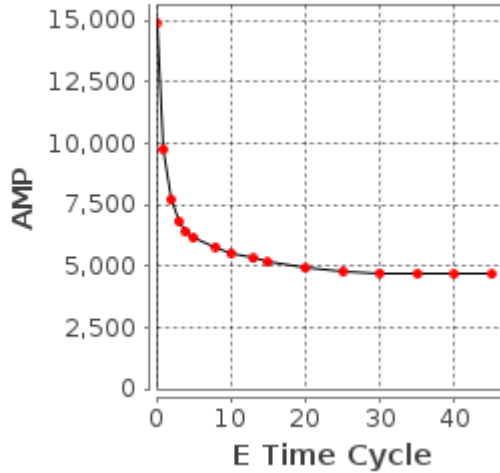

Instantaneous 3 Phase Fault Current: 17994 Amps

Instantaneous Line - Line Fault Current: 12990 Amps

Instantaneous Line - Neutral Fault Current: 19411 Amps

Selected Model

Engine: C27	Generator Frame: E3835L4	Genset Rating (kW): 800.0	Line Voltage: 480
Fuel: Diesel	Generator Arrangement: 5986006	Genset Rating (kVA): 1000.0	Phase Voltage: 277
Frequency: 60	Excitation Type: Internal Excitation	Pwr. Factor: 0.8	Rated Current: 1202.8
Duty: STANDBY	Connection: PARALLEL STAR	Application: EPG	Status: Current

Version: 20236 /20236 /20236 /677651

Reactive Capability Curve

Operating Chart

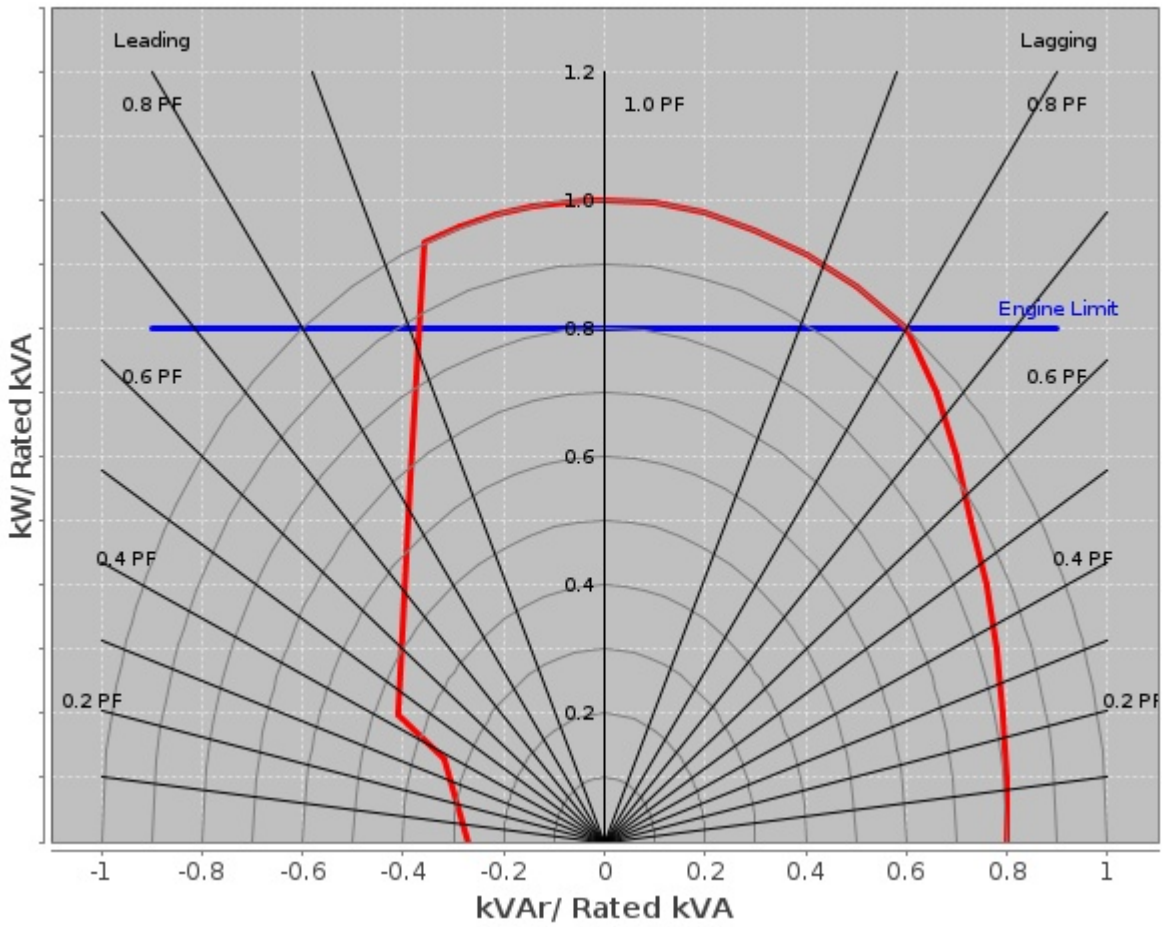

Selected Model

Engine: C27	Generator Frame: E3835L4	Genset Rating (kW): 800.0	Line Voltage: 480
Fuel: Diesel	Generator Arrangement: 5986006	Genset Rating (kVA): 1000.0	Phase Voltage: 277
Frequency: 60	Excitation Type: Internal Excitation	Pwr. Factor: 0.8	Rated Current: 1202.8
Duty: STANDBY	Connection: PARALLEL STAR	Application: EPG	Status: Current

Version: 20236 /20236 /20236 /677651

General Information

DM7802

GENERATOR GENERAL INFORMATION

I. GENERATOR MOTOR STARTING CAPABILITY CURVES

A. THE MOTOR STARTING CURVES ARE REPRESENTATIVE OF THE DATA OBTAINED BY THE FOLLOWING PROCEDURE:

1. THE CATERPILLAR GENERATOR IS DRIVEN BY A SYNCHRONOUS DRIVER.
2. VARIOUS SIZE THREE PHASE INDUCTION MOTORS (NEMA CODE F) ARE STARTED ACROSS THE LINE LEADS OF THE UNLOADED GENERATOR.
3. THE RESULTING VOLTAGE DIPS ARE RECORDED WITH AN OSCILLOSCOPE.
4. MOTOR HORSEPOWER HAS BEEN CONVERTED TO STARTING KILOVOLT AMPERES (SKVA).
5. RECORDED VOLTAGE DIPS HAVE BEEN EXPRESSED AS A OF GENERATOR RATED VOLTAGE.

II. USE OF THE MOTOR STARTING CAPABILITY CURVES.

A. CALCULATE THE SKVA REQUIRED BY THE MOTOR FOR FULL VOLTAGE STARTING ACROSS THE LINE IF THE VALUE IS NOT LISTED ON THE MOTOR DATA PLATE.

1. MOTORS CONFORMING TO NEMA STANDARDS

MULTIPLY THE MOTOR HORSEPOWER BY THE NEMA SKVA/HP FIGURE. FOR NEMA CODE F, USE 5.3 SKVA/HP; FOR NEMA CODE G, USE 6.0 SKVA/HP.

2. ALL OTHER MOTORS:

MULTIPLY THE RATED VOLTAGE BY THE LOCKED ROTOR AMPERE AND BY 0.001732. (IF THE LOCKED ROTOR AMPERES ARE NOT LISTED, MULTIPLY THE FULL LOAD (RUNNING) AMPERES BY B. USE THE ABOVE SKVA WITH THE MOTOR STARTING TABLE.

1. ACROSS LINE STARTING:

READ ACROSS THE ROW OF "ACROSS THE LINE STARTING SKVA IF THE DESIRED VALUE OF SKVA IS NOT GIVEN, CALCULATE THE DIP BY FINDING THE PROPER SKVA INTERVAL AND INTERPOLATING AS FOLLOWS:

SKVA1 IS THE SKVA TABLE ENTRY JUST SMALLER THAN THE DESIRED SKVA, DIP1 IS THE DIP FOR SKVA2, AND SKVA2 IS THE SKVA TABLE ENTRY JUST GREATER THAN THE DESIRED SKVA. THE DIP (IN PERCENT) AT THE DESIRED SKVA IS:

$$\text{DIP} = \text{DIP1} + (\text{SKVA} - \text{SKVA1}) * 2.5 / (\text{SKVA2} - \text{SKVA1})$$

NOTE: VOLTAGE DIPS GREATER THAN 35% MAY CAUSE MAGNETIC CONTACTORS TO DROP OUT.

2. REDUCED VOLTAGE STARTING:

REFER TO THE FOLLOWING TABLE. MULTIPLY THE CALCULATE ACROSS LINE SKVA BY THE MULTIPLIER LISTED FOR THE SPECIFIC STARTING METHOD. APPLY THE RESULT TO THE STARTING TABLE AS IN II A, TO CALCULATE THE EXPECTED VOLTAGE DIP:

TYPE OF REDUCED VOLTAGE STARTING	MULTIPLY LINE SKVA BY
80% TAP	.80
65% TAP	.65
50% TAP	.50
45% TAP	.45
Wye start, delta run	.33

AUTOTRANSFORMER

80% TAP	.68
65% TAP	.46
50% TAP	.29

NOTE: REDUCE VOLTAGE STARTING LOWERS THE MAXIMUM REQUIRED MOTOR skVA.

3. Part winding starting:

Most common is half-winding start, full-winding run.

Multiply the full motor, across line starting skVA by 0.6. Apply the result to the selected curve as in ii. A above. Read the expected voltage dip, for the required skVA.

III. DEFINITION:

A. GENERATOR TERMS

MODEL: Engine Sales model

ENG TYPE: DI = Direct Injection,

NA = Naturally aspirated, etc

HZ: Running frequency, hertz

RATING TYPE: PP, SB (prime power or standby)

KW: Base rating electrical kilowatts (ekW)

VOLTS: Rating terminal, line to line

GEN ARR: Cat generator arrangement part number

GEN FRAME: Generator frame size designation

CONN: Generator output connection

(star, wye, delta, ect.)

POLES: Number of pole pieces on rotor.

(eg. A 4 pole generator run at 1800)

RPM will produce 60 Hz alternating current. A 6 pole generator run at 1200 RPM will produce 60 Hz alternating current.)

B. GENERATOR TEMPERATURE RISE:

The indicated temperature rise indicated the NEMA limits for standby or prime power applications. These rises are used for calculating the losses and efficiencies and are not necessarily indicative of the actual temperature rise of a given machine.

C. CENTER OF GRAVITY

The specified center of gravity is for the generator only.

For single bearing, and two bearing close coupled generators, the center of gravity is measured from the generator/engine flywheel housing interface and from the centerline of the rotor shaft.

For two bearing, standalone generators, the center of gravity is measured from the end of the rotor shaft and from the centerline of the rotor shaft.

For two bearing, standalone generators, the center of gravity is measured from the end of the rotor shaft and from the centerline of the rotor shaft.

D. GENERATOR DECREMENT CURRENT CURVES

The generator decrement current curve gives the symmetrical current supplied by the generator for a three phase bolted fault at the generator terminals. Generators equipped with the series boost attachment or generators with PM excitation system will supply 300% of rated current for at least 10 seconds.

E. GENERATOR EFFICIENCY CURVES

The efficiency curve is representative of the overall generator efficiency over the normal range of the electrical load and at the specified parameters. This is not the overall engine generator set efficiency curve.

Caterpillar Confidential: **Green**

Content Owner: Commercial Processes Division

Web Master(s): [PSG Web Based Systems Support](#)

Current Date: 6/16/2023, 4:54:24 PM

© Caterpillar Inc. 2023 All Rights Reserved.

[Data Privacy Statement](#).

PERFORMANCE DATA [DM7696]

JUNE 16, 2023

For Help Desk Phone Numbers [Click here](#)

Perf No: DM7696

Change Level: 04

[General](#)
 [Heat Rejection](#)
 [Emissions](#)
 [Regulatory](#)
 [Altitude Derate](#)
 [Cross Reference](#)
 [Perf Param Ref](#)

[View PDF](#)

SALES MODEL:	C27	COMBUSTION:	DIRECT INJECTION
BRAND:	CAT	ENGINE SPEED (RPM):	1,800
MACHINE SALES MODEL:		HERTZ:	60
ENGINE POWER (BHP):	1,214	FAN POWER (HP):	39.3
GEN POWER WITH FAN (EKW):	800.0	ASPIRATION:	TA
COMPRESSION RATIO:	16.5	AFTERCOOLER TYPE:	ATAAC
RATING LEVEL:	STANDBY	AFTERCOOLER CIRCUIT TYPE:	JW+OC, ATAAC
PUMP QUANTITY:	1	INLET MANIFOLD AIR TEMP (F):	120
FUEL TYPE:	DIESEL	JACKET WATER TEMP (F):	210.2
MANIFOLD TYPE:	DRY	TURBO CONFIGURATION:	PARALLEL
GOVERNOR TYPE:	ADEM4	TURBO QUANTITY:	2
ELECTRONICS TYPE:	ADEM4	TURBOCHARGER MODEL:	GTA5008BS-56T-1.60
IGNITION TYPE:	CI	CERTIFICATION YEAR:	2010
INJECTOR TYPE:	EUI	PISTON SPD @ RATED ENG SPD (FT/MIN):	1,800.0
REF EXH STACK DIAMETER (IN):	10		
MAX OPERATING ALTITUDE (FT):	7,999		

INDUSTRY	SUB INDUSTRY	APPLICATION
ELECTRIC POWER	STANDARD	PACKAGED GENSET
OIL AND GAS	LAND PRODUCTION	PACKAGED GENSET

General Performance Data [Top](#)

GENSET POWER WITH FAN	PERCENT LOAD	ENGINE POWER	BRAKE MEAN EFF PRES (BMEP)	BRAKE SPEC FUEL CONSUMPTN (BSFC)	ISO BRAKE SPEC FUEL CONSUMPTN (BSFC)	VOL FUEL CONSUMPTN (VFC)	ISO VOL FUEL CONSUMPTN (VFC)
EKW	%	BHP	PSI	LB/BHP-HR	LB/BHP-HR	GAL/HR	GAL/HR
800.0	100	1,190	318	0.331	0.323	55.6	54.3
720.0	90	1,073	286	0.335	0.327	50.7	49.5
640.0	80	957	255	0.340	0.332	45.9	44.8
600.0	75	900	240	0.342	0.334	43.4	42.3
560.0	70	842	225	0.343	0.335	40.7	39.8
480.0	60	728	194	0.345	0.337	35.4	34.6
400.0	50	615	164	0.346	0.338	30.0	29.3
320.0	40	504	135	0.350	0.342	24.9	24.3
240.0	30	393	105	0.358	0.350	19.9	19.4
200.0	25	337	90	0.364	0.356	17.3	16.9
160.0	20	280	75	0.375	0.366	14.8	14.5
80.0	10	162	43	0.435	0.424	9.9	9.7

GENSET POWER WITH FAN	PERCENT LOAD	ENGINE POWER	INLET MFLD PRES	INLET MFLD TEMP	EXH MFLD TEMP	EXH MFLD PRES	ENGINE OUTLET TEMP	COMPRESSOR OUTLET PRES	COMPRESSOR OUTLET TEMP
EKW	%	BHP	IN-HG	DEG F	DEG F	IN-HG	DEG F	IN-HG	DEG F
800.0	100	1,190	57.6	119.1	1,222.8	40.4	947.8	60	358.0
720.0	90	1,073	52.4	114.5	1,188.5	36.5	928.9	55	336.7
640.0	80	957	46.8	113.1	1,161.4	32.2	916.5	49	314.8
600.0	75	900	43.7	112.4	1,146.4	29.8	909.6	46	302.1

GENSET POWER WITH FAN	PERCENT LOAD	ENGINE POWER	INLET MFLD PRES	INLET MFLD TEMP	EXH MFLD TEMP	EXH MFLD PRES	ENGINE OUTLET TEMP	COMPRESSOR OUTLET PRES	COMPRESSOR OUTLET TEMP
560.0	70	842	40.0	110.4	1,127.0	27.3	899.9	42	285.8
480.0	60	728	32.3	105.7	1,078.4	22.3	873.1	34	253.8
400.0	50	615	24.7	100.8	1,016.5	17.4	836.5	26	222.4
320.0	40	504	18.1	97.0	935.5	13.5	782.1	19	192.2
240.0	30	393	12.4	93.9	835.3	10.2	709.3	13	162.3
200.0	25	337	9.7	92.6	777.5	8.8	665.6	11	147.3
160.0	20	280	7.4	91.9	713.5	7.6	615.6	8	133.7
80.0	10	162	3.9	92.8	564.1	5.7	492.7	5	114.1

GENSET POWER WITH FAN	PERCENT LOAD	ENGINE POWER	WET INLET AIR VOL FLOW RATE	ENGINE OUTLET WET EXH GAS VOL FLOW RATE	WET INLET AIR MASS FLOW RATE	WET EXH GAS MASS FLOW RATE	WET EXH VOL FLOW RATE (32 DEG F AND 29.98 IN HG)	DRY EXH VOL FLOW RATE (32 DEG F AND 29.98 IN HG)
EKW	%	BHP	CFM	CFM	LB/HR	LB/HR	FT3/MIN	FT3/MIN
800.0	100	1,190	2,200.4	5,943.3	9,469.4	9,863.6	2,076.2	1,881.0
720.0	90	1,073	2,097.2	5,567.7	9,001.3	9,361.3	1,971.4	1,791.5
640.0	80	957	1,963.0	5,142.0	8,402.0	8,727.5	1,837.1	1,673.5
600.0	75	900	1,885.5	4,904.2	8,059.1	8,366.8	1,760.9	1,606.0
560.0	70	842	1,799.8	4,638.3	7,681.5	7,970.5	1,677.4	1,531.7
480.0	60	728	1,618.3	4,074.9	6,886.8	7,138.0	1,503.3	1,376.0
400.0	50	615	1,433.7	3,494.4	6,083.9	6,296.9	1,325.5	1,216.1
320.0	40	504	1,270.3	2,963.8	5,377.5	5,554.2	1,173.5	1,081.6
240.0	30	393	1,120.0	2,452.2	4,733.6	4,874.4	1,031.4	956.7
200.0	25	337	1,049.0	2,200.7	4,431.9	4,554.8	961.6	895.5
160.0	20	280	985.8	1,964.5	4,163.7	4,268.7	898.3	840.7
80.0	10	162	894.5	1,565.5	3,772.7	3,843.3	808.2	766.0

Heat Rejection Data [Top](#)

GENSET POWER WITH FAN	PERCENT LOAD	ENGINE POWER	REJECTION TO JACKET WATER	REJECTION TO ATMOSPHERE	REJECTION TO EXH	EXHAUST RECOVERY TO 350F	FROM OIL COOLER	FROM AFTERCOOLER	WORK ENERGY	LOW HEAT VALUE ENERGY	HIGH HEAT VALUE ENERGY
EKW	%	BHP	BTU/MIN	BTU/MIN	BTU/MIN	BTU/MIN	BTU/MIN	BTU/MIN	BTU/MIN	BTU/MIN	BTU/MIN
800.0	100	1,190	18,779	5,849	44,601	25,213	6,438	9,057	50,481	120,880	128,767
720.0	90	1,073	17,808	4,992	41,200	23,106	5,876	8,008	45,509	110,318	117,517
640.0	80	957	16,691	4,461	37,677	21,034	5,311	6,786	40,598	99,707	106,213
600.0	75	900	15,607	4,786	35,758	19,900	5,022	6,124	38,160	94,283	100,435
560.0	70	842	14,638	4,988	33,616	18,603	4,718	5,397	35,720	88,579	94,359
480.0	60	728	13,512	4,464	29,060	15,798	4,100	4,083	30,880	76,976	81,999
400.0	50	615	11,598	4,504	24,410	12,913	3,477	2,962	26,073	65,288	69,549
320.0	40	504	10,383	3,959	19,934	10,055	2,886	2,050	21,390	54,180	57,716
240.0	30	393	9,677	2,739	15,613	7,277	2,301	1,296	16,686	43,193	46,011
200.0	25	337	9,195	2,146	13,533	5,943	2,007	969	14,304	37,688	40,147
160.0	20	280	8,507	1,714	11,540	4,657	1,717	697	11,882	32,236	34,340
80.0	10	162	6,156	1,807	7,874	2,218	1,152	322	6,882	21,629	23,040

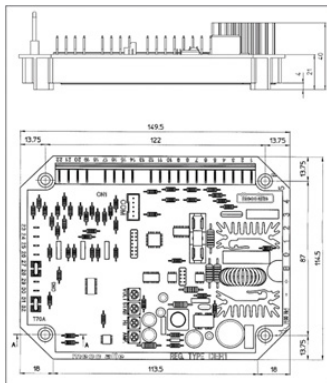

Image shown might not reflect actual configuration

Technical Specifications

Maximum current	5A (Continuous)
Forced excitation current for 1 minute	10A
Power Input (Aux winding or PMG)	Voltage: 40Vac to 270Vac
	Frequency: 12Hz to 72Hz
Sensing voltage	Range 1: 75Vac to 150Vac
	Range 2: 150Vac to 300Vac
Voltage Regulation (Steady state)	<±0.54%
Analog input (A1-A2)	0Vdc - 2.5V dc
	-10Vdc to +10Vdc
External Volts Adjustment	±10% with 100k ohm Pot
Operating temperature:	-25°C to +70°C
Dimensions (L x W x H)	149.5mm x 114.5mm x 40mm

DER1- Automatic Voltage Regulator

The DER1 is a voltage regulator for 50 or 60 Hz synchronous alternators Internally excited brushless type SR500 frame generators. The AVR circuitry includes under speed and overload protection.

Features

- All parameters on the AVR can be programmed using a USB connector and a computer or through potentiometers
- Genset output voltage can be altered by adjusting the onboard potentiometer “VOLT”
- Onboard overload setting can be altered by adjusting the onboard potentiometer “AMP” which allows the user to set the overload limit and has LED indication to show overload condition & Protection activated* (after time delay)
- “HZ” potentiometer adjusts the under speed protection with respect to the nominal speed value set by the 50/60 hz jumper
- “STAB” potentiometer adjusts the dynamic response of the alternator under transient response
- Remote control of voltage available with a range of 0Vdc to 2.5Vdc or -10Vdc to +10Vdc.

*flash rate varies in each protection activated!

www.cat.com/electricpower

©2021 Caterpillar

All rights reserved.

Materials and specifications are subject to change without notice.

The International System of Units (SI) is used in this publication.

LET'S DO THE WORK.™

LEHE20369-00 (09/21)

CAT, CATERPILLAR, LET'S DO THE WORK, their respective logos, "Caterpillar Corporate Yellow," the "Power Edge" and Cat "Modern Hex" trade dress as well as corporate and product identity used herein, are trademarks of Caterpillar and may not be used without permission.



ADEM™ A4 Engine Controller

The ADEM™ A4 is the main Electronic Control Module (ECM) used on select diesel engines. The ADEM A4 provides a higher degree of control over a large number of combustion variables. The ADEM A4 is designed to control/interface Electronic Unit Injector (EUI) equipped engines. The ADEM A4 engine system is composed of the ADEM A4 ECM, control software, sensors, actuators, fuel injectors, and interface to the generator system. The prime benefit of an ADEM A4 engine system is to better control and maintain the particulate emissions, both steady state and transient, while improving engine performance.

Features

Reliable, Durable

All ADEM A4 controllers are designed to survive the harshest environments.

- Environmentally sealed, die-cast aluminum housing isolates and protects electronic components from moisture and dirt contamination
- Rigorous vibration testing ensures product reliability and durability
- Accuracy maintained from -40°C to 85°C
- Electrical noise immunity to 100 volts / meter
- Internal circuits are designed to withstand shorts to + battery and – battery

Simple Servicing

Each ADEM A4 system works in combination with the Cat® ET service tool software to keep the engine operating at peak performance.

- Displays measured parameters
- Retrieves active and logged event code documenting abnormal system operation
- Performs calibrations and diagnostic tests
- Supports flash programming of new software into the ADEM A4 ECM

Self Diagnostics

Each ADEM A4 ECM has a full compliment of diagnostics. The ECM can detect faults in the electrical system and report those faults to the service technician for quick repair.

- Self-diagnostic capability pinpoints operational problems in need of attention.

Advanced Features

- Enhanced performance from fuel injection timing and limiting
- Adjustable monitoring of vital engine parameters
- Programmable speed acceleration ramp rate
- Data link interfaces

Description

The ECM is housed in an environmentally sealed cast-ing. All wiring connections to the ECM are made using two sealed connectors: a single seventy-pin connector and a single one hundred twenty-pin connector.

Engine Speed Governing

Desired engine speed is calculated by the ECM and held within ± 0.2 Hz for isochronous and droop mode. The ECM accounts for droop that is requested. The proper amount of fuel is sent to the injectors due to these calculations. The ECM also employs cooldown/shutdown strategies, acceleration delays on startup, acceleration ramp times and speed reference.

Fuel Limiting

Warm and cold fuel-air ratio control limits are controlled by the ECM. Electronic monitoring system derates, torque limit, and cranking limit, programmable torque scaling, and cold cylinder cutout mode are standard features.

Fuel Injection Timing

Master timing for injection is controlled by the ECM control. Temperature dependencies are accounted for in the fuel injection calculations.

Electronic Monitoring

Electronic monitoring of vital engine parameters can be programmed. Warning, derate, and shutdown event conditions may be customized by the user.

Information Management

The ECM stores information to assist with electronic troubleshooting. Active and logged diagnostic codes, active events, logged events, fuel consumption, engine hours, and instantaneous totals aid service technicians when diagnosing electronic faults and scheduling preventive maintenance.

Calibrations

Engine performance is optimized through injection timing. Auto/manual sensor calibrations are standard features.

On-Board System Tests

System tests are available to assist in electronic troubleshooting. These tests include: injector activation, injector cutout, and override of control outputs.

Data Link Interfaces

The ADEM A4 communicates with the EMCP via a dedicated communication network.

Electronic Sensing

The following sensing is available on the ADEM A4: oil pressure, fuel pressure, fuel temperature, atmospheric pressure, air inlet temperature, turbo outlet pressure, engine coolant temperature, engine speed, throttle, position, exhaust temperature, oil filter pressure differential, fuel filter pressure differential, air filter pressure differential and crankcase pressure.

SPECIFICATIONS

Impervious to:

Salt spray, fuel, oil and oil additives, coolant, spray cleaners, chlorinated solvents, hydrogen sulfide and methane gas, and dust.

Input and output protection

All inputs and outputs are protected against short circuits to +battery and –battery

Input voltage range (24 VDC nominal)

18 to 32 VDC

Mounting

Engine mounted

Reverse polarity protected

Shock, withstands 20g

Temperature range

Operating: –40°C to 85°C (–40°F to 185°F)

Storage: –50°C to 120°C (–58°F to 248°F)

Vibration

Withstands 8.0g @ 24 to 2 kHz

Information contained in this publication may be considered confidential. Discretion is recommended when distributing. Materials and specifications are subject to change without notice.

CAT, CATERPILLAR, LET'S DO THE WORK, their respective logos, "Caterpillar Yellow," the "Power Edge" and Cat "Modern Hex" trade dress as well as corporate and product identity used herein, are trademarks of Caterpillar and may not be used without permission.



Image shown might not reflect actual configuration

GCCP 1.2 - Control Panel

GCCP 1.2 is an auto Start Control Module suitable for a wide variety of diesel gen-set applications. Monitoring an extensive number of engine parameters, the modules will display warnings, shutdown and engine status information on the backlit LCD screen, illuminated LEDs and remote PC.

FEATURES

- 4-line back-lit LCD text display
- Multiple display languages
- Five-key menu navigation
- LCD alarm indication
- Customisable power-up text and images
- Data logging facility
- Internal PLC editor
- Protections disable feature
- Fully configurable via PC using USB & RS485 communication
- Front panel configuration with PIN protection
- Power save mode
- 3-phase generator sensing and protection
- Generator current and power monitoring (kW, kvar, kVA, pf)
- kW and kvar overload and reverse power alarms
- Over current protection
- Unbalanced load protection
- Breaker control via fascia buttons
- Fuel and start outputs configurable when using CAN Support for 0 V to 10 V & 4 mA to 20 mA sensors
- 8 configurable digital inputs (3 available for Customer use)
- 8 configurable digital outputs (5 available for Customer use)
- 4 configurable analogue inputs (3 available for Customer Use)
- CAN, MPU and alternator frequency speed sensing in one variant
- Real time clock
- Engine pre-heat and post-heat functions
- Engine run-time scheduler
- Engine idle control for starting & stopping
- Fuel usage monitor and low fuel level alarms
- 3 configurable maintenance alarms

BENEFITS

- Hours counter provides accurate information for monitoring and maintenance periods
- User-friendly set-up and button layout for ease of use
- Multiple parameters are monitored & displayed simultaneously for full visibility
- The module can be configured to suit a wide range of applications for user flexibility
- PLC editor allows user configurable functions to meet user specific application requirements.
- RS485 Communication port can be used for the Remote Monitoring Communication (Compatible with Cat PLG)

SPECIFICATION

DC SUPPLY

CONTINUOUS VOLTAGE RATING

8 V to 35 V Continuous
5 V for upto 1 minute

CRANKING DROPOUTS

Able to survive 0 V for 100 ms, providing supply was at least 10 V before dropout and supply recovers to 5 V. This is achieved without the need for internal batteries.

LEDs and backlight will not be maintained during cranking.

MAXIMUM OPERATING CURRENT

260 mA at 12 V, 150 mA at 24 V

MAXIMUM STANDBY CURRENT

145 mA at 12 V, 85 mA at 24 V

CHARGE FAIL/EXCITATION RANGE

0 V to 35 V

GENERATOR & MAINS (UTILITY) VOLTAGE RANGE

15 V to 415 V AC (Ph to N)
26 V to 719 V AC (Ph to Ph)

FREQUENCY RANGE

3.5 Hz to 75 Hz

MAGNETIC PICKUP VOLTAGE RANGE

+/- 0.5 V to 70 V

FREQUENCY RANGE

10,000 Hz (max)

INPUTS

DIGITAL INPUTS A TO H

Negative switching

ANALOGUE INPUTS A & D

Configurable as:

Negative switching digital input 0 V to 10 V sensor
4 mA to 20 mA sensor Resistive sensor

ANALOGUE INPUTS B & C

Configurable as:

Negative switching digital input Resistive sensor

OUTPUTS

OUTPUT A & B (FUEL & START)

15 A DC at supply voltage

AUXILIARY OUTPUTS C, D, E, F, G & H

2 A DC at supply voltage

DIMENSIONS OVERALL

216 mm x 158 mm x 43 mm
8.5" x 6.2" x 1.5"

PANEL CUT-OUT

184 mm x 137 mm
7.2" x 5.3"

MAXIMUM PANEL THICKNESS

8 mm
0.3"

STORAGE TEMPERATURE RANGE

-40°C to +85°C
-40 °F to +185 °F

OPERATING TEMPERATURE RANGE

-30°C to +70°C
-22 °F to +158 °F

LEHE2017-02 (09-20)

www.Cat.com/electricpower

©2020 Caterpillar All rights reserved. Materials and specifications are subject to change without notice. The International System of Units (SI) is used in this publication. CAT, CATERPILLAR, their respective logos, "Caterpillar Corporate Yellow", the "Power Edge" and Cat "Modern Hex" trade dress as well as corporate and product identity used herein, are trademarks of Caterpillar and may not be used without permission.



Image shown might not reflect actual configuration

Remote Annunciator Module

It is an LED expansion module that can be used with compatible control modules. The module has been designed to display a maximum of eight individual LED indications up to a maximum distance of 1 KM (0.6 miles).

The Annunciator will consist of two modules to provide a 16 Channel Fault annunciation.

It is presented in a vertical enclosure. It includes an alarm sounder that is triggered when the host controller detects an alarm condition. The alarm can be muted using the front push button.

The Panels will be fitted with removable label cards which can be used to identify the standard NFPA alarms. If desired

It includes individual LEDs for each channel and a 'Power On' LED that flashes when the link with the host controller is lost.

FEATURES

- The Remote annunciator has an integral Sounder / Horn
- Eight configurable LEDs (per module)
- Works up to 1 KM (0.6 miles) from the host controller
- A single Controller can support five Caterpillar Configured remote annunciator control boxes

LEHE2021-01 (03-21)

www.Cat.com/electricpower

©2021 Caterpillar All rights reserved. Materials and specifications are subject to change without notice. The International System of Units (SI) is used in this publication. CAT, CATERPILLAR, their respective logos, "Caterpillar Corporate Yellow", the "Power Edge" and Cat "Modern Hex" trade dress as well as corporate and product identity used herein, are trademarks of Caterpillar and may not be used without permission.

ENVIRONMENTAL TESTING STANDARDS

ELECTRO-MAGNETIC COMPATIBILITY

BS EN 61000-6-2
EMC Generic Immunity Standard for the Industrial Environment
BS EN 61000-6-4
EMC Generic Emission Standard for the Industrial Environment

ELECTRICAL SAFETY

BS EN 60950
Safety of Information Technology Equipment, including Electrical Business Equipment

TEMPERATURE

BS EN 60068-2-1
Ab/Ae Cold Test -30 °C BS EN 60068-2-2
Bb/Be Dry Heat +70°C

VIBRATION

BS EN 60068-2-6
Ten sweeps in each of three major axes
5 Hz to 8 Hz @ +/-7.5 mm, 8 Hz to 500 Hz @ 2 gn

SHOCK

BS EN 60068-2-27
Three shocks in each of three major axes 15 gn in 11 Ms

HUMIDITY

BS EN 60068-2-30
Db Damp Heat Cyclic 20/55 °C @ 95% RH 48 Hours
BS EN 60068-2-78
Cab Damp Heat Static 40 °C @ 93% RH 48 Hours

DEGREES OF PROTECTION PROVIDED BY ENCLOSURES BS EN 60529

IP65 - Front of module when installed into the control panel with the supplied sealing gasket.

SPECIFICATION

CONTINUOUS VOLTAGE RATING

8 V to 35 V Continuous

CRANKING DROPOUTS

Able to survive 0 V for 50 mS, providing supply was at least 10 V before dropout and supply recovers to 5 V. This is achieved without the need for internal batteries. LEDs and backlight will not be maintained during cranking.

MAXIMUM OPERATING CURRENT

112 mA at 12 V, 53 mA at 24 V

MAXIMUM STANDBY CURRENT

74 mA at 12 V, 35 mA at 24 V

DIMENSIONS OVERALL

355 mm x 369 mm x 90 mm
13.97" x 14.52" x 3.54"

PANEL CUT-OUT

286 mm x 326 mm x 93 mm
11.25" x 12.83" x 3.66"

MAXIMUM PANEL THICKNESS

8 mm
0.3"

Factory installed on the control panel. No contractor installation required.



Remote Emergency Stop Button

Image shown may not reflect actual configuration.

Features and Benefits

- Enclosure degree of protection – IP 69K (NEMA 6)
- UL Listed (NKCR)
- Assembled enclosure with shroud
- 40 mm mushroom emergency stop
- Twist release
- 2NC – horizontally mounted

Dimensions

- Net Width: 0.065 m
- Net Height: 0.078 m
- Net Depth: 0.065 m
- Net Weight: 0.124 kg

www.Cat-ElectricPower.com

©2020 Caterpillar

All rights reserved.

Materials and specifications are subject to change without notice.
CAT, CATERPILLAR, LET'S DO THE WORK, their respective logos, "Caterpillar Corporate Yellow", the "Power Edge" and Cat "Modern Hex" trade dress as well as corporate and product identity used herein, are trademarks of Caterpillar and may not be used without permission



L Frame



P Frame



R Frame

Molded Case Circuit Breakers

C27 – C32 North America built packages (60 Hz)

L-Frame
250A-400A (UL)

P-Frame
1200A (UL)

R-Frame
1600-2000A (UL)

Features

Design Specifications:

- Moisture and fungus protection
- Clear indication of breaker status
- Reinforced insulation
- Shunt trip
- Auxiliary contacts
- Load side extension bars
- Maintenance-free operation
- Exceptional characteristics under short-circuit conditions
- Adjustable trip settings

L-Frame

UL 489
CSA 22.2 No 5
Federal Specification W-C-375B/GEN
NEMA AB1
NMX J-266 CCC
CE Marking

P-Frame & R-Frame

UL 489
CSA 22.2 No 5-02
Federal Specification W-C-375B/GEN
NEMA AB1
NMX J-266

Standard Features

Standards

- UL-CSA
 - L-Frame
 - P-Frame
 - R-Frame

Shunt trip

- The shunt trip provides a means of tripping the circuit breaker electronically
- Shunt trip ratings
 - Voltage: 24VDC
 - Coil Burden (Holding/Inrush): 4.5/200 VA
 - Power Consumption: 4.5 VA

Auxiliary contacts

The auxiliary contacts provide a means of remote circuit breaker position indication and consists of (1) Form C Contact (1 Normally open and 1 Normally closed contact) with the following current ratings:

6A @ 240-480 VAC, 50/60 Hz

Trip units

All circuit breakers come equipped with True RMS Current Sensing.

The trip units for each of the circuit breaker ratings sample the current waveform to provide true RMS protection through the 15th harmonic. This true RMS sensing gives accurate values for the magnitude of a nonsinusoidal waveform.

Therefore, the heating effects of harmonically distorted waveforms are accurately evaluated. The trip system comes equipped with a set of current transformers (CT's) to sense current, a trip unit to evaluate the current, and a tripping solenoid to trip the circuit breaker.

Additionally, each trip unit comes equipped with Active Thermal Imaging which is active 20 minutes before and after tripping.

Customer cable connections

Extension bus bars or mechanical lugs are provided for installation of load cables.

Cat® Part Number	Frame and Rating (Amps)	IEC/UL	No. Poles	Operation	Trip Unit	Circuit Breaker Characteristics	Options	Instantaneous Override (kA RMS) +/- 10%
611-4994	250A L-Frame MCCB	UL	3	MO	3.3S LSI	Table 3	1 Aux Contact, Shunt Trip	–
421-3235	400A L-Frame MCCB	UL	3	MO	3.3S LSI	Table 3	1 Aux Contact, Shunt Trip	–
421-3237	400A L-Frame MCCB	UL	3	MO	6.3A LSIG	Table 3	1 Aux Contact, Shunt Trip	–
244-9774	1200A P-Frame MCCB	UL	3	MO	5.0A LSI	Table 1	1 Aux Contact, Shunt Trip	24
244-9864	1600A R-Frame MCCB	UL	3	MO	5.0A LSI	Table 2	1 Aux Contact, Shunt Trip	57
244-9868	2000A R-Frame MCCB	UL	3	MO	5.0A LSI	Table 2	1 Aux Contact, Shunt Trip	57
244-9778	1200A P-Frame MCCB	UL	3	MO	6.0A LSIG	Table 1	1 Aux Contact, Shunt Trip	24
244-9865	1600A R-Frame MCCB	UL	3	MO	6.0A LSIG	Table 2	1 Aux Contact, Shunt Trip	57
244-9869	2000A R-Frame MCCB	UL	3	MO	6.0A LSIG	Table 2	1 Aux Contact, Shunt Trip	57
244-9790	1200A P-Frame MCCB	UL	3	MO	6.0P LSIG-P	Table 1	1 Aux Contact, Shunt Trip, Modbus	24
585-8063	1600A R-Frame MCCB	UL	3	MO	6.0P LSIG-P	Table 2	1 Aux Contact, Shunt Trip, Modbus	57
585-8064	2000A R-Frame MCCB	UL	3	MO	6.0P LSIG-P	Table 2	1 Aux Contact, Shunt Trip, Modbus	57

Circuit Breakers Characteristics

TABLE 1

Model		P-Frame	
Number of Poles		3	
Rated Current (Amps)		1200A (UL)	
Voltage Rating (VAC)		600UL/ 690 IEC	
Interrupt Rating (UL/CSA) (60 Hz) – kA RMS		240V	65
		480V	35
		600V	18
IEC 60947-2 Rating (50/60 Hz) – kA RMS	Icu	240V	50
		380/415V	35
	Ics	240V	25
		380/415V	20

TABLE 3

Model		L-Frame	
Number of Poles		3	
Rated Current (Amps)		250A – 400A (UL)	
Voltage Rating (VAC)		600UL/ 525 IEC	
Interrupt Rating (UL/CSA) (60 Hz) – kA RMS		240V	65
		480V	35
		600V	18
IEC 647-2 Rating (50/60 Hz) – kA RMS	Icu	240V	50
		380/415V	35
	Ics	240V	25
		380/415V	20

TABLE 2

Model		R-Frame	
Number of Poles		3	
Rated Current (Amps)		1600A – 2000A (UL)	
Voltage Rating (VAC)		600UL/ 690 IEC	
Interrupt Rating (UL/CSA) (60 Hz) – kA RMS		240V	65
		480V	35
		600V	18
IEC 60947-2 Rating (50/60 Hz) – kA RMS	Icu	240V	50
		380/415V	35
	Ics	240V	25
		380/415V	20

P, R, NS-Frame Long-Short Trip Curve and NW-Frame Long-Short Trip Curve

CURRENT IN MULTIPLES OF I_r ($I_r = \text{Long-time setting} \times I_n$)

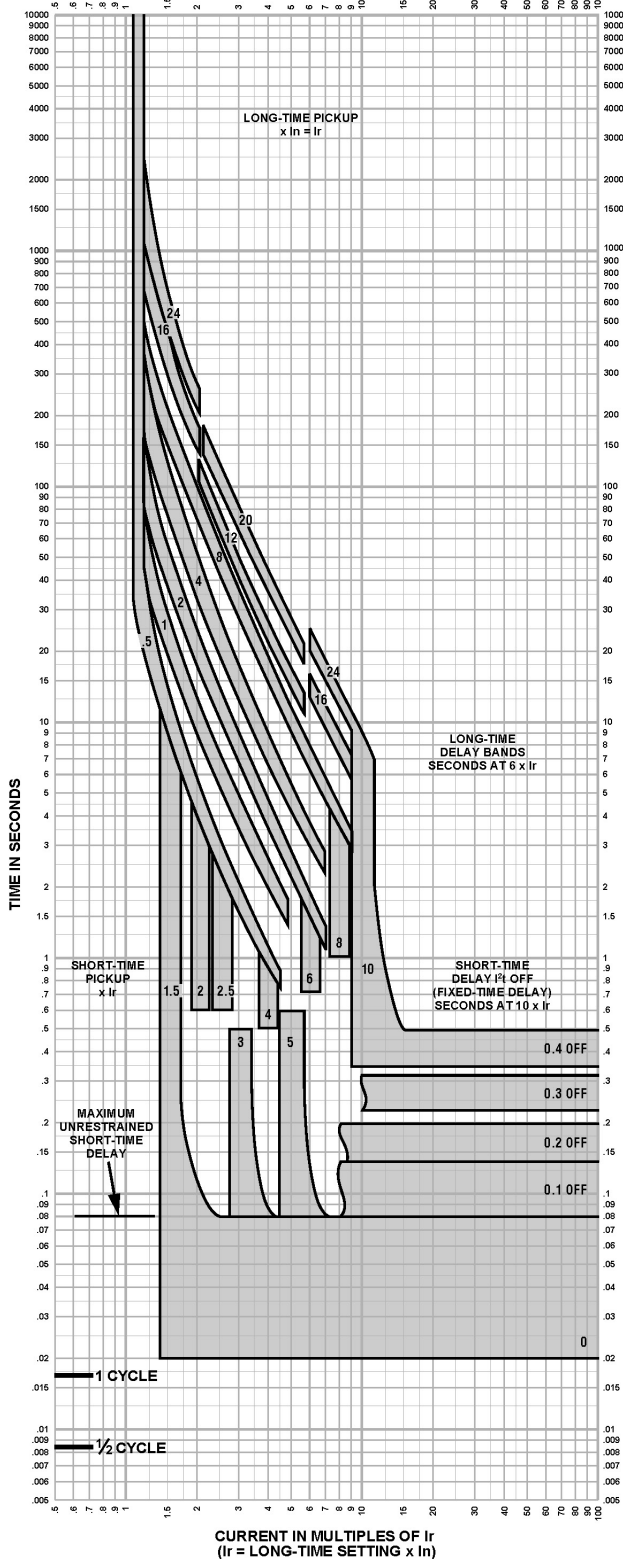

Long-time Pickup and Delay Short-time Pickup and I^2t OFF Delay

The time-current curve information is to be used for application and coordination purposes only. Curves apply from -30°C to $+60^{\circ}\text{C}$ ambient temperature.

Notes:

1. There is a thermal-imaging effect that can act to shorten the long-time delay. The thermalimaging effect comes into play if a current above the long-time delay pickup value exists for a time and then is cleared by the tripping of a downstream device or the circuit breaker itself. A subsequent overload will cause the circuit breaker to trip in a shorter time than normal. The amount of time delay reduction is inverse to the amount of time that has elapsed since the previous overload. Approximately 20 minutes is required between overloads to completely reset thermalimaging.
2. The end of the curve is determined by the interrupting rating of the circuit breaker.
3. With zone-selective interlocking on, short-time delay utilized and no restraining signal, the maximum unrestrained short-time delay time band applies regardless of the setting.
4. Total clearing times shown include the response times of the trip unit, the circuit breaker opening, and the extinction of the current.
5. For a withstand circuit breaker, instantaneous can be turned OFF.
6. Overload indicator illuminates at 100%.

P, R, NS-Frame Instant Curve and NW-Frame Instant Trip Curve

MULTIPLES OF SENSOR RATING (I_n)

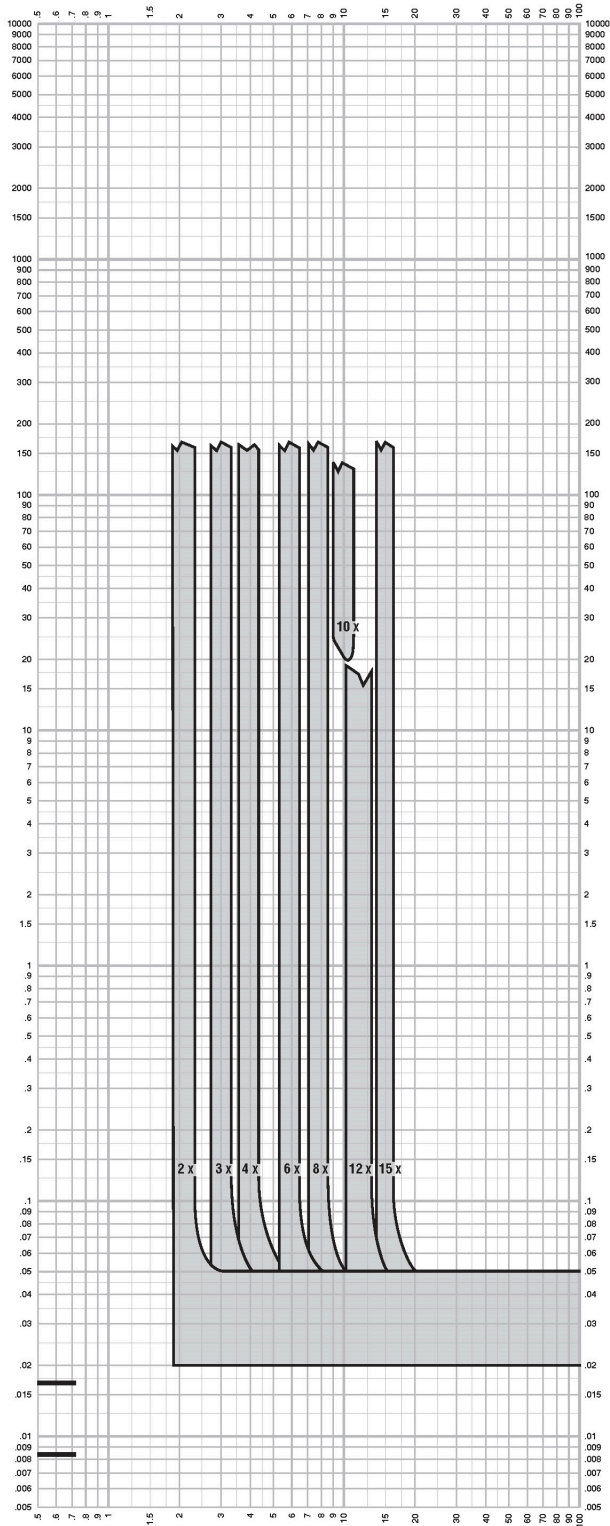

Instantaneous Pickup 2x–15x and OFF

The time-current curve information is to be used for application and coordination purposes only.

Curves apply from -30° to +60°C ambient temperature.

Notes:

1. The end of the curve is determined by the interrupting rating of the circuit breaker.
2. Total clearing times shown include the response times of the trip unit, the circuit breaker opening, and the extinction of the current.
3. The instantaneous region of the trip curve shows maximum total clearing times. Actual clearing times in this region can vary depending on the circuit breaker mechanism design and other factors. The actual clearing time can be considerably faster than indicated.
Contact your local Sales Office for additional information.
4. For a withstand circuit breaker, instantaneous can be turned OFF. \

P, R, NS-Frame Ground Curve and NW-Frame Ground Fault Trip Curve

MULTIPLES OF SENSOR RATING (I_n)

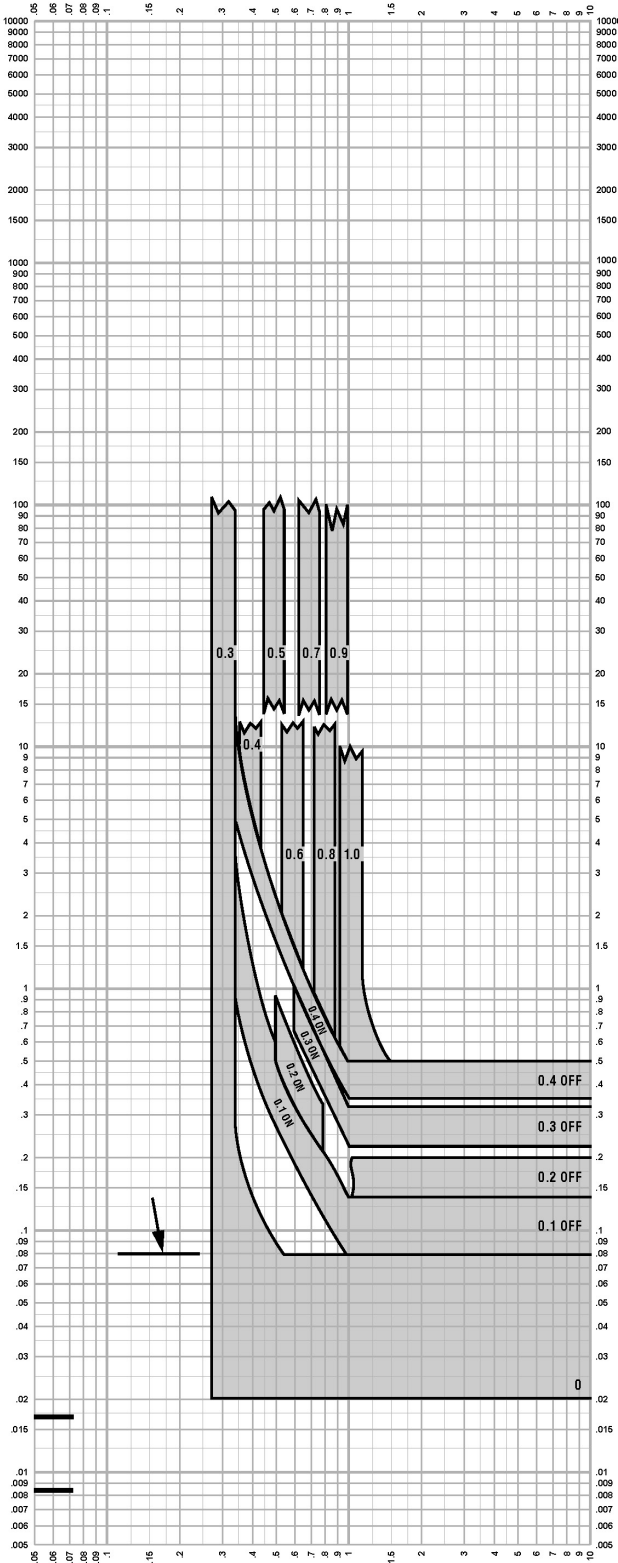

Ground-fault I^2t OFF and ON $I_n \leq 400$ A

The time-current curve information is to be used for application and coordination purposes only.

Curves apply from -30° to $+60^\circ$ C ambient temperature.

Cat[®] Batteries



Cat Batteries — Greater Starting Power — Lower Maintenance — Longer Life

Cat Premium High Output (PHO) batteries are used in all Caterpillar Machines and Engine Gen-Sets. They are designed to meet stringent Caterpillar design specifications, which provide industry leading cold cranking amp (CCA) capability and maximum vibration resistance.

Maintenance Free or low maintenance designs are available in wet and dry configurations.

General Service Line batteries are available in Maintenance Free or low maintenance designs and in wet or dry configurations. Wide selections of BCI group sizes are available for automotive, light truck, bus, industrial, agricultural, marine, recreational and valve regulated (VRLA-AGM & Gel) applications.

Caterpillar. The difference counts.™

Cat Dealers define world – class product support. We offer you the right parts and service solutions, when and where you need them.

The Cat Dealer network of highly trained experts keeps your entire fleet up and running to maximize your equipment investments.

CATERPILLAR[®]

World's Toughest Batteries



Premium High Output – Maximum Vibration Resistance

- Vibration Resistance...five times the Industry Standard
- Exclusive “flat top” BCI group 4D & 8D batteries are Maintenance Free and have the industries highest cold cranking amps (CCA)
- Popular BCI group 31 Maintenance Free batteries with industry leading cold cranking amps...up to 1000 (CCA), for electric power, machine or on-highway truck and bus applications. Deep cycle models available for truck, marine or recreational usage

Specifications for Cat Premium High Output Batteries – Available Worldwide

BCI Group	Part No.	Cold Cranking Amps**	Reserve Capacity Minutes*	Volts	Amp Hr. Capacity @ 20 Hrs.	Construction	Add Water Maintenance Check Hours	BCI Overall Dimensions			Nominal Weight		
								Length In (mm)	Width In (mm)	Height In (mm)	Wet Lb (kg)	Dry Lb (kg)	Nominal Acid to Fill Qt (liter)
8D	153-5720	1500	465	12	210	C	MF	20.47 (520)	10.8 (275)	9.76 (248)	132 (60)	–	–
8D	101-4000	1400	400	12	190	LAC+	1000	20.7 (526.5)	10.96 (278)	9.76 (248)	132 (60)	86 (39)	18.0 (17.0)
4D	153-5710	1400	425	12	200	C	MF	20.47 (520)	8.58 (218)	9.76 (248)	119 (54)	–	–
4D	153-5700	1125	305	12	145	C	MF	20.47 (520)	8.58 (218)	9.76 (248)	101 (46)	–	–
4D	9X-9730	1300	400	12	190	LAC+	1000	20.75 (527)	8.58 (218)	9.76 (248)	119 (54)	81 (37)	14.8 (14.0)
4D	9X-9720	1000	275	12	140	LAC+	1000	20.75 (527)	8.58 (218)	9.76 (248)	101 (46)	59 (27)	15.9 (15.0)
31	175-4390	1000	180	12	90	C/S	MFA	12.9 (328.4)	6.74 (171.2)	9.29 (236)	60 (27)	–	–
31	175-4370	825	190	12	100	C/S**	MFA	12.9 (328.4)	6.74 (171.2)	9.29 (236)	60 (27)	–	–
31	175-4360	710	185	12	100	C/S***	MFA	12.9 (328.4)	6.74 (171.2)	9.29 (236)	60 (27)	–	–
31	250-0480	710	185	12	100	C/SDT***	MF	12.9 (328.4)	6.74 (171.2)	9.29 (236)	60 (27)	–	–
31	115-2422	1000	170	12	90	C SAE	MFA	12.9 (328.4)	6.74 (171.2)	9.46 (240.3)	60 (27)	–	–
31	115-2421	950	170	12	90	C SAE +	MFA	12.9 (328.4)	6.74 (171.2)	9.46 (240.3)	60 (27)	44 (20)	6.6 (6.2)
31	9X-3404	950	165	12	100	C SAE	MF	13 (330.2)	6.77 (172)	9.46 (240.3)	58 (26)	–	–
31	3T-5760	750	165	12	100	C SAE	MF	13 (330.2)	6.77 (172)	9.46 (240.3)	55 (25)	–	–
24	153-5656	650	110	12	52	SC	MF	10.98 (278.9)	6.85 (174)	9.0 (229.1)	39 (18)	–	–
65	230-6368	880	140	12	80	SC	MF	11.9 (303.4)	7.5 (190.8)	7.5 (191.4)	45.5 (21)	–	–
74	153-5660	650	110	12	52	SC*	MF	10.98 (278.9)	7.0 (178.2)	8.15 (206.9)	39 (18)	–	–
58	175-4280	500	70	12	35	SC	MF	9.96 (253.1)	7.2 (182.5)	6.9 (176)	31 (14)	–	–
2	153-5690	765	210	6	90	LAC+	1000	10.24 (260)	6.8 (173)	8.72 (221.6)	37 (17)	22 (10)	4.8 (4.5)

Construction Notes:

LAC = Low Maintenance, Hybrid Construction
 C = Calcium Lead Alloy Grid Design
 MF = Maintenance Free
 MFA = Maintenance Free with Accessible Vent Caps
 S = Stud Terminals
 + = Shipped Dry Only
 * = Side Terminals
 ** = Starting and Deep Cycle Battery
 *** = Deep Cycle and Starting Battery
 " = For 30 seconds at 0° F (-18° C)
 ' = Minimum of 25 amp output at 80° F (27° C)
 SAE = Uses SAE Posts
 SDT = Dual, Top mounted Terminals, Stud and SAE Post, Marine Deep Cycle/Starting Battery
 SC = Silver (Ag) Calcium Alloy Grids for resistance to high underhood temperatures

Rugged Design – Built Tough – Reliable Starting

- Positive and Negative plates are anchored to container bottom and locked at the top of cell element for maximum vibration resistance.
- Heavy-duty forged terminal post bushings provide maximum strength and resistance to acid seepage.
- Hefty full-frame grids, no sharp edges, optimum acid/paste combination provides better charge acceptance after deep discharge.
- Manifold vented cover with built-in Flame Arrestor...a safety feature that directs corrosive gases away from the battery and hold-downs.
- Thick, robust container resists rugged treatment typical of heavy-duty commercial use. Embossed part number & descriptors for easy serviceability.

Cat Batteries

Heavy-duty Forged Terminal Post Bushings

Built-in Flame Arrestor

Robust Reinforced Case

Vibration Resistant Plates & Elements

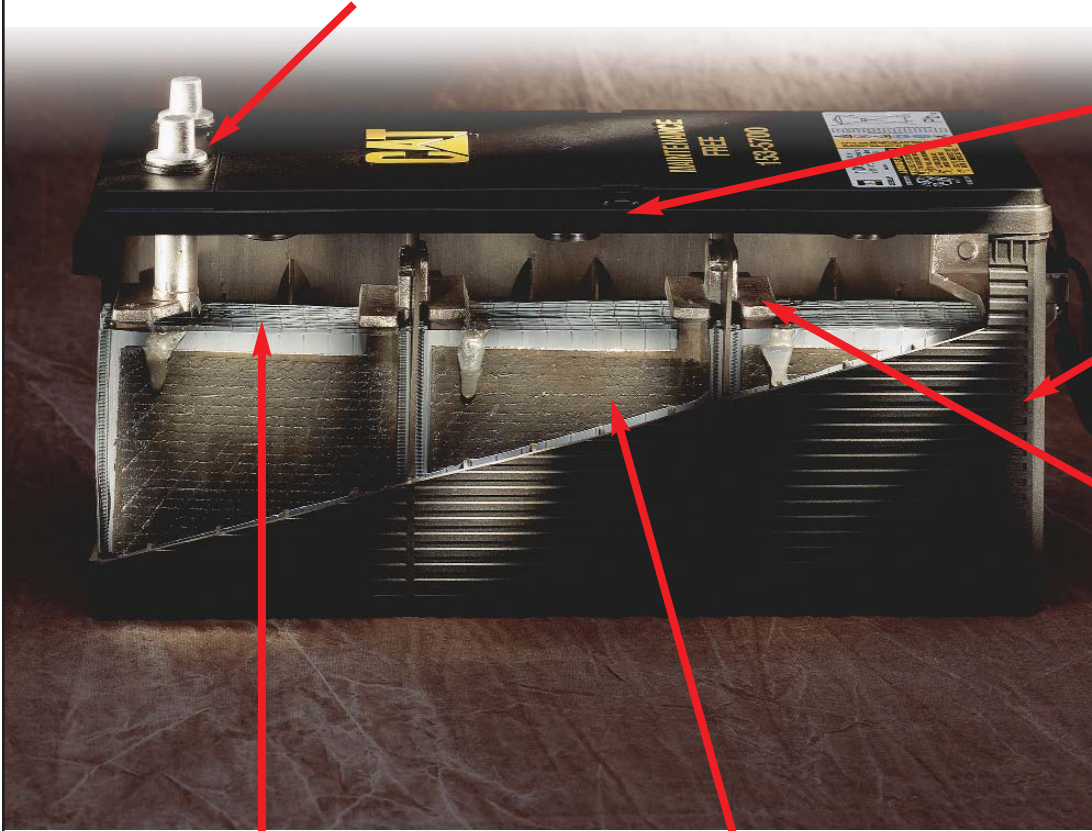

Heavy-duty Grids

Rugged Separators

Robust Components = Long Life + Reliable Starts

- Heavy-duty forged terminal post bushings provide maximum strength and resistance to acid seepage that causes corrosion and black posts. Thicker internal terminal posts provide lower electrical resistance and higher cold cranking amp output.
- Rugged microporous polyethylene envelope separators protect against “shorts” and vibration damage. Deep Cycle batteries utilize double insulated Glass mat separators for longer cycling life.
- Maintenance Free batteries utilize calcium lead alloy on both positive and negative plates that reduces gassing and water consumption. Automotive batteries have Silver (Ag) Calcium Alloy Grids for resistance to high underhood temperatures.
- Heavy-duty, full frame battery grids with no sharp edges. An optimum acid/paste combination provides better charge acceptance after a deep discharge.
- Positive and Negative plates are anchored to the container bottom and the cell element is locked at the top for maximum vibration resistance. Straps are thicker, heavier and cast (not welded) into the plates.
- Manifold vented cover with built-in Flame Arrestor...a safety feature that directs corrosive gases away from the battery and hold-downs.
- Robust reinforced case provides extra strength in all temperature extremes. Brickwork design on sides reduces chance of punctures and case flexing. Embossed part number and descriptors for easy serviceability.

CAT, CATERPILLAR, their respective logos and “Caterpillar Yellow,” as well as corporate and product identity used herein, are trademarks of Caterpillar and may not be used without permission.

For more information, see us today or visit our web site at www.cat.com

Caterpillar. The difference counts.™

CATERPILLAR®



Image shown might not reflect actual configuration

SPECIFICATION

AC SUPPLY

VOLTAGE RANGE 90 V to 305 V (L-N)

FREQUENCY RANGE

48 Hz to 64 Hz (L-N)

DC OUTPUT RATING

10 A DC at 24 V DC

RIPPLE AND NOISE

<1%

EFFICIENCY

>86%

REGULATION LINE

<0.5%

LOAD

2%

TEMPERATURE SENSOR INPUT

PT1000

PROTECTIONS

Short Circuit
DC Over Voltage
DC Over Current
Reverse Polarity
Over Temperature
AC Under & Over Voltage

CHARGE FAILURE RELAY

3 A at 30 V DC volt free relay

DIMENSIONS OVERALL

70 mm x200 mm x 130 mm
2.7" x 7.9" x 5.1"

WEIGHT

0.75 kg

OPERATING TEMPERATURE RANGE

-30 °C to +80 °C
-22 °F to +176 °F

STORAGE TEMPERATURE RANGE

-40 °C to +70 °C
-22 °F to +158 °F

BATTERY CHARGER

The intelligent battery charger has been developed with safety, usability, optimised battery performance and maximum battery lifetimes in mind.

A comprehensive range of input and output protections ensures a continued safe charging environment also enabling the use of the charger as a power supply.

FEATURES

- Intelligent two, three and four stage charging profiles
- Configurable to suit most battery types (12V/24V)
- Adjustable current limit
- Can be used as a battery charger, power supply or both at the same time
- Automatic or Manual boost and storage charge functions to help maintain battery condition
- Digital Microprocessor Technology
- Temperature compensation for battery charging
- Low Output Ripple and superb line regulation
- Three LED Indicators
- AC input Under voltage
- AC input Over voltage
- Battery charger output Over voltage
- Battery charger output Over current
- Optional battery temperature compensation with over temperature protection
- Output short circuit and Inversion polarity with auto recovery
- Configurable charge termination
- UL1236 /UL1564 Compliant

Automatic Boost Mode

- Boosts and equalises cell charge improving battery performance and life

Power Save Mode

- Once the battery is fully charged the chargers switch to Eco-Power to save energy

Communication

- Can be integrated into external systems through MODBUS RTU using RS485
- Fully configurable via PC Software

BENEFITS

- Fully flexible to maximise the life of the battery
- Suitable for a wide range of battery types
- Switched mode design
- Minimum 86% efficiency throughout full operating range
- No external intervention for boost mode
- Multiple chargers can be linked together to provide larger current output
- Can be permanently connected to battery and mains (utility) supply. No need to disconnect through high load conditions.

LEHE2022-02 (10-20)

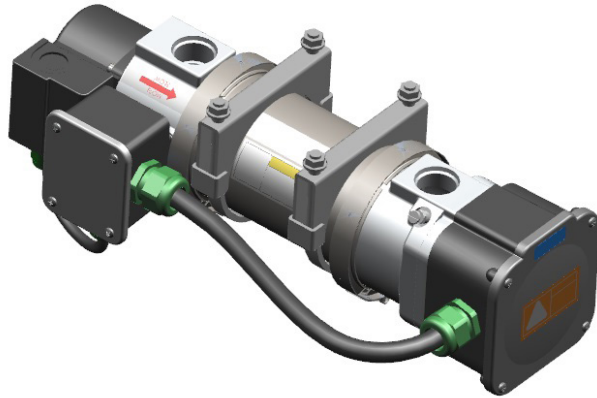

Features

Factory Installed

- Complete with Hoses, Thermostat (Control and Hi-Limit) and Pump
- Base Frame mounting minimizes Engine induced vibration
- Temperature Controlled Pump operation
- Supplied with UL, C (UL) US and CE recognized components
- Control Thermostat is Factory preset to 49°C (120°F)

Heater Design Description

- Jacket Water Heater Package is designed to efficiently preheat the engine by circulating the heated coolant onto engine
- This design results in following benefits
- Increase life of Heater Hoses, Engine Seals and Heating Elements
- Improves Heat Transfer efficiency from Elements to Engine Coolant
- Uniform Engine temperature distribution
- Application of Thermostat with a reduced thermal differential
- Lower Customer utility costs and increased Heater reliability
- Heater's Control Thermostat set point is preset

Jacket Water Heater with Pump Diesel Gensets: C27, C32

Caterpillar offers a factory installed Jacket Water Heater for improved Engine Cold-Starting capability

This Jacket Water Heater is a Thermostatically controlled Heater with an integrated pump, built in bleed screw and High Limit Thermostat that can be manually reset

Forced circulation of the coolant delivers uniform heating throughout the entire engine, reduces wear from Cold spots and offers significant reduction of Electrical consumption

Heater Operation

A 34 L/pm (9 GPM) Pump is located at the Heater Inlet to push the coolant through the Heater
A Control Thermostat is located inside a Plastic Enclosure near the Inlet of Heater and responds to the temperature of coolant entering the tank
A High Limit Thermostat is located inside a Plastic Element Enclosure near the Outlet of Heater opens and cuts off supply to Heating Element, if tank attains 96°C (205°F). This Thermostat can be manual reset to close position.

Temperature Controlled Pump Operation – Pump runs only with Heating Elements.

Air release valve (Bleed Screw) provided to allow vent air from Heater, prior to energizing the Heater.

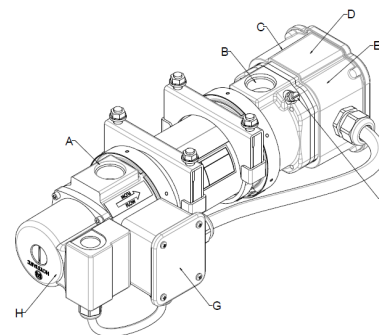

- | | |
|--|---|
| A. Suction Port (SAE Dash 16) | E. High-limit Thermostat with manual reset (in Element assembly) |
| B. Discharge Port (SAE Dash 16) | F. Air Release Valve |
| C. Power in Wiring Entrance | G. Control Thermostat (in enclosure) |
| D. Element Assembly | H. Pump/Motor |

Specifications

	Voltage	
	240	220
Heater Power	6kW	6kW
Frequency	60	50
Phase	Single	Single
Amps	25A	26A
Flow Rate	34 L/pm (9 GPM)	
Pump Rating	230 VAC 97W	230 VAC 70W
Control Thermostat (Set Point)	38°C – 49°C (100°F – 120°F)	
High Limit Thermostat (Set Point)	96°C (205°F), Manual Reset	
Length	466 mm (18.3")	
Width	216 mm (8.5")	
Height	183 mm (7.2")	
Weight	6.5 Kg	

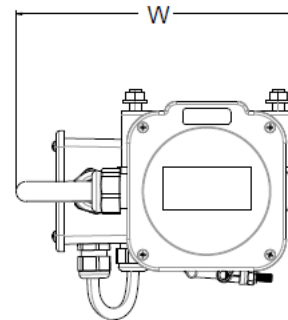
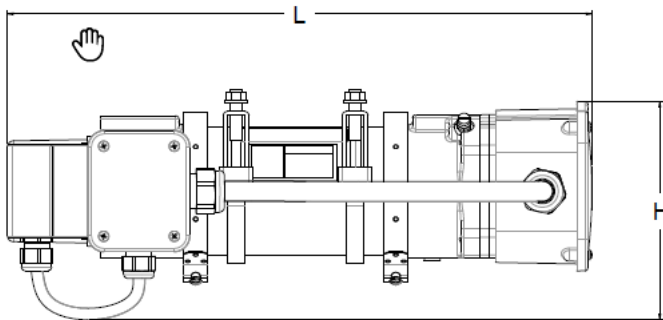

No contractor installation required.

Input supply is sourced from the factory installed auxiliary panelboard in the generator enclosure.

208VAC customer-supplied shore power is distributed to the Jacket Water Heater internal to the generator cabinet.

Separate 208VAC circuit not required.
See 'Project Specific Notes & Technical Information' for details.

Wiring Diagram

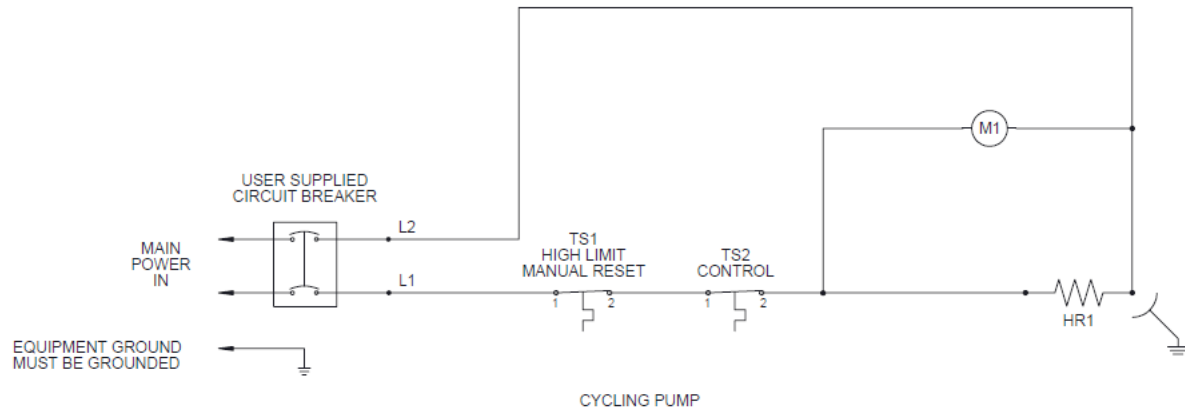

Materials and specifications are subject to change without notice. The International System of Units (SI) is used in this publication.
© 2021 Caterpillar. All Rights Reserved. CAT, CATERPILLAR, LET'S DO THE WORK, their respective logos, "Caterpillar Corporate Yellow", the "Power Edge" and Cat "Modern Hex" trade dress as well as corporate and product identity used herein, are trademarks of Caterpillar and may not be used without permission

100 Amp Load Center



Image shown may not reflect actual package.

100 Amp Load Center

Specifications	
Number of spaces	8
System voltage	120 / 240 VAC
Number of tandem circuit breakers	8
Phase	1 Ph
NEMA degree of protection	NEMA 1 indoor
Electrical connection	Lugs
Wiring configuration	3-wire
Material	Tin plated aluminum busbar
Enclosure material	Welded sheet steel
Cover finish	Gray baked enamel
Product certifications	CULus
Wire Size	AWG 4...AWG 1 (Aluminum / Copper)
Rated Current	100A
Max Short Circuit Rating	10 kA
Ground Connection	Grounding bar (factory installed)
Cover Type	Surface cover with door

Dimensions and Load Specifications	
Height / Width / Depth	319 mm / 226 mm / 97 mm
GFCI	20A (120V)
Battery Charger	2.3A (240V)
Jacket Water Heater	25.4A (240V)
Alternator Heater	1.1A (240V)
Total Load	48.8A Max

L1 Load Specifications	
Battery Charger	2.3A (240V)
GFCI	20A (120V)
Jacket Water Heater	25.4A (240V)
Alternator Heater	1.1A (240V)
Total Load	48.8A Max

L2 Load Specifications	
Battery Charger	2.3A (240V)
Jacket Water Heater	25.4A (240V)
Alternator Heater	1.1A (240V)
Total Load	28.8A Max

www.cat.com/electricpower

©2020 Caterpillar
All rights reserved.

Information contained in this publication may be considered confidential. Discretion is recommended when distributing. Materials and specifications are subject to change without notice.

CAT, CATERPILLAR, LET'S DO THE WORK, their respective logos, "Caterpillar Corporate Yellow," the "Power Edge" and Cat "Modern Hex" trade dress as well as corporate and product identity used herein, are trademarks of Caterpillar and may not be used without permission.



Image shown may not reflect actual configuration.

C27 – C32 GC Enclosures

800 – 1250 ekW NA

Sound Attenuated and Weather Protective Enclosures for C27 and C32 GC Generator Sets

These sound attenuated and weather protective, factory installed enclosures are designed for safety and aesthetic value. Rugged construction provides weather protection and the ability to withstand exposure to the elements.

FEATURES

Robust/Highly Corrosion-Resistant Construction

- Environmentally friendly, polyester powder-baked paint in Caterpillar White
- Zinc plated and stainless steel fasteners
- 14-Gauge steel construction
- Flat roof with protection for water ingress from rain
- Critical grade internally mounted muffler/exhaust system
- Soft mounted isolators
- 75 dbA @ 7m (Target value) for Sound attenuated enclosures

Excellent Access

- Control panel mounted on RH side with an optional auxiliary box on the LH side of the package
- Large cable entry area for the ease of installation
- Left-hand or Right-hand bottom entry access to power cable bus or circuit breaker
- Multiple doors on both sides allow easy access to service points
- Hinged doors allow 180° opening rotation
- Lube oil and coolant drains piped to exterior of enclosure and terminated drain valves
- Radiator fill cover

Options

- Weather protective enclosure available with same footprint
- Interior DC lighting systems
- Caterpillar White paint (Default)
- 2100 (Factory installed), 3000 and 4200 (shipped loose) gallon fuel tanks
- 100 mph wind loading

Security and Safety

- Lockable access doors with standard key use
- Cooling fan and battery charging alternator fully guarded
- Oil fill and battery can only be reached via lockable access
- External fuel connections
- Externally mounted emergency stop buttons
- Designed for spreader bar lifting to ensure safety

Certifications

- UL 2200 listed & cUL
- Seismic certification per applicable building codes: IBC 2021
- Tested and analysed in accordance with: ASCE 7-98, ASCE 7-02, ASCE 7-05, ICC-ES AC-156

Refer to Bill of Materials for exact weight and dimensions.

Enclosure Weights and Dimensions

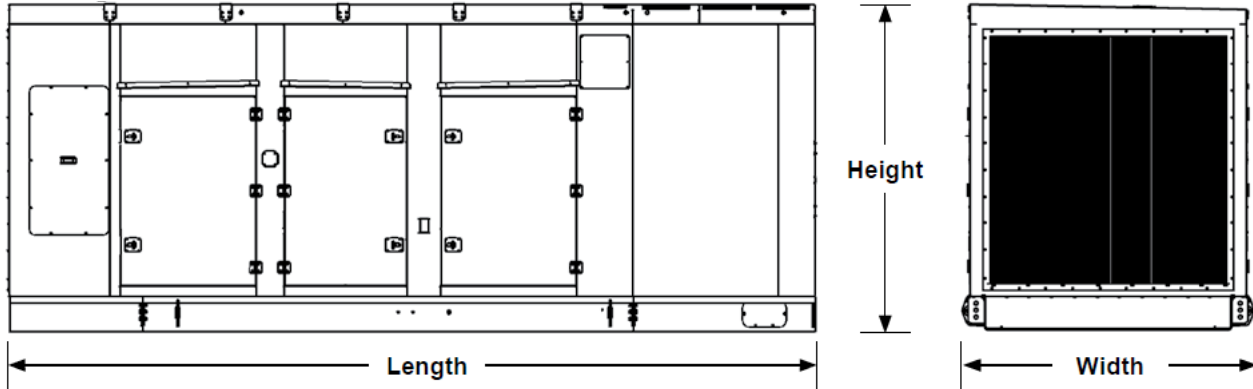

Sound Attenuated Enclosure Base Options*	Weight kgs (lbs)	Length mm (in)	Width mm (in)	Height mm (in)
With lifting base	2672 (5891)	6610 (260)	2342 (92.2)	2350 (92.5)
With 2100 gal integral tank base	4891 (10783)	7620 (300)	2350 (92.5)	3265 (128.5)
With 3000 gal tank with lifting base	5638 (12429)	7646 (301)	2471 (97)	3565 (140)
With 4200 gal tank with lifting base	6563 (14468)	7646 (301)	2471 (97)	3870 (152)

Weather Protective Enclosure Base Options*	Weight kgs (lbs)	Length mm (in)	Width mm (in)	Height mm (in)
With lifting base	2452 (5405)	6610 (260)	2342 (92.2)	2350 (92.5)
With 2100 gal integral tank base	4671 (10298)	7620 (300)	2350 (92.5)	3265 (128.5)
With 3000 gal tank with lifting base	5418 (11944)	7646 (301)	2471 (97)	3565 (140)
With 4200 gal tank with lifting base	6343 (13984)	7646 (301)	2471 (97)	3870 (152)

Note: For reference only – do not use for installation design. Please contact your dealer for exact weights and dimensions.
 *Weight does not include package generator set weight.

Generator Set Weights

Generator Set Weights**	Weight kgs (lbs)
C27 Open generator set	5813 (12815)
C32 Open generator set	6798 (14987)

**Dry Weight of heaviest configuration and without base rail weight (Does not include exhaust system weights).

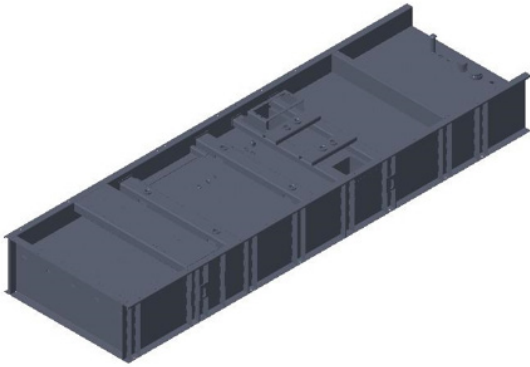

Picture shown may not reflect actual configuration

Features

- UL 142 (US) and ULC S601 (Canada) Listed
- Facilitates compliance to NFPA 30, 70 and 110
- CSA C282-09 and B139-04 installation compliant
- Dual wall, secondary containment (minimum of 110% of primary tank capacity)
- Tank design provides capacity for thermal expansion of fuel
- Direct reading fuel level gauge
- Fuel supply dip tube is positioned so as not to pick up fuel sediment
- Fuel return and supply dip tubes are separated by an internal baffle to prevent recirculation of heated return fuel
- Fuel fill – 43 mm (1.7 in), lockable flip top cap
- Primary tank level detection switch in containment basin
- Primary and secondary tanks are leak tested at 20.7 kPa (3 psi) minimum
- Interior tank surfaces coated with a solvent-based thin-film rust preventative
- Heavy gauge steel gussets suitable for lifting package (2100 gal only)
- Gloss black polyester alkyd acrylic enamel exterior paint over epoxy based primer
- Primary tanks are equipped with customer Lockable 2" raised fuel fill with optional seven gallon spill containment
- Leak detection switch
- Port for access to containment tank
- Removable engine supply and return dip tubes
- Fittings for opt fuel levels or auxiliary fuel pump
- Excellent stub-up access beneath circuit breaker (within fuel tank)
- Emergency vents on primary and secondary tanks are sized in accordance with NFPA 30, external to enclosure.
- Optional installed fuel level indication at the generator set control panel.
- Optional seismic certification per applicable building codes: IBC 2021
- Tested and analyzed in accordance with: ASCE 7-98, ASCE 7-02, ASCE 7-05, ICC- ES AC-156
- Anchoring details are site specific, and are dependent on many factors such as generator set size, weight, and concrete strength. IBC Certification requires that the anchoring system used is reviewed and approved by a Professional Engineer.

Fuel Tank Bases for D800 GC - D1250 GC

Dual Wall fuel tank bases offer an integrated fuel solution for your Cat GC diesel generator set.



Standby Rating		Engine	Strategy	Run Time @ 100% Load (Hrs)		
ekW	kVA			2100 gal	3000 gal*	4200 gal*
1250	1562	C32	ESE (Tier 2)	24.3	34.8	48.7
1000	1250	C32	ESE (Tier 2)	29.4	42.0	58.7
800	1000	C27	ESE (Tier 2)	37.8	54.0	75.5

*Requires enclosure lifting base, and fuel tank is shipped loose. Not available with IBC certification.

LET'S DO THE WORK.™

www.cat.com/electricpower
 ©2022 Caterpillar All rights reserved.

Materials and specifications are subject to change without notice. The International System of Units (SI) is used in this publication. CAT, CATERPILLAR, LET'S DO THE WORK, their respective logos, "Caterpillar Corporate Yellow" the "Power Edge" and Cat "Modern Hex" trade dress as well as corporate and product identity used herein, are trademarks of Caterpillar and may not be used without permission.

TAB 4: REVISION HISTORY AND APPROVALS PAGE

- 4.1 Caterpillar Warranty Card
- 4.2 Revision History and Approval

Effective with sales to the first user on or after August 1, 2014

CATERPILLAR LIMITED WARRANTY

Industrial, Petroleum, Locomotive, and Agriculture Engine Products and Electric Power Generation Products

Worldwide

Caterpillar Inc. or any of its subsidiaries ("Caterpillar") warrants new and remanufactured engines and electric power generation products sold by it (including any products of other manufacturers packaged and sold by Caterpillar), to be free from defects in material and workmanship.

This warranty does not apply engines sold for use in on-highway vehicle or marine applications; engines in machines manufactured by or for Caterpillar; C175, 3500 and 3600 series engines used in locomotive applications; 3000 Family engines, C0.5 through C4.4 and ACERT™ (C6.6, C7, C7.1, C9, C9.3, C11, C13, C15, C18, C27, and C32) engines used in industrial, mobile agriculture and locomotive applications; or Cat® batteries. These products are covered by other Caterpillar warranties.

This warranty is subject to the following:

Warranty Period

- For industrial engines, engines in a petroleum applications or Petroleum Power Systems (excluding petroleum fire pump application), or engines in a Locomotive application, or Uninterruptible Power Supply (UPS) systems, the warranty period is 12 months after date of delivery to the first user.
- For engines used in petroleum fire pump and mobile agriculture applications the warranty period is 24 months after date of delivery to the first user.
- For controls only (EPIC), configurable and custom switchgear products, and automatic transfer switch products, the warranty period is 24 months after date of delivery to the first user.
- For new CG132, CG170 and CG260 series power generation products the warranty period is 24 months/16,000 hours, whichever comes first, after date of delivery to first user.
- For electric power generation products other than CG132, CG170 and CG260 series in prime or continuous applications the warranty period is 12 months. **For standby applications the warranty period is 24 months/1000 hours. For emergency standby applications the warranty period is 24 months/400 hours. All terms begin after date of delivery to the first user.**
- For all other applications the warranty period is 12 months after date of delivery to the first user.

Caterpillar Responsibilities

If a defect in material or workmanship is found during the warranty period, Caterpillar will, during normal working hours and at a place of business of a Cat dealer or other source approved by Caterpillar:

- Provide (at Caterpillar's choice) new, Remanufactured, or Caterpillar approved repaired parts or assembled components needed to correct the defect.
- **Note:** New, remanufactured, or Caterpillar approved repaired parts or assembled components provided under the terms of this warranty are warranted for the remainder of the warranty period applicable to the product in which installed as if such parts were original components of that product. Items replaced under this warranty become the property of Caterpillar.
- Replace lubricating oil, filters, coolant, and other service items made unusable by the defect.
- Provide reasonable and customary labor needed to correct the defect, including labor to disconnect the product from and reconnect the product to its attached equipment, mounting, and support systems, if required.

For new 3114, 3116, and 3126 engines and electric power generation products (including any new products of other manufacturers packaged and sold by Caterpillar):

- Provide travel labor, up to four hours round trip, if in the opinion of Caterpillar, the product cannot reasonably be transported to a place of business of a Cat dealer or other source approved by Caterpillar (travel labor in excess of four hours round trip, and any meals, mileage, lodging, etc. is the user's responsibility).

For all other products:

- Provide reasonable travel expenses for authorized mechanics, including meals, mileage, and lodging, when Caterpillar chooses to make the repair on-site.

User Responsibilities

The user is responsible for:

- Providing proof of the delivery date to the first user.
- Labor costs, except as stated under "Caterpillar Responsibilities," including costs beyond those required to disconnect the product from and reconnect the product to its attached equipment, mounting, and support systems.

- Travel or transporting costs, except as stated under "Caterpillar Responsibilities."
- Premium or overtime labor costs.
- Parts shipping charges in excess of those that are usual and customary.
- Local taxes, if applicable.
- Costs to investigate complaints, unless the problem is caused by a defect in Caterpillar material or workmanship.
- Giving timely notice of a warrantable failure and promptly making the product available for repair.
- Performance of the required maintenance (including use of proper fuel, oil, lubricants, and coolant) and items replaced due to normal wear and tear.
- Allowing Caterpillar access to all electronically stored data.

Limitations

Caterpillar is not responsible for:

- Failures resulting from any use or installation that Caterpillar judges improper.
- Failures resulting from attachments, accessory items, and parts not sold or approved by Caterpillar.
- Failures resulting from abuse, neglect, and/or improper repair.
- Failures resulting from user's delay in making the product available after being notified of a potential product problem.
- Failures resulting from unauthorized repairs or adjustments, and unauthorized fuel setting changes.
- Damage to parts, fixtures, housings, attachments, and accessory items that are not part of the engine, Cat Selective Catalytic Reduction System or electric power generation product (including any products of other manufacturers packaged and sold by Caterpillar).
- Repair of components sold by Caterpillar that is warranted directly to the user by their respective manufacturer. Depending on type of application, certain exclusions may apply. Consult your Cat dealer for more information.

(Continued on reverse side...)

This warranty covers every major component of the products. Claims under this warranty should be submitted to a place of business of a Cat dealer or other source approved by Caterpillar. For further information concerning either the location to submit claims or Caterpillar as the issuer of this warranty, write Caterpillar Inc., 100 N. E. Adams St., Peoria, IL USA 61629.

Caterpillar's obligations under this Limited Warranty are subject to, and shall not apply in contravention of, the laws, rules, regulations, directives, ordinances, orders, or statutes of the United States, or of any other applicable jurisdiction, without recourse or liability with respect to Caterpillar.

A) For products operating outside of Australia, Fiji, Nauru, New Caledonia, New Zealand, Papua New Guinea, the Solomon Islands and Tahiti, the following is applicable:

NEITHER THE FOREGOING EXPRESS WARRANTY NOR ANY OTHER WARRANTY BY CATERPILLAR, EXPRESS OR IMPLIED, IS APPLICABLE TO ANY ITEM CATERPILLAR SELLS THAT IS WARRANTED DIRECTLY TO THE USER BY ITS MANUFACTURER.

THIS WARRANTY IS EXPRESSLY IN LIEU OF ANY OTHER WARRANTIES, EXPRESS OR IMPLIED, INCLUDING ANY WARRANTY OF MERCHANTABILITY OR FITNESS FOR A PARTICULAR PURPOSE, EXCEPT CATERPILLAR EMISSION-RELATED COMPONENTS WARRANTIES FOR NEW ENGINES, WHERE APPLICABLE. REMEDIES UNDER THIS WARRANTY ARE LIMITED TO THE PROVISION OF MATERIAL AND SERVICES, AS SPECIFIED HEREIN.

CATERPILLAR IS NOT RESPONSIBLE FOR INCIDENTAL OR CONSEQUENTIAL DAMAGES.

CATERPILLAR EXCLUDES ALL LIABILITY FOR OR ARISING FROM ANY NEGLIGENCE ON ITS PART OR ON THE PART OF ANY OF ITS EMPLOYEES, AGENTS OR REPRESENTATIVES IN RESPECT OF THE MANUFACTURE OR SUPPLY OF GOODS OR THE PROVISION OF SERVICES RELATING TO THE GOODS.

IF OTHERWISE APPLICABLE, THE VIENNA CONVENTION ON CONTRACTS FOR THE INTERNATIONAL SALE OF GOODS IS EXCLUDED IN ITS ENTIRETY.

For personal or family use engines or electric power generation products, operating in the USA, its territories and possessions, some states do not allow limitations on how long an implied warranty may last nor allow the exclusion or limitation of incidental or consequential damages. Therefore, the previously expressed exclusion may not apply to you. This warranty gives you specific legal rights and you may also have other rights, which vary by jurisdiction. To find the location of the nearest Cat dealer or other authorized repair facility, call (800) 447-4986. If you have questions concerning this warranty or its applications, call or write:

In USA and Canada: Caterpillar Inc., Engine Division, P. O. Box 610, Mossville, IL 61552-0610, Attention: Customer Service Manager, Telephone (800) 447-4986. Outside the USA and Canada: Contact your Cat dealer.

B) For products operating in Australia, Fiji, Nauru, New Caledonia, New Zealand, Papua New Guinea, the Solomon Islands and Tahiti, the following is applicable:

THIS WARRANTY IS IN ADDITION TO WARRANTIES AND CONDITIONS IMPLIED BY STATUTE AND OTHER STATUTORY RIGHTS AND OBLIGATIONS THAT BY ANY APPLICABLE LAW CANNOT BE EXCLUDED, RESTRICTED OR MODIFIED ("MANDATORY RIGHTS"). ALL OTHER WARRANTIES OR CONDITIONS, EXPRESS OR IMPLIED (BY STATUTE OR OTHERWISE), ARE EXCLUDED. WITHOUT LIMITING THE FOREGOING PROVISIONS OF THIS PARAGRAPH, WHERE A PRODUCT IS SUPPLIED FOR BUSINESS PURPOSES, THE CONSUMER GUARANTEES UNDER THE CONSUMER GUARANTEES ACT 1993 (NZ) WILL NOT APPLY.

NEITHER THIS WARRANTY NOR ANY OTHER CONDITION OR WARRANTY BY CATERPILLAR, EXPRESS OR IMPLIED (SUBJECT ONLY TO THE MANDATORY RIGHTS), IS APPLICABLE TO ANY ITEM CATERPILLAR SELLS THAT IS WARRANTED DIRECTLY TO THE USER BY ITS MANUFACTURER.

IF THE MANDATORY RIGHTS MAKE CATERPILLAR LIABLE IN CONNECTION WITH SERVICES OR GOODS, THEN TO THE EXTENT PERMITTED UNDER THE MANDATORY RIGHTS, THAT LIABILITY SHALL BE LIMITED AT CATERPILLAR'S OPTION TO (a) IN THE CASE OF SERVICES, THE SUPPLY OF THE SERVICES AGAIN OR THE PAYMENT OF THE COST OF HAVING THE SERVICES SUPPLIED AGAIN AND (b) IN THE CASE OF GOODS, THE REPAIR OR REPLACEMENT OF THE GOODS, THE SUPPLY OF EQUIVALENT GOODS, THE PAYMENT OF THE COST OF SUCH REPAIR OR REPLACEMENT OR THE ACQUISITION OF EQUIVALENT GOODS.

CATERPILLAR EXCLUDES ALL LIABILITY FOR OR ARISING FROM ANY NEGLIGENCE ON ITS PART OR ON THE PART OF ANY OF ITS EMPLOYEES, AGENTS OR REPRESENTATIVES IN RESPECT OF THE MANUFACTURE OR SUPPLY OF GOODS OR THE PROVISION OF SERVICES RELATING TO THE GOODS.

CATERPILLAR IS NOT LIABLE FOR INCIDENTAL OR CONSEQUENTIAL DAMAGES UNLESS IMPOSED UNDER MANDATORY RIGHTS.

IF OTHERWISE APPLICABLE, THE VIENNA CONVENTION ON CONTRACTS FOR THE INTERNATIONAL SALE OF GOODS IS EXCLUDED IN ITS ENTIRETY.

C) For products supplied in Australia:

IF THE PRODUCTS TO WHICH THIS WARRANTY APPLIES ARE:

- I. PRODUCTS OF A KIND ORDINARILY ACQUIRED FOR PERSONAL, DOMESTIC OR HOUSEHOLD USE OR CONSUMPTION; OR
- II. PRODUCTS THAT COST AUD 40,000 OR LESS,

WHERE THOSE PRODUCTS WERE NOT ACQUIRED FOR THE PURPOSE OF RE-SUPPLY OR FOR THE PURPOSE OF USING THEM UP OR TRANSFORMING THEM IN THE COURSE OF PRODUCTION OR MANUFACTURE OR IN THE COURSE OF REPAIRING OTHER GOODS OR FIXTURES, THEN THIS SECTION C APPLIES.

THE FOLLOWING MANDATORY TEXT IS INCLUDED PURSUANT TO THE AUSTRALIAN CONSUMER LAW AND INCLUDES REFERENCES TO RIGHTS THE USER MAY HAVE AGAINST THE DIRECT SUPPLIER OF THE PRODUCTS: OUR GOODS COME WITH GUARANTEES THAT CANNOT BE EXCLUDED UNDER THE AUSTRALIAN CONSUMER LAW. YOU ARE ENTITLED TO A REPLACEMENT OR REFUND FOR A MAJOR FAILURE AND COMPENSATION FOR ANY OTHER REASONABLY FORESEEABLE LOSS OR DAMAGE. YOU ARE ALSO ENTITLED TO HAVE THE GOODS REPAIRED OR REPLACED IF THE GOODS FAIL TO BE OF ACCEPTABLE QUALITY AND THE FAILURE DOES NOT AMOUNT TO A MAJOR FAILURE. THE INCLUSION OF THIS TEXT DOES NOT CONSTITUTE ANY REPRESENTATION OR ACCEPTANCE BY CATERPILLAR OF LIABILITY TO THE USER OR ANY OTHER PERSON IN ADDITION TO THAT WHICH CATERPILLAR MAY HAVE UNDER THE AUSTRALIAN CONSUMER LAW.

TO THE EXTENT THE PRODUCTS FALL WITHIN THIS SECTION C BUT ARE NOT OF A KIND ORDINARILY ACQUIRED FOR PERSONAL, DOMESTIC OR HOUSEHOLD USE OR CONSUMPTION, CATERPILLAR LIMITS ITS LIABILITY TO THE EXTENT IT IS PERMITTED TO DO SO UNDER THE AUSTRALIAN CONSUMER LAW TO, AT ITS OPTION, THE REPAIR OR REPLACEMENT OF THE PRODUCTS, THE SUPPLY OF EQUIVALENT PRODUCTS, OR THE PAYMENT OF THE COST OF SUCH REPAIR OR REPLACEMENT OR THE ACQUISITION OF EQUIVALENT PRODUCTS.

THE WARRANTY SET OUT IN THIS DOCUMENT IS GIVEN BY CATERPILLAR INC. OR ANY OF ITS SUBSIDIARIES, 100 N. E. ADAMS ST, PEORIA, IL USA 61629, TELEPHONE 1 309 675 1000, THE USER IS RESPONSIBLE FOR ALL COSTS ASSOCIATED WITH MAKING A CLAIM UNDER THE WARRANTY SET OUT IN THIS DOCUMENT, EXCEPT AS EXPRESSLY STATED OTHERWISE IN THIS DOCUMENT, AND THE USER IS REFERRED TO THE BALANCE OF THE DOCUMENT TERMS CONCERNING CLAIM PROCEDURES, CATERPILLAR RESPONSIBILITIES AND USER RESPONSIBILITIES.

TO THE EXTENT PERMISSIBLE BY LAW, THE TERMS SET OUT IN THE REMAINDER OF THIS WARRANTY DOCUMENT (INCLUDING SECTION B) CONTINUE TO APPLY TO PRODUCTS TO WHICH THIS SECTION C APPLIES.

©2014 Caterpillar All Rights Reserved.

CAT, CATERPILLAR, their respective logos, "Caterpillar Yellow" the "Power Edge" trade dress as well as corporate and product identity used herein, are trademarks of Caterpillar and may not be used without permission.

Revision History

<u>Revision No.</u>	<u>Date</u>	<u>Description</u>	<u>Submitted By</u>
0	04/11/24	Initial Submission	PP

Signature: _____

Name: _____

Revision No.: _____

Date: _____

