

SECTION 1

Project Information



Bill of Material

Feature Code	Description	Qty
C200N6B	C200N6B, 200kW, 60Hz, Standby, Natural Gas Genset	1
C200N6B	C200N6B, 200kW, 60Hz, Standby, Natural Gas Genset	
Install-US-Stat	U.S. EPA, Stationary Emergency Application	
A331-2	Duty Rating - Standby Power (ESP)	
L155-2	Emissions Certification - SI, EPA, Emergency, Stationary, 40CFR60	
L090-2	Listing - UL 2200	
L193-2	NFPA 110 Type 10 Level 1 Capable	
R002-2	Voltage - 277/480, 3 Phase, Wye, 4 Wire	
BB95-2	Alternator - 60Hz, 12L, 480/277V, 105C, 40C Ambient, Increased Motor Starting (IMS)	
B184-2	Exciter/Regulator - Permanent Magnet Generator, 3 Phase Sensor	
F217-2	Aluminum Sound Attenuated Level 2 Enclosure, with Exhaust System	
P176-2	Enclosure Color - Green, Aluminum	
F252-2	Enclosure - Wind Load 180 MPH, ASCE7-10	
F179-2	Skidbase - Housing Ready	
H609-2	Control Mounting - Left Facing	
H703-2	PowerCommand 2.3 Controller	
H012-2	Gauge - Oil Pressure	
K796-2	Stop Switch - Emergency	
H536-2	Control Display Language - English	
KV03-2	Load Connection - Single	
KX30-2	Circuit Breaker, Location A, 125A - 400A, 3P, LSI, 600 Volts AC, 100%, UL	
KB72-2	Circuit Breaker or Entrance Box - Bottom Entry,Right Side	
A366-2	Engine Governor - Electronic, Isochronous	
C002-2	Single Gas Fuel - NG	
A422-2	Engine Starter - 12 Volt DC Motor	
D041-2	Engine Air Cleaner - Normal Duty	

A333-2	Battery Charging Alternator	
BB89-2	Battery Charger - 6 Amp, Regulated	
E125-2	Engine Cooling - Radiator, High Ambient Air Temperature, Ship Fitted	
H527-2	Warning - Low Coolant Level	
E089-2	Extension - Coolant Drain	
H669-2	Engine Coolant - 50% Antifreeze, 50% Water Mixture	
E154-2	Coolant Heater, Extreme Cold Ambient	
H487-2	Engine Oil Heater - 120 Volts AC, Single Phase	
H706-2	Engine Oil	
L028-2	Genset Warranty - 2 Years Base	
L050-2	Literature - English	
A322-2	Packing - Skid, Poly Bag	
F065-2	Battery Rack	
H268-2	Extension - Oil Drain	
L260-2	Green Sound Level 2 Intake Baffle - Ship Loose	
A071T341-FRD	Enclosure Kit-Sound Level 2 Duct	
0503-2121	Fuel Connection Kit, Flexible-2"NPT, Gaseous, 30"L	1



GAS SUPPLY DESIGN BEST PRACTICES

Required:

1. The required fuel pressure and volume **must** be available under **all** operating conditions at the generator set gas inlet (see Location A on Figure 1 for measurement point).
2. The generator must have a dedicated pipe run from the meter, not teed off from other equipment supply pipes.
3. Braided flex piping and dry gas filters are required elements of the piping design, but if improperly sized can be highly restrictive to flow. These components and other restrictive portions of the piping system (valves, elbows, etc.) can, and often should be sized larger than the genset fuel connection.
4. A 'pilot' style regulator should never be used, as they are slow to respond to changes in demand from the generator set.

Recommended:

1. Long pipe runs increase pressure drop, so shorter is better. Elbows & valves increase restriction to flow, piping should be designed with as few of these as possible.
2. It is important to have the final pressure regulator as close to the generator inlet as practical. This allows for higher pressure in the line, as well as helps keep a steady draw on the line during operation.

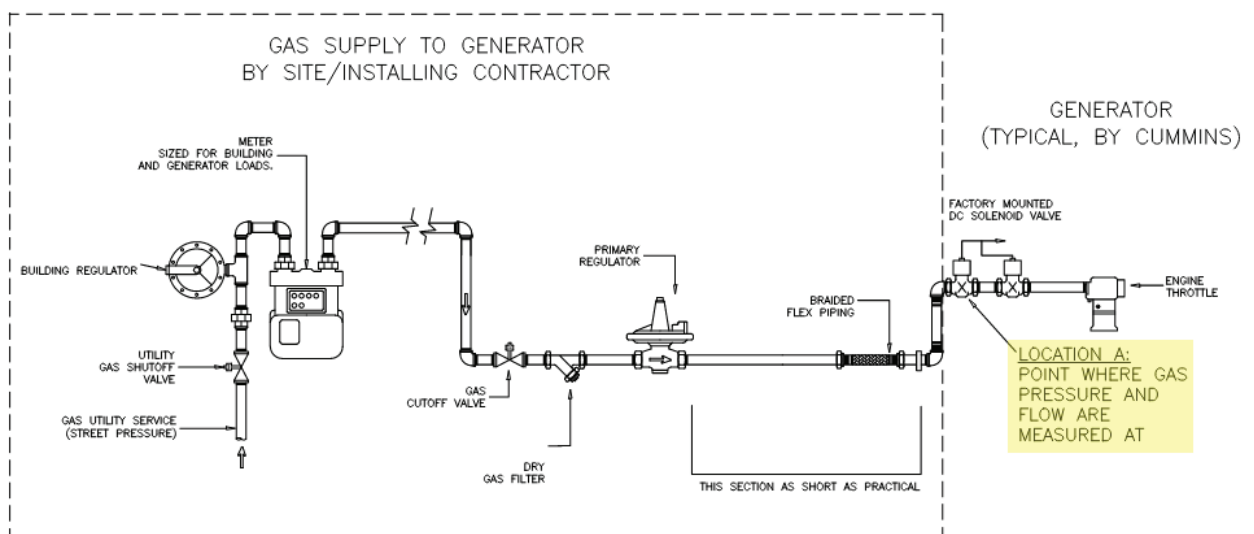

Figure 1. Typical site design



All gas supply piping must be designed by the appropriate engineer and installed by a qualified contractor. Refer to **NFPA 54** for gas pipe sizing information and any related local jurisdiction documents for code compliance on fuel piping installation.

Gas Fuel supply requirements for this generator set:

Fuel source:

NG

PV

Fuel consumption at 100% load: SCFH

Required Operating fuel pressure: in H₂O

Pressure is measured at the engine inlet solenoid, after the final regulator

Please note: The pressure listed is not a static pressure. If the above pressure is not maintained while the generator set is operating up to full load, the system will not function as required and the fuel delivery system will need to be corrected to provide operating pressure as listed.

All generators must be installed with a flexible fuel line and fuel strainer prior to the engine connection (**installation by others**):

Provided by Cummins

Provided by others

Flexible fuel line:

Fuel strainer:

Pressure regulator:

If provided by Cummins, see drawings in submittal for flex line and strainer sizing

Contact your Cummins representative for technical assistance.

SECTION 2

Generator Specifications





Spark-Ignited Generator set

125, 150, 175, & 200 kW
Standby
EPA Emissions



Description

Cummins Power Generation generator sets are fully integrated power generation systems providing optimum performance, reliability and versatility for stationary standby applications.

Features

Gas engine - Rugged 6-cylinder Cummins QSJ8.9G spark-ignited engine delivers reliable power. The electronic air/fuel ratio control provides optimum engine performance and fast response to load changes.

Alternator - Several alternator sizes offer selectable motor starting capability with low reactance 2/3 pitch windings, low waveform distortion with non-linear loads and fault clearing short-circuit capability.

Control system - The PowerCommand® 2.3 electronic control is standard equipment and provides total generator set system integration including automatic remote starting/stopping, precise frequency and voltage regulation, alarm and status message display, output metering, auto-shutdown at fault detection and NFPA 110 Level 1 compliance.

Cooling system - Standard cooling package provides reliable running at up to 50 °C (122 °F) ambient temperature.

Enclosures - The aesthetically appealing enclosure incorporates special designs that deliver one of the quietest generators of its kind. Aluminum material plus durable powder coat paint provides the best anti-corrosion performance. The generator set enclosure has been evaluated to withstand 180 MPH wind loads in accordance with ASCE7-10. The design has hinged doors to provide easy access for service and maintenance.

NFPA - The generator set accepts full rated load in a single step in accordance with NFPA 110 for Level 1 systems.

Warranty and service - Backed by a comprehensive warranty and worldwide distributor and dealer network.

Model	Natural Gas		Data sheets
	Standby (60 Hz)		
	kW	kVA	60 Hz
C125N6	125	156	NAD-6303
C150N6	150	188	NAD-6304
C175N6B	175	218	NAD-6632
C200N6B	200	250	NAD-6633

Generator Set Specifications

Governor regulation class	ISO 8528 Part 1 Class G3
Voltage regulation, no load to full load	± 1.0%
Random voltage variation	± 1.0%
Frequency regulation	Isochronous
Random frequency variation	± 0.25% @ 60 Hz
Radio frequency emissions compliance	FCC code title 47 part 15 class B

Engine Specifications

Design	Turbocharged and Aftercooled
Bore	114.1 mm (4.49 in)
Stroke	144.5 mm (5.69 in)
Displacement	8.9 liters (543 in ³)
Cylinder block	Cast iron, in-line 6 cylinder
Battery capacity	850 amps standard, dual battery optional
Battery charging alternator	100 amps
Starting voltage	12-volt, negative ground
Lube oil filter type(s)	Spin-on
Standard cooling system	125 kW - 50 °C (122 °F) ambient cooling system 150 kW - 45 °C (113 °F) ambient cooling system 175 kW - 50° C (122° F) ambient cooling system 200 kW - 45° C (113° F) ambient cooling system
Rated speed	1800 rpm

Alternator Specifications

Design	Brushless, 4 pole, drip proof, revolving field
Stator	2/3 pitch
Rotor	Direct coupled, flexible disc
Insulation system	Class H per NEMA MG1-1.65
Standard temperature rise	120 °C (248 °F) standby
Exciter type	Torque match (shunt) with PMG as option
Alternator cooling	Direct drive centrifugal blower
AC waveform total harmonic distortion	< 5% no load to full linear load, < 3% for any single harmonic
Telephone influence factor (TIF)	< 50 per NEMA MG1-22.43
Telephone harmonic factor (THF)	< 3%

Available Voltages

1-phase	3-phase
• 120/240	• 120/208 • 120/240 • 277/480 • 347/600 • 127/220

Generator Set Options

Fuel system

- 125 and 150 kW:
 - Single fuel – natural gas or propane vapor, field selectable
 - Dual fuel – natural gas or propane vapor, auto changeover
- 175 and 200 kW:
 - Single fuel – natural gas
- Low fuel gas pressure warning

Engine

- Normal or Heavy-duty engine air cleaner
- Shut down – low oil pressure
- Extension – oil drain
- Engine oil heater

Electrical

- One, two or three circuit breaker configurations
- 80% rated circuit breakers
- 100% rated LSI circuit breakers

Control

- PC2.3 with AmpSentry
- PC3.3 with Paralleling option
- AC output analog meters
- Stop switch – emergency
- Auxiliary output relays (2)
- Auxiliary configurable signal inputs (8) and relay outputs (8)

Alternator

- 120 °C temperature rise alternator
- 105 °C temperature rise alternator
- PMG
- Alternator heater, 120V Reconnectable full 1 phase output alternator

Enclosure

- Aluminum enclosures with muffler installed – green color
 - Weather
 - Sound Level 1
 - Sound Level 2
 - Winter

Cooling system

- Shutdown – low coolant level
- Warning – low coolant level
- Extension – coolant drain
- Coolant heater options:
 - < 4 °C (40 °F) - Cold weather
 - < -17 °C (0 °F) - Extreme cold

Exhaust system

- Exhaust connector NPT
- Exhaust muffler mounted

Generator set application

- Base barrier – elevated genset
- Battery rack, single or dual battery
- Radiator outlet duct adapter

Warranty

- Base warranty – 2 year / 1000 hours, standby
- 3-year standby warranty options
- 5-year standby warranty options

Generator Set Accessories

- Coolant heaters – 1500W / 2000W
- Battery rack, single or dual battery
- Battery heater kit
- Engine oil heater
- Remote control displays
- Auxiliary output relays (2)
- Auxiliary configurable signal inputs (8) and relay outputs (8)
- Annunciator – RS485

- Remote monitoring device – PowerCommand 500/550
- Battery charger – stand-alone, 12V
- Circuit breakers
- Enclosure Sound Level 1 to Sound Level 2 upgrade kit
- Base barrier – elevated generator set
- Mufflers – industrial, residential, or critical
- Alternator PMG
- Alternator heater

Control System PowerCommand 2.3



An integrated generator set control system providing voltage regulation, engine protection and operator interface.

Power Management - Provides battery monitoring and testing features and smart-starting control system.

InPower™ – PC-based service tool available for detailed diagnostics.

PCCNet RS485 - Network interface (standard) to devices such as remote annunciator for NFPA 110 applications.

Control boards - Potted for environmental protection.

Ambient operation - Suitable for operation in ambient temperatures from -40 °C to +70 °C and altitudes to 13,000 feet (5,000 meters).

AC Protection

- AmpSentry protective relay
- Over current warning and shutdown
- Over and under voltage shutdown
- Over and under frequency shutdown
- Over excitation (loss of sensing) fault
- Field overload
- Overload warning
- Reverse kW shutdown
- Reverse VAR shutdown
- Short circuit protection

Engine protection

- Overspeed shutdown
- Low oil pressure warning and shutdown
- High coolant temperature warning and shutdown
- Low coolant level warning or shutdown
- Low coolant temperature warning
- High, low and weak battery voltage warning
- Fail to start (overcrank) shutdown
- Fail to crank shutdown
- Redundant start disconnect
- Cranking lockout
- Sensor failure indication
- Low fuel level warning or shutdown
- Emergency stop
- Fuel-in-rupture-basin warning or shutdown

Operator/display panel

- Manual off switch
- 320 x 240 Pixels graphic LED backlight LCD with push button access for viewing engine and alternator data and providing setup, controls, and adjustments (English, Spanish, or French).
- LED lamps indicating genset running, not in auto, common warning, common shutdown, manual run mode and remote start
- Suitable for operation in ambient temperatures from -20 °C to +70 °C

Alternator data

- Line-to-line and Line-to-neutral AC volts
- 3-phase AC current
- Frequency
- Total kVa

Engine data

- DC voltage
- Lube oil pressure
- Coolant temperature
- Engine speed

Other data

- Generator set model data
- Start attempts, starts, running hours
- Fault history
- RS485 Modbus® interface
- Data logging and fault simulation (requires InPower service tool)

Digital governing (optional)

- Integrated digital electronic isochronous governor
- Temperature dynamic governing

Digital voltage regulation

- Integrated digital electronic voltage regulator
- 2-phase line-to-line sensing
- Configurable torque matching

Control functions

- Time delay start and cooldown
- Cycle cranking
- PCCNet interface
- (2) Configurable inputs
- (2) Configurable outputs
- Remote emergency stop
- Automatic transfer switch (ATS) control
- Generator set exercise, field adjustable

Options

- Auxiliary output relays (2)
- Remote annunciator with (3) configurable inputs and (4) configurable outputs
- PMG alternator excitation
- PowerCommand 500/550 for remote monitoring and alarm notification (accessory)
- Auxiliary, configurable signal inputs (8) and configurable relay outputs (8)
- Digital governing
- AC output analog meters (bargraph)
 - Color-coded graphical display of:
 - 3-phase AC voltage
 - 3-phase current
 - Frequency
 - kVa
- Remote operator panel

For further detail on PC 2.3, see document S-1569

For further detail on PC 3.3, see document S-1570

Ratings Definitions

Emergency standby power (ESP):

Applicable for supplying power to varying electrical load for the duration of power interruption of a reliable utility source. Emergency Standby Power (ESP) is in accordance with ISO 8528. Fuel Stop power in accordance with ISO 3046, AS 2789, DIN 6271 and BS 5514.

Limited-time running power (LTP):

Applicable for supplying power to a constant electrical load for limited hours. Limited Time Running Power (LTP) is in accordance with ISO 8528.

Prime power (PRP):

Applicable for supplying power to varying electrical load for unlimited hours. Prime Power (PRP) is in accordance with ISO 8528. Ten percent overload capability is available in accordance with ISO 3046, AS 2789, DIN 6271 and BS 5514.

Base load (continuous) power (COP):

Applicable for supplying power continuously to a constant electrical load for unlimited hours. Continuous Power (COP) in accordance with ISO 8528, ISO 3046, AS 2789, DIN 6271 and BS 5514.

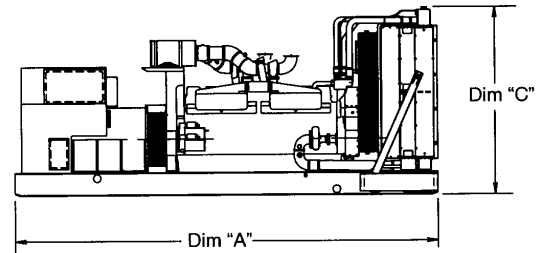
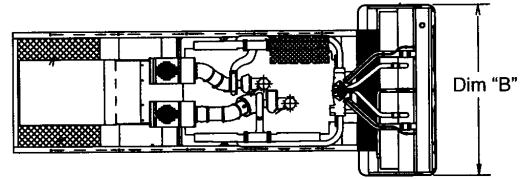

This outline drawing is for reference only. See respective model data sheet for specific model outline drawing number.

Do not use for installation design





Refer to drawings for specific weights & dimensions

Model	Dim "A" mm (in.)	Dim "B" mm (in.)	Dim "C" mm (in.)	Set Weight* wet kg (lbs.)
Open Set				
C125N6	2867 (113)	1016 (40)	1415 (56)	1580 (3483)
C150N6	2867 (113)	1016 (40)	1415 (56)	1580 (3483)
C175N6B	2867 (113)	1016 (40)	1478 (58)	1610 (3543)
C200N6B	2867 (113)	1016 (40)	1478 (58)	1698 (3735)
Weather Protective Enclosure				
C125N6	2867 (113)	1016 (40)	1836 (72)	1661 (3662)
C150N6	2867 (113)	1016 (40)	1836 (72)	1661 (3662)
C175N6B	2867 (113)	1016 (40)	1836 (72)	1691 (3728)
C200N6B	2867 (113)	1016 (40)	1836 (72)	1779 (3922)
Sound Attenuated Enclosure Level 1				
C125N6	3621 (143)	1016 (40)	1836 (72)	1776 (3915)
C150N6	3621 (143)	1016 (40)	1836 (72)	1776 (3915)
C175N6B	3621 (143)	1016 (40)	1836 (72)	1806 (3982)
C200N6B	3621 (143)	1016 (40)	1836 (72)	1894 (4176)
Sound Attenuated Enclosure Level 2				
C125N6	4061 (160)	1016 (40)	1836 (72)	1791 (3940)
C150N6	4061 (160)	1016 (40)	1836 (72)	1791 (3940)
C175N6B	4061 (160)	1016 (40)	1836 (72)	1821 (4015)
C200N6B	4061 (160)	1016 (40)	1836 (72)	1909 (4209)

* Weights above are average. Actual weight varies with product configuration

Codes and Standards

Codes or standards compliance may not be available with all model configurations – consult factory for availability.

 <p>The Prototype Test Support (PTS) program verifies the performance integrity of the generator set design. Cummins Power Generation products bearing the PTS symbol meet the prototype test requirements of NFPA 110 for Level 1 systems.</p>	 <p>This generator set is designed in facilities certified to ISO 9001 and manufactured in facilities certified to ISO 9001 or ISO 9002.</p>
<p>International Building Code</p> <p>The generator set is certified to International Building Code (IBC) 2012.</p>	 <p>The generator set is available Listed to UL 2200, Stationary Engine Generator Assemblies.</p>
	 <p>All low voltage models are CSA certified to product class 4215-01.</p>
	<p>U.S. EPA</p> <p>Engine certified to U.S. EPA SI Stationary Emission Regulation 40 CFR, Part 60.</p>

Warning: Back feed to a utility system can cause electrocution and/or property damage. Do not connect to any building's electrical system except through an approved device or after building main switch is open.

North America
1400 73rd Avenue N.E.
Minneapolis, MN 55432
USA

Phone 763 574 5000
 Fax 763 574 5298

Our energy working for you.™

©2022 Cummins All rights reserved.
 Cummins is a registered trademarks of Cummins Inc. PowerCommand, AmpSentry, InPower and "Our energy working for you." are trademarks of Cummins. Other company, product, or service names may be trademarks or service marks of others. Specifications are subject to change without notice.
 NAS-6298-EN (12/22) A057Y417



power.cummins.com

Generator Set Data Sheet



Model: C200N6B
Frequency: 60 Hz
Fuel type: Natural Gas
kW rating: 200 Natural Gas Standby

Emissions level: EPA Emissions

Fuel Consumption	Natural Gas Standby			
	kW (kVA)			
Ratings	200 (250)			
Load	1/4	1/2	3/4	Full
scfh	834.1	1442.4	1961.2	2599.1
m ³ /hr	23.62	40.85	55.54	73.61

Engine	Natural Gas Standby Rating
Engine model	QSJ8.9G-G3
Configuration	Cast Iron, In line, 6 cylinders
Aspiration	Turbocharged and aftercooled
Gross engine power output, kWm (bhp)	231 (310)
Bore, mm (in)	114.1 (4.49)
Stroke, mm (in)	144.5 (5.69)
Rated speed, rpm	1800
Compression ratio	8.5:1
Lube oil capacity, L (qt)	21 (22)

Fuel Supply Pressure	
Minimum operating pressure, kPa (in H ₂ O)	1.5 (6)
Maximum operating pressure, kPa (in H ₂ O)	3.5 (14)

Air	Natural Gas Standby Rating
Combustion air, m ³ /min (scfm)	17 (600)
Maximum normal duty air cleaner restriction, kPa (in H ₂ O)	3.7 (15.0)
Maximum heavy-duty air cleaner restriction, kPa (in H ₂ O)	3.7 (15.0)

Exhaust	Natural Gas Standby Rating
Exhaust flow at set rated load, m ³ /min (cfm)	39.6 (1399.5)
Exhaust temperature at set rated load, °C (°F)	588.9 (1092)
Maximum back pressure, kPa (inH ₂ O)	9 (36.1)

Standard set-mounted radiator cooling	Natural Gas Standby Rating
Ambient design, °C (°F)	50 (122)
Fan load, kWm (HP)	10.1 (13.5)
Coolant capacity (with radiator), L (US gal)	21 (5.6)
Cooling system air flow, m ³ /min (scfm)	368.1 (13000)
Maximum cooling air flow static restriction, kPa (inH ₂ O)	0.125 (0.5)

Weights

Unit wet weight kg (lb)

Refer to drawings for specific weights & dimensions

Note: Weights represent a set with standard features. See outline drawing for weights of other configurations.

Derating factors

Natural Gas	
Standby	Engine power available up to 600 m (1969 ft) and ambient temperatures up to 40° C (104° F). Above these conditions, derate at 3.2% per 300 m (985 ft) and 2.5% per 5.5° C (10° F).

Ratings definitions

Emergency Standby Power (ESP)	Limited-Time Running Power (LTP)	Prime Power (PRP)	Base Load (Continuous) Power (COP)
Applicable for supplying power to varying electrical load for the duration of power interruption of a reliable utility source. Emergency Standby Power (ESP) is in accordance with ISO 8528. Fuel Stop power in accordance with ISO 3046, AS 2789, DIN 6271 and BS 5514.	Applicable for supplying power to a constant electrical load for limited hours. Limited Time Running Power (LTP) is in accordance with ISO 8528.	Applicable for supplying power to varying electrical load for unlimited hours. Prime Power (PRP) is in accordance with ISO 8528. Ten percent overload capability is available in accordance with ISO 3046, AS 2789, DIN 6271 and BS 5514.	Applicable for supplying power continuously to a constant electrical load for unlimited hours. Continuous Power (COP) is in accordance with ISO 8528, ISO 3046, AS 2789, DIN 6271 and BS 5514.

Alternator data

Standard alternators	Single phase table	Three phase table				
Maximum temperature rise above 40° C ambient	120° C	120° C				
Feature code	BB90-2	B946-2	B986-2	B952-2	B943-2	BB86-2
Alternator data sheet number	ADS-213	ADS-213	ADS-212	ADS-212	ADS-212	ADS-212
Voltage ranges	120/240	120/208	120/240	347/600	277/480	127/220
Voltage feature code	R104-2	R098-2	R106-2	R114-2	R002-2	R020-2
Surge kW	205.7	211.1	213.4	214.3	213.4	211.6
Motor Starting kVA (at 90% sustained voltage) Shunt	770	770	672	770	770	770
Motor Starting kVA (at 90% sustained voltage) PMG	920	920	791	920	920	920
Full load current amps at standby rating	833	694	602	240	301	656

Optional alternators for improved starting capability	Three phase table				
Maximum temperature rise above 40 °C ambient	105° C				
Feature code	BB94-2	BB95-2	BB92-2	BB85-2	BB93-2
Alternator data sheet number	ADS-212	ADS-212	ADS-212	ADS-212	ADS-213
Voltage ranges	120/240	277/480	347/600	127/220	120/208
Voltage feature code	R106-2	R002-2	R114-2	R020-2	R098-2
Surge kW	213.4	213.4	214.3	211.6	211.1
Motor Starting kVA (at 90% sustained voltage) Shunt	770	770	770	770	770
Motor Starting kVA (at 90% sustained voltage) PMG	920	920	920	920	920
Full load current amps at standby rating	602	301	240	656	694

Notes:

¹ Single phase power can be taken from a three phase generator set at up to 2/3 set rated 3-phase kW at 1.0 power factor

² Full single phase output up to full set rated 3-phase kW at 1.0 power factor

Formulas for calculating full load currents:

Three phase output

$$\frac{\text{kW} \times 1000}{\text{Voltage} \times 1.73 \times 0.8}$$

Single phase output

$$\frac{\text{kW} \times \text{SinglePhaseFactor} \times 1000}{\text{Voltage}}$$

Warning: Back feed to a utility system can cause electrocution and/or property damage. Do not connect to any buildings electrical system except through an approved device or after building main switch is open.

North America
1400 73rd Avenue N.E.
Minneapolis, MN 55432
USA

Phone 763 574 5000
Fax 763 574 5298

Our energy working for you.™

©2022 Cummins All rights reserved.

Cummins is a registered trademarks of Cummins Inc. PowerCommand, AmpSentry, InPower and "Our energy working for you." are trademarks of Cummins. Other company, product, or service names may be trademarks or service marks of others. Specifications are subject to change without notice.

NAD-6633-EN (12/22) PD00001228 (Last Edited: 5/22/24)



PowerCommand® 2.3 Control System



Control System Description

The PowerCommand control system is a microprocessor-based generator set monitoring, metering and control system designed to meet the demands of today's engine driven generator sets. The integration of all control functions into a single control system provides enhanced reliability and performance, compared to conventional generator set control systems. These control systems have been designed and tested to meet the harsh environment in which gensets are typically applied.

Features

- 320 x 240 pixels graphic LED backlight LCD.
- Multiple language support.
- AmpSentry™ protective relay - true alternator overcurrent protection.
- Real time clock for fault and event time stamping.
- Exerciser clock and time of day start/stop.
- Digital voltage regulation. Three phase full wave FET type regulator compatible with either shunt or PMG systems.
- Generator set monitoring and protection.
- 12 and 24 VDC battery operation.
- Modbus® interface for interconnecting to customer equipment.
- Warranty and service. Backed by a comprehensive warranty and worldwide distributor service network.
- Certifications - suitable for use on generator sets that are designed, manufactured, tested and certified to relevant UL, NFPA, ISO, IEC, Mil Std., CE, UKCA and CSA standards.

PowerCommand Digital Genset Control PCC 2300



Description

The PowerCommand generator set control is suitable for use on a wide range of generator sets in non-parallel applications. The PowerCommand control is compatible with shunt or PMG excitation style. It is suitable for use with reconnectable or non-reconnectable generators, and it can be configured for any frequency, voltage and power connection from 120-600 VAC Line-to-Line.

Power for this control system is derived from the generator set starting batteries. The control functions over a voltage range from 8 VDC to 30 VDC.

Features

- 12 and 24 VDC battery operation.
- Digital voltage regulation - Three phase full wave FET type regulator compatible with either shunt or PMG systems. Sensing is three phase.
- Full authority engine communications (where applicable) - Provides communication and control with the Engine
- due to thermal Control Module (ECM).
- AmpSentry™ protection provides industry-leading alternator overcurrent protection:
 - Time-based generator protection applicable to both line-to-line and line-to-neutral, that can detect an unbalanced fault condition and swiftly react appropriately. Balanced faults can also be detected by AmpSentry and appropriate acted upon.
- Reduces the risk of Arc Flash overload or electrical faults by inverse time protection
- Common harnessing - with higher feature Cummins controls. Allows for easy field upgrades.
- Generator set monitoring - Monitors status of all critical engine and alternator functions.
- Digital genset metering (AC and DC).
- Genset battery monitoring system to sense and warn against a weak battery condition.
- Configurable for single or three phase AC metering.
- Engine starting - Includes relay drivers for starter, Fuel Shut Off (FSO), glow plug/spark ignition power and switch B+ applications.
- Generator set protection – Protects engine and alternator.
- Real time clock for fault and event time stamping.
- Exerciser clock and time of day start/stop.
- Advanced serviceability - using InPower™, a PC-based software service tool.

- Environmental protection - The control system is designed for reliable operation in harsh environments. The main control board is a fully encapsulated module that is protected from the elements.
- Modbus interface for interconnecting to customer equipment.
- Configurable inputs and outputs - Four discrete inputs and four dry contact relay outputs.
- Warranty and service - Backed by a comprehensive warranty and worldwide distributor service network.
- Certifications - Suitable for use on generator sets that are designed, manufactured, tested and certified to relevant UL, NFPA, ISO, IEC, Mil Std., CE and CSA standards.

Base Control Functions

HMI Capability

Operator adjustments - The HMI includes provisions for many set up and adjustment functions.

Generator set hardware data - Access to the control and software part number, generator set rating in kVA and generator set model number is provided from the HMI or InPower.

Data logs - Includes engine run time, controller on time, number of start attempts, total kWh, and load profile (control logs data indicating the operating hours at percent of rated kW load, in 5% increments. The data is presented on the operation panel based on total operating hours on the generator.)

Fault history - Provides a record of the most recent fault conditions with control date and time stamp. Up to 32 events are stored in the control non-volatile memory.

Alternator data

- Voltage (single or three phase Line-to-Line and Line-to-Neutral)
- Current (single or three phase)
- kW, kVar, power factor, kVA (three phase and total)
- Frequency

AmpSentry: 3x current regulation for downstream tripping/motor inrush management. Thermal damage curve (3-phase short) or fixed timer (2 sec for 1- Phase Short or 5 sec for 2-Phase short).

Engine data

- Starting battery voltage
- Engine speed
- Engine temperature
- Engine oil pressure
- Engine oil temperature
- Intake manifold temperature
- Comprehensive Full Authority Engine (FAE) data (where applicable)

Service adjustments - The HMI includes provisions for adjustment and calibration of generator set control functions. Adjustments are protected by a password. Functions include:

Service adjustments (continued)

- Engine speed governor adjustments
- Voltage regulation adjustments
- Cycle cranking
- Configurable fault set up
- Configurable output set up
- Meter calibration
- Display language and units of measurement

Engine Control

SAE-J1939 CAN interface to full authority ECMs (where applicable). Provides data swapping between genset and engine controller for control, metering and diagnostics.

12 VDC/24 VDC battery operations - PowerCommand will operate either on 12 VDC or 24 VDC batteries.

Temperature dependent governing dynamics (with electronic governing) - modifies the engine governing control parameters as a function of engine temperature. This allows the engine to be more responsive when warm and more stable when operating at lower temperature levels.

Isochronous governing - (where applicable) Capable of controlling engine speed within +/-0.25% for any steady state load from no load to full load. Frequency drift will not exceed +/-0.5% for a 33 °C (60 °F) change in ambient temperature over an 8 hour period.

Droop electronic speed governing - Control can be adjusted to droop from 0 to 10% from no load to full load.

Remote start mode - It accepts a ground signal from remote devices to automatically start the generator set and immediately accelerate to rated speed and voltage. The remote start signal will also wake up the control from sleep mode. The control can incorporate a time delay start and stop.

Remote and local emergency stop - The control accepts a ground signal from a local (genset mounted) or remote (facility mounted) emergency stop switch to cause the generator set to immediately shut down. The generator set is prevented from running or cranking with the switch engaged. If in sleep mode, activation of either emergency stop switch will wake up the control.

Sleep mode - The control includes a configurable low current draw state to minimize starting battery current draw when the genset is not operating. The control can also be configured to go into a low current state while in auto for prime applications or applications without a battery charger.

Engine starting - The control system supports automatic engine starting. Primary and backup start disconnects are achieved by one of two methods: magnetic pickup or main alternator output frequency. The control also supports configurable glow plug control when applicable.

Cycle cranking - Is configurable for the number of starting cycles (1 to 7) and duration of crank and rest periods. Control includes starter protection algorithms to prevent the operator from specifying a starting sequence that might be damaging.

Time delay start and stop (cooldown) - Configurable for time delay of 0-300 seconds prior to starting after receiving a remote start signal and for time delay of 0-600 seconds prior to shut down after signal to stop in normal operation modes. Default for both time delay periods is 0 seconds.

Alternator Control

The control includes an integrated three phase Line-to-Line sensing voltage regulation system that is compatible with shunt or PMG excitation systems. The voltage regulation system is a three phase full wave rectified and has an FET output for good motor starting capability.

Major system features include:

Digital output voltage regulation - Capable of regulating output voltage to within +/-1.0% for any loads between no load and full load. Voltage drift will not exceed +/- 1.5% for a 40 °C (104 °F) change in temperature in an eight hour period. On engine starting or sudden load acceptance, voltage is controlled to a maximum of 5% overshoot over nominal level. The automatic voltage regulator feature can be disabled to allow the use of an external voltage regulator.

Droop voltage regulation - Control can be adjusted to droop from 0-10% from no load to full load.

Torque-matched V/Hz overload control - The voltage roll-off set point and rate of decay (i.e. the slope of the V/Hz curve) is adjustable in the control.

Fault current regulation - PowerCommand will regulate the output current on any phase to a maximum of three times rated current under fault conditions for both single phase and three phase faults. In conjunction with a permanent magnet generator, it will provide three times rated current on all phases for motor starting and short circuit coordination purpose.

Protective Functions

On operation of a protective function the control will indicate a fault by illuminating the appropriate status LED on the HMI, as well as display the fault code and fault description on the LCD. The nature of the fault and time of occurrence are logged in the control. The service manual and InPower service tool provide service keys and procedures based on the service codes provided.

Protective functions include:

Battle Short Mode

When enabled and the *battle short* switch is active, the control will allow some shutdown faults to be bypassed. If a bypassed shutdown fault occurs, the fault code and description will still be annunciated, but the genset will not shutdown. This will be followed by a *fail to shutdown* fault. Emergency stop shutdowns and others that are critical for proper operation are not bypassed. Please refer to the control application guide or manual for list of these faults.

Derate

The derate function reduces output power of the genset in response to a fault condition. If a derate command occurs while operating on an isolated bus, the control will issue commands to reduce the load on the genset via contact closures or modbus.

Configurable Alarm and Status Inputs

The control accepts up to four alarm or status inputs (configurable contact closed to ground or open) to indicate a configurable (customer-specified) condition. The control is programmable for warning, shutdown or status indication and for labeling the input.

Emergency Stop

Annunciated whenever either emergency stop signal is received from external switch.

Full Authority Electronic Engine Protection

Engine fault detection is handled inside the engine ECM. Fault information is communicated via the SAE-J1939 data link for annunciation in the HMI.

General Engine Protection

Low and high battery voltage warning - Indicates status of battery charging system (failure) by continuously monitoring battery voltage.

Weak battery warning - The control system will test the battery each time the generator set is signaled to start and indicate a warning if the battery indicates impending failure.

Fail to start (overcrank) shutdown - The control system will indicate a fault if the generator set fails to start by the completion of the engine crank sequence.

Fail to crank shutdown - Control has signaled starter to crank engine but engine does not rotate.

Cranking lockout - The control will not allow the starter to attempt to engage or to crank the engine when the engine is rotating.

Alternator Protection

AmpSentry protective relay - A comprehensive monitoring and control system integral to the PowerCommand Control System that guards the electrical integrity of the alternator and power system by providing protection against a wide array of fault conditions in the generator set or in the load. It also provides single and three phase fault current regulation so that downstream protective devices have the maximum current available to quickly clear fault conditions without subjecting the alternator to potentially catastrophic failure conditions. Thermal damage curve (3-Phase short) or fixed timer (2 sec for 1-Phase short, 5 sec for 2-Phase short). See document R1053 for a full-size time over current curve.

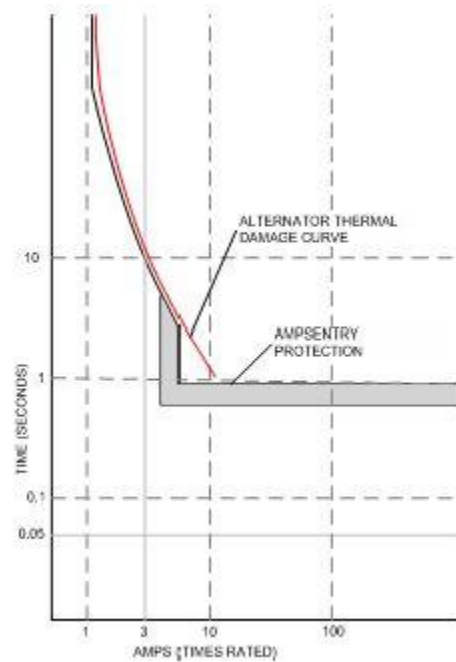

AmpSentry Maintenance Mode (AMM) - Instantaneous tripping, if AmpSentry Maintenance mode is active (50mS response to turn off AVR excitation/shutdown genset) for arc flash reduction when personnel are near genset.

High AC voltage shutdown (59) - Output voltage on any phase exceeds preset values. Time to trip is inversely proportional to amount above threshold. Values adjustable from 105-125% of nominal voltage, with time delay adjustable from 0.1-10 seconds. Default value is 110% for 10 seconds.

Low AC voltage shutdown (27) - Voltage on any phase has dropped below a preset value. Adjustable over a range of 50-95% of reference voltage, time delay 2-20 seconds. Default value is 85% for 10 seconds. Function tracks reference voltage. Control does not nuisance trip when voltage varies due to the control directing voltage to drop, such as during a V/Hz roll-off during synchronizing.

Under frequency shutdown (81 u) - Generator set output frequency cannot be maintained. Settings are adjustable from 2-10 Hz below reference governor set point, for a 5- 20 second time delay. Default: 6 Hz, 10 seconds.

Under frequency protection is disabled when excitation is switched off, such as when engine is operating in idle speed mode.

Over frequency shutdown/warning (81 o) - Generator set is operating at a potentially damaging frequency level. Settings are adjustable from 2-10 Hz above nominal governor set point for a 1-20 second time delay. Default: 6 Hz, 20 seconds, disabled.

Overcurrent warning/shutdown - Thresholds and time delays are configurable. Implementation of the thermal damage curve with instantaneous trip level calculated based on current transformer ratio and application power rating.

Loss of sensing voltage shutdown - Shutdown of generator set will occur on loss of voltage sensing inputs to the control.

Field overload shutdown - Monitors field voltage to shutdown generator set when a field overload condition occurs.

Over load (kW) warning - Provides a warning indication when engine is operating at a load level over a set point.

Adjustment range: 80-140% of application rated kW, 0-120 second delay. Defaults: 105%, 60 seconds.

Reverse power shutdown (32) - Adjustment range: 5-20% of standby kW rating, delay 1-15 seconds. Default: 10%, 3 seconds.

Reverse Var shutdown - Shutdown level is adjustable: 15-50% of rated Var output, delay 10-60 seconds. Default: 20%, 10 seconds.

Short circuit protection - Output current on any phase is more than 175% of rating and approaching the thermal damage point of the alternator. Control includes algorithms to protect alternator from repeated over current conditions over a short period of time.

Field Control Interface

Input signals to the PowerCommand control include:

- Coolant level (where applicable)
- Fuel level (where applicable)
- Remote emergency stop
- Remote fault reset
- Remote start
- Battleshort
- Rupture basin
- Start type signal
- Configurable inputs - Control includes (4) input signals from customer discrete devices that are configurable for warning, shutdown or status indication, as well as message displayed

Output signals from the PowerCommand control include:

- Load dump signal: Operates when the generator set is in an overload condition.
- Delayed off signal: Time delay based output which will continue to remain active after the control has removed the run command. Adjustment range: 0 – 120 seconds. Default: 0 seconds.

- Configurable relay outputs: Control includes (4) relay output contacts (3 A, 30 VDC). These outputs can be configured to activate on any control warning or shutdown fault as well as ready to load, not in auto, common alarm, common warning and common shutdown.

- Ready to load (generator set running) signal: Operates when the generator set has reached 90% of rated speed and voltage and latches until generator set is switched to off or idle mode.

Communications Connections Include:

- PC tool interface: This RS-485 communication port allows the control to communicate with a personal computer running InPower software.

- Modbus RS-485 port: Allows the control to communicate with external devices such as PLCs using Modbus protocol.

Note - An RS-232 or USB to RS-485 converter is required for communication between PC and control.

- Networking: This RS-485 communication port allows connection from the control to the other Cummins products.

Mechanical Drawings

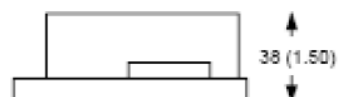
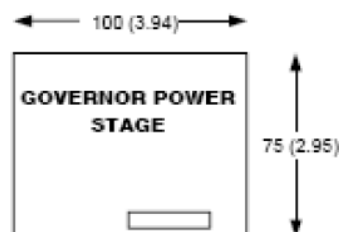
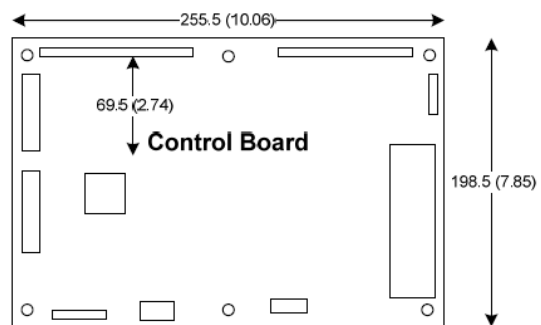

PowerCommand Human Machine Interface HMI320



Description

This control system includes an intuitive operator interface panel that allows for complete genset control as well as system metering, fault annunciation, configuration and diagnostics. The interface includes five genset status LED lamps with both internationally accepted symbols and English text to comply with customer's needs. The interface also includes an LED backlit LCD display with tactile feel soft-switches for easy operation and screen navigation. It is configurable for units of measurement and has adjustable screen contrast and brightness.

The *run/off/auto* switch function is integrated into the interface panel.

All data on the control can be viewed by scrolling through screens with the navigation keys. The control displays the current active fault and a time-ordered history of the five previous faults.

Features

- LED indicating lamps:
 - Genset running
 - Remote start
 - Not in auto
 - Shutdown
 - Warning
 - Auto
 - Manual and stop
- 320 x 240 pixels graphic LED backlight LCD.
- Four tactile feel membrane switches for LCD defined operation. The functions of these switches are defined dynamically on the LCD.
- Seven tactile feel membrane switches dedicated screen navigation buttons for up, down, left, right, ok, home and cancel.
- Six tactile feel membrane switches dedicated to control for auto, stop, manual, manual start, fault reset and lamp test/panel lamps.

- Two tactile feel membrane switches dedicated to control of circuit breaker (where applicable).
- Allows for complete genset control setup.
- Certifications: Suitable for use on generator sets that are designed, manufactured, tested and certified to relevant UL, NFPA, ISO, IEC, Mil Std., CE and CSA standards.
- LCD languages supported: English, Spanish, French, German, Italian, Greek, Dutch, Portuguese, Finnish, Norwegian, Danish, Russian and Chinese Characters.

Communications connections include:

- PC tool interface - This RS-485 communication port allows the HMI to communicate with a personal computer running InPower.
- This RS-485 communication port allows the HMI to communicate with the main control board.

Mechanical Drawing

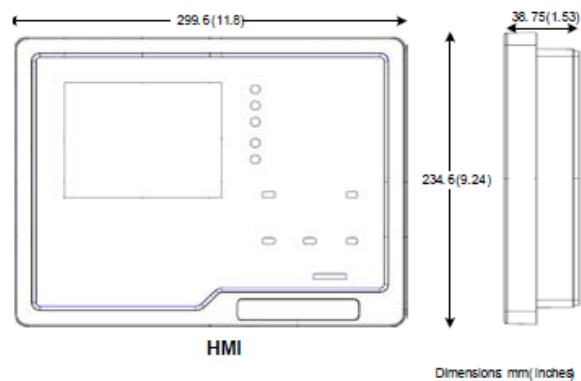

Software

InPower (beyond 6.5 version) is a PC-based software service tool that is designed to directly communicate to PowerCommand generator sets and transfer switches, to facilitate service and monitoring of these products.

Environment

The control is designed for proper operation without recalibration in ambient temperatures from -40 °C to +70 °C (-40 °F to 158 °F) and for storage from -55 °C to +80 °C (-67 °F to 176 °F). Control will operate with humidity up to 95%, non-condensing.

The HMI is designed for proper operation in ambient temperatures from -20 °C to +70 °C (-4 °F to 158 °F) and for storage from -30 °C to +80 °C (-22 °F to 176 °F).

The control board is fully encapsulated to provide superior resistance to dust and moisture. Display panel has a single membrane surface, which is impervious to effects of dust, moisture, oil and exhaust fumes. This panel uses a sealed membrane to provide long reliable service life in harsh environments.

The control system is specifically designed and tested for resistance to RFI/EMI and to resist effects of vibration to provide a long reliable life when mounted on a generator set. The control includes transient voltage surge suppression to provide compliance to referenced standards.

Certifications

PowerCommand meets or exceeds the requirements of the following codes and standards:

- NFPA 110 for level 1 and 2 systems.
- ISO 8528-4: 1993 compliance, controls and switchgear.
- CE marking: The CE marking is only valid when equipment is used in a fixed installation application. Material compliance declaration is available upon request.
- UKCA marking: The UKCA marking is only valid when equipment is used in a fixed installation application. Material compliance declaration is available upon request.
- EN50081-1,2 residential/light industrial emissions or industrial emissions.
- EN50082-1,2 residential/light industrial or industrial susceptibility.
- ISO 7637-2, level 2; DC supply surge voltage test.
- Mil Std 202C, Method 101 and ASTM B117: Salt fog test.
- UL 6200 recognized and suitable for use on UL 2200 Listed generator sets.
- CSA C282-M1999 compliance
- CSA 22.2 No. 14 M91 industrial controls.
- PowerCommand control systems and generator sets are designed and manufactured in ISO 9001 certified facilities.

Warranty

All components and subsystems are covered by an express limited one year warranty. Other optional and extended factory warranties and local distributor maintenance agreements are available.



**For more information contact your local Cummins distributor
or visit power.cummins.com**

Our energy working for you.™





Alternator data sheet

Frame size: **UCD3J**

Characteristics										
Weights:		Wound stator assembly:		670.205 lb		304 kg				
		Rotor assembly:		597.45 lb		271.9 kg				
		Complete alternator:		1602.76 lb		727 kg				
Maximum speed:				2250 rpm						
Excitation current:		Full load:		2.20 Amps						
		No load:		0.50 Amps						
Insulation system:		Class H throughout								
1 ∅ Ratings (1.0 power factor)		60 Hz (winding no)				50 Hz (winding no)				
(Based on specific temperature rise at 40 °C ambient temperature)		Double delta		4 lead		Double delta				
		<u>120/240</u>		<u>120/240</u>		110-120 <u>220-240</u>				
125 °C Rise ratings	kW/kVA	161/201		175/219		140/175				
105 °C Rise ratings	kW/kVA	150/188		157/196		126/158				
3 ∅ Ratings (0.8 power factor)		Upper broad range			LBR*	347/600	Broad range			
(Based on specified temperature rise at 40 °C ambient temperature)		120/208 <u>240/416</u>	127/220 <u>255/440</u>	139/240 <u>277/480</u>	190-208 <u>380-416</u>	<u>347/600</u>	110/190 <u>220/380</u>	115/200 <u>230/400</u>	120/208 <u>240/415</u>	127/220 <u>254/440</u>
150 °C Rise ratings	kW	230	240	255	255	230	200	200	200	172
	kVA	288	300	319	319	288	250	250	250	215
125 °C Rise ratings	kW	215	225	240	240	215	184	184	184	164
	kVA	269	281	300	300	269	230	230	230	205
105 °C Rise ratings	kW	200	211	220	220	200	168	168	168	148
	kVA	250	264	275	275	250	210	210	210	185
80 °C Rise ratings	kW	170	180	190	190	170	154	154	154	128
	kVA	213	225	238	238	213	193	193	193	160
3 ∅ Reactances (per unit, ±10%)		416	440	480	380	600	380	400	415	440
(Based on full load at 105 °C rise rating)										
Synchronous		2.651	2.457	2.221	2.00	2.00	1.939	1.75	1.626	N/A
Transient		0.164	0.153	0.137	0.13	0.13	0.103	0.093	0.086	N/A
Subtransient		0.096	0.09	0.08	0.07	0.07	0.07	0.064	0.059	N/A
Negative sequence		0.117	0.109	0.098	0.14	0.14	0.117	0.105	0.098	N/A
Zero sequence		0.048	0.045	0.04	0.04	0.04	0.044	0.04	0.037	N/A
3 ∅ Motor starting		Broad range			LBR*	600	Broad range			
Maximum kVA	(Shunt)	770			770	770	535			
(90% sustained voltage)	(PMG)	920			920	920	678			
Time constants (Sec)										
Transient		0.045		0.045	0.045		0.045			
Subtransient		0.015		0.015	0.015		0.015			
Open circuit		1.270		1.270	1.270		1.270			
DC		0.030		0.030	0.030		0.030			
Windings (@ 20° C)										
Stator resistance	(Ohms per phase)	0.0128		0.0128	0.0128		0.0128			
Rotor resistance	(Ohms)	2.0000		2.0000	2.0000		2.0000			
Number of leads		12		12	6		12			

* Lower broad range 110/190 thru 120/208, 220/380 thru 240/416.



Winding 311

THREE PHASE EFFICIENCY CURVES

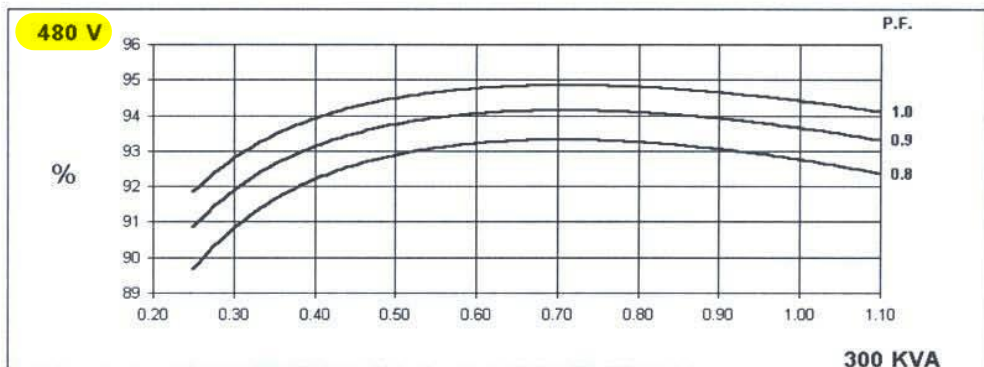
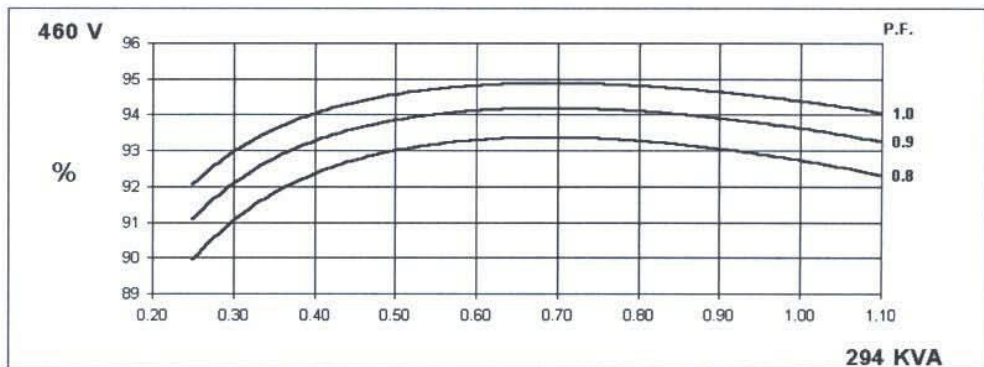
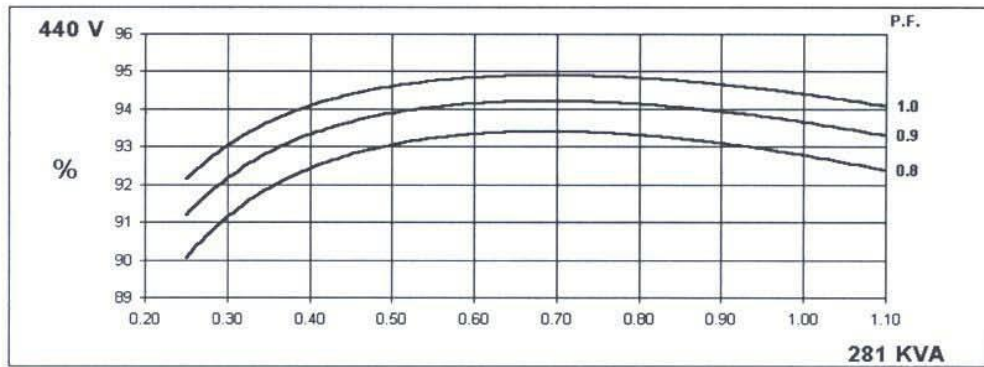
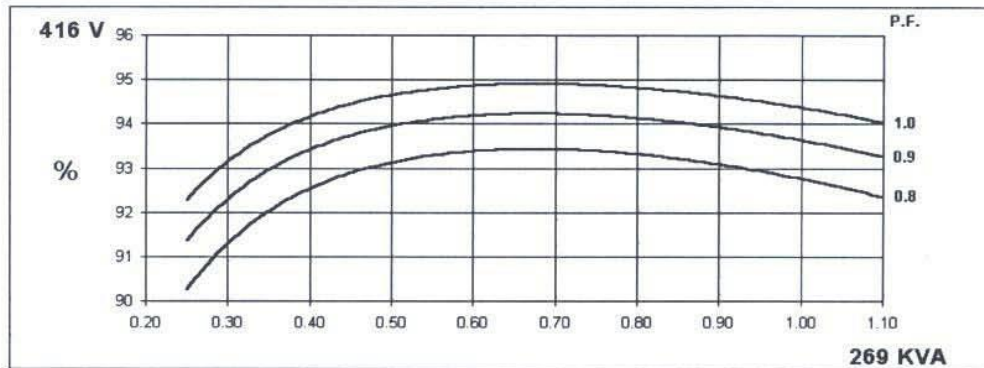



Alternator data sheet

Frame size: UCD3J

Three-phase Short Circuit Decrement Curve. No-load Excitation at Rated Speed
Based on star (wye) connection.

**50
Hz**

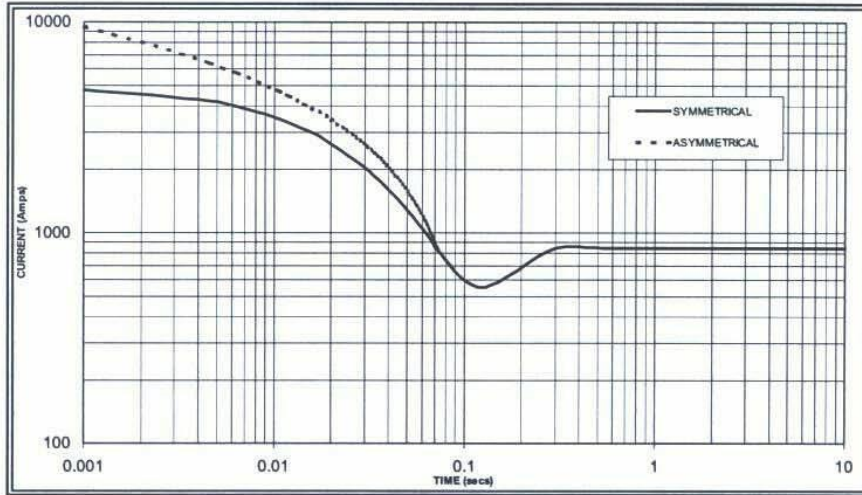

Sustained Short Circuit = 850 Amps

**60
Hz**

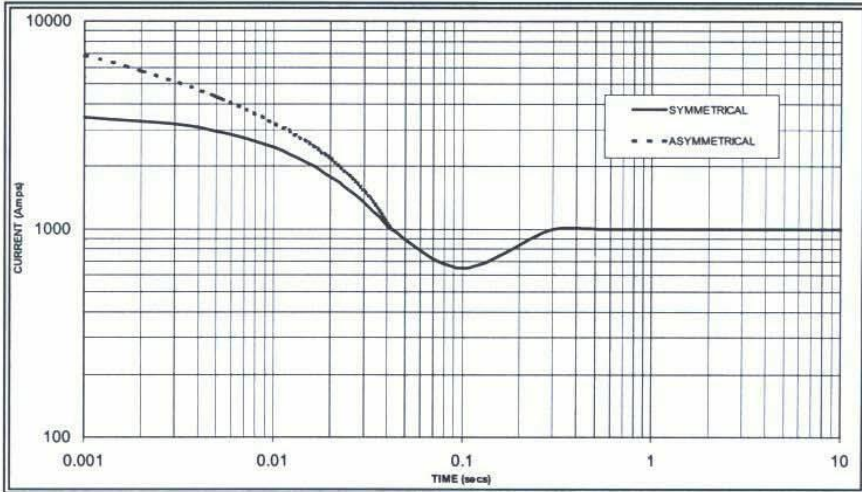

Sustained Short Circuit = 1.000 Amps

Note 1

The following multiplication factors should be used to adjust the values from curve between time 0.001 seconds and the minimum current point in respect of nominal operating voltage :

50Hz		60Hz	
Voltage	Factor	Voltage	Factor
380v	X 1.00	416v	X 1.00
400v	X 1.05	440v	X 1.07
415v	X 1.10	460v	X 1.12
440v	X 1.16	480v	X 1.16

The sustained current value is constant irrespective of voltage level

Note 2

The following multiplication factor should be used to convert the values calculated in accordance with NOTE 1 to those applicable to the various types of short circuit :

	3-phase	2-phase L-L	1-phase L-N
Instantaneous	x 1.00	x 0.87	x 1.30
Minimum	x 1.00	x 1.80	x 3.20
Sustained	x 1.00	x 1.50	x 2.50
Max. sustained duration	10 sec.	5 sec.	2 sec.

All other times are unchanged

Note 3

Curves are drawn for Star (Wye) connected machines. For other connection the following multipliers should be applied to current values as shown :

Parallel Star = Curve current value X 2

Series Delta = Curve current value X 1.732



Alternator data sheet

Frame size: UCD3J

Winding 311

Locked Rotor Motor Starting Curve

50 Hz

MX

SX

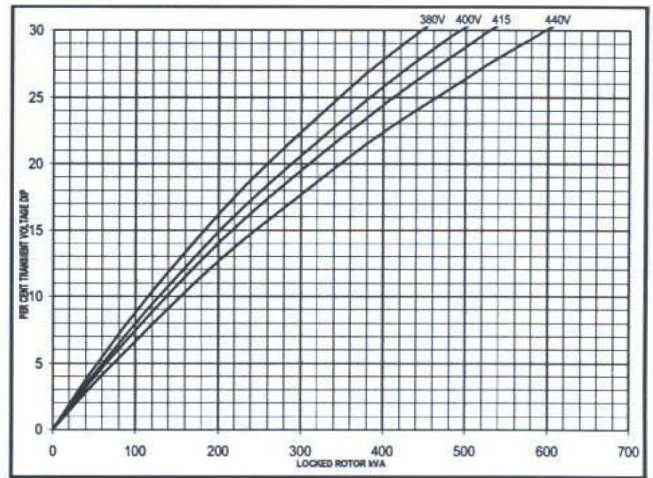
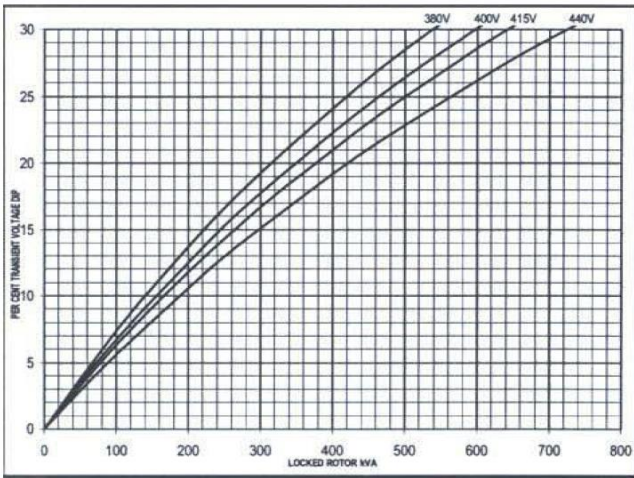

60 Hz

MX

SX

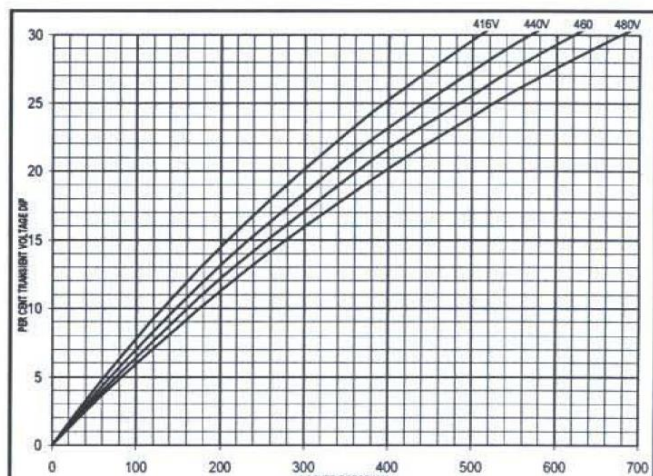
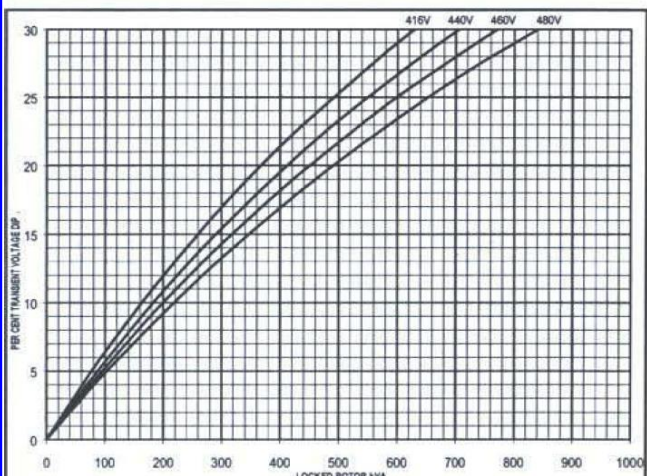



Sound Data

C200N6B

QSL8.9G-G3 60Hz Natural Gas

A-weighted Sound Pressure Level @ 7 meters, dB(A)

See notes 2, 5 and 7-11 listed below

Configuration	Exhaust	Applied Load	Position (Note 2)								8 Position Average
			1	2	3	4	5	6	7	8	
Standard - Unhoused	Infinite Exhaust	100% Standby	89.0	89.4	89.5	90.1	89.7	90.3	89.0	89.2	89.5
F216-2 Weather Protective Aluminium	Mounted	100% Standby	86.5	84.3	80.8	87.2	84.3	90.2	83.8	86.5	86.2
F231-2 Sound Attenuated Level 1, Aluminium	Mounted	100% Standby	83.7	79.7	75.7	77.3	77.8	78.1	76.2	79.2	79.2
F217-2 Sound Attenuated Level 2, Aluminium	Mounted	100% Standby	75.2	74.1	72.8	74.1	75.2	75.4	73.4	74.7	74.4

Average A-weighted Sound Pressure Level @ 1 meter, dB(A)

See notes 1, 5 and 7-14 listed below

Configuration	Exhaust	Applied Load	Octave Band Center Frequency (Hz)											Overall Sound Pressure Level
			16	31.5	63	125	250	500	1000	2000	4000	8000	16000	
Standard - Unhoused	Infinite Exhaust	100% Standby	11.0	33.7	48.7	66.3	76.1	80.5	85.8	86.0	82.1	83.9	73.5	99.0
F216-2 Weather Protective Aluminium	Mounted	100% Standby	23.3	37.7	51.5	65.9	79.1	82.7	85.5	89.3	85.5	76.6	68.6	96.6
F231-2 Sound Attenuated Level 1, Aluminium	Mounted	100% Standby	19.1	45.4	61.3	72.4	83.3	83.4	84.4	82.5	79.3	76.0	66.7	90.1
F217-2 Sound Attenuated Level 2, Aluminium	Mounted	100% Standby	17.2	47.5	61.8	71.6	78.4	79.6	82.1	81.0	78.0	73.3	64.9	87.4

A-weighted Sound Pressure Level @ Operator Location, dB(A)

See notes 1, 5 and 7-15 listed below

Configuration	Exhaust	Applied Load	Octave Band Center Frequency (Hz)											Overall Sound Pressure Level
			16	31.5	63	125	250	500	1000	2000	4000	8000	16000	
Standard - Unhoused	Infinite Exhaust	100% Standby	13.4	33.8	50.6	70.1	75.8	81.4	86.5	88.0	83.2	86.6	75.0	100.2
F216-2 Weather Protective Aluminium	Mounted	100% Standby	19.7	46.5	63.3	71.9	83.8	87.1	87.4	90.0	85.5	79.2	68.8	94.4
F231-2 Sound Attenuated Level 1, Aluminium	Mounted	100% Standby	18.3	45.8	61.6	71.1	78.9	78.5	78.0	75.4	72.5	71.9	60.0	84.7
F217-2 Sound Attenuated Level 2, Aluminium	Mounted	100% Standby	14.4	42.3	61.1	72.7	75.8	75.0	74.4	74.2	71.6	70.4	62.1	82.3



Sound Data

C200N6B

QSL8.9G-G3 60Hz Natural Gas

A-weighted Sound Power Level, dB(A)

See notes 1, 3 and 6-14 listed below

Configuration	Exhaust	Applied Load	Octave Band Center Frequency (Hz)											Overall Sound Power Level
			16	31.5	63	125	250	500	1000	2000	4000	8000	16000	
Standard - Unhoused	Infinite Exhaust	100% Standby	28.3	51.0	66.0	83.6	93.4	97.8	103.1	103.3	99.4	101.2	90.8	116.3
F216-2 Weather Protective Aluminium	Mounted	100% Standby	41.0	63.4	86.3	92.9	105.3	106.0	107.6	109.2	106.2	100.1	91.1	114.3
F231-2 Sound Attenuated Level 1, Aluminium	Mounted	100% Standby	37.3	63.6	79.4	90.6	101.5	101.6	102.5	100.6	97.5	94.1	84.8	108.3
F217-2 Sound Attenuated Level 2, Aluminium	Mounted	100% Standby	35.7	66.0	80.3	90.1	96.8	98.0	100.6	99.5	96.5	91.7	83.3	105.9

Exhaust Sound Power Level, dB(A)

See notes 4 and 6-14 listed below

Configuration	Applied Load	Octave Band Center Frequency (Hz)											Overall Sound Power Level
		16	31.5	63	125	250	500	1000	2000	4000	8000	16000	
Open Exhaust (No Muffler)	100% Standby	21.0	50.2	74.9	79.1	98.2	103.3	107.2	110.5	112.4	106.4	93	121.2

Global Notes:

1. Sound pressure levels at 1 meter are measured per the requirements of ISO 3744, ISO 8528-10, and European Communities Directive 2000/14/EC as applicable. The microphone measurement locations are 1 meter from a reference parallelepiped just enclosing the generator set (enclosed or unenclosed).
2. Seven-meter measurement location 1 is 7 meters (23 feet) from the generator (alternator) end of the generator set, and the locations proceed counter-clockwise around the generator set at 45° angles at a height of 1.2 meters (48 inches) above the ground surface.
3. Sound Power Levels are calculated according to ISO 3744, ISO 8528-10, and or CE (European Union) requirements.
4. Exhaust Sound Levels are measured and calculated per ISO 6798, Annex A.
5. Reference Sound Pressure Level is 20 µPa.
6. Reference Sound Power Level is 1 pW (10⁻¹² Watt).
7. Sound data for remote-cooled generator sets are based on rated loads without cooling fan noise.
8. Sound data for the generator set with infinite exhaust do not include the exhaust noise contribution.
9. Published sound levels are measured at CE certified test site and are subject to instrumentation, measurement, installation and manufacturing variability.
10. Unhoused/Open configuration generator sets refers to generator sets with no sound enclosures of any kind.
11. Housed/Enclosed/Closed/Canopy configuration generator sets refer to generator sets that have noise reduction sound enclosures installed over the generator set and usually integrally attached to the skid base/base frame/fuel container base of the generator set.
12. Published sound levels meet the requirements India's Central Pollution Control Board (Ministry of Environment & Forests), vide GSR 371 (E), which states the A-weighted sound level at 1 meter from any diesel generator set up to a power output rating of 1000kVA shall not exceed 75dB(A)
13. For updated noise pollution information for India see website: <http://www.envfor.nic.in/legis/legis.html>
14. Sound levels must meet India's Ambient Air Noise Quality Standards detailed for Daytime/Night-time operation in Noise Pollution (Regulation and Control) Rules, 2000
15. Operator Location is near genset control panel and is at 1 meter distance from genset control panel and at 1.6 meter height.



Cooling System Data

C200N6B

QSJ8.9G-G3

High Ambient Air Temperature Radiator Cooling System											
	Fuel Type	Duty	Rating (kW)	Max cooling @ air flow static restriction, unhooded (inches water/mm water)					Housed in free air, no air discharge restriction		
				0.0/0.0	0.25/6.4	0.5/12.7	0.75/19.1	1.0/25.4	Weather (F216)	Sound Level 1 (F231)	Sound Level 2 (F217)
				Maximum allowable ambient temperature, degree C							
60 Hz	Natural Gas	Standby	200	55	52	50	N/A	N/A	47	45	45
		Airflow (m ³ /s) – Actual @ Fan									
				6.1	5.9	5.7	N/A	N/A	N/A	N/A	N/A

Notes:

1. Data shown are anticipated cooling performance for typical generator set.
2. Cooling data is based on 1000 ft (305 m) site test location.
3. Generator set power output may need to be reduced at high ambient conditions. Consult generator set data sheet for derate schedules.
4. Cooling performance may be reduced due to several factors including but not limited to: Incorrect installation, improper operation, fouling of the cooling system, and other site installation variables.



Exhaust Emission Data Sheet

C200N6B

60 Hz Spark Ignited Generator Set

EPA Emissions

Engine Information:

Model:	QSJ8.9G-G3	Bore:	4.49 in. (114 mm)
Type:	4 cycle, in-line, 6-cylinder	Stroke:	5.69 in. (145 mm)
Aspiration:	Turbocharged and Aftercooled	Displacement:	543 cu. in. (9 liters)
Compression Ratio:	8.5:1		
Emission Control Device:	Electronic Air/Fuel Ratio & Closed-Loop Breather System		

Natural Gas

	<u>1/4</u>	<u>1/2</u>	<u>3/4</u>	<u>Full</u>
<u>Performance Data</u>	<u>Standby</u>	<u>Standby</u>	<u>Standby</u>	<u>Standby</u>
BHP @ 1800 RPM (60 Hz)	86.6	156.3	228.2	310.0
Fuel Consumption (SCFH)	834	1442	1961	2599
Exhaust Gas Flow (CFM)	593	1028	1227	1400
Exhaust Gas Temperature (°F)	1167	1133	1107	1092
Air to Fuel Ratio	22.0	24.9	24.9	24.9
 <u>Exhaust Emission Data</u>				
HC (Total Unburned Hydrocarbons)*	0.84	1.79	1.16	0.58
NOx (Oxides of Nitrogen as NO ₂)	2.20	0.46	0.80	1.53
CO (Carbon Monoxide)	1.67	1.60	1.52	1.45
	All values above are cited: g/BHP-hr			
HC (Total Unburned Hydrocarbons)*	360	709	496	259
NOx (Oxides of Nitrogen as NO ₂)	284	55	103	204
CO (Carbon Monoxide)	353	313	320	317
	All values above are cited: ppmvd			

*HC includes NMHC, VOC, POC, and ROC constituents (Non-Methane HC, Volatile Organic Compounds, Precursor Organic Compounds and Reactive Organic Compounds).



Exhaust Emission Data Sheet

C200N6B

60 Hz Spark Ignited Generator Set

EPA Emissions

Test Conditions

Test Conditions apply to both Natural Gas and Propane

Data is representative of steady-state engine speed (± 25 RPM) with full load ($\pm 2\%$). Pressures, temperatures, and emission rates were stabilized.

Fuel Specification:	Natural Gas: Dry gas received from Supplier (1000 BTU/SCF)
Fuel Inlet Temperature:	60 ± 9 °F at flow transmitter
Fuel Pressure:	$14.73\text{PSIA} \pm 0.5$ PSIA at Flow Transmitter
Air Inlet Temperature:	77 ± 9 °F
Barometric Pressure:	22.92 ± 1 in. Hg
Humidity:	NOx measurement corrected to 75 grains H ₂ O/lb (10.7 g/kg) of dry air

The NOx, HC, CO and PM emission data tabulated here are representative of test data taken from a single engine under the test conditions shown above. These data are subjected to instrumentation and engine-to-engine variability. Field emission test data are not guaranteed to these levels. Actual field test results may vary due to test site conditions, installation, fuel specification, test procedures and instrumentation. Engine operation with excessive air intake or exhaust restriction beyond published maximum limits, or with improper maintenance, may result in elevated emission levels.



Prototype Test Support (PTS) 60 Hz test summary



<u>Generator set models</u>	<u>Representative prototype</u>
C175N6B	Model: C200N6B
C200N6B	Engine: QSJ8.9G-G3
	Alternator: UCDI274K

The following summarizes prototype testing conducted on the designated representative prototype of the specified models. This testing is conducted to verify the complete generator set electrical and mechanical design integrity. Prototype testing is conducted only on generator sets not sold as new equipment.

Maximum surge power: 211.5 kW
The generator set was evaluated to determine the stated maximum surge power.

Maximum motor starting: N/A
The generator set was tested to simulate motor starting by applying the specified kVA load at low lagging power factor (0.4 or lower). With this load applied, the generator set recovered to a minimum of 90% rated voltage

Alternator temperature rise:
The highest rated temperature rise (120 °C) test result are reported as follows to verify that worst case temperature rises do not exceed allowable NEMA MG1 limits for class H insulation. Tests were conducted per IEEE 115, rise by resistance and embedded detector, with rated voltages. Only the highest temperatures are reported.

Torsional analysis and testing:
The generator set on UCDI274K was tested to verify that the design is not subjected to harmful torsional stresses. A spectrum analysis of the transducer output was conducted over the speed range of 1710 to 1890 RPM.

Cooling system: 50°C ambient
0.5 in H2O restriction

The cooling system was tested to determine ambient temperature and static restriction capabilities. The test was performed at full rated load elevated ambient temperature under static restriction conditions.

Durability:
The generator set was subjected to a 500 hour endurance test replicating field duty cycles operating at variable load up to the standby rating based in MIL-STD-705 to verify structural soundness and durability of the design.

Electrical and mechanical strength:
The generator set was tested to several single phase and three phase faults to verify that the generator can safely withstand the forces associated with short circuit conditions. The generator set was capable of producing full rated output at the conclusion of the testing.

Steady state performance:
The generator set was tested to verify steady state operating performance. It was within the specified maximum limits.

Voltage regulation:	± 1%
Random voltage variation:	± 1%
Frequency regulation:	Isochronous
Random frequency variation:	± 0.25%

Transient performance:
The generator set was tested with the listed alternator to verify single step loading capability as required by NFPA 110. Voltage and frequency response on load addition or rejection were evaluated. The following results were recorded at 0.8 power factor:

Full load acceptance:

Voltage dip:	36.8%
Recovery time:	4.7 seconds
Frequency dip:	19.7%
Recovery time:	8.4 seconds

Full load rejection:

Voltage rise:	18.7%
Recovery time:	2.1 seconds
Frequency rise:	20.5%
Recovery time:	3.3 seconds

All data based on 0.8 power factor:

Harmonic analysis:
(per MIL-STD-705B, Method 601.4)

Harmonic	<u>Line to Line</u>		<u>Line to Neutral</u>	
	<u>No load</u>	<u>Full load</u>	<u>No load</u>	<u>Full load</u>
	3	0.1	0.1	0.1
5	0.7	1.0	0.7	1.0
7	1.0	3.1	1.0	3.1
9	0.0	0.0	0.0	0.0
11	0.1	0.3	0.1	0.3
13	0.1	0.4	0.1	0.4
15	0.0	0.0	0.0	0.0

SECTION 3

Generator Accessories





Data Sheet

Circuit Breakers

Description

This Data sheet provides circuit breaker manufacturer part numbers and specifications. The Circuit breaker box description is the rating of that breaker box installation on a Cummins Generator. Please refer to the website of the circuit breaker manufacturer for breaker specific ratings and technical information.

Applicable Models

Engine	Models					
Kubota	C10D6	C15D6	C20D6			
QSJ2.4	C20N6	C25N6	C30N6	C30N6H	C36N6	C36N6H
	C40N6	C40N6H	C50N6H	C60N6H		
B3.3	C25D6	C30D6	C35D6	C40D6	C50D6	C60D6
QSJ5.9G	C45N6	C50N6	C60N6	C70N6	C80N6	C100N6
QSJ8.9G	C125N6	C150N6	C175N6B	C200N6B		
QSB5	DSFAC	DSFAD	DSFAE	C50D6C	C60D6C	C80D6C
	C100D6C	C125D6C				
QSB7	DSGAA	DSGAB	DSGAC	DSGAD	DSGAE	
		C125D6D	C150D6D	C175D6D	C200D6D	
QSL9	DSHAD	DQDAA	DQDAB	DQDAC		
QSM11	DQHAB					
QSX15	DFEJ	DFEK				

Instructions

1. Locate the circuit breaker feature code or part number and use the charts below to find the corresponding manufacturer circuit breaker catalog number.
2. Use the first letter of the circuit breaker catalog number to determine the "frame" of the breaker. If the first letter is an "N", use the second letter. Then follow the corresponding website link from the table below to find the breaker catalog number description.

Please refer to the catalog numbering systems page, which is given in the chart, to understand the nomenclature of the catalog number.

Frame	Catalog name*	Catalog number description page(s)
P	0612CT0101 http://www.schneider-electric.us/en/download/document/0612CT0101/	16-17
H, J, and L	0611CT1001 http://www.schneider-electric.us/en/download/document/0611CT1001/	8-9
Q	0734CT0201 http://www.schneider-electric.us/en/download/document/0734CT0201/	4

*The following link may also be used to search specifically by the breaker part number or for the catalog name listed above. <http://products.schneider-electric.us/technical-library/>

3. Search the catalog by using the first 3 letters of the breaker catalog number and the first 5 numbers to find information such as trip curves, accessories, and dimensional details regarding the circuit breaker.

*If the catalog number starts with "N", skip the N and begin your search with the second letter.

*If the first 3 letters are "PJP," the search will not work. You will need to start with just "PJ" and use the description pages to obtain the information you are looking for on the "PJP."

Example

After finding your circuit breaker catalog number to be "PJL36120U33EACUKMOYB," navigate to the P-frame catalog by using the link provided.

Look at pages 16-17 of the pdf catalog to find the nomenclature of the breaker.

Search the P-frame spec sheet using the search "PJL36120."

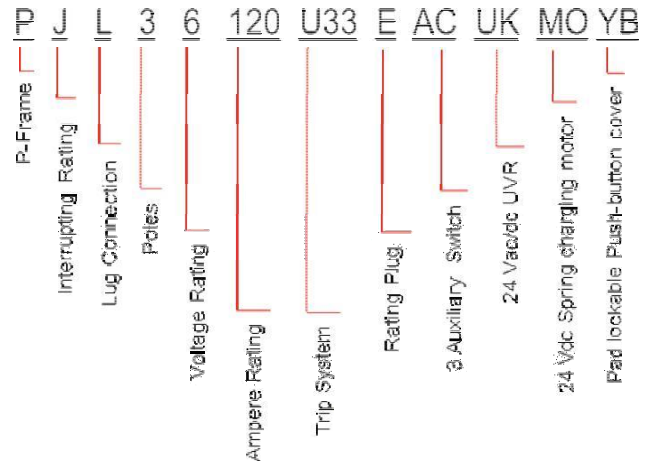

Feature Code	Breaker Box Description	Cummins Part #	Manufacturer	Breaker Catalog Number	Trip Unit	Plug Type
KX28-2	CB,Loc B,70A-250A,3P,LSI,600VAC,100%,UL	A050J727	Schneider Electric	JDL36250CU33X	MicroLogic 3.2S	N/A
KX29-2	CB,Loc C,70A-250A,3P,LSI,600VAC,100%,UL	A050J727	Schneider Electric	JDL36250CU33X	MicroLogic 3.2S	N/A
KX30-2	CB,Loc A,125A-400A,3P,LSI,600VAC,100%,UL	A051D115	Schneider Electric	LGL36400CU33X	MicroLogic 3.3S	N/A
KX31-2	CB,Loc B,125A-400A,3P,LSI,600VAC,100%,UL	A051D115	Schneider Electric	LGL36400CU33X	MicroLogic 3.3S	N/A
KX32-2	CB,Loc A,200A-600A,3P,LSI,600VAC,80%,UL	A044T468	Schneider Electric	NLGL36600U33X-600A	MicroLogic 3.3S	N/A
KX33-2	CB,Loc B,200A-600A,3P,LSI,600VAC,80%,UL	A044T468	Schneider Electric	NLGL36600U33X-600A	MicroLogic 3.3S	N/A
KX34-2	CB,Loc C,15A,3P,600VAC,80%,UL	A043L506	Schneider Electric	HDL36015	Thermal Magnetic	N/A
KX35-2	CB,Loc C,20A,3P,600VAC,80%,UL	A043L480	Schneider Electric	HDL36020	Thermal Magnetic	N/A
KX36-2	CB,Loc C,25A,3P,600VAC,80%,UL	A043L508	Schneider Electric	HDL36025	Thermal Magnetic	N/A
KX37-2	CB,LoC C,30A,3P,600VAC,80%,UL	A043L475	Schneider Electric	HDL36030	Thermal Magnetic	N/A
KX38-2	CB,Loc C,40A,3P,600VAC,80%,UL	A043L464	Schneider Electric	HDL36040	Thermal Magnetic	N/A
KX39-2	CB,Loc C,50A,3P,600VAC,80%,UL	A043L461	Schneider Electric	HDL36050	Thermal Magnetic	N/A
KX40-2	CB,Loc C,60A,3P,600VAC,80%,UL	A043L459	Schneider Electric	HDL36060	Thermal Magnetic	N/A
KX41-2	CB,Loc C,70A,3P,600VAC,80%,UL	A043L451	Schneider Electric	HDL36070	Thermal Magnetic	N/A
KX42-2	CB,Loc C,80A,3P,600VAC,80%,UL	A043L012	Schneider Electric	HDL36080	Thermal Magnetic	N/A

Product data sheet

Specifications

SQUARE D

Green Premium™



Circuit breaker, PowerPacT L, unit mount, Micrologic 3.3S, 400A, 3 pole, 18kA, 600VAC,

LGL36400CU33X

Main

Range	PowerPact
Product name	PowerPact L
Device short name	L-Frame
Product or Component Type	Circuit breaker
Device Application	Distribution

Complementary

Line Rated Current	400 A
Number of Poles	3P
Control Type	Toggle
Breaking capacity code	G
Breaking capacity	65 kA 240 V AC 50/60 Hz UL 489 35 kA 480 V AC 50/60 Hz UL 489 18 kA 600 V AC 50/60 Hz UL 489 18 kA 250 V DC UL 489 20 kA 500 V DC UL 489
[Ue] rated operational voltage	600 V AC 50/60 Hz IEC 60947-3
Network Frequency	50/60 Hz
[Ics] rated service breaking capacity	65 kA 220/240 V AC 50/60 Hz IEC 60947-2 35 kA 380/440/415 V AC 50/60 Hz IEC 60947-2 18 kA 500/525 V AC 50/60 Hz IEC 60947-2 20 kA 250 V DC IEC 60947-2 20 kA 500 V DC IEC 60947-2
[Uimp] rated impulse withstand voltage	8 kV IEC 60947-2
Trip unit technology	Electronic, standard, Micrologic 3.3 S, LSI
[Ui] rated insulation voltage	750 V IEC 60947-2
Trip unit name	Micrologic 3.3 S
Suitability for isolation	Yes IEC 60947-2
Utilisation category	Category A
AWG gauge	Please see CB outline drawing for lug and termination details
Local signalling	Ready 1 LED green) Alarm 1 LED 90 % Ir orange)

Alarm LED 105 % Ir red)
Switched off (OFF) 1 trip indicator green)

Mounting mode	Unit mount lug)
Mounting Support	Lug
Electrical connection	Lugs line Lugs load
Terminal identifier	Please see CB outline drawing for lug and termination details
Long time pick-up adjustment range	0.25...1 x In
Tightening torque	442.54 lbf.in (50 N.m) 0.11...0.37 in ² (70...240 mm ²) (AWG 2/0...500 kcmil)
Number of slots	2 auxiliary switch OF plug-in) 1 alarm switch SD plug-in) 1 overcurrent trip switch SDE plug-in) 1 voltage release MN or MX plug-in)
Power wire stripping length	1.22 in (31 mm) 2.40 in (61 mm)
Color	Black
Height	13.39 in (340 mm)
Width	5.51 in (140 mm)
Depth	4.33 in (110 mm)
Net Weight	13.67 lb(US) (6.2 kg)
Communication interface	Modbus Ethernet

Environment

Standards	UL CSA NEMA NOM-003-SCFI-2000 IEC 60947-2
Product certifications	UL CSA NOM
IP degree of protection	Front cover IP40
Pollution degree	3 IEC 60947-1
Ambient Air Temperature for Operation	28...158 °F (-2...70 °C)
Ambient Air Temperature for Storage	-58...185 °F (-50...85 °C)
Operating altitude	< 6561.68 ft (2000 m) without derating 5000 m with derating

Ordering and shipping details

Category	01116-L ELEC TRIP UNIT MOUNT BREAKER/SW
Discount Schedule	DE2
GTIN	785901486831
Nbr. of units in pkg.	1
Package weight(Lbs)	15.00 lb(US) (6.804 kg)
Returnability	Yes
Country of origin	US

Packing Units

Unit Type of Package 1	PCE
-------------------------------	-----

Package 1 Height	8.75 in (22.225 cm)
Package 1 width	10.75 in (27.305 cm)
Package 1 Length	19.50 in (49.53 cm)

Offer Sustainability

Sustainable offer status	Green Premium product
California proposition 65	WARNING: This product can expose you to chemicals including: DINP, which is known to the State of California to cause cancer, and DIDP, which is known to the State of California to cause birth defects or other reproductive harm. For more information go to www.P65Warnings.ca.gov
REACH Regulation	REACH Declaration
EU RoHS Directive	Compliant EU RoHS Declaration
Mercury free	Yes
RoHS exemption information	Yes
China RoHS Regulation	China RoHS declaration Product out of China RoHS scope. Substance declaration for your information.
Environmental Disclosure	Product Environmental Profile
Circularity Profile	End of Life Information
PVC free	Yes

Dimensions

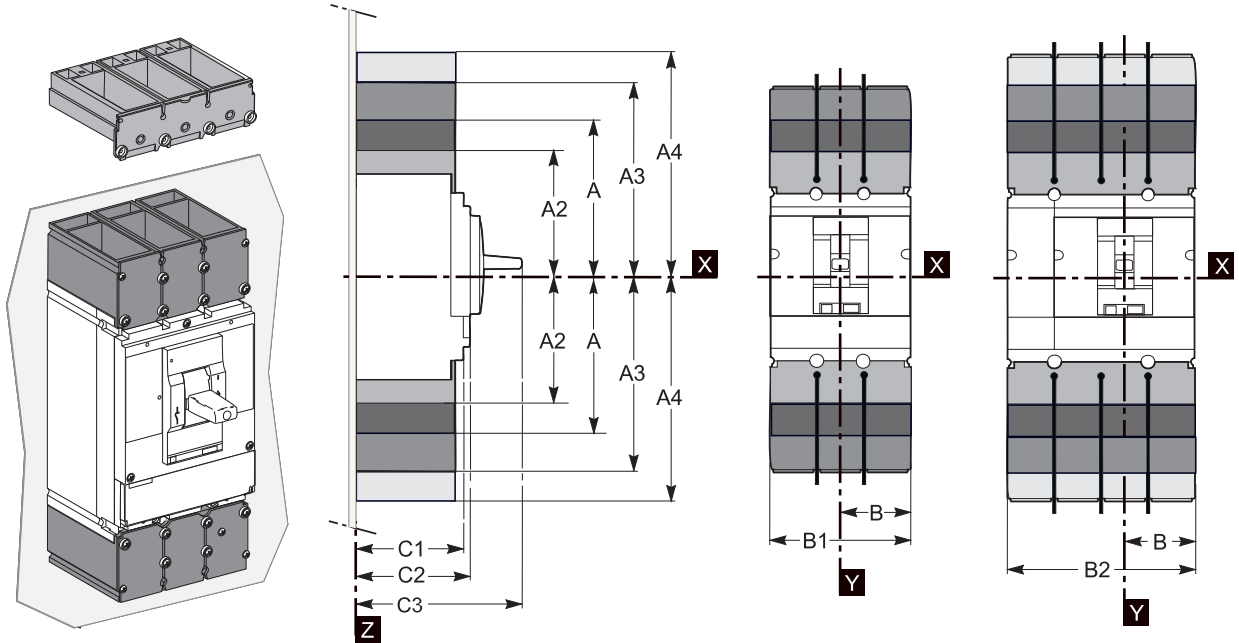

A2 = Short Lug Pack
 AL400L61K3
 CU400L61K3
 AL600LF52K3
 CU600LF5283

A = Medium Lug Pack
 AL400L61K4
 CU400L61K4
 AL600LS52K3
 AL600LS52K4
 CU600LS52K3
 CU600LS52K4

A3 = Long Lug Pack
 Compression Lug Kits
 A4 = 500 Vdc Lug Pack

L-Frame

	A	A2	A3	A4	B	B1	B2	C1	C2	C3
inch	6.69	5.65	7.87	9.53	2.76	5.51	7.28	3.76	4.33	6.61
mm	170	143.5	200	242	70	140	185	105	110	168

All dimensions are approximate.
 Also see CAD, technical drawings, and technical documentation.

PowerPact™ H-, J-, and L-Frame Circuit Breakers Trip Units

Micrologic™ 3 Trip Units

Micrologic 3 trip units can be used on PowerPact H-, J-, and L-Frame circuit breakers with performance levels D/G/J/L.

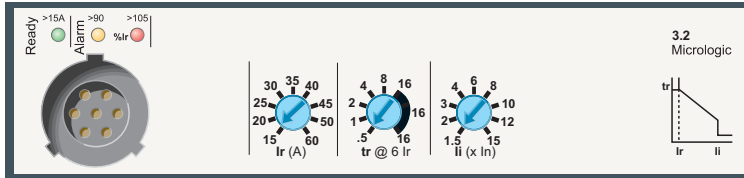

They provide:

- standard protection of distribution cables
- indication of:
 - overloads (using LEDs)
 - overload tripping (using the SDx relay module).

Circuit breakers equipped with Micrologic 3 trip units can be used to protect distribution systems supplied by transformers.

Protection

Settings are made using the adjustment rotary switches.

Overloads: Long time protection (I_r)

Inverse time protection against overloads with an adjustable current pick-up I_r set using a rotary switch and an adjustable time delay t_r .

Neutral protection

- On 3-pole L-frame circuit breakers, neutral protection is not possible.
- On four-pole L-frame circuit breakers, neutral protection may be set using a three-position switch:
 - switch position 4P 3D: neutral unprotected
 - switch position 4P 3D + N/2: neutral protection at half the value of the phase pick-up, ($0.5 \times I_r$)
 - switch position 4P 4D: neutral fully protected at I_r

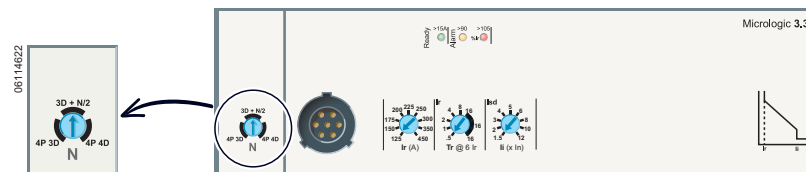

Indicators

Front indicators

- The green “Ready” LED blinks slowly when the electronic trip unit is ready to provide protection. It indicates the trip unit is operating correctly.
- Orange overload pre-alarm LED: steady on when $I > 90\% I_r$
- Red overload LED: steady on when $I > 105\% I_r$

Remote indicators

An overload trip signal can be remotely checked by installing an SDx relay module inside the circuit breaker. This module receives the signal from the Micrologic electronic trip unit through an optical link and makes it available on the terminal block. The signal is cleared when the circuit breaker is reclosed. See page 94.

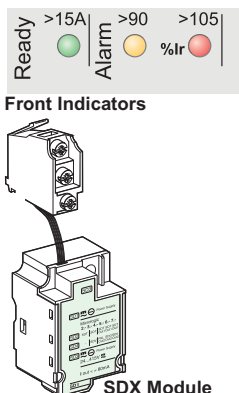

PowerPact™ H-, J-, and L-Frame Circuit Breakers Trip Units

Table 50: Micrologic™ 3 Trip Unit

Ratings	I_n at 104°F (40°C) ¹		60 A	100 A	150 A	250 A	400 A	600 A
Circuit Breaker	H-frame		X	X	X			
	J-frame					X		
	L-frame					X	X	X

Micrologic 3.2 / 3.3 trip units

L Long-time protection

	I_r		Value depending on sensor rating (I_n) and setting on rotary switch									
	Pick-Up (A) Tripping between 1.05 and 1.20 I_r	$I_n = 60$ A	$I_r =$	15	20	25	30	35	40	45	50	60
$I_n = 100$ A		$I_r =$	35	40	45	50	60	70	80	90	100	
$I_n = 150$ A		$I_r =$	50	60	70	80	90	100	110	125	150	
$I_n = 250$ A		$I_r =$	70	80	100	125	150	175	200	225	250	
$I_n = 400$ A		$I_r =$	125	150	175	200	225	250	300	350	400	
$I_n = 600$ A		$I_r =$	200	225	250	300	350	400	450	500	600	
Time Delay (s) Accuracy 0 to -20%	t_r		0.5	1	2	4	8	16				
	$1.5 \times I_r$		15	25	50	100	200	400				
	$6 \times I_r$		0.5	1	2	4	8	16				
		$7.2 \times I_r$	0.35	0.7	1.4	2.8	5.5	11				
Thermal memory			20 minutes before and after tripping									

I Instantaneous

Pick-up (A) accuracy ± 15%	$I_i \times$	60 A	1.5	2	3	4	6	8	10	12	15
		100 A	1.5	2	3	4	6	8	10	12	15
		150 A	1.5	2	3	4	6	8	10	12	15
		250 A	1.5	2	3	4	5	6	8	10	12
		400 A	1.5	2	3	4	5	6	8	10	12
		600 A	1.5	2	3	4	5	6	8	10	11
Non-tripping time Maximum break time		10 ms 50 ms for $I > 1.5 I_i$									

Micrologic 3.2S / 3.3S trip units

L Long-time protection

	I_r		Value depending on sensor rating (I_n) and setting on rotary switch									
	Pick-Up (A) Tripping between 1.05 and 1.20 I_r	$I_n = 60$ A	$I_r =$	15	20	25	30	35	40	45	50	60
$I_n = 100$ A		$I_r =$	35	40	45	50	60	70	80	90	100	
$I_n = 150$ A		$I_r =$	50	60	70	80	90	100	110	125	150	
$I_n = 250$ A		$I_r =$	70	80	100	125	150	175	200	225	250	
$I_n = 400$ A		$I_r =$	125	150	175	200	225	250	300	350	400	
$I_n = 600$ A		$I_r =$	200	225	250	300	350	400	450	500	600	
Time Delay (s) Accuracy 0 to -20%	t_r		non-adjustable									
	$1.5 \times I_r$		400									
	$6 \times I_r$		16									
		$7.2 \times I_r$	11									
Thermal memory			20 minutes before and after tripping									

S Short-time protection

Pick-up (A) accuracy ± 10%	$I_{sd} - I_r \times \dots$		1.5	2	3	4	5	6	7	8	10
Time delay (ms)	t_{sd}		non-adjustable								
	Non-tripping time Maximum break time		20 80								

I Instantaneous

Pick-up (A) accuracy ± 15%	$I_i \times I_n$		1.5	2	3	4	6	8	10	12	15
Non-tripping time Maximum break time		10 ms 50 ms for $I > 1.5 I_i$									

¹ If the trip units are used in high-temperature environments, the Micrologic trip unit setting must take into account the thermal limitations of the circuit breaker. See the temperature derating information on page 126.

CURRENT IN MULTIPLES OF I_r

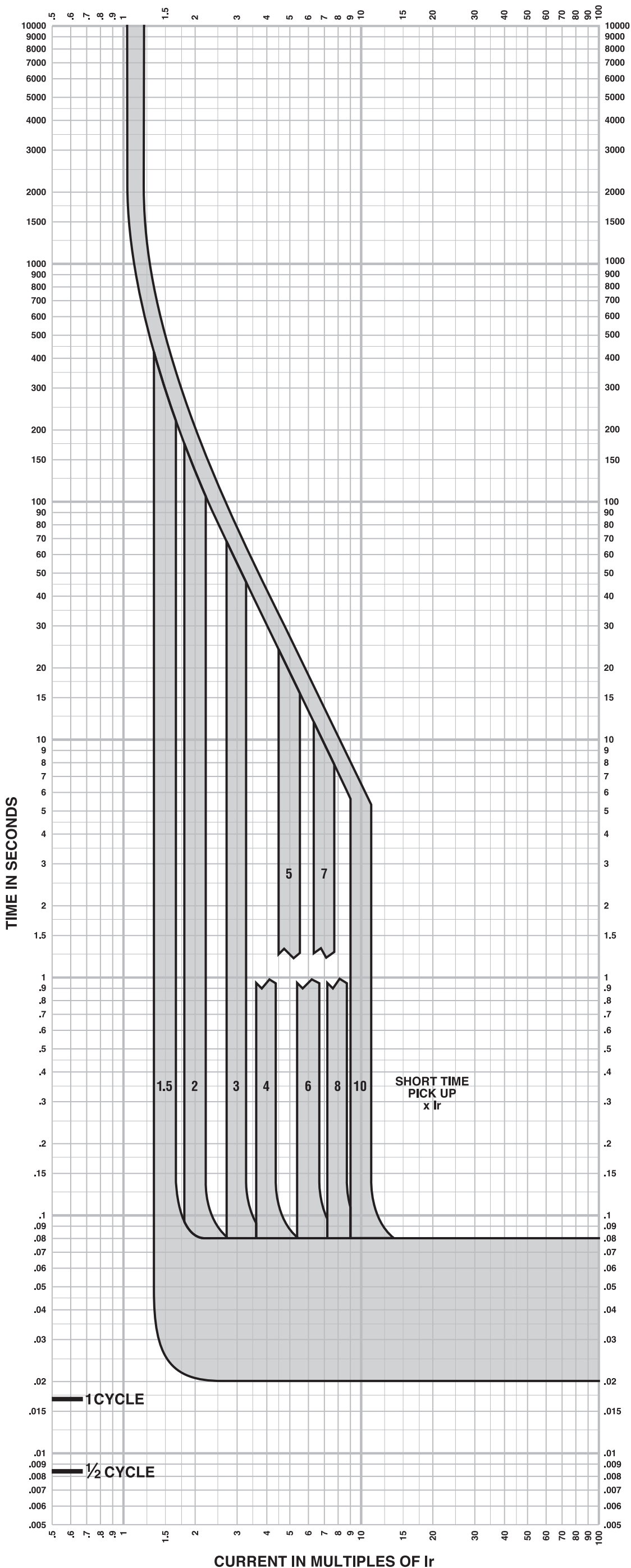

MICROLOGIC™ ELECTRONIC TRIP UNITS
Micrologic™ 3.3S Long Time/
Short Time Trip Curve
250A, 400A L-Frame

The time-current curve information is to be used for application and coordination purposes only.

Notes:

1. There is a thermal-imaging effect that can act to shorten the long-time delay. The thermal imaging effect comes into play if a current above the long-time delay pickup value exists for a time and then is cleared by the tripping of a downstream device or the circuit breaker itself. A subsequent overload will cause the circuit breaker to trip in a shorter time than normal. The amount of time delay reduction is inverse to the amount of time that has elapsed since the previous overload. Approximately 20 minutes is required between overloads to completely reset thermal-imaging.
2. Total clearing times shown include the response times of the trip unit, the circuit breaker opening, and the extinction of the current.

Curves apply from -35°C to $+70^{\circ}\text{C}$ (-31°F to $+158^{\circ}\text{F}$) ambient temperature.

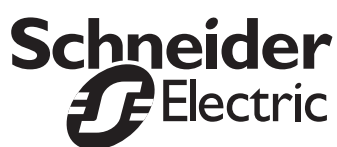

MULTIPLES OF I_n

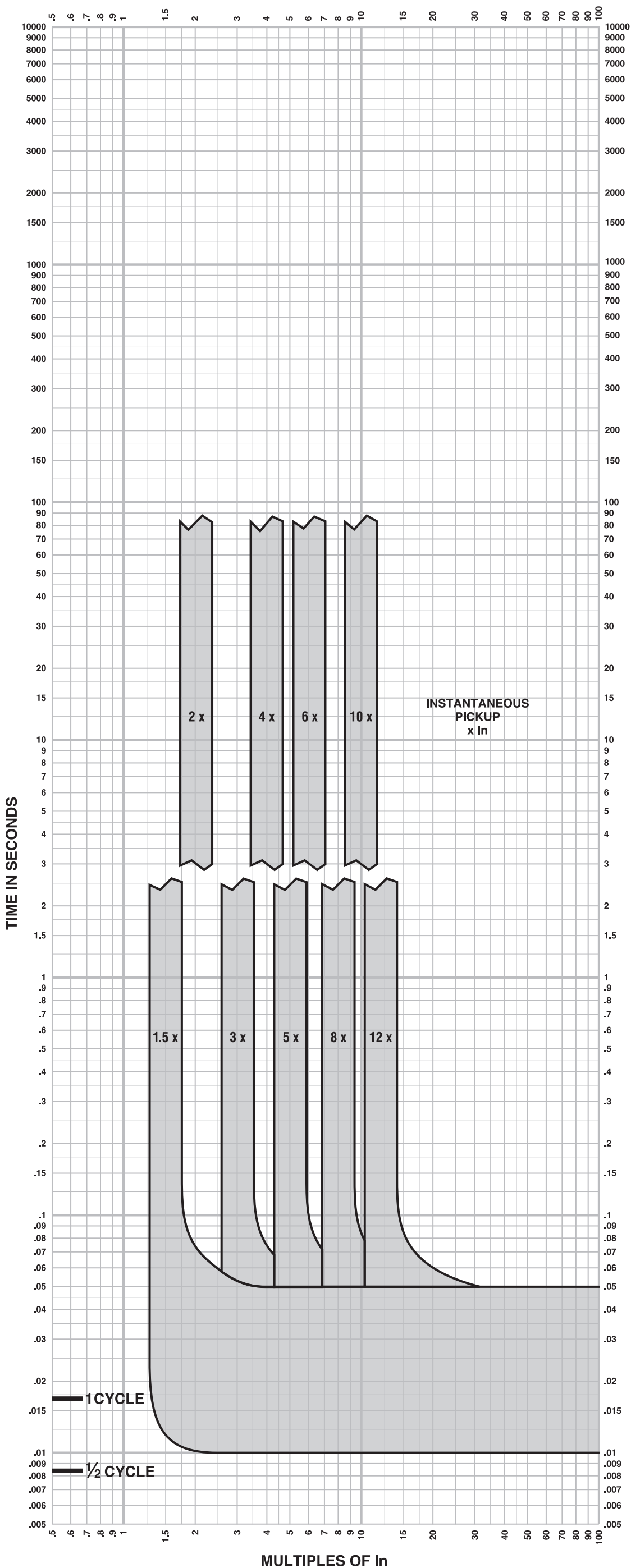

MICROLOGIC™ ELECTRONIC TRIP UNITS
Micrologic™ 3.3/3.3S/5.3A or E/6.3A or E
Instantaneous Trip Curve
400A L-Frame

The time-current curve information is to be used for application and coordination purposes only.

Notes:

1. There is a thermal-imaging effect that can act to shorten the long-time delay. The thermal imaging effect comes into play if a current above the long-time delay pickup value exists for a time and then is cleared by the tripping of a downstream device or the circuit breaker itself. A subsequent overload will cause the circuit breaker to trip in a shorter time than normal. The amount of time delay reduction is inverse to the amount of time that has elapsed since the previous overload. Approximately 20 minutes is required between overloads to completely reset thermal-imaging.
 2. Total clearing times shown include the response times of the trip unit, the circuit breaker opening, and the extinction of the current.
 3. I_n = Maximum dial setting of I_r .
 400A L-Frame: I_n = 400A = Max I_r setting
- Curves apply from -35°C to $+70^{\circ}\text{C}$ (-31°F to $+158^{\circ}\text{F}$) ambient temperature.





Gas Fuel Line Accessories

Flexible Hose (Braided)

For use with natural gas or LPG vapor. Part numbers are bulk hose. Specify length required. (UL Listed)

Part Number	Inside Diameter
503-0633	1/2"
503-1103	1"

LPG Liquid Fuel Line

Part Number

UL 536 Rated	Fitting Size	Length
501-0681*	1/4" or 3/4"	36"

*This hose is to be used on LP liquid sets only, and comes with male 3/4" NPT swivel on both ends plus two adapters to convert from 3/4" NPT to 1/4" NPT male.

Flexible Natural Gas or Water Lines

Used for city water-cooled installations requiring flexible lines between the engine and water supply, or used as natural gas/LP vapor fuel supply lines made on flexible seamless hose with a thin braided bronze wire cover. Male pipe thread fittings are the same size at each end. Kit also includes fittings.

Part Number	Length	Fitting Size
541-0832	20.5"	1/2"
541-0833	24.0"	3/4"
501-0681	36.0"	3/4"
541-0834	27.0"	1"
541-0835	31.5"	1-1/4"
501-0776-05	40.5"	1-1/2"
503-2121	30.0"	2"

LPG Regulators

Gas pressure regulators with an internal relief valve. Not for use with LPG liquid.

Part Number	Inlet Pressure PSIG (ft ³ /hr)										NPT Pipe Size		Outlet Pressure	Orifice Size
	1/2	1	2	5	10	15	20	25	200	250	In	Out		
0148-0033										190	1/4"	1/2"	6 oz/in ²	1"
0148-0343	-	450	650	1000	1100	1200	1500	1500			1-1/4"	1-1/4"	5 to 15" H2O	
0148-0363	1600	2500	3500	5300	7750	7750	7750	7750			1-1/2"	1-1/2"	8.5 to 18" H2O	
0148-0597											3/4"	3/4"	6 oz/in ²	1/4"
0148-0637											3/4"	3/4"	3-1/2" to 5" H2O	
0148-0948									550		1/2"	3/4"	3-1/2" to 5" H2O	
0148-1202											1"	1"	6 oz/in ²	9/64"
0148-1231											3/4"	3/4"	6 oz/in ²	1/2"

Note: Part number 0148-0597 natural gas regulator can be converted to a 0148-0637 LPG vapor regulator by removing spring (0148-0952) and mounting with spring housing down.

SECTION 4

Generator Drawings



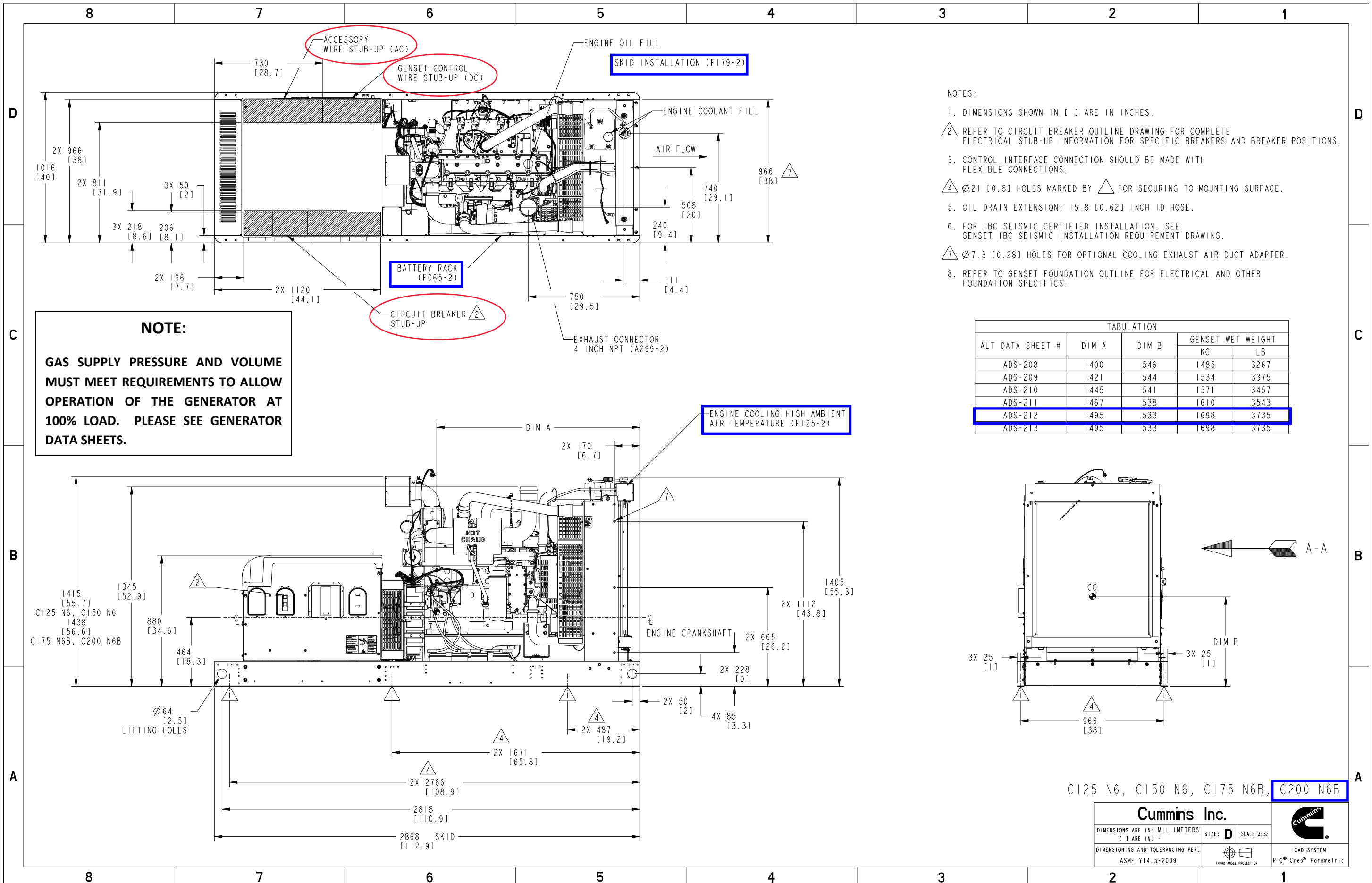

Document Generated: 17AUG2022 19:56 GMT

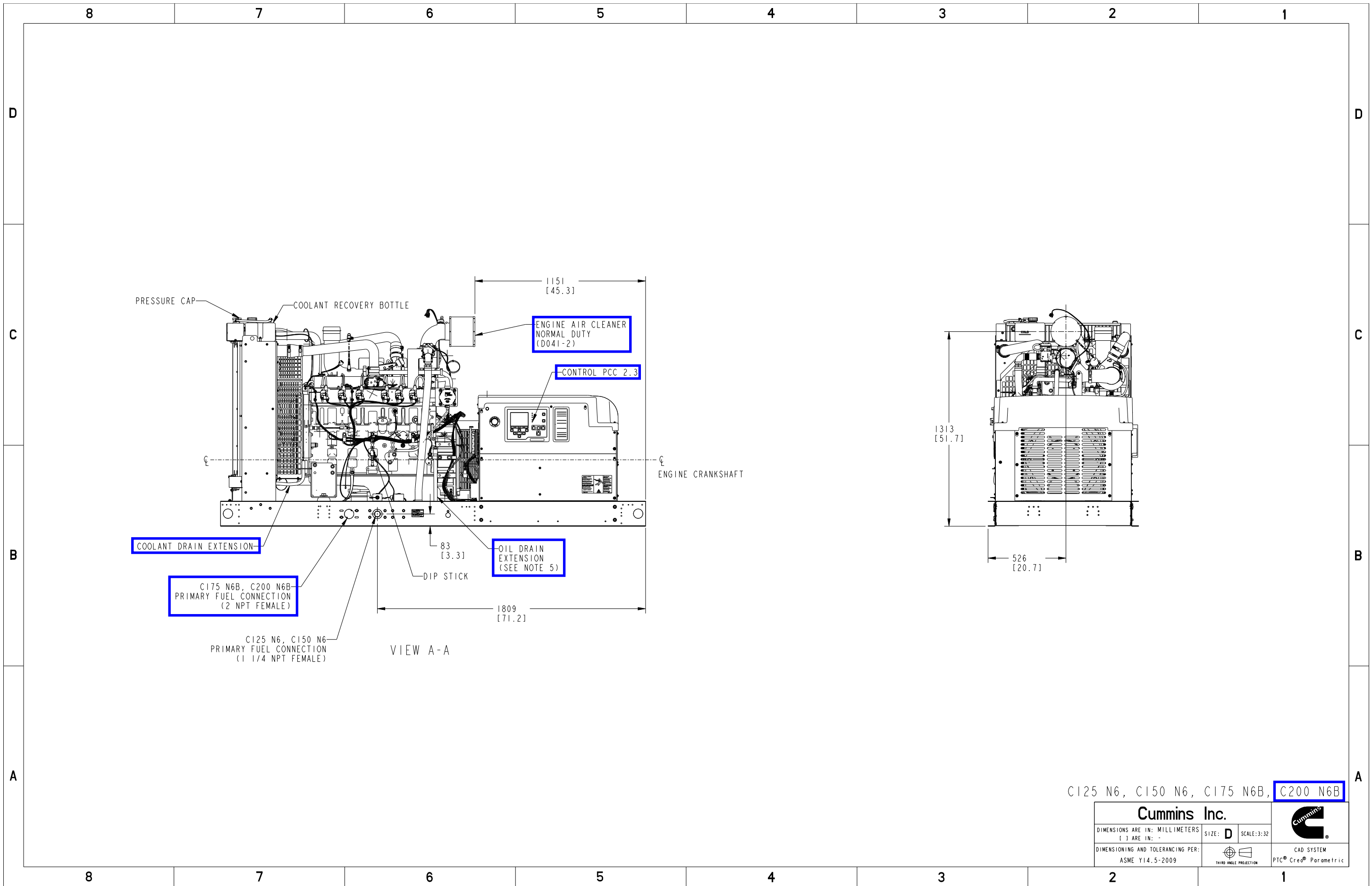

Document Generated: 17AUG2022 19:56 GMT

Cummins Data Classification:
Cummins Confidential

This document (and the information shown thereon) is **Confidential and Proprietary** and shall not be disclosed to others in hard copy or electronic form, reproduced by any means, or used for any purpose without written consent of Cummins Inc.

Part Number: **A055J588** Part Revision: **D**
 Part Name: **OUTLINE,GENSET**
 Drawing Category: **Detail** State: **Released** Sheet 2 of 3

REL NO	REV NO	REVISION	DWN	CKD	APVD	DATE
ECO-164828	A	1	Y	NK	A.CHINTHALURI	30SEP16

NOTES:

- DIM [] IN INCHES
- WITH THIS HOUSING INSTALLED ON AN OPEN GENERATOR SET, THE TOTAL WEIGHT WILL INCREASE BY 196 KG (432 LBS). THIS INCLUDES THE MUFFLER.
- THE CENTER OF GRAVITY OF THE GENERATOR SET WHEN EQUIPPED WITH THIS HOUSING SHIFTS APPROXIMATELY 63MM (2.48 INCH) TOWARDS THE AIR DISCHARGE END OF THE HOUSING AND 36MM (1.42 INCH) HIGHER FROM THE GROUND, COMPARED TO THE EQUIVALENT NON-HOUSED PRODUCT WITH THE F179 SKID. SEE HOUSING READY SKID BASE OUTLINE DRAWING FOR CG LOCATION OF NON HOUSED PRODUCT.

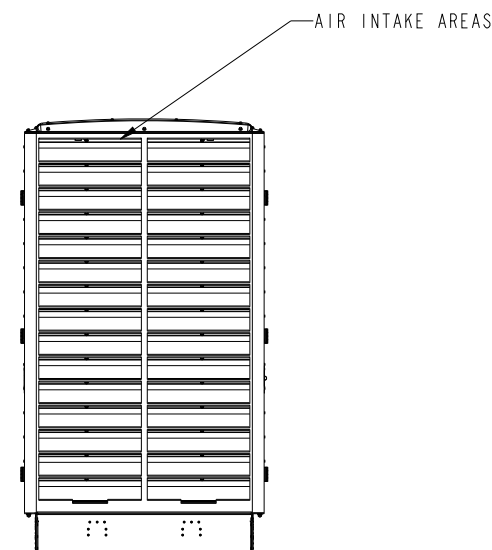

AIR INTAKE VIEW

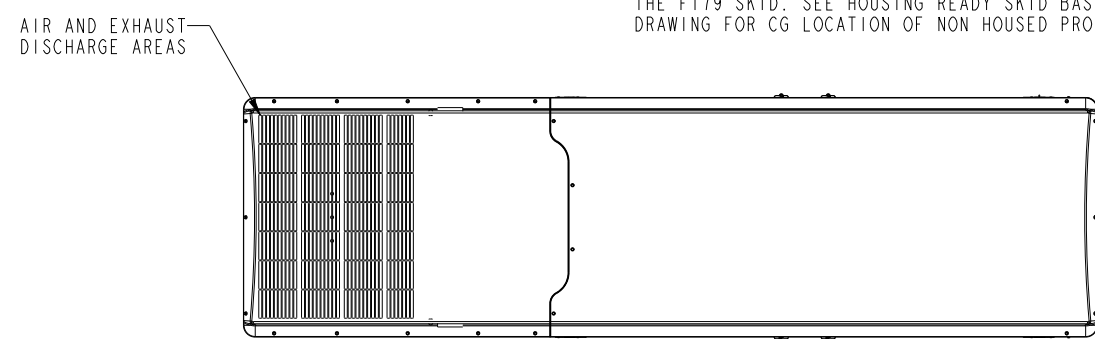

TOP VIEW

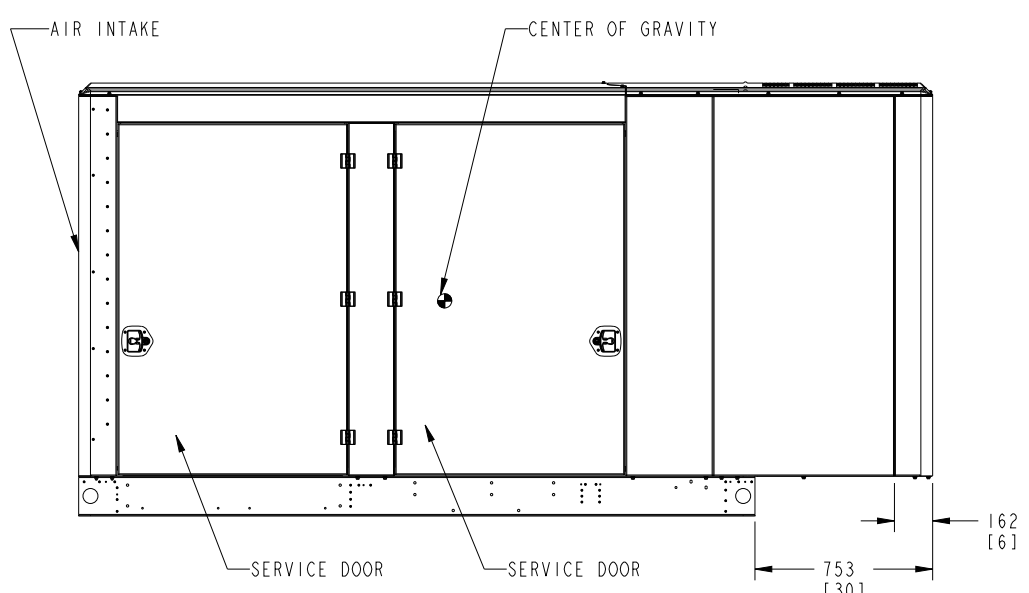

RIGHT SIDE VIEW

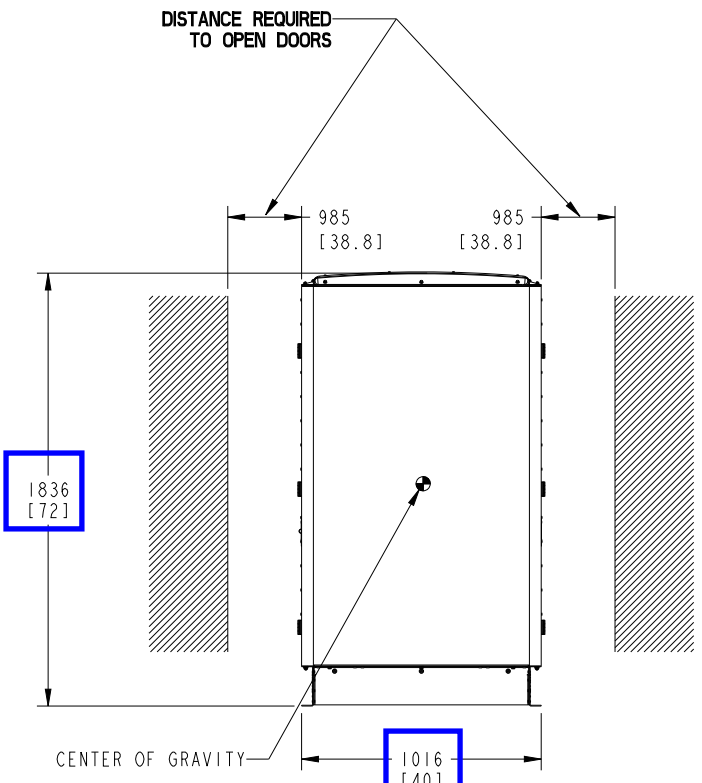

AIR OUTLET VIEW

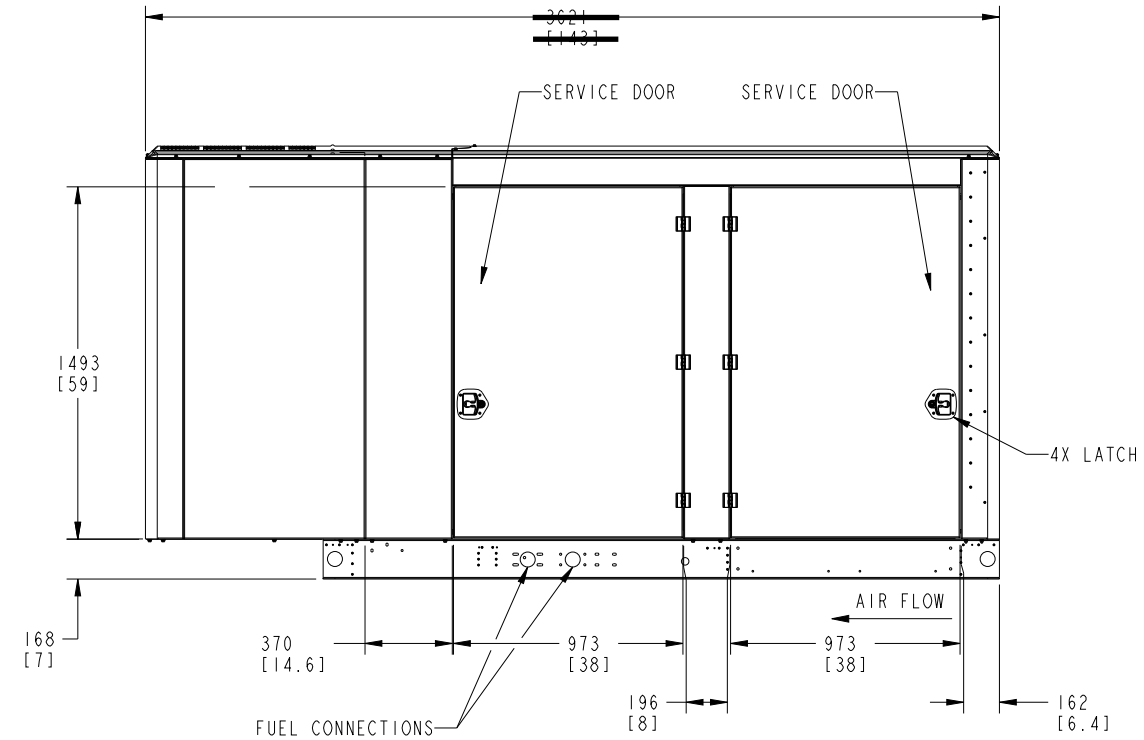

LEFT SIDE VIEW

F231-2 ENCLOSURE CONFIGURATION

UNLESS OTHERWISE SPECIFIED, ALL DIMENSIONS ARE IN MILLIMETERS		SHW TO: A051P365	DWN: Y_NICHT		CUMMINS POWER GENERATION
DO NOT SCALE PRINT		CKD: N_KASIBHOTLA	APVD: A.CHINTHALURI		OUTLINE, ENCLOSURE
DIM	TOLERANCE	DATE: 20SEP16		SITE CODE	
ANG TOL	SCALE	FIRST USED ON: ARROW		PGF	
± 1.0°	1/15	FOR INTERPRETATION OF DIMENSIONING AND TOLERANCING, SEE ASME Y14.5-2009		SIZE: D	CAD SHEET: 1 OF 2
				PGF	A055V240

REL NO	REV	NO	REVISION	DRN	CKD	APVD	DATE
ECO-164828	A	1	PRODUCTION_RELEASE	Y	N	A,CHINTHALURI	30SEP16

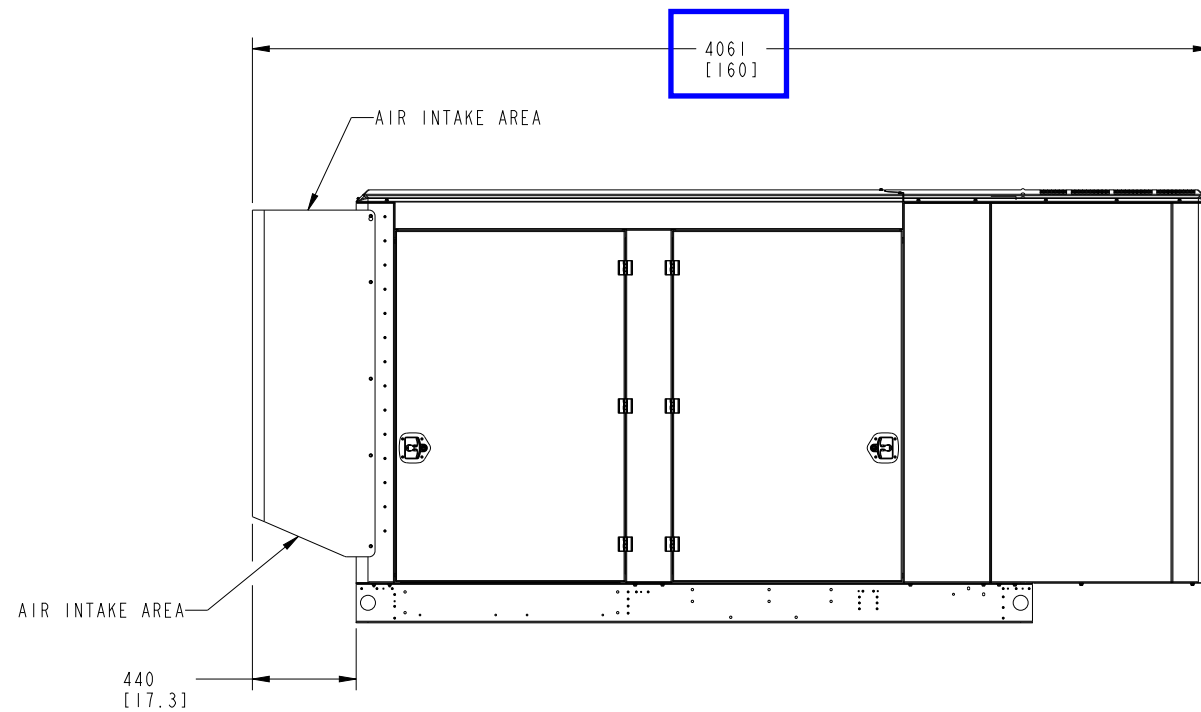
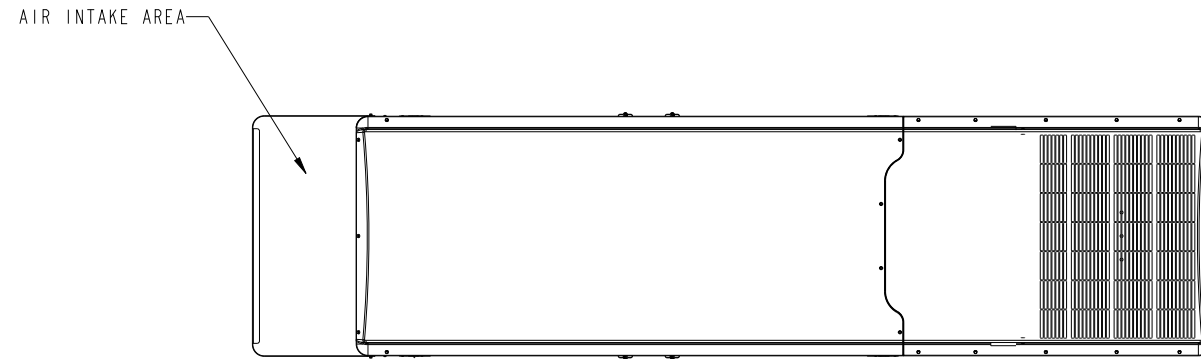

F217-2 ENCLOSURE CONFIGURATION
REFER TO PAGE 1 (F231-2 ENCLOSURE) FOR
OTHER F217-2 ENCLOSURE DIMENSIONS

UNLESS OTHERWISE SPECIFIED, ALL DIMENSIONS ARE IN MILLIMETERS				SHW TO	DWN	CUMMINS POWER GENERATION	
DO NOT SCALE PRINT				A051P365	Y_NICHT	OUTLINE, ENCLOSURE	
DIM	TOL	TOLERANCE		DATE	APVD	SITE CODE	DATE
X ± 1	0.00-4.99	+0.15/-0.08		20SEP16	A_CHINTHALURI		
.X ± 0.8	5.00-9.99	+0.20/-0.10					
.XX ± 0.38	10.00-17.49	+0.25/-0.13					
	17.50-24.99	+0.30/-0.13					
ANG TOL	SCALE	THIS DOCUMENT (AND THE INFORMATION SHOWN THEREON) IS CONFIDENTIAL AND PROPRIETARY AND SHALL NOT BE DISCLOSED TO OTHERS IN HARD COPY OR ELECTRONIC FORM, REPRODUCED BY ANY MEANS, OR USED FOR ANY PURPOSE WITHOUT WRITTEN CONSENT OF CUMMINS INC.		FOR INTERPRETATION OF DIMENSIONING AND TOLERANCING, SEE ASME Y14.5-2009	FIRST USED ON	PGF	CAD SHEET
± 1.0°	1/15			ARROW	D	A055V240	2 of 2

UNLESS OTHERWISE SPECIFIED,
ALL DIMENSIONS ARE IN INCHES

TOLERANCES:
FRACTIONAL: 1/4
X: .06
XX: .03
XXX: .01
ANGLES: .5

REFERENCES
A055J588
A055V238
A022V240

A055J590

PREP. BY: KDU
CHKD BY: -
MODIFIED BY: -
FINISH: N/A

08/12/25

ENGINE FAMILY:
QS18.9G ENGINE
ENCLOSURE FAMILY:
F216/F217/F231 ENCLOSURE

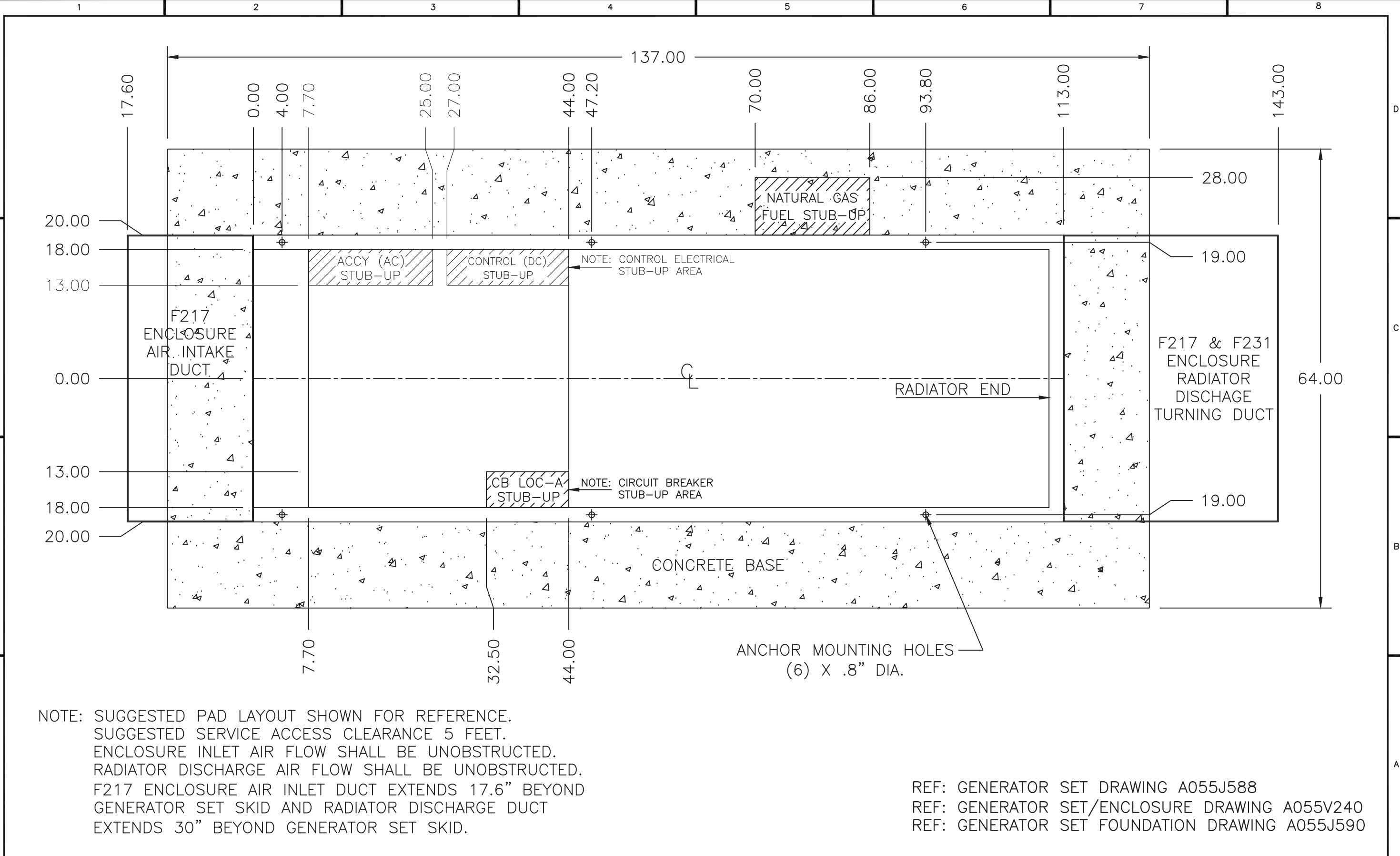

NOTE: SUGGESTED PAD LAYOUT SHOWN FOR REFERENCE.
SUGGESTED SERVICE ACCESS CLEARANCE 5 FEET.
ENCLOSURE INLET AIR FLOW SHALL BE UNOBSTRUCTED.
RADIATOR DISCHARGE AIR FLOW SHALL BE UNOBSTRUCTED.
F217 ENCLOSURE AIR INLET DUCT EXTENDS 17.6" BEYOND
GENERATOR SET SKID AND RADIATOR DISCHARGE DUCT
EXTENDS 30" BEYOND GENERATOR SET SKID.

REF: GENERATOR SET DRAWING A055J588
REF: GENERATOR SET/ENCLOSURE DRAWING A055V240
REF: GENERATOR SET FOUNDATION DRAWING A055J590



SITE NAME:	CONTACT NAME:	CUSTOMER PROJECT NO:	TITLE: 125 KW THRU 200 KW NATURAL GAS GENERATOR SETS F216..F217..F231 ENCLOSURES
CONTRACTOR NAME:	CONTACT NO:	CSSNA PROJECT NO:	SIZE: C DWG NO: C125 N6 THRU C200 N6B STUB-UP REV 2
			SCALE: NONE DO NOT SCALE PRINT SHEET 1 OF 1

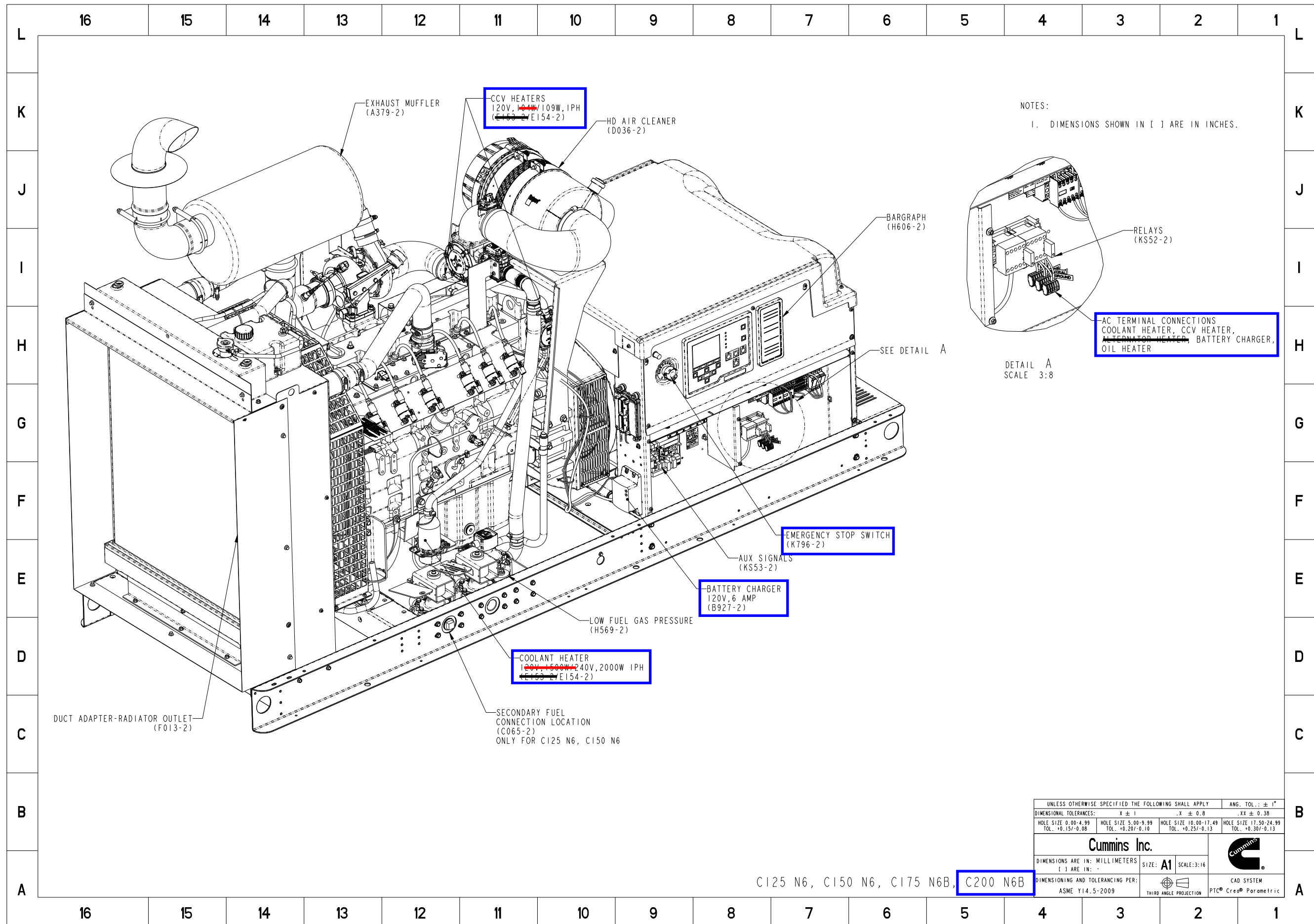

NOTES:
1. DIMENSIONS SHOWN IN [] ARE IN INCHES.

DETAIL A
SCALE 3:8

UNLESS OTHERWISE SPECIFIED THE FOLLOWING SHALL APPLY				ANG. TOL.: ± 1°
DIMENSIONAL TOLERANCES:				X ± 1
HOLE SIZE 0.00-4.99		HOLE SIZE 5.00-9.99		HOLE SIZE 10.00-17.49
TOL. +0.15/-0.08		TOL. +0.20/-0.10		TOL. +0.25/-0.13
				HOLE SIZE 17.50-24.99
				TOL. +0.30/-0.13
Cummins Inc.				Cummins
DIMENSIONS ARE IN: MILLIMETERS		SIZE: A1	SCALE: 3:16	
[] ARE IN: -		THIRD ANGLE PROJECTION		CAD SYSTEM PTC® Creo® Parametric
DIMENSIONING AND TOLERANCING PER: ASME Y14.5-2009				

C125 N6, C150 N6, C175 N6B, **C200 N6B**

Document Generated: 17AUG2022 19:55 GMT

Cummins Data Classification:
Cummins Confidential

This document (and the information shown thereon) is **Confidential and Proprietary** and shall not be disclosed to others in hard copy or electronic form, reproduced by any means, or used for any purpose without written consent of Cummins Inc.

Part Number: **A055J592** Part Revision: **C**
Part Name: **OUTLINE,GENSET**
Drawing Category: **Detail** State: **Released** Sheet 1 of 3

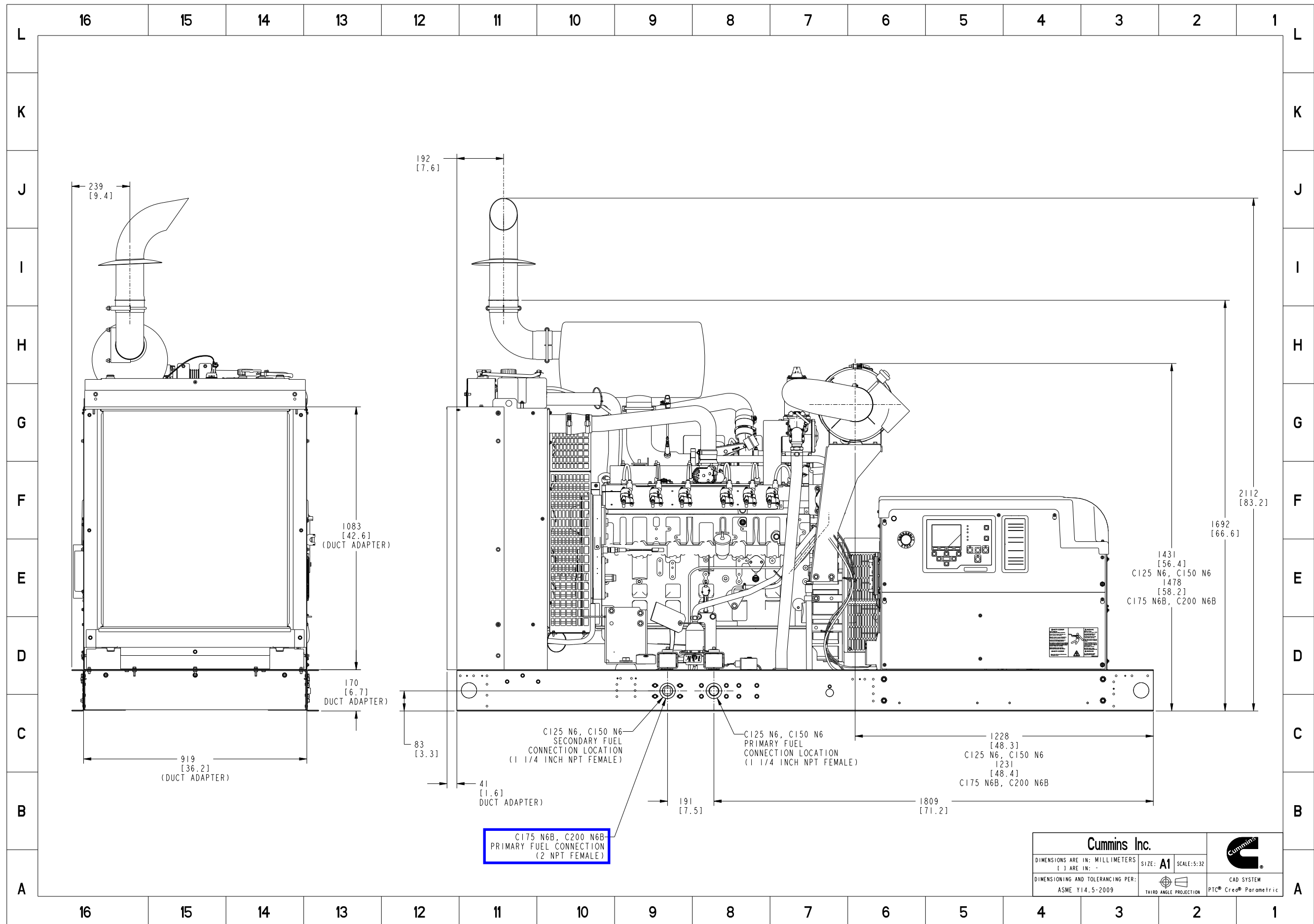

Document Generated: 17AUG2022 19:55 GMT

Cummins Data Classification:
Cummins Confidential

This document (and the information shown thereon) is **Confidential and Proprietary** and shall not be disclosed to others in hard copy or electronic form, reproduced by any means, or used for any purpose without written consent of Cummins Inc.

Part Number: **A055J592** Part Revision: **C**

Part Name: **OUTLINE,GENSET**

Drawing Category: **Detail** State: **Released** Sheet 2 of 3

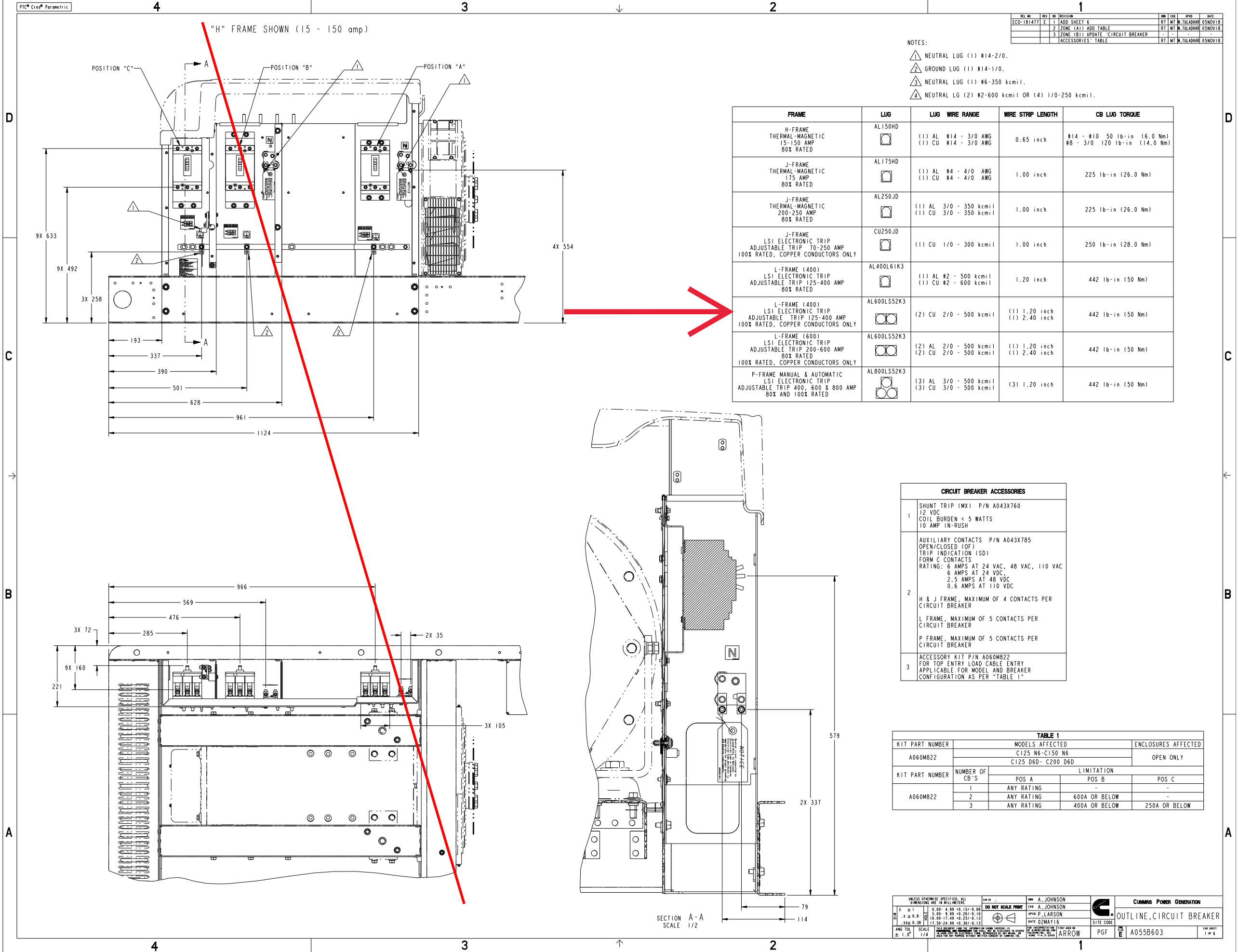

REV NO	REV	REVISION	REV	CD	APPD	DATE
ECO-181477	E	1	ADD SHEET 6	RT	MT, M. TULADHAN	05NOV18
		2	ZONE (A1) ADD TABLE	RT	MT, M. TULADHAN	05NOV18
		3	ZONE (B1) UPDATE 'CIRCUIT BREAKER ACCESSORIES' TABLE	RT	MT, M. TULADHAN	05NOV18

- NOTES:
- 1 NEUTRAL LUG (1) #14-2/0.
 - 2 GROUND LUG (1) #14-1/0.
 - 3 NEUTRAL LUG (1) #6-350 kcmil.
 - 4 NEUTRAL LG (2) #2-600 kcmil OR (4) 1/0-250 kcmil.

FRAME	LUG	LUG WIRE RANGE	WIRE STRIP LENGTH	CB LUG TORQUE
H-FRAME THERMAL-MAGNETIC 15-150 AMP 80% RATED	AL150HD	(1) AL #14 - 3/0 AWG (1) CU #14 - 3/0 AWG	0.65 inch	#14 - #10 50 lb-in (6.0 Nm) #8 - 3/0 120 lb-in (14.0 Nm)
J-FRAME THERMAL-MAGNETIC 175 AMP 80% RATED	AL175HD	(1) AL #4 - 4/0 AWG (1) CU #4 - 4/0 AWG	1.00 inch	225 lb-in (26.0 Nm)
J-FRAME THERMAL-MAGNETIC 200-250 AMP 80% RATED	AL250JD	(1) AL 3/0 - 350 kcmil (1) CU 3/0 - 350 kcmil	1.00 inch	225 lb-in (26.0 Nm)
J-FRAME LSI ELECTRONIC TRIP ADJUSTABLE TRIP 70-250 AMP 100% RATED, COPPER CONDUCTORS ONLY	CU250JD	(1) CU 1/0 - 300 kcmil	1.00 inch	250 lb-in (28.0 Nm)
L-FRAME (400) LSI ELECTRONIC TRIP ADJUSTABLE TRIP 125-400 AMP 80% RATED	AL400L61K3	(1) AL #2 - 500 kcmil (1) CU #2 - 600 kcmil	1.20 inch	442 lb-in (50 Nm)
L-FRAME (400) LSI ELECTRONIC TRIP ADJUSTABLE TRIP 125-400 AMP 100% RATED, COPPER CONDUCTORS ONLY	AL600LS2K3	(2) CU 2/0 - 500 kcmil	(1) 1.20 inch (1) 2.40 inch	442 lb-in (50 Nm)
L-FRAME (600) LSI ELECTRONIC TRIP ADJUSTABLE TRIP 200-600 AMP 80% RATED 100% RATED, COPPER CONDUCTORS ONLY	AL600LS2K3	(2) AL 2/0 - 500 kcmil (2) CU 2/0 - 500 kcmil	(1) 1.20 inch (1) 2.40 inch	442 lb-in (50 Nm)
P-FRAME MANUAL & AUTOMATIC LSI ELECTRONIC TRIP ADJUSTABLE TRIP 400, 600 & 800 AMP 80% AND 100% RATED	AL800LS2K3	(3) AL 3/0 - 500 kcmil (3) CU 3/0 - 500 kcmil	(3) 1.20 inch	442 lb-in (50 Nm)

CIRCUIT BREAKER ACCESSORIES	
1	SHUNT TRIP (MX) P/N A043X760 12 VDC COIL BURDEN < 5 WATTS 10 AMP IN-RUSH
2	AUXILIARY CONTACTS P/N A043X785 OPEN/CLOSED (OF) TRIP INDICATION (SD) FORM C CONTACTS RATING: 6 AMPS AT 24 VAC, 48 VAC, 110 VAC 6 AMPS AT 24 VDC, 2.5 AMPS AT 48 VDC, 0.6 AMPS AT 110 VDC H & J FRAME, MAXIMUM OF 4 CONTACTS PER CIRCUIT BREAKER L FRAME, MAXIMUM OF 5 CONTACTS PER CIRCUIT BREAKER P FRAME, MAXIMUM OF 5 CONTACTS PER CIRCUIT BREAKER
3	ACCESSORY KIT P/N A060M822 FOR TOP ENTRY LOAD CABLE ENTRY APPLICABLE FOR MODEL AND BREAKER CONFIGURATION AS PER "TABLE 1"

TABLE 1				
KIT PART NUMBER	MODELS AFFECTED	ENCLOSURES AFFECTED		
A060M822	C125 N6-C150 N6 C125 D6D- C200 D6D	OPEN ONLY		
KIT PART NUMBER	NUMBER OF CB'S	LIMITATION		
		POS A	POS B	POS C
A060M822	1	ANY RATING	-	-
	2	ANY RATING	600A OR BELOW	-
	3	ANY RATING	400A OR BELOW	250A OR BELOW

UNLESS OTHERWISE SPECIFIED, ALL DIMENSIONS ARE IN MILLIMETERS	DO NOT SCALE PRINT	APPD A. JOHNSON CDR A. JOHNSON APPD P. LARSON DATE 02MAY16	CUMMINS POWER GENERATION OUTLINE, CIRCUIT BREAKER
ANG TOL SCALE 1/4	SCALE 1/2	DATE 02MAY16	PGF A055B603

Regulatory Review and Approval is required prior to changing this item per PGG 1-01-01-116. This item impacts compliance with these External Regulations: UL, CSA

REV NO	REV	NO	REVISION	REV	NO	DATE
ECO-181477	E	-	-	RT	WT	N. TULADHAN 05NOV18

"L" FRAME SHOWN (400 - 600 amp)

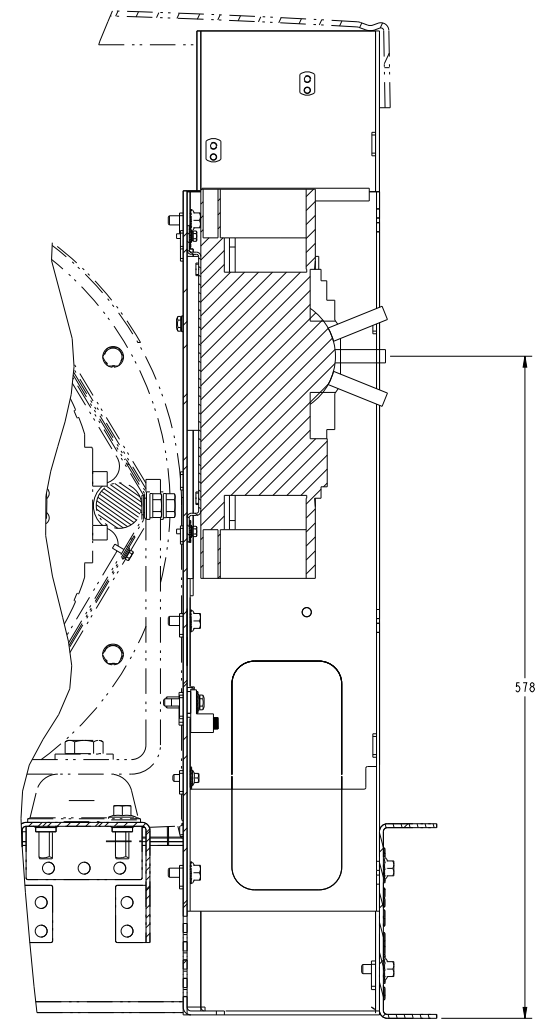
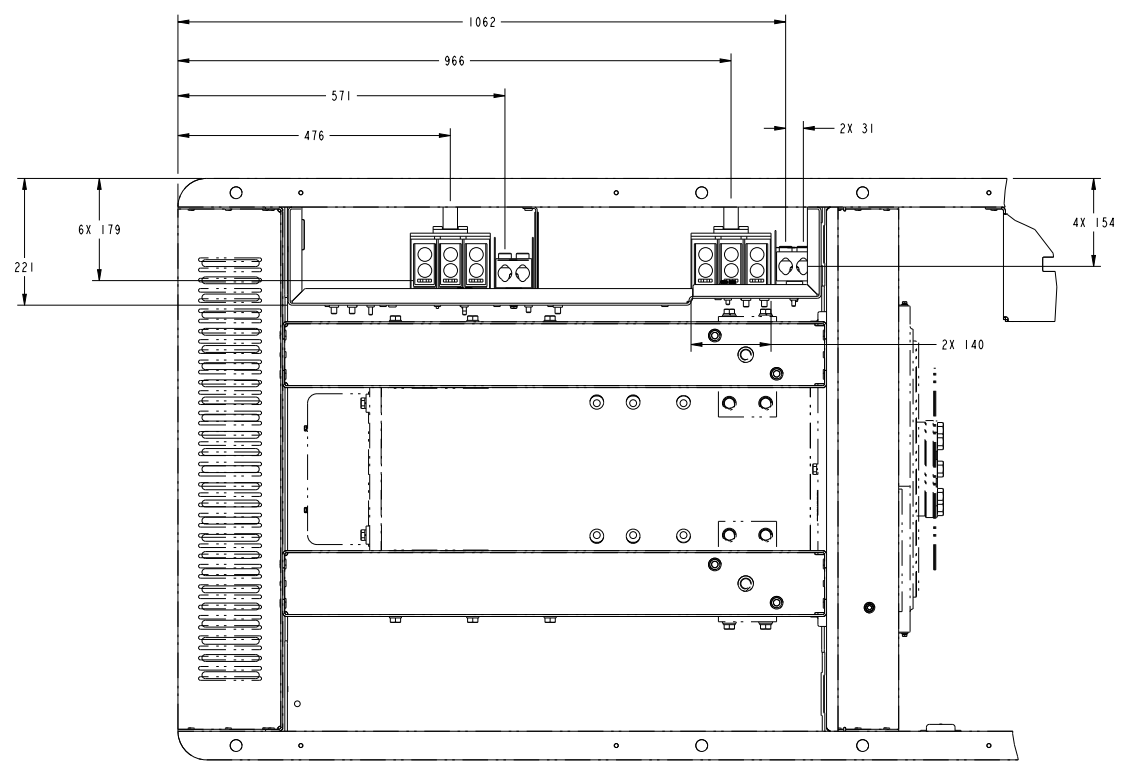
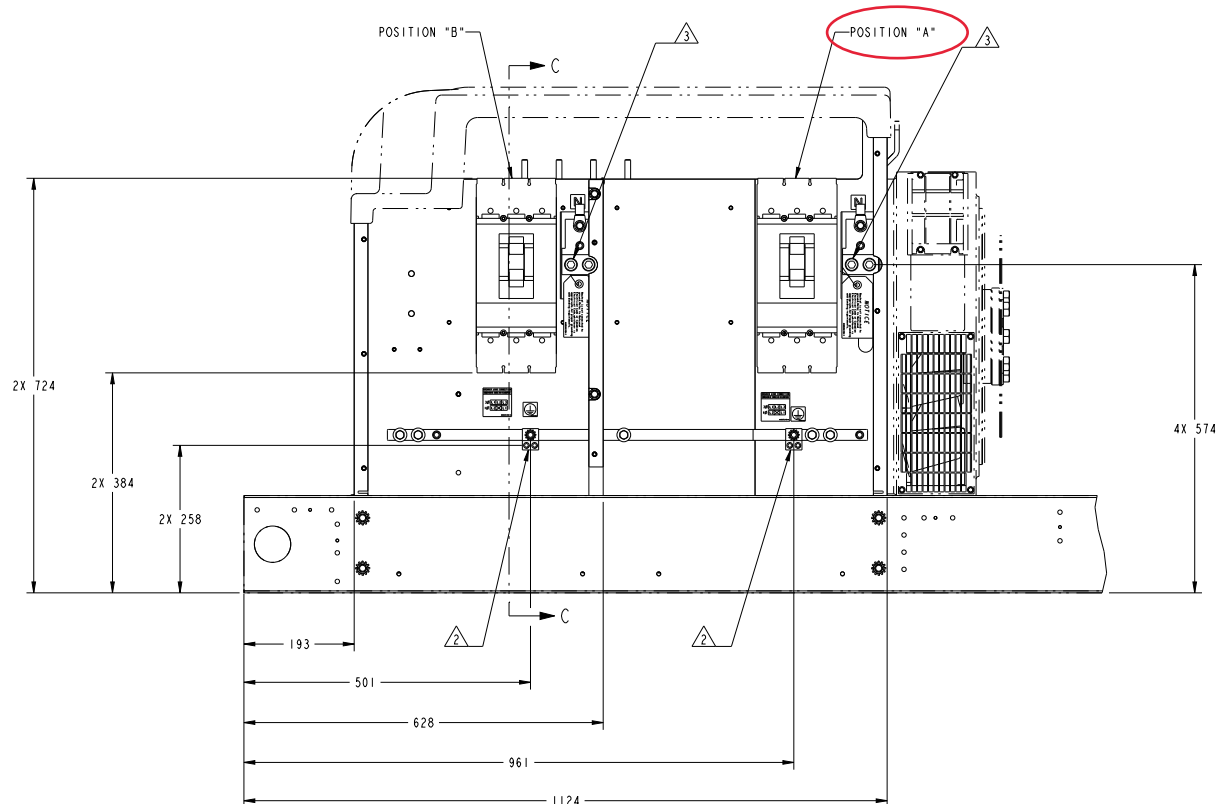

SECTION C - C
SCALE 1/2

UNLESS OTHERWISE SPECIFIED, ALL DIMENSIONS ARE IN MILLIMETERS		APP'D	CUMMINS POWER GENERATION	
± 1	0.00 - 4.99 +0.15/-0.00	A. JOHNSON	CUMMINS POWER GENERATION	OUTLINE, CIRCUIT BREAKER
± 0.8	5.00 - 9.99 +0.20/-0.10	A. JOHNSON		
± 0.5	10.00 - 17.49 +0.25/-0.13	P. LARSON	DATE	02MAY16
± 0.38	17.50 - 24.99 +0.30/-0.13		SITE CODE	
ANG TOL	SCALE	DATE	PGF	E
± 1.0°	1/4	02MAY16		A055B603

Regulatory Review and Approval is required prior to changing this item per PGG 1-01-01-116. This item impacts compliance with these External Regulations: UL,CSA

Drawing Name: A055B604 Revision: E
Part Name: A055B603 Revision: E
ECO-181477 Sheet 3 of 7

REV NO	REV	NO	REVISION	REV	NO	DATE
ECO-181477	E	-	-	RT	MT	05NOV18

"H" FRAME SHOWN (15 - 150 amp)

"L" FRAME SHOWN (400 - 600 amp)

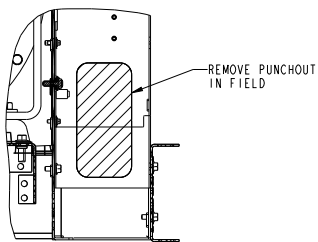
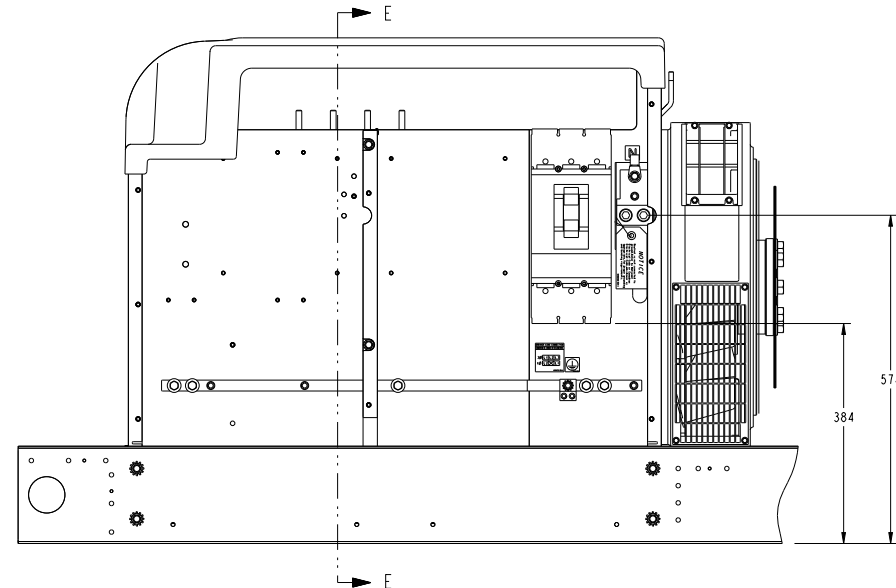
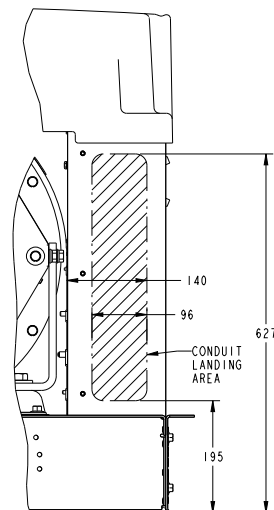
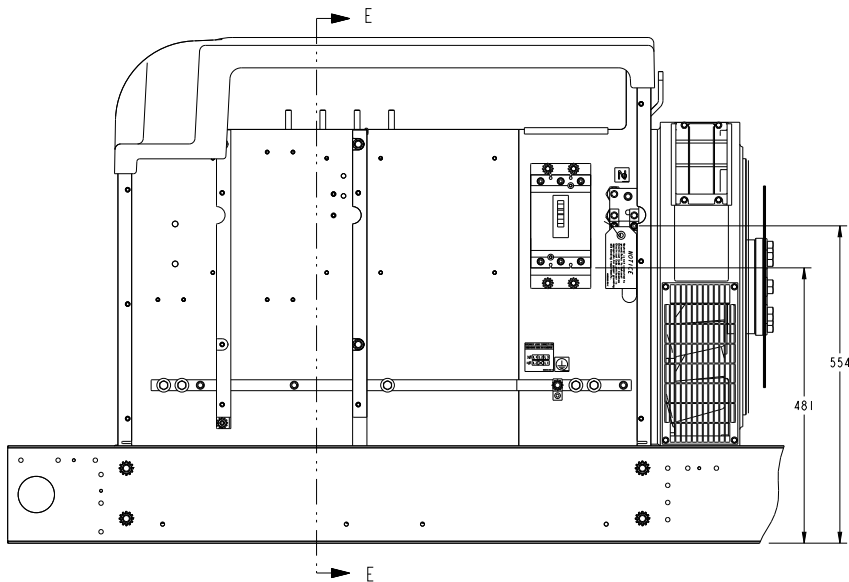
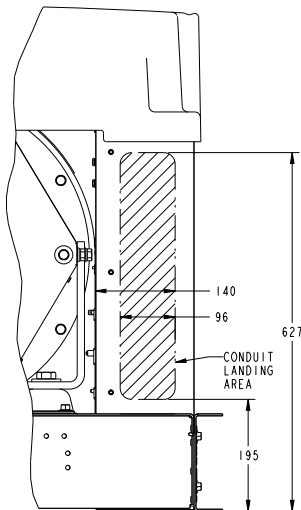

SECTION E-E

"J" FRAME SHOWN (175 - 250 amp)

"P" FRAME SHOWN (400-800 amp)

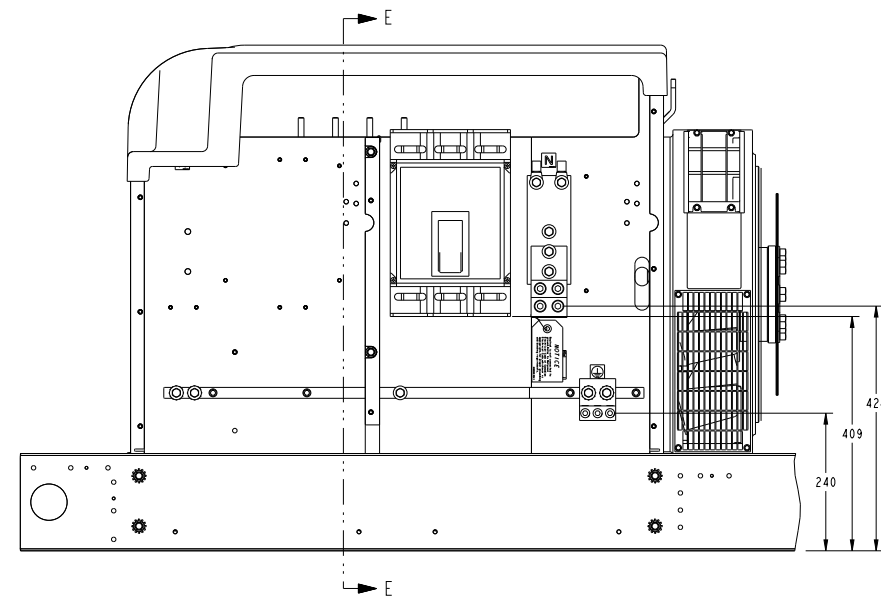
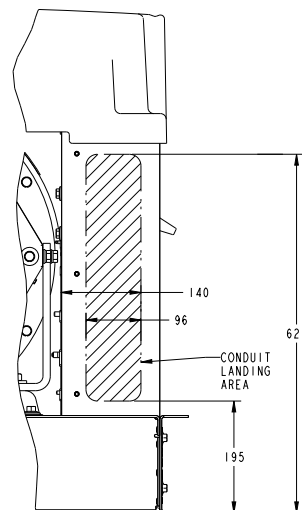
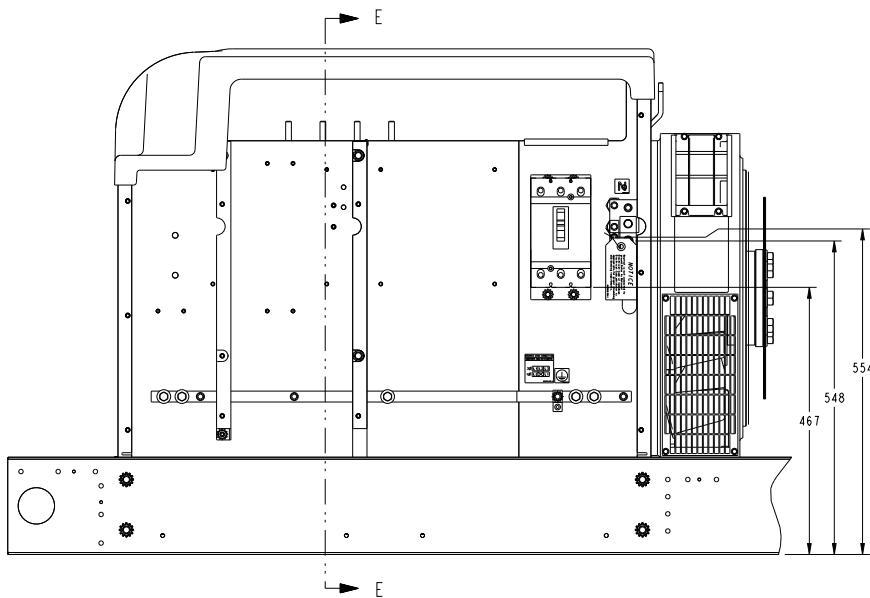
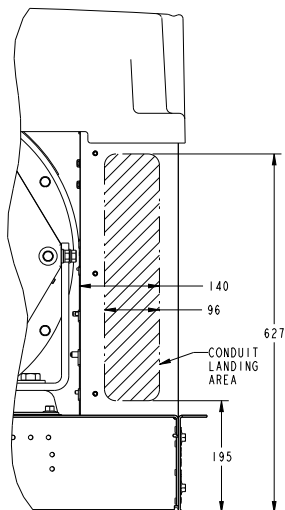

UNLESS OTHERWISE SPECIFIED, ALL DIMENSIONS ARE IN MILLIMETERS		DO NOT SCALE PRINT	APP'D A. JOHNSON	CUMMINS POWER GENERATION
± 0.1	0.00 - 4.99 ± 0.15 / 0.00		CAD A. JOHNSON	
± 0.2	5.00 - 9.99 ± 0.20 / 0.13		APP'D P. LARSON	OUTLINE, CIRCUIT BREAKER
± 0.38	10.00 - 17.49 ± 0.25 / 0.13		DATE 02MAY16	SITE CODE
	17.50 - 24.99 ± 0.30 / 0.13		PGF	A055B603
ANG TOL	SCALE	DATE	DATE	5 of 6
± 1.0°	1/4	02MAY16	02MAY16	

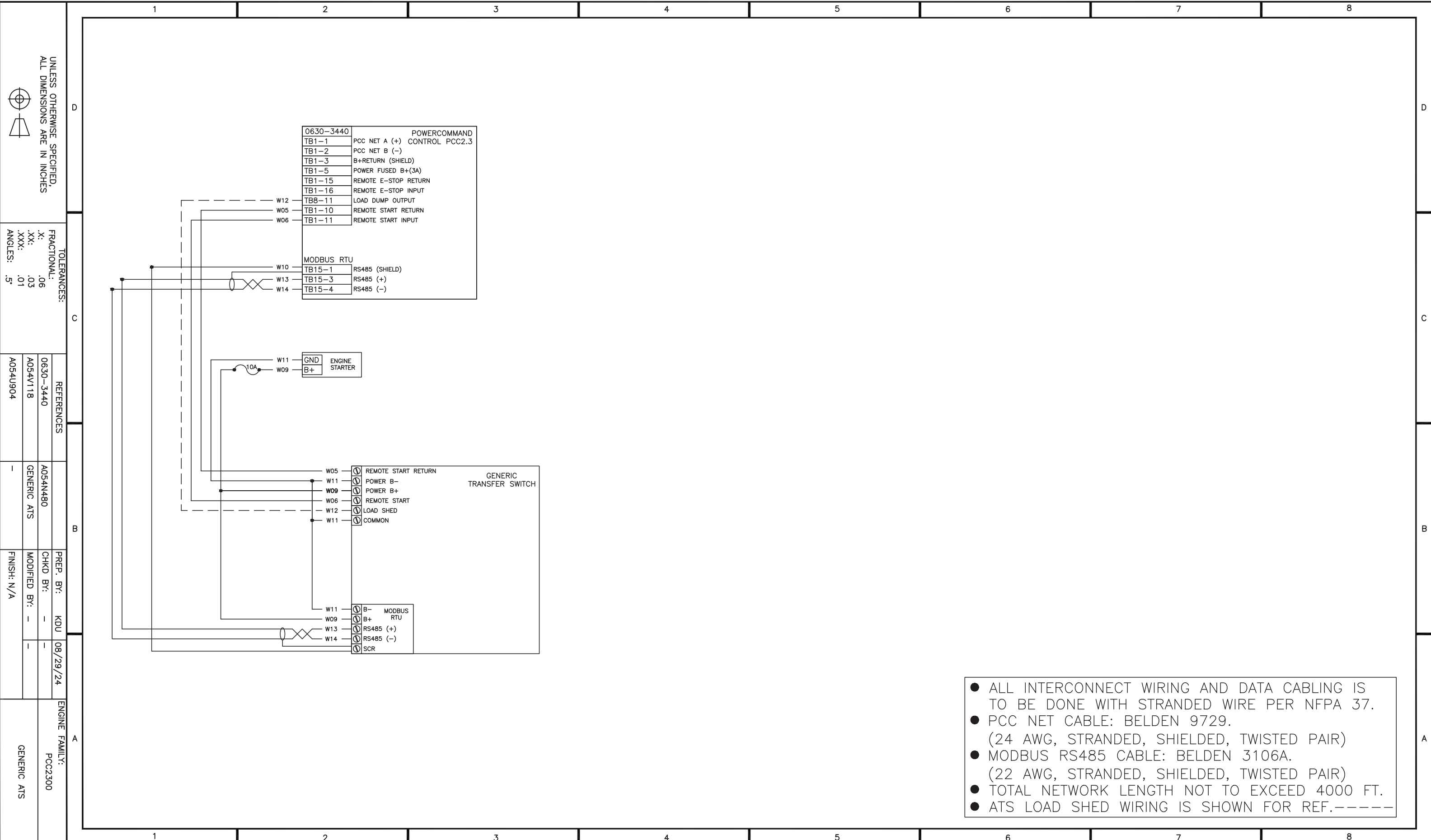

- ALL INTERCONNECT WIRING AND DATA CABLING IS TO BE DONE WITH STRANDED WIRE PER NFPA 37.
- PCC NET CABLE: BELDEN 9729.
(24 AWG, STRANDED, SHIELDED, TWISTED PAIR)
- MODBUS RS485 CABLE: BELDEN 3106A.
(22 AWG, STRANDED, SHIELDED, TWISTED PAIR)
- TOTAL NETWORK LENGTH NOT TO EXCEED 4000 FT.
- ATS LOAD SHED WIRING IS SHOWN FOR REF.-----

AC ACCESSORY LOAD TABLE

CUSTOMER AC CONNECTION TERMINALS

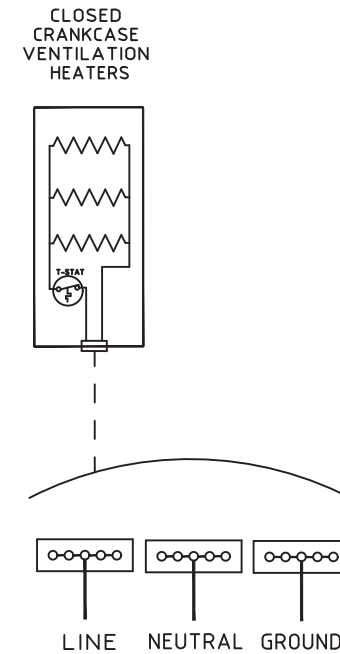
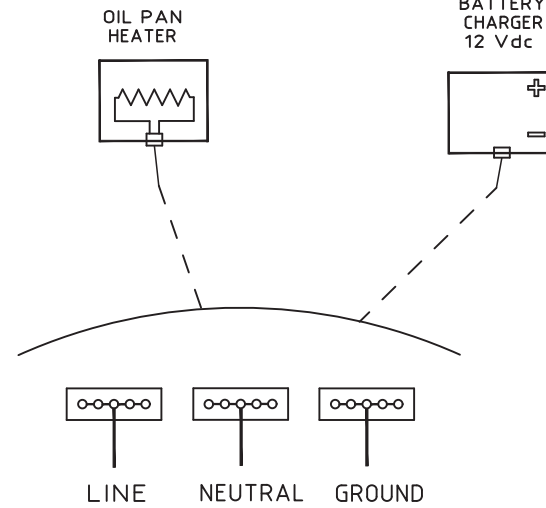
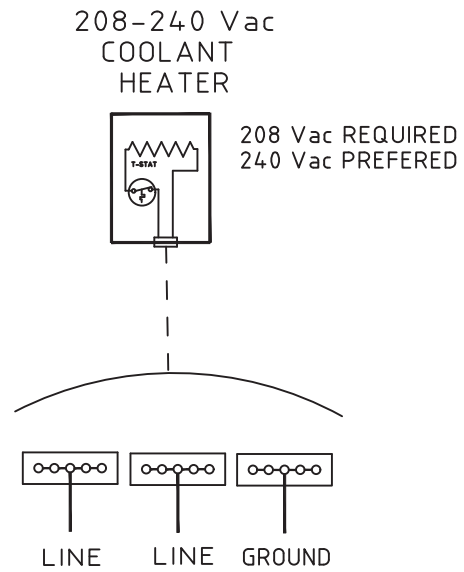

NOTES:

1. INSTALLER TO PROVIDE BRANCH CIRCUITS TO POWER ALL ACCESSORIES
2. ALL ACCESSORIES ARE SINGLE PHASE 120/240 Vac 60 Hz
3. FOLLOW REGIONAL REGULATIONS AND APPLICABLE ELECTRIC CODES FOR INSTALLATION
4. CCV HEATERS MUST BE CONNECTED TO A CONTINUOUSLY ENERGIZED CIRCUIT FROM BOTH UTILITY AND GENERATOR

COOLANT HEATER 2000 WATTS, 240 VAC, 8.4 AMPS /
1500 WATTS, 208VAC, 7.2 AMPS

CCV HEATERS 120 WATTS, 120VAC, 1.0 AMP

BATTERY CHARGER 192 WATTS, 120 VAC, 1.67 AMPS

OIL PAN HEATER 150 WATTS, 120VAC, 1.25 AMPS

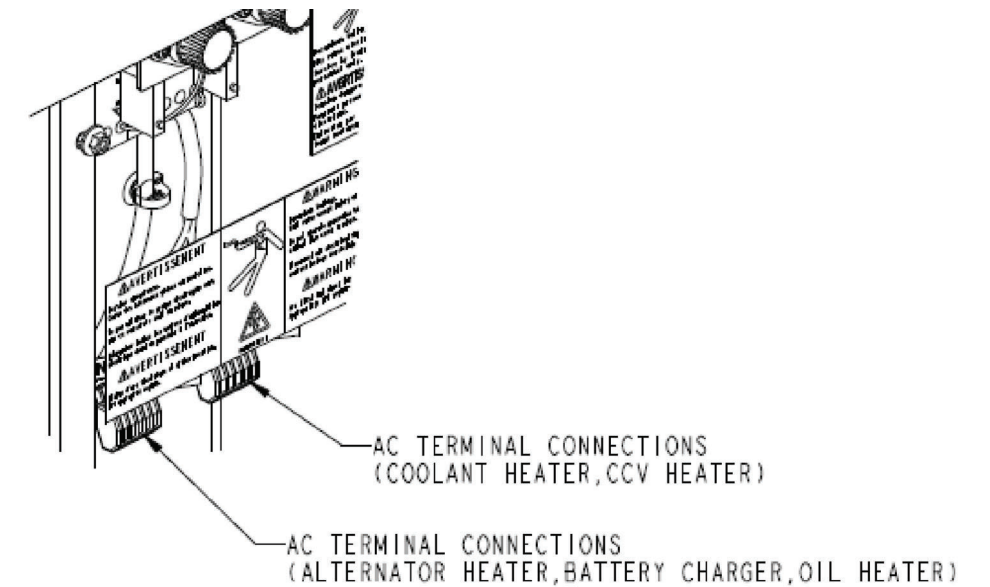

UNLESS OTHERWISE SPECIFIED,
ALL DIMENSIONS ARE IN INCHES

SECTION 5

Startup & Warranty





Cummins Sales and Service

Customer / Contractor Pre Commissioning Inspection Form

The intent of this form is for the contractor to prepare for equipment to be commissioned by a certified Cummins Field Service Power Generation Technician. Filling out this form is required and will minimize delays due to equipment failing to meet requirements. Completing this checklist in its entirety should minimize the need for additional billing beyond the previously provided commissioning quote.

The items listed are the responsibility of the contractor and not Cummins Sales and Service.

Project Name/End User: _____

Contractor: _____

Address: _____ Contact: _____

Business Phone: _____ Cell Phone: _____

Email: _____

ON SITE INFORMATION

On-Site Contact Information: _____

Address: _____

Time Requested Onsite: _____

Sub location of Generator (ie. Roof, basement, floor): _____

Does the facility have the following: Loading Dock Elevator

Access (from truck and load bank parking to generator in feet): _____

Parking: Is parking available on-site for service truck: Yes No

Permits: Have all necessary air quality and local permits been secured: Yes No N/A

Fuel Tank Testing: Is fuel tank testing required: Yes No

 If yes when is the inspector scheduled for: _____

ON SITE INFORMATION CONTINUED

YES	NA	NO

Is the facility occupied and is customer aware there will be power outages after generator is started?

Will there be any site safety training needed for technician prior to beginning? On site contact for training: _____

Will customer representative be on site for operator training?
On site contact for operator training: _____

MECHANICAL LOCATION AND PLACEMENT OF THE GENERATOR SET

YES	NA	NO

Generator is properly secured to pad or vibration isolators

Generator Enclosure and/or Room is free of all debris

No airflow obstructions to the engine or generator are present for cooling combustion (See Cummins T-030 or Installation manual of generator set)

Room is designed for adequate inlet and outlet airflow

GASEOUS FUEL Natural Gas/LP Vapor/LP Liquid

YES	NA	NO

Natural gas and/or LPG fuel supply is connected.

Fuel piping is the appropriate size based on full-load CFH/BTU requirement. Pipe size after service regulator: _____

Service regulator(s), (if supplied), fuel strainer(s), flexible fuel line(s) and manual shut off are installed

Fuel pressure after service regulator is: _____ inches of H2O

I have read and fully understand the fuel requirements for this equipment, I am verifying that the piping and fuel supply meets or exceeds those requirements. I also understand failure to meet the requirements will result in additional charges.

Contractor "requestor" Signature

Date

DIESEL FUELED GENERATORS

YES NA NO

Flexible fuel connections, (supply and return) are connected to generator and piping.

Day tank installed, wired and plumbed (lines free of obstruction) to genset and main fuel tank if applicable. Only black iron pipe for fuel lines, never use copper or galvanized pipe.

All tanks filled with enough fuel to perform startup and testing.

A return line from engine to day tank and day tank to main tank should be in place

EXHAUST SYSTEM

YES NA NO

Exhaust wrapped or isolated to prevent accidental activation of fire protection devices and sprinklers.

Exhaust flex-pipe is installed at engine exhaust outlet (The silencer and flex-pipe are supplied with the generator set).

Silencer is installed with appropriate supports (no weight should be placed on the exhaust outlet of the genset).

Exhaust system has proper expansion joints and wall thimbles (Thimbles are required for wall or roof penetration).

GENERATOR ELECTRICAL CONNECTIONS

YES NA NO

Load conductors connected to breakers

Flexible connections used on all conduit connections to the generator set output box

Remote start interconnection **stranded** wiring is installed between the generator set and the automatic transfer switch(s) and annunciator.

AC Power conductors in dedicated conduit separate from any DC control or network wiring

Ground fault connected/functioning on generator, if supplied

AC power wired to the coolant heaters (Do NOT energize)

Check for AC oil pan heater, control heater or generator winding heater (Needing AC wiring)

Generator is grounded in compliance with local codes

If applicable, louver motors are operational and connected to generator controls

GENERATOR ELECTRICAL CONNECTIONS CONTINUED

YES NA NO

Annunciator mounted in a location where someone can observe a fault of the remote generator system

Where is annunciator located? _____

Are there additional ancillary devices/equipment that need to be integrated into the system? If yes, please define _____

Battery charger mounted (free of vibration, weather, accessible for an operator to observe easily) and connected to the appropriate AC and DC wiring to operate the charger.

TRANSFER SWITCH ELECTRICAL CONNECTIONS

YES NA NO

Conductors connected for Utility, Load and Emergency

Remote start interconnection **stranded** wiring is installed between the generator set and the automatic transfer switch(s).

Four Pole Transfer Switch: Is generator neutral grounded?

DAY OF STARTUP

YES NA NO

Training of facility personnel will be done on the same day as start up. Additional trips for operational training will be an additional charge.

Can transfer switch be tested at time of generator startup? (There will be a power interruption) **Note: After hours testing could result in additional charges.**

If the associated switchgear and/or ATS(s) are not provided by Cummins, will the manufacturer's representative be on site?

Exercise with or without load? _____

If known, Transfer Time delay set recommendations Generator Set to exercise Day: _____ Time: _____

Contractor "requestor" Signature

Printed Name

Date: _____

Please complete this form and return to schedule start up, if not returned within 5 business days prior to scheduled startup it may be delayed. I understand that the start-up date may have to be rescheduled at my expense if the above items have not been completed properly.

Limited Warranty

Commercial Generating Set

This limited warranty applies to all Cummins Power Generation® branded commercial generating sets and associated accessories (hereinafter referred to as "Product").

This warranty covers any failures of the Product, under normal use and service, which result from a defect in material or factory workmanship.

Warranty Period:

The warranty start date[†] is the date of initial start up, first rental, demonstration or 18 months after factory ship date, whichever is sooner. See table for details.

Continuous Power (COP) is defined as being the maximum power which the generating set is capable of delivering continuously whilst supplying a constant electrical load when operated for an unlimited number of hours per year. No overload capability is available for this rating.

Prime Power (PRP) is defined as being the maximum power which a generating set is capable of delivering continuously whilst supplying a variable electrical load when operated for an unlimited number of hours per year. The permissible average power output over 24 hours of operation shall not exceed 70% of the PRP. For applications requiring permissible average output higher than stated, a COP rating should be used.

Limited-Time Running Power (LTP) is defined as the maximum power available, under the agreed operating conditions, for which the generating set is capable of delivering for up to 500 hours of operation per year.

Emergency Standby Power (ESP) is defined as the maximum power available during a variable electrical power sequence, under the stated operating conditions, for which a generating set is capable of delivering in the event of a utility power outage or under test conditions for up to 500 hours of operation per year. The permissible average power output over 24 hours of operation shall not exceed 70% of the ESP.

Environmental Protection Agency – Stationary Emergency (EPA-SE) is defined as being the maximum power available during a variable electrical power sequence, under the stated operating conditions, for which a generator set is capable of delivering in the event of a utility power outage or under test conditions and used in strict accordance with the EPA NSPS for stationary engines, 40 CFR part 60, subparts IIII and JJJJ, where a reliable utility must be present. The permissible average power output over 24 hours of operation shall not exceed 70% of the EPA-SE.

Data Center Continuous (DCC) is defined as the maximum power which the generator is capable of delivering continuously to a constant or varying electrical load for unlimited hours in a data center application.

Base Warranty Coverage Duration (Whichever occurs first)

Rating	Months	Max. Hours
COP	12	Unlimited
PRP	12	Unlimited
LTP	12	500 hrs
ESP	24	1000 hrs
EPA-SE	24	Unlimited
DCC	24	Unlimited

[†] Warranty start date for designated rental and oil and gas model Products is determined to be date of receipt of Product by the end customer.

Cummins Power Generation® Responsibilities:

In the event of a failure of the Product during the warranty period due to defects in material or workmanship, Cummins Power Generation® will only be responsible for the following costs:

- All parts and labor required to repair the Product.
- Reasonable travel expenses to and from the Product site location.
- Maintenance items that are contaminated or damaged by a warrantable failure.

Owner Responsibilities:

The owner will be responsible for the following:

- Notifying Cummins Power Generation® distributor or dealer within 30 days of the discovery of failure.
- Installing, operating, commissioning and maintaining the Product in accordance with Cummins Power Generation®'s published policies and guidelines.
- Providing evidence for date of commissioning.
- Providing sufficient access to and reasonable ability to remove the Product from the installation in the event of a warrantable failure.
- Incremental costs and expenses associated with Product removal and reinstallation resulting from non-standard installations.
- Costs associated with rental of generating sets used to replace the Product being repaired.
- Costs associated with labor overtime and premium shipping requested by the owner.
- All downtime expenses, fines, all applicable taxes, and other losses resulting from a warrantable failure.

Limitations:

This limited warranty does not cover Product failures resulting from:

- Inappropriate use relative to designated power rating.
- Inappropriate use relative to application guidelines.
- Inappropriate use of an EPA-SE application generator set relative to EPA's standards.
- Normal wear and tear.
- Improper and/or unauthorized installation.
- Negligence, accidents or misuse.
- Lack of maintenance or unauthorized repair.
- Noncompliance with any Cummins Power Generation® published guideline or policy.
- Use of improper or contaminated fuels, coolants or lubricants.
- Improper storage before and after commissioning.
- Owner's delay in making Product available after notification of potential Product problem.
- Replacement parts and accessories not authorized by Cummins Power Generation®.
- Use of Battle Short Mode.
- Owner or operator abuse or neglect such as: operation without adequate coolant or lubricants; overfueling; overspeeding; lack of maintenance to lubricating, cooling or air intake systems; late servicing and maintenance; improper storage, starting, warm-up, run-in or shutdown practices, or for progressive damage resulting from a defective shutdown or warning device.

- Damage to parts, fixtures, housings, attachments and accessory items that are not part of the generating set.

This limited warranty does not cover costs resulting from:

- Difficulty in gaining access to the Product.
- Damage to customer property.

A "Data center" is defined as a dedicated facility that house computers and associated equipment for data storage and data handling.

Reliable utility is defined as utility power without routine or regularly scheduled black-outs.

Please contact your local Cummins Power Generation® Distributor for clarification concerning these limitations.

CUMMINS POWER GENERATION® RIGHT TO FAILED COMPONENTS:

Failed components claimed under warranty remain the property of Cummins Power Generation®. Cummins Power Generation® has the right to reclaim any failed component that has been replaced under warranty.

Extended Warranty:

Cummins Power Generation® offers several levels of Extended Warranty Coverage. Please contact your local Cummins Power Generation® Distributor for details.

www.power.cummins.com

THE WARRANTIES SET FORTH HEREIN ARE THE SOLE WARRANTIES MADE BY CUMMINS POWER GENERATION® IN REGARD TO THE PRODUCT. CUMMINS POWER GENERATION® MAKES NO OTHER WARRANTIES, EXPRESS OR IMPLIED, OR OF MERCHANTABILITY OR FITNESS FOR A PARTICULAR PURPOSE.

IN NO EVENT IS CUMMINS POWER GENERATION® LIABLE FOR INCIDENTAL OR CONSEQUENTIAL DAMAGES.

This limited warranty shall be enforced to the maximum extent permitted by applicable law. This limited warranty gives the owner specific rights that may vary from state to state or from jurisdiction to jurisdiction.

Product Model Number: _____
 Product Serial Number: _____
 Date in Service: _____