



RECORD ONLY SUBMITTAL PACKAGE

**CSDG - 5024-5025 - CANTON, TX
(NEGOTIATED)**

Prepared For:

Central States Diesel Generators
1901 South Prairie Avenue
Waukesha, Wisconsin 53189

THIS SUBMITTAL IS BEING PREPARED FOR RECORD PURPOSES ONLY

The information presented in this submittal package has been approved

and is provided for record purposes only.

Date: 4/28/2026

Opportunity # O-798997

BMS# 480719

Customer PO# Signed Quote/5023-5025



Serving Cummins Customers
cummins.com/sales-and-service



DISCLAIMER



Serving Cummins Customers

Cummins power solutions are supported by the largest and best-trained worldwide certified sales/distributor network in the industry. This network will help you select and install the critical power solution to meet the requirements of your specific application. This same network provides experts with advanced technology to make your life easier while providing a seamless support experience.

IMPORTANT: *The critical power solution information and specifications included in this pdf can be used by the site contractor(s) and/or engineer(s) to assist with planning for and accomplishing the overall power solution installation. Please forward this document to the appropriate personnel, as necessary.*

It is the obligation of the electrical contractor and reviewing engineer to determine that the item quantities and accuracy of this submittal is correct as required for the job. Any inaccuracies or deviations must be addressed with Cummins Inc. before release to manufacturing. Any releases of material to manufacturing by the above parties constitute an acceptance of the accuracy of the submittal. Any changes after release will be viewed as a change order, subject to pricing changes. Please take the time to review this package for accuracy to prevent any after-shipment problems that could cause delay in energization.

Cummins certifies that these drawings, material lists, specification and datasheets have been checked prior to submittal and they:

- accurately depict the proposed equipment*
- provide current information to the date of the submittal and*
- present true and accurate equipment information.*

This Approval Drawing Package is submitted as our interpretation of the project requirements and/or the specifications for this job. Please note that issuance of these submittals shall not be deemed or interpreted as performance nor acceptance of your purchase order terms and conditions.

For questions or comments regarding this submittal, please contact the Cummins Project Manager listed on the title page.

TABLE OF CONTENTS



Section 1 - Project Information

Project Bill of Material

Section 2 - Generator Specification Sheets

Generator Specification Sheet (C100D6C) Qty 2

Generator Data Sheet

PowerCommand Control (PCC) Specification Sheet

Alternator Data Sheet

Sound Data Sheet

Cooling System Data Sheet

Exhaust Emission Compliance Statement

Exhaust Emission Data Sheet

Prototype Test Summary Report

Section 3 - Generator Accessories

Circuit Breaker Data Sheet

Fuel Tank Specification Sheet

Sound Level2 Baffle, Shipped Loose (A052M018)

Section 4 - Generator Drawings and Interconnects

Enclosure Outline Drawing

Generator Outline Drawing

Foundation Outline Drawing

Fuel Tank Outline Drawing

Generator Options Outline Drawing

Circuit Breaker Outline Drawing

AC Interconnection Wiring Diagram

Section 5 - Warranty

Generator Warranty Statement

SECTION 1

Project Information



Bill of Material

Feature Code	Description	Qty
C100D6C	C100D6C Diesel Genset, 60Hz, 100kW	2
C100 D6C	C100D6C, Diesel Genset, 60Hz, 100kW	
Install-US-Stat	U.S. EPA, Stationary Emergency Application	
A331-2	Duty Rating - Standby Power (ESP)	
L169-2	Emission Certification, EPA, Tier 3, NSPS CI Stationary Emergency	
L090-2	Listing - UL 2200	
H527-2	Warning - Low Coolant Level	
L193-2	NFPA 110 Type 10 Level 1 Capable	
B184-2	Exciter/Regulator - Permanent Magnet Generator, 3 Phase Sensor	
R002-2	Voltage - 277/480, 3 Phase, Wye, 4 Wire	
BB95-2	Alternator - 60Hz, 12L, 480/277V, 105C, 40C Ambient, Increased Motor Starting (IMS)	
F217-2	Aluminum Sound Attenuated Level 2 Enclosure, with Exhaust System	
P176-2	Enclosure Color - Green, Aluminum	
F252-2	Enclosure - Wind Load 180 MPH, ASCE7-10	
F179-2	Skidbase - Housing Ready	
C301-2	Fuel Tank - Regional, Dual Wall, Sub Base, 24 Hour Minimum	
C127-2	Fuel Water Separator	
C310-2	Low Fuel Level Switch, 40%	
C312-2	Mechanical Fuel Gauge	
C318-2	Switch - Fuel Tank, Rupture Basin	
H609-2	Control Mounting - Left Facing	
H700-2	PowerCommand 1.1 Controller	
H012-2	Gauge - Oil Pressure	
K796-2	Stop Switch - Emergency	
H536-2	Control Display Language - English	
KV03-2	Load Connection - Single	

KX26-2	Circuit Breaker, Location A, 70A - 250A, 3P, LSI, 600 Volts AC, 100%, UL
2800	Circuit Breaker or Terminal Box (Position B) - None
BB89-2	6A Battery Charger
A366-2	Engine Governor - Electronic, Isochronous
A422-2	Engine Starter - 12 Volt DC Motor
D041-2	Engine Air Cleaner - Normal Duty
A333-2	Battery Charging Alternator
E125-2	Engine Cooling - Radiator, High Ambient Air Temperature, Ship Fitted
E089-2	Extension - Coolant Drain
H669-2	Engine Coolant - 50% Antifreeze, 50% Water Mixture
E153-2	Coolant Heater, Cold Ambient
H706-2	Engine Oil
L028-2	Genset Warranty - 2 Years Base
L050-2	Literature - English
A322-2	Packing - Skid, Poly Bag
H268-2	Extension - Oil Drain
L260-2	Green Sound Level 2 Intake Baffle - Ship Loose
A052M018-FRD	Sound Level2 Baffle, Shipped Loose

--	--	--

Feature Code	Description	Qty
C25N6	C25N6, 25kW, 60Hz, Standby, Propane Genset, 1800rpm engine	1
Install-US-Stat	U.S. EPA, Stationary Emergency Application	
A331-2	Duty Rating-Standby Power	
L155-2	Emissions Certification-Spark Ignited, EPA, Emergency, Stationary, 40CFR60	
L090-2	Listing - UL 2200	
L228-2	Certification-Seismic, IBC2000, IBC2003, IBC2006, IBC2009, IBC2012	
L193-2	NFPA 110 Type 10 Level 1 Capable	
B240-2	Exciter/Reg - Torque Match	
R104-2	Voltage - 120/240, 1 Phase, 3 Wire	
B949-2	Alternator - 60Hz, 4L, 240/120V, 1 Phase, 120C, 40C Ambient	
F179-2	Skidbase-Housing Ready	
F231-2	Enclosure-Aluminum, Sound Attenuated, Level 1, with Exhaust System	

F252-2	Enclosure - Wind Load 180MPH, ASCE7-10
P178-2	EnclosureColor-Sandstone,Alum Encl
F253-2	Rack, Larger Battery
H608-2	Control Mounting - Right Facing
H700-2	PowerCommand 1.1 Controller
H001-2	Shutdown-Low Oil Press
H536-2	Display Language-English
KV03-2	Load Connection-Single
KV16-2	Circuit Breaker, Location A,125A, 2P, 600VAC, 80%, UL
A366-2	Engine Governor - Electronic, Isochronous
C284-2	Single Gas Fuel - Natural Gas or LP Vapor
A422-2	Engine Starter-12VDC Motor
D041-2	Engine Air Cleaner - Normal Duty
A333-2	Battery Charging Alternator
BB89-2	Battery Charger - 6 Amp, Regulated
E125-2	Engine Cooling-High Ambient Air Temperature
H389-2	Shutdown-Low Coolant Level
E089-2	Extension-Coolant Drain
H669-2	Engine Coolant - 50% Antifreeze, 50% Water Mixture
E154-2	Coolant Heater, Extreme Cold Ambient
H706-2	Engine Oil
L028-2	Genset Warranty – 2 Years Base
L050-2	Literature-English
A322-2	Packing-Skid,Poly Bag
H268-2	Extension-Oil Drain
A043J733-FRD	Enclosure Kit-Polymer Sandstone, Sound Level 1 to Sound Level 2

EXCEPTIONS AND CLARIFICATIONS:

Proposal is for equipment only, offloading, rigging, and installation by others.

Fuel and permits, unless listed above, is not included.

Cummins Standard Start-up and testing is included. Additional tests, such as NETA testing, if required, is by others

Coordination Study not provided.

NOTES:

SECTION 2

Generator Specifications



Qty 2

Specification Sheet



Diesel Generator Set

QSB5 Series Engine

50-125 kW Standby

EPA Tier 3 Emissions



Description

Cummins® generator sets are fully integrated power generation systems providing optimum performance, reliability and versatility for stationary Standby applications.

Features

Heavy duty engine - Rugged 4-cycle industrial diesel delivers reliable power and fast response to load changes.

Alternator - Several alternator sizes offer selectable motor starting capability with low reactance 2/3 pitch windings, low waveform distortion with non-linear loads and fault clearing short-circuit capability.

Control system - The PowerCommand® 1.1 electronic control is standard equipment and provides total generator set system integration including automatic remote starting/stopping, precise frequency and voltage regulation, alarm and status message display, output metering, auto-shutdown at fault detection and NFPA 110 Level 1 compliance. The PowerCommand 2.3 control is also optional and is UL 508 Listed and provides AmpSentry™ protection.

Cooling system - Standard cooling package provides reliable running at up to 50 °C (122 °F) ambient temperature.

Enclosures - The aesthetically appealing enclosure incorporates special designs that deliver one of the quietest generators of its kind. Aluminium material plus durable powder coat paint provides the best anti-corrosion performance. **The generator set enclosure has been evaluated to withstand 180 MPH wind loads in accordance with ASCE7 -10.** The design has hinged doors to provide easy access for service and maintenance.

Fuel tanks - Dual wall sub-base fuel tanks are offered as optional features, providing economical and flexible solutions to meet extensive code requirements on diesel fuel tanks.

NFPA - The generator set accepts full rated load in a single step in accordance with NFPA 110 for Level 1 systems.

Warranty and service - Backed by a comprehensive warranty and worldwide distributor network.

Model	Standby 60 Hz		Prime 60 Hz		Data sheets
	kW	kVA	kW	kVA	
C50D6C	50	63	45	56	NAD-6333-EN
C60D6C	60	75	54	68	NAD-6334-EN
C80D6C	80	100	72	90	NAD-6335-EN
C100D6C	100	125	90	113	NAD-6336-EN
C125D6C	125	156	112.5	141	NAD-6216-EN

Our energy working for you.™

©2019 Cummins Inc. | NAS-6211-EN - 06DEC2019.DOCX (12/19) A055Y560

power.cummins.com

Generator Set Specifications

Governor regulation class	ISO8528 Part 1 Class G3
Voltage regulation, no load to full load	± 1.0%
Random voltage variation	± 1.0%
Frequency regulation	isochronous
Random frequency variation	± 0.50%
Radio frequency emissions compliance	FCC code title 47 part 15 class A and B

Engine Specifications

Design	Turbocharged and charge air cooled
Bore	107 mm (4.21 in.)
Stroke	124 mm (4.88 in.)
Displacement	4.5 L (272 in ³)
Cylinder block	Cast iron, in-line 4 cylinder
Battery capacity	850 amps per battery at ambient temperature of 0 °C (32 °F)
Battery charging alternator	100 amps
Starting voltage	2 x 12 volt in parallel, negative ground
Lube oil filter type(s)	Spin-on with relief valve
Standard cooling system	High ambient radiator
Rated speed	1800 rpm

Alternator Specifications

Design	Brushless, 4 pole, drip proof, revolving field
Stator	2/3 pitch
Rotor	Direct coupled, flexible disc
Insulation system	Class H per NEMA MG1-1.65
Standard temperature rise	120 °C (248 °F) Standby
Exciter type	Torque match (shunt) with PMG as option
Alternator cooling	Direct drive centrifugal blower
AC waveform Total Harmonic Distortion (THDV)	< 5% no load to full linear load, < 3% for any single harmonic
Telephone Influence Factor (TIF)	< 50 per NEMA MG1-22.43
Telephone Harmonic Factor (THF)	< 3%

Available Voltages

1-phase		3-phase			
• 120/240	• 120/208	• 120/240	• 277/480	• 347/600	• 127/220

Generator Set Options

Fuel system

- Basic fuel tanks
- **Regional fuel tanks**

Engine

- **Engine air cleaner – normal** or heavy duty
- Shut down – low oil pressure
- **Extension – oil drain**
- Engine oil heater

Alternator

- 120 °C temperature rise alternator
- **105 °C temperature rise alternator**
- **PMG excitation**
- Alternator heater, 120 V
- Reconnectable full 1 phase output alternator

Control

- AC output analog meters
- **Stop switch – emergency**
- Auxiliary output relays (2)
- Auxiliary configurable signal inputs (8) and relay outputs (8)

Electrical

- **One, two or three circuit breaker configurations**
- 80% rated circuit breakers
- 80% or **100% rated LSI circuit breakers**
- Battery charger

Enclosure

- **Sound Level 1 or Level 2 enclosure, sandstone or green color**
- Weather protective enclosure with muffler installed, green color
- Winter protective enclosure, green color

Cooling system

- Shutdown – low coolant level
- **Warning – low coolant level**
- **Extension – coolant drain**
- **Coolant heater options:**
 - <4 °C (40 °F) – cold weather
 - <-18 °C (0 °F) – extreme cold

Exhaust system

- Exhaust connector NPT
- Exhaust muffler mounted

Generator set application

- Base barrier – elevated genset
- Radiator outlet duct adapter

Warranty

- **Base warranty – 2 year/1000 hours, Standby**
- Base warranty – 1 year/unlimited hours, Prime
- 3 year Standby warranty options
- 5 year Standby warranty options

Generator Set Accessories

- **Coolant heater**
- Battery heater kit
- Engine oil heater
- Remote control displays
- Auxiliary output relays (2)
- Auxiliary configurable signal inputs (8) and relay outputs (8)
- Annunciator – RS485
- Audible alarm
- Remote monitoring device – PowerCommand 500/550
- **Battery charger** – stand-alone, 12 V
- **Circuit breakers**
- Enclosure Sound Level 1 to Sound Level 2 upgrade kit
- Base barrier – elevated generator set
- **Mufflers** – industrial, residential or critical
- **Alternator PMG excitation**
- Alternator heater

Control System PowerCommand 1.1



PowerCommand control is an integrated generator set control system providing voltage regulation, engine protection, operator interface and isochronous governing (optional). Major features include:

- Battery monitoring and testing features and smart starting control system.
- Standard PCCNet interface to devices such as remote annunciator for NFPA 110 applications.
- Control boards potted for environmental protection.
- Control suitable for operation in ambient temperatures from -40 °C to +70 °C (-40 °F to +158 °F) and altitudes to 5000 meters (13,000 feet).
- Prototype tested; UL, CSA, and CE compliant.
- InPower™ PC-based service tool available for detailed diagnostics.

Operator/display panel

- Manual off switch
- Alpha-numeric display with pushbutton access for viewing engine and alternator data and providing setup, controls and adjustments (English or international symbols)
- LED lamps indicating generator set running, not in auto, common warning, common shutdown, manual run mode and remote start
- Suitable for operation in ambient temperatures from -40 °C to +70 °C
- Bargraph display (optional)

AC protection

- Over current warning and shutdown
- Over and under voltage shutdown
- Over and under frequency shutdown
- Over excitation (loss of sensing) fault
- Field overload

Engine protection

- Overspeed shutdown
- Low oil pressure warning and shutdown
- High coolant temperature warning and shutdown
- Low coolant level warning or shutdown

- Low coolant temperature warning
- High, low and weak battery voltage warning
- Fail to start (over crank) shutdown
- Fail to crank shutdown
- Redundant start disconnect
- Cranking lockout
- Sensor failure indication
- Low fuel level warning or shutdown

Alternator data

- Line-to-Line and Line-to-neutral AC volts
- 3-phase AC current
- Frequency
- Total kVA

Engine data

- DC voltage
- Lube oil pressure
- Coolant temperature
- Engine speed

Other data

- Generator set model data
- Start attempts, starts, running hours
- Fault history
- RS485 Modbus® interface
- Data logging and fault simulation (requires InPower service tool)

Digital governing (optional)

- Integrated digital electronic isochronous governor
- Temperature dynamic governing

Digital voltage regulation

- Integrated digital electronic voltage regulator
- 2-phase Line-to-Line sensing
- Configurable torque matching

Control functions

- Time delay start and cooldown
- Cycle cranking
- PCCNet interface
- (2) Configurable inputs
- (2) Configurable outputs
- Remote emergency stop
- Automatic Transfer Switch (ATS) control
- Generator set exercise, field adjustable

Options

- Auxiliary output relays (2)
- Remote annunciator with (3) configurable inputs and (4) configurable outputs
- **PMG alternator excitation**
- PowerCommand 500/550 for remote monitoring and alarm notification (accessory)
- Auxiliary, configurable signal inputs (8) and configurable relay outputs (8)
- AC output analog meters (bargraph)
 - Color-coded graphical display of:
 - 3-phase AC voltage
 - 3-phase current
 - Frequency
 - kVa
- Remote operator panel
- PowerCommand 2.3 control with AmpSentry protection

Ratings Definitions

Emergency Standby Power (ESP):

Applicable for supplying power to varying electrical load for the duration of power interruption of a reliable utility source. Emergency Standby Power (ESP) is in accordance with ISO 8528. Fuel Stop power in accordance with ISO 3046, AS 2789, DIN 6271 and BS 5514.

Limited-Time Running Power (LTP):

Applicable for supplying power to a constant electrical load for limited hours. Limited Time Running Power (LTP) is in accordance with ISO 8528.

Prime Power (PRP):

Applicable for supplying power to varying electrical load for unlimited hours. Prime Power (PRP) is in accordance with ISO 8528. Ten percent overload capability is available in accordance with ISO 3046, AS 2789, DIN 6271 and BS 5514.

Base Load (Continuous) Power (COP):

Applicable for supplying power continuously to a constant electrical load for unlimited hours. Continuous Power (COP) in accordance with ISO 8528, ISO 3046, AS 2789, DIN 6271 and BS 5514.

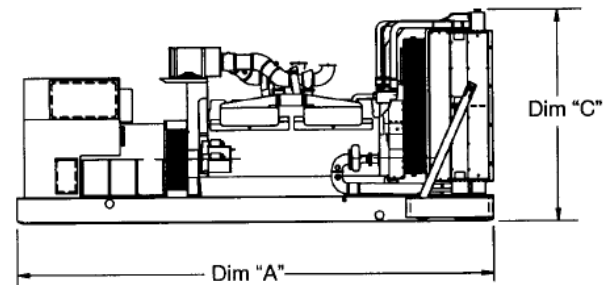
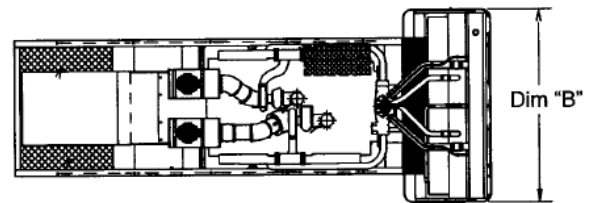

This outline drawing is for reference only. See respective model data sheet for specific model outline drawing number.

Do not use for installation design





Model	Dim "A" mm (in.)	Dim "B" mm (in.)	Dim "C" mm (in.)	Set weight* kg (lbs.)
Open set				
C50D6C	2482 (98)	1016 (40)	1321 (52)	958 (2113)
C60D6C	2482 (98)	1016 (40)	1321 (52)	1006 (2217)
C80D6C	2482 (98)	1016 (40)	1321 (52)	1054 (2324)
C100D6C	2482 (98)	1016 (40)	1321 (52)	1106 (2439)
C125D6C	2482 (98)	1016 (40)	1321 (52)	1173 (2586)
Weather protective enclosure				
C50D6C	2482 (98)	1016 (40)	1473 (58)	1039 (2290)
C60D6C	2482 (98)	1016 (40)	1473 (58)	1087 (2396)
C80D6C	2482 (98)	1016 (40)	1473 (58)	1135 (2503)
C100D6C	2482 (98)	1016 (40)	1473 (58)	1187 (2618)
C125D6C	2482 (98)	1016 (40)	1473 (58)	1254 (2765)
Sound attenuated enclosure Level 1				
C50D6C	3016 (119)	1016 (40)	1473 (58)	1221 (2693)
C60D6C	3016 (119)	1016 (40)	1473 (58)	1137 (2507)
C80D6C	3016 (119)	1016 (40)	1473 (58)	1185 (2614)
C100D6C	3016 (119)	1016 (40)	1473 (58)	1237 (2729)
C125D6C	3016 (119)	1016 (40)	1473 (58)	1304 (2876)
Sound attenuated enclosure Level 2				
C50D6C	3456 (136)	1016 (40)	1473 (58)	1228 (2708)
C60D6C	3456 (136)	1016 (40)	1473 (58)	1144 (2522)
C80D6C	3456 (136)	1016 (40)	1473 (58)	1192 (2629)
C100D6C	3456 (136)	1016 (40)	1473 (58)	1244 (2744)
C125D6C	3456 (136)	1016 (40)	1473 (58)	1311 (2891)
Winter protective enclosure				
C50D6C	3701 (146)	1016 (40)	1473 (58)	1254 (2758)
C60D6C	3701 (146)	1016 (40)	1473 (58)	1169 (2572)
C80D6C	3701 (146)	1016 (40)	1473 (58)	1218 (2679)
C100D6C	3701 (146)	1016 (40)	1473 (58)	1270 (2794)
C125D6C	3701 (146)	1016 (40)	1473 (58)	1337 (2941)

Refer to drawings for specific weights and dimensions

* Weights above are average. Actual weight varies with product configuration.

Codes and Standards

Codes or standards compliance may not be available with all model configurations – consult factory for availability.

	<p>This generator set is designed in facilities certified to ISO 9001 and manufactured in facilities certified to ISO 9001 or ISO 9002.</p>		<p>The generator set is available Listed to UL 2200, Stationary Engine Generator Assemblies.</p>
	<p>The Prototype Test Support (PTS) program verifies the performance integrity of the generator set design. Cummins products bearing the PTS symbol meet the prototype test requirements of NFPA 110 for Level 1 systems.</p>	<p>U.S. EPA</p>	<p>Engine certified to U.S. EPA SI Stationary Emission Regulation 40 CFR, Part 60.</p>
	<p>All low voltage models are CSA certified to product class 4215-01.</p>	<p>International Building Code</p>	<p>The generator set is certified to International Building Code (IBC) 2012.</p>

Warning: Back feed to a utility system can cause electrocution and/or property damage. Do not connect to any building's electrical system except through an approved device or after building main switch is open.

For more information contact your local Cummins distributor or visit power.cummins.com

Our energy working for you.™





Generator set data sheet

Model: **C100D6C**
 Frequency: 60 Hz
 Fuel type: **Diesel**
 KW rating: **100 standby**
 90 prime
 Emissions level: EPA Tier 3, Stationary emergency

Exhaust emission data sheet:	EDS-2029
Exhaust emission compliance sheet:	EPA-3042
Sound performance data sheet:	MSP-1303
Cooling performance data sheet:	MCP-1403
Prototype test summary data sheet:	PTS-450

Fuel consumption	Standby				Prime			
	kW (kVA)				kW (kVA)			
Ratings	100 (125)				90 (113)			
Load	1/4	1/2	3/4	Full	1/4	1/2	3/4	Full
US gph	2.80	4.80	6.90	8.90	2.40	4.30	6.40	7.70
L/hr	10.60	18.17	26.12	33.69	9.08	16.28	24.23	29.15

Engine	Standby rating	Prime rating
Engine manufacturer	Cummins Inc.	
Engine model	QSB5-G13	
Configuration	Cast iron, in-line, 4 cylinder	
Aspiration	Turbocharged and charge air cooled	
Gross engine power output, kWm (bhp)	129 (173)	113 (152)
BMEP at set rated load, kPa (psi)	1965 (285)	1696 (246)
Bore, mm (in)	107 (4.21)	
Stroke, mm (in)	124 (4.88)	
Rated speed, rpm	1800	
Piston speed, m/s (ft/min)	7.44 (1464)	
Compression ratio	17.3:1	
Lube oil capacity, L (qt)	12.2 (12.9)	
Overspeed limit, rpm	2250	

Fuel flow

Maximum fuel flow, L/hr (US gph)	133 (35.0)
Maximum fuel inlet restriction with clean filter, mm Hg (in Hg)	127 (5.0)

Air	Standby rating	Prime rating
Combustion air, m ³ /min (scfm)	9.995 (353)	10.11 (357)
Maximum air cleaner restriction with clean filter, kPa (in H ₂ O)	1.25 (5)	

Exhaust

Exhaust flow at set rated load, m ³ /min (cfm)	24.9 (878)	22.4 (790)
Exhaust temperature, °C (°F)	489 (913)	431 (808)
Maximum back pressure, kPa (in H ₂ O)	10 (40.18)	10 (40.18)
Available exhaust back pressure with CPG sound level 2 enclosure muffler, kPa (in H ₂ O)	0 (0)	1.0 (4)
Available exhaust back pressure with CPG weather enclosure muffler, kPa (in H ₂ O)	1.0 (4)	2.0 (8)

Standard set-mounted radiator cooling

Ambient design, °C (°F)	50 (122)	
Fan load, kW _m (HP)	5.22 (7)	
Coolant capacity (with radiator), L (US Gal)	16 (4.2)	
Cooling system air flow, m ³ /min (scfm)	218.04 (7700)	
Total heat rejection, MJ/min (Btu/min)	12.22 (11584)	11.33 (10736)
Maximum cooling air flow static restriction, kPa (in H ₂ O)	0.12 (0.5)	

Weight²

Unit wet weight kgs (lbs)	Refer to drawings for specific weights and dimensions
---------------------------	---

Notes:

¹ For non-standard remote installations contact your local Cummins Power Generation representative.

² Weights represent a set with standard features. See outline drawing for weights of other configurations.

Derating factors

Standby	Engine power available to 1295 m (4250 ft) and ambient temperatures up to 40° C (104° F). Above these conditions, derate at 17.5% per 300 m (1000 ft) until 1700 m (5600 ft) and then derate at 2.2% per 300 m (1000 ft). Also derate 16.1% per 10° C (18° F)
Prime	Engine power available to 1448 m (4750 ft) and ambient temperatures up to 40° C (104° F). Above these conditions, derate at 17.5% per 300 m (1000 ft) until 1700 m (5600 ft) and then derate at 2.3% per 300 m (1000 ft). Also derate 18.8% per 10° C (18° F)

Ratings definitions

Emergency standby power (ESP):	Limited-time running power (LTP):	Prime power (PRP):	Base load (continuous) power (COP):
Applicable for supplying power to varying electrical load for the duration of power interruption of a reliable utility source. Emergency Standby Power (ESP) is in accordance with ISO 8528. Fuel Stop power in accordance with ISO 3046, AS 2789, DIN 6271 and BS 5514.	Applicable for supplying power to a constant electrical load for limited hours. Limited Time Running Power (LTP) is in accordance with ISO 8528.	Applicable for supplying power to varying electrical load for unlimited hours. Prime Power (PRP) is in accordance with ISO 8528. Ten percent overload capability is available in accordance with ISO 3046, AS 2789, DIN 6271 and BS 5514.	Applicable for supplying power continuously to a constant electrical load for unlimited hours. Continuous Power (COP) is in accordance with ISO 8528, ISO 3046, AS 2789, DIN 6271 and BS 5514.

Alternator data

Standard Alternators	Single phase ²		Three phase ¹			
Maximum temperature rise above 40 °C ambient	120 °C	120 °C	120 °C	120 °C	120 °C	120 °C
Feature code	BB88-2 ³	BB90-2	B946-2	B986-2	B943-2	B952-2
Alternator data sheet number	ADS-209	ADS-207	ADS-207	ADS-207	ADS-207	ADS-207
Voltage ranges	120/240	120/240	120/208	120/240	277/480	347/600
Voltage feature code	R104-2	R104-2	R098-2	R106-2	R002-2	R114-2
Surge kW	112.4	111.6	116.1	116.1	117.5	117.5
Motor starting kVA (at 90% sustained voltage) Shunt			360	360	360	360
Motor starting kVA (at 90% sustained voltage) PMG			423	423	423	423
Full load current amps at standby rating	417	417	347	301	150	120

Alternator data

Standard Alternators	Single phase ²	Three phase ¹			
Maximum temperature rise above 40 °C ambient	105 °C	105 °C	105 °C	105 °C	105 °C
Feature code	BB91-2	BB93-2	BB94-2	BB95-2	BB92-2
Alternator data sheet number	ADS-208	ADS-208	ADS-208	ADS-207	ADS-207
Voltage ranges	120/240	120/208	120/240	277/480	347/600
Voltage feature code	R104-2	R098-2	R106-2	R002-2	R114-2
Surge kW	113.2	118.1	118.1	117.5	117.5
Motor starting kVA (at 90% sustained voltage) Shunt		422	422	360	360
Motor starting kVA (at 90% sustained voltage) PMG		497	497	423	423
Full load current amps at standby rating	417	347	301	150	120

Notes:

¹ Single phase power can be taken from a three phase generator set at up to 2/3 set rated 3-phase kW at 1.0 power factor

² Full single phase output up to full set rated 3-phase kW at 1.0 power factor

³ Reconnectable option

Formulas for calculating full load currents:

$\frac{\text{Three phase output}}{\text{Voltage} \times 1.73 \times 0.8} = \frac{\text{kW} \times 1000}{\text{Voltage} \times 1.73 \times 0.8}$	$\frac{\text{Single phase output}}{\text{Voltage}} = \frac{\text{kW} \times \text{SinglePhaseFactor} \times 1000}{\text{Voltage}}$
---	--

Warning: Back feed to a utility system can cause electrocution and/or property damage. Do not connect to any building's electrical system except through an approved device or after building main switch is open.

North America
1400 73rd Avenue N.E.
Minneapolis, MN 55432
USA

Phone 763 574 5000
 Fax 763 574 5298

Our energy working for you.™

©2018 Cummins Inc. All rights reserved.
 Cummins is a registered trademarks of Cummins Inc. PowerCommand, AmpSentry, InPower and "Our energy working for you." are trademarks of Cummins. Other company, product, or service names may be trademarks or service marks of others. Specifications are subject to change without notice.
 NAD-6336-EN (03/25) A059X437



power.cummins.com



PowerCommand®

1.1 Control System



Description

The PowerCommand control system is a microprocessor-based generator set monitoring, metering and control system designed to meet the demands of today's engine driven generator sets. The integration of all control functions into a single control system provides enhanced reliability and performance compared to conventional generator set control systems. These control systems have been designed and tested to meet the harsh environment in which gensets are typically applied.

Features

Easy to view: HMI 211RS for residential use. 128 x 64 pixel graphic LED backlight LCD.

Easy to use: Tactile buttons for generator set start/stop. Residential Standby display for convenient use.

Modbus® interface: Eliminates need for MODLON.

Progressive protective functions: Advanced Overcurrent Protection – Generator set monitoring & protection.

Digital voltage regulation: Single phase full wave SCR type regulator compatible with either shunt or PMSG systems.

Digital engine speed governing: Provides isochronous frequency regulation.

12 and 24 VDC battery operation.

Automatic mains failure: Smooth & automatic transfer and re-transfer of load from utility to generator set & vice-versa.

Exerciser clock: Runs generator set exerciser routines for dependability of operation.

Warranty and service: Backed by a comprehensive warranty and worldwide distributor service network.

Certification: Suitable for use on generator sets that are designed, manufactured, tested and certified to relevant UL, NFPA, ISO, IEC Mil Std., CE, UKCA and CSA standards.

PowerCommand Digital Generator Set Control PCC 1302



Description

The PowerCommand generator set control is suitable for use on a wide range of generator sets in non-parallel applications. The PowerCommand control is compatible with shunt or PMG excitation style. It is suitable for use with reconnectable or non-reconnectable generators, and it can be configured for any frequency, voltage and power connection from 120-600 VAC Line-to-Line.

Power for this control system is derived from the generator set starting batteries. The control functions over a voltage range from 8 VDC to 30 VDC.

Features

- 12 and 24 VDC battery operation.
- Digital voltage regulation.
- Digital engine speed governing (where applicable) - Provides isochronous frequency regulation.
- Full authority engine communications (where applicable) - Provides communication and control with the Engine Control Module (ECM).
- Common harnessing - with higher feature Cummins controls allows for easy field upgrades.
- Generator set monitoring - Monitors status of all critical engine and alternator functions.
- Digital genset metering (AC and DC).
- Genset battery monitoring system - to sense and warn against a weak battery condition.
- Engine starting - Includes relay drivers for starter, fuel shut off (FSO), glow plug/spark ignition power and switch B+ applications.
- Generator set protection - Protects engine and alternator.
- Advanced serviceability - using InPower™, a PC-based software service tool.
- Environmental protection - The control system is designed for reliable operation in harsh environments. The main control board is a fully encapsulated module that is protected from the elements.
- Exerciser function – Routine exercising of generator set.
- Supports dual fuel control.
- Automatic Mains Failure function built in generator set controller. Modbus interface - for interconnecting to customer equipment.

- Configurable inputs and outputs - Four discrete inputs and two dry contact relay outputs.
- Warranty and service - Backed by a comprehensive warranty and worldwide distributor service network.
- Certifications - Suitable for use on generator sets that are designed, manufactured, tested and certified to relevant UL, NFPA, ISO, IEC, Mil Std., CE, UKCA and CSA standards.

Base Control Functions

HMI capability

Operator adjustments - The HMI includes provisions for many set up and adjustment functions.

Generator set hardware data - Access to the control and software part number, generator set rating in kVA and generator set model number is provided from the HMI or InPower™.

Data logs - Includes engine run time, controller on time, number of start attempts.

Fault history - Provides a record of the most recent fault conditions with control hours time stamp. Up to 10 events are stored in the control non-volatile memory.

Alternator data

- Voltage (single or three phase Line-to-Line and Line-to-Neutral)
- Current (single or three phase)
- kVA (three phase and total)
- Frequency
- Engine data
- Starting battery voltage
- Engine speed
- Engine temperature
- Engine oil pressure
- Partial Full Authority Engine (FAE) data (where applicable)
- Service adjustments - The HMI includes provisions for adjustment and calibration of generator set control functions. Adjustments are protected by a password. Functions include:
 - Engine speed governor adjustments
 - Voltage regulation adjustments
 - Cycle cranking
 - Configurable fault set up
 - Configurable output set up
 - Meter calibration
 - Units of measurement

Engine control

SAE-J1939 CAN interface to full authority ECMs (where applicable) - Provides data swapping between genset and engine controller for control, metering and diagnostics.

12 VDC/24 VDC battery operations - PowerCommand will operate either on 12 VDC or 24 VDC batteries.

Isochronous governing (where applicable) - Capable of controlling engine speed within +/-0.25% for any steady state load from no load to full load. Frequency drift will not exceed +/-0.5% for a 33 °C (60 °F) change in ambient temperature over an 8 hour period.

Temperature dependent governing dynamics (with electronic governing) - Modifies the engine governing control parameters as a function of engine temperature. This allows the engine to be more responsive when warm and more stable when operating at lower temperature levels.

Remote start mode - Accepts a ground signal from remote devices to automatically start the generator set and immediately accelerate to rated speed and voltage. The remote start signal will also wake up the control from sleep mode. The control can incorporate a time delay start and stop.

Remote and local Emergency stop - The control accepts a ground signal from a local (genset mounted) or remote (facility mounted) Emergency stop switch to cause the generator set to immediately shut down. The generator set is prevented from running or cranking with the switch engaged. If in sleep mode, activation of either Emergency stop switch will wake up the control.

Sleep mode - The control includes a configurable low current draw state to minimize starting battery current draw when the genset is not operating. The control can also be configured to go into a low current state while in auto for Prime applications or applications without a battery charger.

Engine starting - The control system supports automatic engine starting. Primary and backup start disconnects are achieved by one of three methods: magnetic pickup, battery charging alternator feedback or main alternator output frequency. The control also supports configurable glow plug control when applicable.

Cycle cranking - Configurable for the number of starting cycles (1 to 7) and duration of crank and rest periods. Control includes starter protection algorithms to prevent the operator from specifying a starting sequence that might be damaging.

Time delay start and stop (cooldown) - Configurable for time delay of 0-300 seconds prior to starting after receiving a remote start signal and for time delay of 0-600 seconds prior to shut down after signal to stop in normal operation modes. Default for both time delay periods is 0 seconds.

Alternator control

The control includes an integrated line-to-line sensing voltage regulation system that is compatible with shunt or PMG excitation systems. The voltage regulation system is full wave rectified and has an SCR output for good motor starting capability. Major system features include:

Digital output voltage regulation - Capable of regulating output voltage to within +/-1.0% for any loads between no load and full load. Voltage drift will not exceed +/-1.5% for a 40 °C (104 °F) change in temperature in an eight hour period. On engine starting or sudden load acceptance, voltage is controlled to a maximum of 5% overshoot over nominal level.

The automatic voltage regulator feature can be disabled to allow the use of an external voltage regulator.

Torque-matched V/Hz overload control - The voltage roll-off set point and rate of decay (i.e. the slope of the V/Hz curve) is adjustable in the control.

Protective Functions

On operation of a protective function the control will indicate a fault by illuminating the appropriate status LED on the HMI, as well as display the fault code and fault description on the LCD. The nature of the fault and time of occurrence are logged in the control. The service manual and InPower service tool provide service keys and procedures based on the service codes provided. Protective functions include:

Battle short mode

When enabled and the battle short switch is active, the control will allow some shutdown faults to be bypassed. If a bypassed shutdown fault occurs, the fault code and description will still be annunciated, but the genset will not shutdown. This will be followed by a fail to shutdown fault. Emergency stop shutdowns and others that are critical for proper operation are not bypassed. Please refer to the Control Application Guide or Manual for list of these faults.

Configurable alarm and status inputs

The control accepts up to four alarm or status inputs (configurable contact closed to ground or open) to indicate a configurable (customer-specified) condition. The control is programmable for warning, shutdown or status indication and for labelling the input.

Emergency stop

Annunciated whenever either Emergency stop signal is received from external switch.

General engine protection

Low and high battery voltage warning - Indicates status of battery charging system (failure) by continuously monitoring battery voltage.

Weak battery warning - The control system will test the battery each time the generator set is signaled to start and indicate a warning if the battery indicates impending failure.

Fail to start (overcrank) shutdown - The control system will indicate a fault if the generator set fails to start by the completion of the engine crank sequence.

Fail to crank shutdown - Control has signaled starter to crank engine but engine does not rotate.

Cranking lockout - The control will not allow the starter to attempt to engage or to crank the engine when the engine is rotating.

Hydro mechanical fuel system engine protection

Overspeed shutdown - Default setting is 115% of nominal.

Low lube oil pressure warning/shutdown - Level is pre-set (configurable with InPower) to match the capabilities of the engine used. Control includes time delays to prevent nuisance alarms.

High lube oil temperature warning/shutdown - Level is pre-set (configurable with InPower) to match the capabilities of the engine used. Control includes time delays to prevent nuisance alarms.

High engine temperature warning/shutdown - Level is pre-set (configurable with InPower) to match the capabilities of the engine used. Control includes time delays to prevent nuisance alarms.

Low coolant temperature warning - Indicates that engine temperature may not be high enough for a 10 second start or proper load acceptance.

Sensor failure indication - Logic is provided on the base control to detect analog sensor or interconnecting wiring failures.

Full authority electronic engine protection

Engine fault detection is handled inside the engine ECM. Fault information is communicated via the SAE-J1939 data link for annunciation in the HMI

Alternator protection

High AC voltage shutdown (59) - Output voltage on any phase exceeds pre-set values. Time to trip is inversely proportional to amount above threshold. Values adjustable from 105-130% of nominal voltage, with time delay adjustable from 0.1-10 seconds. Default value is 110% for 10 seconds.

Low AC voltage shutdown (27) - Voltage on any phase has dropped below a pre-set value. Adjustable over a range of 50-95% of reference voltage, time delay 2-20 seconds. Default value is 85% for 10 seconds.

Overcurrent warning/shutdown - Implementation of the thermal damage curve with instantaneous trip level calculated based on current transformer ratio and application power rating.

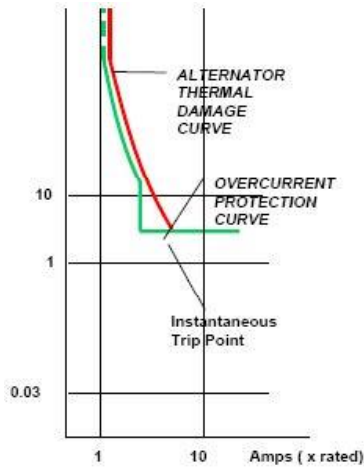

Under frequency shutdown (81 u) - Generator set output frequency cannot be maintained. Settings are adjustable from 2-10 Hz below nominal governor set point, for a 5-20 second time delay. Default: 6 Hz, 10 seconds.

Over frequency shutdown/warning (81 o) - Generator set is operating at a potentially damaging frequency level. Settings are adjustable from 2-10 Hz above nominal governor set point for a 1-20 second time delay. Default: 6 Hz, 10 seconds, enabled.

Loss of sensing voltage shutdown - Shutdown of generator set will occur on loss of voltage sensing inputs to the control.

Field overload shutdown - Uses field voltage to shutdown generator set when a field overload condition occurs.

Advanced Functions

Automatic mains failure*

The built in AMF feature provides the automatic transfer and re-transfer of the load from utility to generator set and vice-versa.

- Automatically starts-stops the generator set in the event of utility failure.
- Annunciates faults.

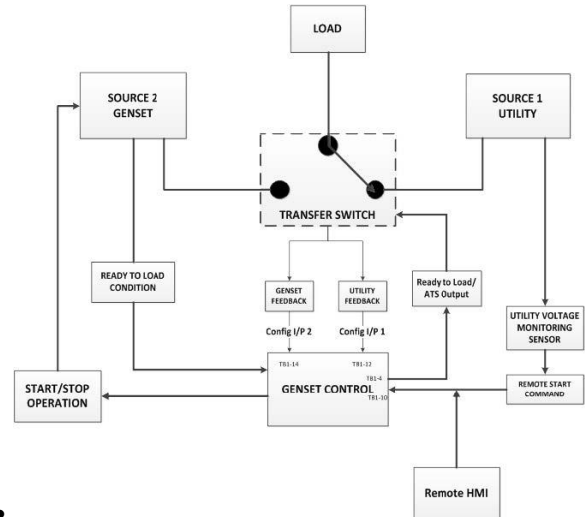

- * A utility voltage monitoring sensor (as shown in the AMF diagram above) must be connected in order to use the AMF feature on the 1302 control. Use Schneider Electric Relay RSB1A120U7 and Socket RSZE1S35M.

Exerciser clock

The exerciser clock runs the generator set exerciser routines for dependability of operation.

Field Control Interface

Input signals to the base control include:

- Remote start
- Local and Emergency stop
- Configurable inputs: Control includes (4) input signals from customer discrete devices that are configurable for warning, shutdown or status indication, as well as message displayed.

Output signals from the PowerCommand control include:

- Configurable relay outputs: Control includes (2) relay output contacts rated at 2 A. These outputs can be configured to activate on any control warning or shutdown fault as well as ready to load, not in auto, common alarm, common warning and common shutdown.
- Ready to load (generator set running) signal: Operates when the generator set has reached 90% of rated speed and voltage and latches until generator set is switched to off or idle mode.

PowerCommand Human Machine Interface HMI211



Description

This control system includes an intuitive operator interface panel that allows for complete genset control as well as system metering, fault annunciation, configuration and diagnostics. The interface includes five generator set status LED lamps with both internationally accepted symbols and English text to comply with customer needs. The interface also includes an LED backlit LCD display with tactile feel soft-switches for easy operation and screen navigation. It is configurable for units of measurement and has adjustable screen contrast and brightness.

The *run/off/auto* switch function is integrated into the interface panel.

All data on the control can be viewed by scrolling through screens with the navigation keys. The control displays the current active fault and a time-ordered history of the five previous faults.

Features

- LED indicating lamps:
 - Remote start
 - Not in auto
 - Shutdown
 - Warning
 - Auto
 - Run
- 128 x 64 pixels graphic LED backlight LCD.
- Four tactile feel membrane switches for LCD defined operation. The functions of these switches are defined dynamically on the LCD.
- Two tactile feel membrane switches dedicated for off and back.
- Allows for complete genset control setup.
- Certifications: Suitable for use on generator sets that are designed, manufactured, tested and certified to relevant UL, NFPA, ISO, IEC, Mil Std., CE, UKCA and CSA standards.
- HMI 211RS provides convenience for residential use.

Communications Connections

PC tool interface - This RS-485 communication port allows the HMI to communicate with a personal computer running InPower.

This RS-485 communication port allows the HMI to communicate with the main control board.

Mechanical Drawing

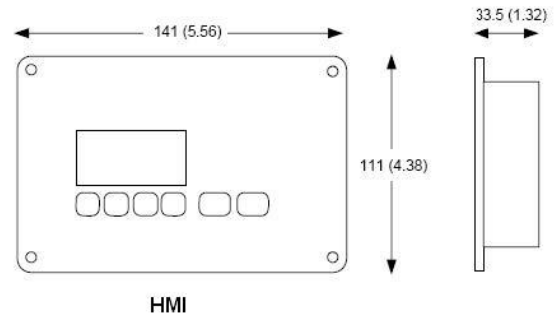

Dimensions: mm (inches)

Software

InPower (beyond 6.0 version) is a PC-based software service tool that is designed to directly communicate to PowerCommand generator sets and transfer switches, to facilitate service and monitoring of these products.

Environment

The control is designed for proper operation without recalibration in ambient temperatures from -40 °C (-40 °F) to +70 °C (158 °F), and for storage from -55 °C (-67 °F) to +80 °C (176 °F). Control will operate with humidity up to 95%, non-condensing.

The HMI is designed for proper operation in ambient temperatures from -40 °C* (-40 °F) to +70 °C (158 °F), and for storage from -40 °C* (-40 °F) to +80 °C (176 °F).

The control board is fully encapsulated to provide superior resistance to dust and moisture. Display panel has a single membrane surface, which is impervious to effects of dust, moisture, oil and exhaust fumes. This panel uses a sealed membrane to provide long reliable service life in harsh environments.

The control system is specifically designed and tested for resistance to RFI/EMI and to resist effects of vibration to provide a long reliable life when mounted on a generator set. The control includes transient voltage surge suppression to provide compliance to referenced standards.

* Heater accessory (pn: A040H853) is available for enhanced operation below -20 °C

Certifications

PowerCommand meets or exceeds the requirements of the following codes and standards:

- NFPA 110 for level 1 and 2 systems.
- ISO 8528-4: 1993 compliance, controls and switchgear.
- CE and UKCA marking: The control system is suitable for use on generator sets to be CE and UKCA-marked.
- EN 50081-1,2 residential/light industrial emissions or industrial emissions.
- EN 50082-1,2 residential/light industrial or industrial susceptibility.
- ISO 7637-2, level 2: DC supply surge voltage test.
- Mil Std. 202C, Method 101 and ASTM B117: Salt fog test.
- PowerCommand control systems and generator sets are designed and manufactured in ISO 9001 certified facilities.
- UL 6200 recognized and suitable for use on UL 2200 Listed generator sets.
- CSA C282-M1999 compliance.
- CSA 22.2 No. 14 M91 industrial controls.

Warranty

All components and subsystems are covered by an express limited one year warranty. Other optional and extended factory warranties and local distributor maintenance agreements are available

Accessories

1301-1302 Upgrade Kit (HM)	0541-1431
PowerCommand 500 (LAN)	A040X126
Remote HMI 211	0541-1394
Remote HMI 211RS	A046K103
I/O Expansion (Aux 101)	0541-1291
HMI Heater Accessory Kit	A040H853

Parts Ordering Information

1302 Control Board	0327-1617-02
1302 control Board – Arrow	A043W505
Aux 104 (Governor Control)	0327-1507
HMI 211 Without Heater	0300-6014
HMI 211 with Heater	A026G237

Additional Resources

Resource	Where to find
1302 Service Manual	QSOL
Accessories Catalog	cumminspower.com
Additional Controls Information	PowerSuite Library



For more information contact your local Cummins distributor or visit power.cummins.com

Our energy working for you.™





Alternator Data Sheet

Frame Size: UC3D

(CGT Frame Name: UCI274D)

Characteristics			No of Bearings:		1-bearing		2-bearing				
Weights:	Stator assembly:		8521 lb	3865 kg	8521 lb	3865 kg					
	Rotor assembly:		4392 lb	1992 kg	4246 lb	1926 kg					
	Complete assembly:		12912 lb	5857 kg	12767 lb	5791 kg					
Maximum speed:	2250 rpm										
Excitation current:	Full load: Wdg 12: 3.6; Wdg 13: 3.6; Wdg 19: 3.14										
	No load: Wdg 12: 0.86; Wdg 13: 0.86; Wdg 19: 0.86										
Insulation system:	Class H throughout										
3 ∅ Ratings	(0.8 power factor)		60 Hz (winding no)								
			<u>190/380</u>	<u>200/400</u>	<u>208/416</u>	<u>600</u>	<u>190/380</u>	<u>200/400</u>	<u>220/440</u>	<u>230/460</u>	<u>240/480</u>
163° C rise ratings	@ 27° C	kW	114	114	114	127	100	114	120	120	127
		kVA	142.5	142.5	142.5	158.8	125	142.5	150	150	158.8
150° C rise ratings	@ 40° C	kW	110	110	110	124	98.4	110	116	116	125
		kVA	137.5	137.5	137.5	155	123	137.5	145	145	156.3
125° C rise ratings	@ 40° C	kW	105	105	105	117	96	105	110	110	117
		kVA	131.3	131.3	131.3	146.3	120	131.3	137.5	137.5	146.3
105° C rise ratings	@ 40° C	kW	96	96	96	105	88	96	100	100	105
		kVA	120	120	120	131.3	110	120	125	125	131.3
80° C rise ratings	@ 40° C	kW	80	80	80	88	72	80	87	87	88
		kVA	100	100	100	110	90	100	108.8	108.8	110
3 ∅ Reactances			<u>190/380</u>	<u>200/400</u>	<u>208/416</u>	<u>600</u>	<u>190/380</u>	<u>208/416</u>	<u>220/440</u>	<u>230/460</u>	<u>240/480</u>
(Based on full load at 125° C rise rating)			(14)	(14)	(14)	(17)	(311)	(311)	(311)	(311)	(311)
Synchronous			3.08	2.79	2.58	2.02	2.38	2.52	2.36	2.16	2.11
Transient			0.25	0.23	0.21	0.17	0.17	0.21	0.20	0.18	0.17
Subtransient			0.17	0.16	0.14	0.11	0.16	0.15	0.14	0.13	0.12
Negative sequence			0.21	0.19	0.18	0.13	0.11	0.17	0.16	0.15	0.14
Zero sequence			0.12	0.11	0.10	0.08	0.08	0.10	0.09	0.09	0.08
3 ∅ Motor starting			<u>190/380</u>	<u>200/400</u>	<u>208/416</u>	<u>600</u>	<u>190/380</u>	<u>200/400</u>	<u>220/440</u>	<u>230/460</u>	<u>240/480</u>
Maximum kVA (90% sustained voltage)			(14)	(14)	(14)	(17)	(311)	(311)	(311)	(311)	(311)
(Shunt)			360	360	360	360	360	360	360	360	360
(PMG)			423	423	423	423	423	423	423	423	423
Time constants	(sec)		<u>190/380</u>	<u>200/400</u>	<u>208/416</u>	<u>600</u>	<u>190/380</u>	<u>200/400</u>	<u>220/440</u>	<u>230/460</u>	<u>240/480</u>
			(14)	(14)	(14)	(17)	(311)	(311)	(311)	(311)	(311)
Transient			0.03	0.03	0.03	0.03	0.031	0.031	0.031	0.031	0.031
Subtransient			0.01	0.01	0.01	0.01	0.01	0.01	0.01	0.01	0.01
Open circuit			0.82	0.82	0.82	0.82	0.85	0.85	0.85	0.85	0.85
DC			0.007	0.007	0.007	0.007	0.0073	0.0073	0.0073	0.0073	0.0073
Windings	(@22° C)		<u>190/380</u>	<u>200/400</u>	<u>208/416</u>	<u>600</u>	<u>190/380</u>	<u>200/400</u>	<u>220/440</u>	<u>230/460</u>	<u>240/480</u>
			(14)	(14)	(14)	(17)	(311)	(311)	(311)	(311)	(311)
Stator resistance	(L-L Ohms)		0.546	0.546	0.546	0.103	0.088	0.088	0.088	0.088	0.088
Rotor resistance	(Ohms)		1.26	1.26	1.26	1.26	1.26	1.26	1.26	1.26	1.26
Number of leads			12	12	12	12	12	12	12	12	12



Alternator Data Sheet

Frame Size: UC3D

(CGT Frame Name: UCI274D)

**50
Hz**

Winding 311
THREE PHASE EFFICIENCY CURVES

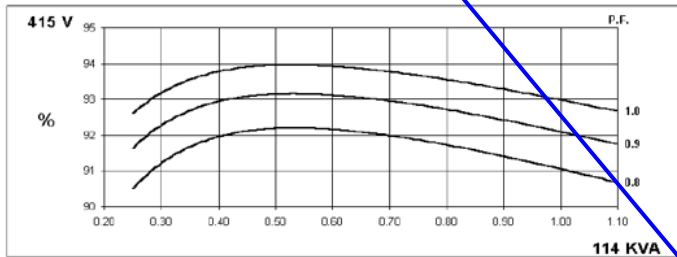
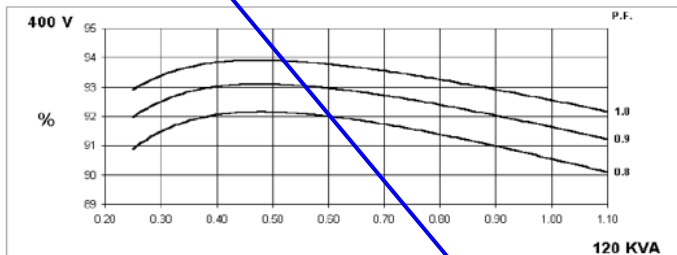
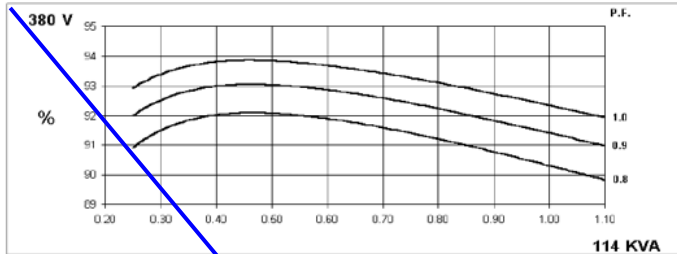

**60
Hz**

Winding 311
THREE PHASE EFFICIENCY CURVES

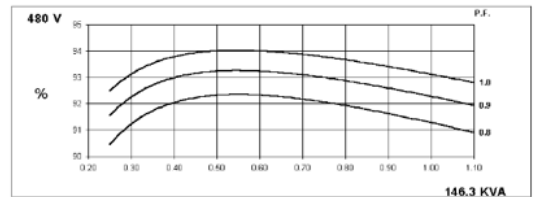
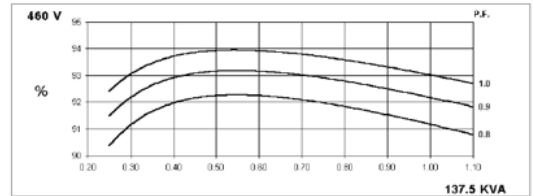
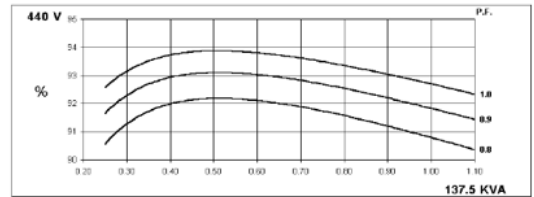
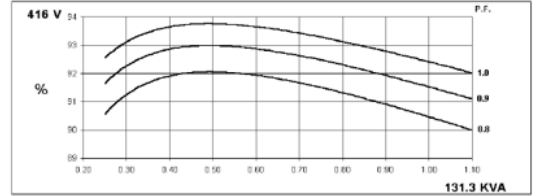



Alternator Data Sheet

Frame Size: UC3D

(CGT Frame Name: UCI274D)

Winding 311

Locked Rotor Motor Starting Curve

50
Hz

MX

SX

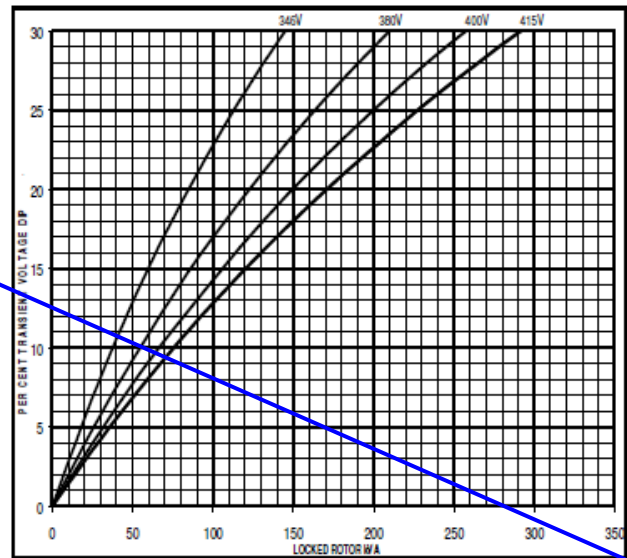
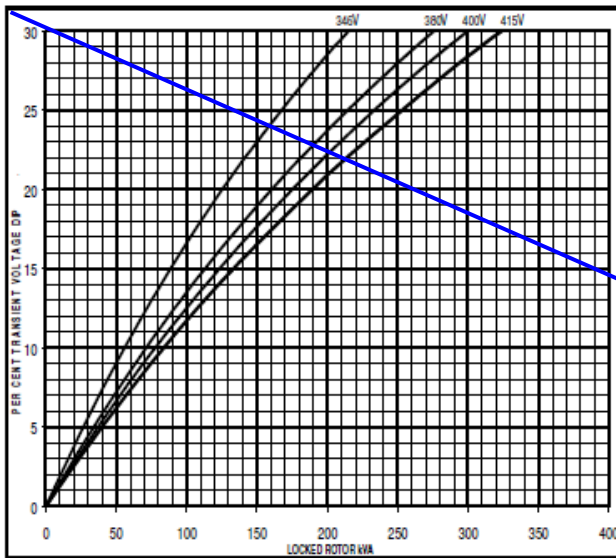

60
Hz

MX

SX

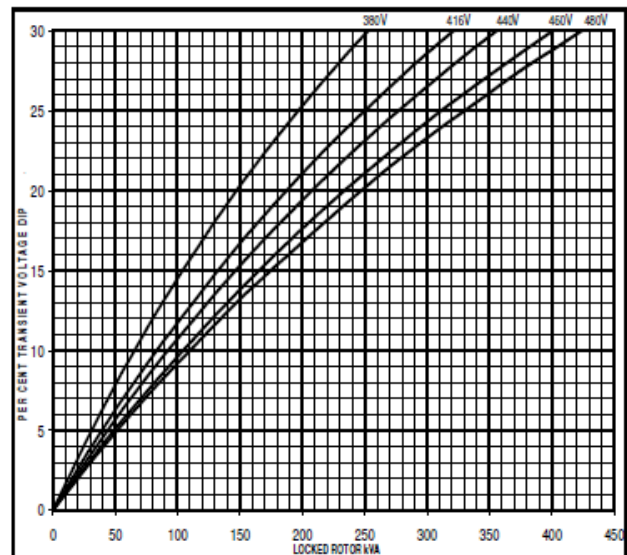
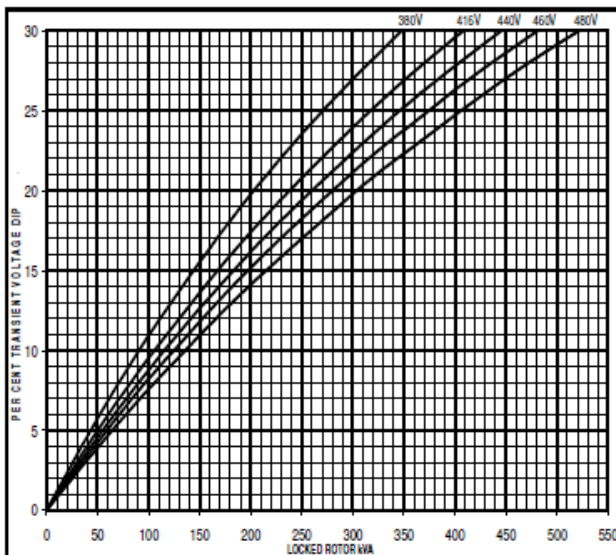



Alternator Data Sheet

Frame Size: UC3D

(CGT Frame Name: UCI274D)

Winding 311

Three-phase Short Circuit Decrement Curve. No-load Excitation at Rated Speed
Based on star (wye) connection.

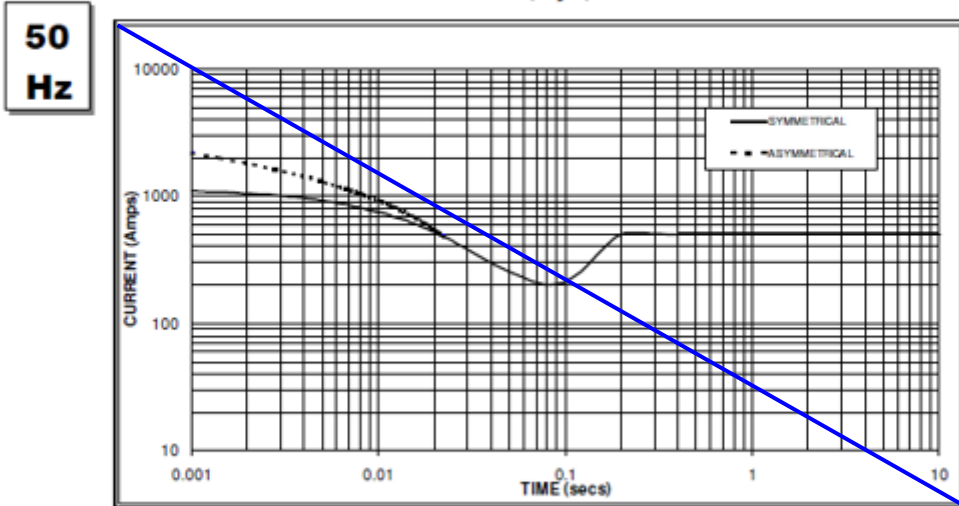

Sustained Short Circuit = 500 Amps

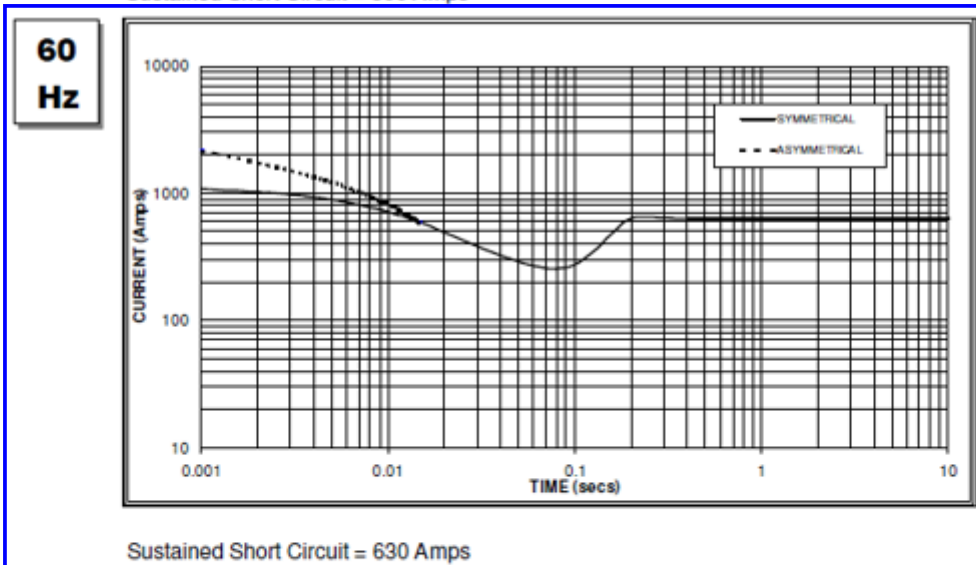

Sustained Short Circuit = 630 Amps

Note 1

The following multiplication factors should be used to adjust the values from curve between time 0.001 seconds and the minimum current point in respect of nominal operating voltage :

50Hz		60Hz	
Voltage	Factor	Voltage	Factor
380v	X 1.00	416v	X 1.00
400v	X 1.07	440v	X 1.06
415v	X 1.12	460v	X 1.12

Note 2

The following multiplication factor should be used to convert the values calculated in accordance with NOTE 1 to those applicable to the various types of short circuit :

	3-phase	2-phase L-L	1-phase L-N
Instantaneous	x 1.00	x 0.87	x 1.30
Minimum	x 1.00	x 1.80	x 3.20
Sustained	x 1.00	x 1.50	x 2.50
Max. sustained duration	10 sec.	5 sec.	2 sec.



Sound data

C100D6C

QSB5-G13 60Hz Diesel Generator Set

Sound Pressure Level @ 7 meters, dB(A)

See notes 2,5,7-11 listed below

Configuration	Exhaust system	Position (Note 1)								8 Position Average
		1	2	3	4	5	6	7	8	
Standard – Unhoused	Infinite Exhaust	78	80.3	80.6	82.3	78.7	81.7	81.7	80.6	80.7
F216-2 Weather Protective Aluminium	Mounted	80.1	82.1	80.3	82.9	81.1	82.4	81.2	81.5	81.5
F231-2 Sound Attenuated Level 1, Aluminium	Mounted	78.8	75.6	71.6	72.8	72.5	73.2	72.5	75.5	74.7
F217-2 Sound Attenuated Level 2, Aluminium	Mounted	72.6	72.9	69.7	71	70.9	71.2	71.7	71.8	71.6

Sound Power Level, dB(A)

See notes 2-4, 7 and 8 listed below

Configuration		Octave Band Center Frequency (Hz)										Overall Sound Power Level
		31.5	63	125	250	500	1000	2000	4000	8000	16000	
Standard – Unhoused	Infinite Exhaust	54.3	79.2	89.0	92.1	100.7	102.3	101.8	98.2	94.8	90.6	107.6
F216-2 Weather Protective Aluminium	Mounted	56.1	89.2	99.2	99.8	102.8	103.7	101.7	99.7	95.3	85.8	109.5
F231-2 Sound Attenuated Level 1, Aluminium	Mounted	58.2	86.0	88.8	91.2	95.5	97.5	95.5	92.7	89.4	82.1	102.6
F217-2 Sound Attenuated Level 2, Aluminium	Mounted	57.4	86.1	88.0	89.7	93.1	92.9	90.4	87.8	84.2	74.8	99.0

Exhaust Sound Power Level, dB(A)

See notes 4,6 and 9 listed below

Open Exhaust (No Muffler) @ Rated Load	Octave Band Center Frequency (Hz)									Overall Sound Power Level
	31.5	63	125	250	500	1000	2000	4000	8000	
	57	84	99	105	112	113	116	116	113	122

Note:

1. Sound pressure levels at 1 meter are measured per the requirements of ISO 3744, ISO 8528-10, ANSI S1.13, ANSI S12.1 and European Communities Directive 2000/14/EC as applicable. The microphone measurement locations are 1 meter from a reference parallelepiped just enclosing the generator set (enclosed or unenclosed).
2. Seven-meter measurement location 1 is 7 meters (23 feet) from the generator (alternator) end of the generator set, and the locations proceed counter clockwise around the generator set at 45° angles at a height of 1.2 meters (48 inches) above the ground surface.
3. Sound Power Levels are calculated according to ISO 3744, ISO 8528-10, and or CE (European Union) requirements.
4. Exhaust Sound Levels are measured and calculated per ISO 6798, Annex A.
5. Reference Sound Pressure Level is 20 µPa.
6. Reference Sound Power Level is 1 pW (10-12 Watt).
7. Sound data for remote-cooled generator sets are based on rated loads without cooling fan noise.
8. Sound data for the generator set with infinite exhaust do not include the exhaust noise contribution.
9. Sound levels are subject to instrumentation, measurement, installation, and manufacturing variability



Sound data

C100D6C

QSB5-G13 60Hz

Diesel Generator Set

10. Unhoused/Open configuration generator sets refers to generator sets with no sound enclosures of any kind
11. Housed/Enclosed/Closed/Canopy configuration generator sets refer to generator sets that have noise reduction sound enclosures installed over the generator set and usually integrally attached to the skid base/base frame/fuel container base of the generator set.



High ambient air temperature radiator cooling system

	Fuel type	Duty	Rating (kW)	Max cooling @ air flow static restriction, unhooded (inches water/mm water)					Housed in free air, no air discharge restriction		
				0.0/0.0	0.25/6.4	0.5/12.7	0.75/19.1	1.0/25.4	F231	F217	F216
				Maximum allowable ambient temperature, degree C							
60 Hz	Diesel	Standby	100	50	50	50	50	N/A	50	50	50
		Prime	90	50	50	50	50	N/A	50	50	50

Notes:

1. Data shown are anticipated cooling performance for typical generator set.
2. Cooling data is based on 1000 ft (305 m) site test location.
3. Generator set power output may need to be reduced at high ambient conditions. Refer generator set data sheet for derate schedules.
4. Cooling performance may be reduced due to several factors including but not limited to: Incorrect installation, improper operation, fouling of the cooling system, and other site installation variables.



2026 EPA Tier 3 Exhaust Emission Compliance Statement

C100D6C

Stationary Emergency 60 Hz Diesel Generator Set

Compliance Information:

The engine used in this generator set complies with Tier 3 emissions limit of U.S. EPA New Source Performance Standards for stationary emergency engines under the provisions of 40 CFR 60 Subpart IIII.

Engine Manufacturer:	Cummins Inc.
EPA Certificate Number:	TCEXL0275AAK-045
Effective Date:	11/24/2025
Date Issued:	11/24/2025
EPA Engine Family (Cummins Emissions Family):	TCEXL0275AAK

Engine Information:

Model:	QSB5-G13	Bore:	4.21 in. (106.9 mm)
Engine Nameplate HP:	173	Stroke:	4.88 in. (123.9 mm)
Type:	4 cycle, in-line, 4 cylinder	Displacement:	272 cu. in. (4.45 liters)
Diesel Aspiration:	Turbocharged	Compression Ratio:	17.3:1
Emission Control Device:		Exhaust Stack Diameter:	4 in. (102 mm)

Diesel Fuel Emission Limits

D2 Cycle Exhaust Emissions

	Grams per BHP-hr			Grams per kWm-hr		
	<u>NO_x + NMHC</u>	<u>CO</u>	<u>PM</u>	<u>NO_x + NMHC</u>	<u>CO</u>	<u>PM</u>
EPA Emissions Limit	3.0	2.6	0.15	4.0	3.5	0.20

Test methods: EPA emissions recorded per 40 CFR Part 60, 89, 1039, 1065 and weighted at load points prescribed in the regulations for constant speed engines.

Diesel fuel specifications: Cetane number: 40-50, Reference: ASTM D975 No. 2-D, 300-500 ppm Sulphur

Reference conditions: Air Inlet Temperature: 25 °C (77 °F), Fuel Inlet Temperature: 40 °C (104 °F). Barometric Pressure: 100 kPa (29.53 in Hg), Humidity: 10.7 g/kg (75 grains H2O/lb) of dry air; required for NOx correction, Restrictions: Intake Restriction set to a maximum allowable limit for clean filter; Exhaust Back Pressure set to a maximum allowable limit.

Tests conducted using alternate test methods, instrumentation, fuel or reference conditions can yield different results. Engine operation with excessive air intake or exhaust restriction beyond published maximum limits, or with improper maintenance, may result in elevated emission levels.



Exhaust Emission Data Sheet

C100D6C

60 Hz Diesel Generator Set

Engine Information:

Model:	Cummins QSB5-G13	Bore:	4.21 in. (106.9 mm)
Type:	4 cycle, in-line, 4 cylinder diesel	Stroke:	4.88 in. (123.9 mm)
Aspiration:	Turbocharged	Displacement:	272 cu. in. (4.45 liters)
Compression Ratio:	17.3:1	Exhaust Stack Diameter:	3.5 in (88.9 mm)
Emission Control Device:	Turbocharged and charge air-cooled		

<u>Performance Data</u>	<u>1/4 Standby</u>	<u>1/2 Standby</u>	<u>3/4 Standby</u>	<u>Full Standby</u>	<u>Full Prime</u>
BHP @ 1800 RPM (60 Hz)	44	88	132	176	152
Fuel Consumption (gal/Hr)	2.8	4.8	6.9	8.9	7.7
Exhaust Gas Flow (CFM)	388	606	763	878	790
Exhaust Gas Temperature (°F)	496	597	764	913	808
Exhaust Emission Data					
HC (Total Unburned Hydrocarbons)	0.10	0.06	0.03	0.03	0.02
NOx (Oxides of Nitrogen as NO ₂)	2.31	2.22	2.73	3.84	3.70
CO (Carbon Monoxide)	0.76	0.52	0.36	0.52	0.30
PM (Particulate Matter)	0.16	0.23	0.04	0.05	0.03
Smoke (Bosch)	0.76	0.84	0.44	0.65	0.29

All values (except smoke) are cited: g/BHP-hr

Test Conditions

Data is representative of steady-state engine speed (± 25 RPM) at designated genset loads. Pressures, temperatures, and emission rates were stabilized.

Fuel Specification:	ASTM D975 No. 2-D diesel fuel with 0.03-0.05% sulfur content (by weight), and 40-48 cetane number.
Fuel Temperature:	99 \pm 9 °F (at fuel pump inlet)
Intake Air Temperature:	77 \pm 9 °F
Barometric Pressure:	29.6 \pm 1 in. Hg
Humidity:	NOx measurement corrected to 75 grains H ₂ O/lb dry air
Reference Standard:	ISO 8178

The NOx, HC, CO and PM emission data tabulated here are representative of test data taken from a single engine under the test conditions shown above. Data for the other components are estimated. These data are subjected to instrumentation and engine-to-engine variability. Field emission test data are not guaranteed to these levels. Actual field test results may vary due to test site conditions, installation, fuel specification, test procedures and instrumentation. Engine operation with excessive air intake or exhaust restriction beyond published maximum limits, or with improper maintenance, may result in elevated emission levels.



Prototype Test Support (PTS)

60 Hz test summary



<u>Generator set models</u>		<u>Representative prototype</u>	
C50D6C	C80D6C	Model:	C100D6C
C60D6C	C100D6C	Alternator:	UC27 D
		Engine:	QSB5-G5

The following summarizes prototype testing conducted on the designated representative prototype of the specified models. This testing is conducted to verify the complete generator set electrical and mechanical design integrity. Prototype testing is conducted only on generator sets not sold as new equipment.

Maximum surge power: 117.5 kW
 The generator set was evaluated to determine the stated maximum surge power.

Maximum motor starting: 146.3 kVA
 The generator set was tested to simulate motor starting by applying the specified kVA load at low lagging power factor (0.4 or lower). With this load applied, the generator set recovered to a minimum of 90% rated voltage.

Alternator temperature rise:
 The highest rated temperature rise (120 °C) test results are reported as follows to verify that worst case temperature rises do not exceed allowable NEMA MG1 limits for class H insulation. Tests were conducted per IEEE 115, rise by resistance and embedded detector, with the rated voltages. Only the highest temperatures are reported.

<u>Location</u>	<u>Maximum rise (°C)</u>
Alternator stator	N/A
Alternator rotor	N/A
Exciter stator	N/A
Exciter rotor	N/A

Torsional analysis and testing:
 The generator set was tested to verify that the design is not subjected to harmful torsional stresses. A spectrum analysis of the transducer output was conducted.

Cooling system: 50 °C ambient
 0.5 in. H₂O restriction

The cooling system was tested to determine ambient temperature and static restriction capabilities. The test was performed at full rated load in elevated ambient temperature under static restriction conditions.

Durability:
 The C100D6C generator set was subjected to a minimum 500 hour endurance test operating at variable load up to the Standby rating based upon MIL-STD-705 to verify structural soundness and durability of the design.

Electrical and mechanical strength:
 The generator set was tested to several single phase and three phase faults to verify that the generator can safely withstand the forces associated with short circuit conditions. The generator set was capable of producing full rated output at the conclusion of the testing.

Steady state performance:
 The generator set was tested to verify if the steady state operating performance was within the specified maximum limits.

Voltage regulation:	± 1%
Random voltage variation:	± 1%
Frequency regulation:	± Isochronous
Random frequency variation:	± 0.5%

Transient performance:
 The generator set was tested to verify single step loading capability as required by NFPA 110 and verify acceptable voltage and frequency response on load addition or rejection. The following results were recorded at 1.0 power factor:

Full load acceptance:

Voltage dip:	28%
Recovery time:	1.3 seconds
Frequency dip:	9.1%
Recovery time:	2.6 seconds

Full load rejection:

Voltage rise:	20.2%
Recovery time:	0.6 seconds
Frequency rise:	7.0%
Recovery time:	1.7 seconds

Harmonic analysis:
 (per MIL-STD-705B, method 601.4)

<u>Harmonic</u>	<u>Line to Line</u>		<u>Line to Neutral</u>	
	<u>No load</u>	<u>Full load</u>	<u>No load</u>	<u>Full load</u>
3	0.04	0.15	0.15	0.15
5	0.2	0.2	0.2	0.2
7	0.6	0.6	0.6	0.6
9	0.02	0.04	0.04	0.04
11	0.52	0.52	0.52	0.52
13	0.26	0.26	0.26	0.26
15	0.0	0.0	0.0	0.0

SECTION 3

Generator Accessories



Product data sheet

Specifications

SQUARE D

Green Premium™



Circuit breaker, PowerPacT J, unit mount, Micrologic 3.2S, 250A, 3 pole, 14kA, 600VAC

JDL36250CU33X

Main

Range	PowerPact
Product name	PowerPact J
Product or Component Type	Circuit breaker
Device application	Distribution

Complementary

Line Rated Current	250 A
Number of Poles	3P
Control type	Toggle
Breaking capacity code	D
Breaking capacity	25 kA 240 V AC 50/60 Hz UL 489 18 kA 480 V AC 50/60 Hz 14 kA 600 V AC 50/60 Hz 20 kA 250 V DC
[Ue] rated operational voltage	600 V AC 50/60 Hz IEC 60947-3
Network Frequency	50/60 Hz
[Ics] rated service breaking capacity	25 kA 220/240 V AC 50/60 Hz IEC 60947-2 18 kA 380/440/415 V AC 50/60 Hz IEC 60947-2 14 kA 500/525 V AC 50/60 Hz IEC 60947-2 20 kA 250 V DC IEC 60947-2 20 kA 500 V DC IEC 60947-2
[Uimp] rated impulse withstand voltage	8 kV IEC 60947-2
Trip unit technology	Electronic, standard, Micrologic 3.2 S, LSI
[Ui] rated insulation voltage	750 V IEC 60947-2
Trip unit name	Micrologic 3.2 S
Protection Type	Overload protection Short-circuit protection
Suitability for isolation	Yes IEC 60947-2
Utilisation category	Category A
AWG gauge	Please see CB outline drawing for lug and termination details
Local signalling	Ready 1 LED green) Alarm 1 LED 90 % I _r orange)

Alarm 1 LED 105 % I_r red)
Switched off (OFF) 1 trip indicator green)

Mounting mode	Unit mount lug)
Mounting Support	Lug
Electrical connection	Lugs line Lugs load
Terminal identifier	Please see CB outline drawing for lug and termination details
Long time pick-up adjustment range	0.25...1 x I _n
Tightening torque	221.27 lbf.in (25 N.m) 0.15...0.29 in ² (95...185 mm ²) (AWG 3/0...350 kcmil)
Number of slots	2 auxiliary switch OF plug-in) 1 alarm switch SD plug-in) 1 overcurrent trip switch SDE plug-in) 1 voltage release MN or MX plug-in)
Power wire stripping length	0.98 in (25 mm)
Height	7.52 in (191 mm)
Width	4.09 in (104 mm)
Depth	3.39 in (86 mm)
Net weight	5.29 lb(US) (2.4 kg)
Communication interface	Modbus Ethernet

Environment

Quality labels	CE
Standards	UL CSA NEMA NOM-003-SCFI-2000 IEC 60947-2
Product certifications	UL CSA NOM
IP degree of protection	Front cover IP40
Pollution degree	3 IEC 60947-1
Ambient Air Temperature for Operation	28...158 °F (-2...70 °C)
Ambient Air Temperature for Storage	-58...185 °F (-50...85 °C)
Operating altitude	< 6561.68 ft (2000 m) without derating 5000 m with derating

Ordering and shipping details

Category	01107-H/J ELEC TRIP UNIT MOUNT BREAKER/SW
Discount Schedule	DE2
GTIN	785901952282
Nbr. of units in pkg.	1
Package weight(Lbs)	5.00 lb(US) (2.268 kg)
Returnability	Yes
Country of origin	US

Packing Units

Unit Type of Package 1	PCE
Package 1 Height	5.13 in (13.018 cm)

Package 1 width	7.25 in (18.415 cm)
Package 1 Length	8.44 in (21.433 cm)

Offer Sustainability

Sustainable offer status	Green Premium product
California proposition 65	WARNING: This product can expose you to chemicals including: DINP, which is known to the State of California to cause cancer, and DIDP, which is known to the State of California to cause birth defects or other reproductive harm. For more information go to www.P65Warnings.ca.gov
REACH Regulation	REACH Declaration
EU RoHS Directive	Compliant EU RoHS Declaration
Mercury free	Yes
RoHS exemption information	Yes
China RoHS Regulation	China RoHS declaration Product out of China RoHS scope. Substance declaration for your information.
Environmental Disclosure	Product Environmental Profile
Circularity Profile	End of Life Information
PVC free	Yes

Dimensions

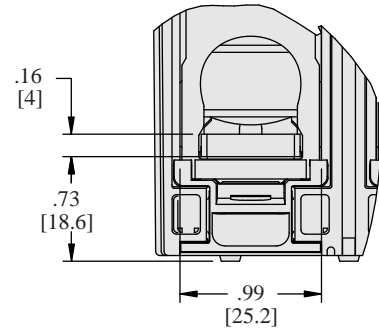
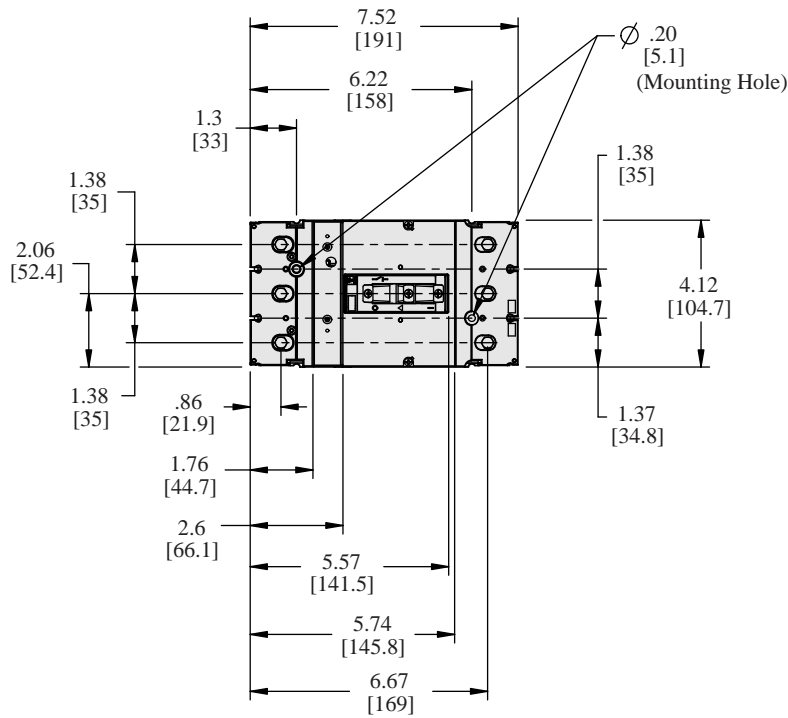

DETAIL A

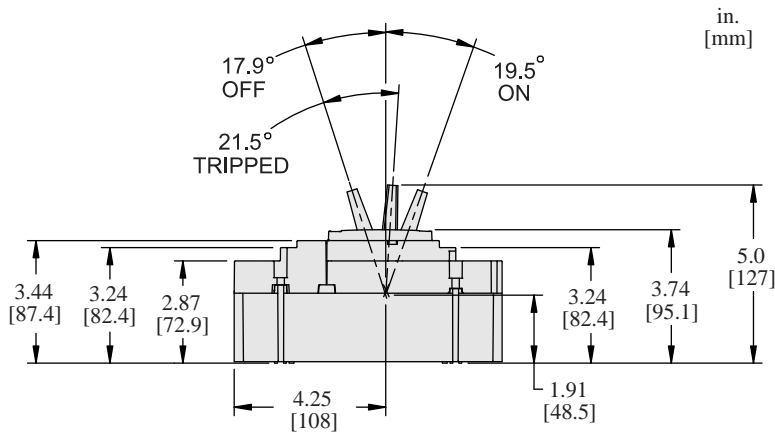

in.
[mm]

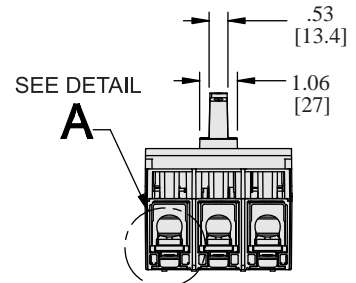

SEE DETAIL

A

Please see CB outline drawing
for lug and termination details

PowerPact™ H-, J-, and L-Frame Circuit Breakers Trip Units

Micrologic™ 3 Trip Units

Micrologic 3 trip units can be used on PowerPact H-, J-, and L-Frame circuit breakers with performance levels D/G/J/L.

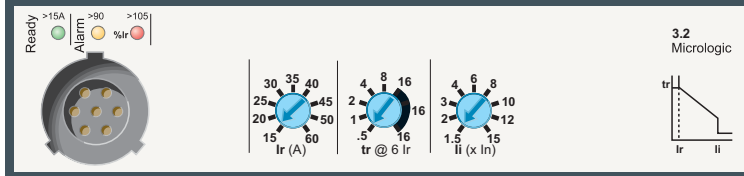

They provide:

- standard protection of distribution cables
- indication of:
 - overloads (using LEDs)
 - overload tripping (using the SDx relay module).

Circuit breakers equipped with Micrologic 3 trip units can be used to protect distribution systems supplied by transformers.

Protection

Settings are made using the adjustment rotary switches.

Overloads: Long time protection (I_r)

Inverse time protection against overloads with an adjustable current pick-up I_r set using a rotary switch and an adjustable time delay t_r .

Neutral protection

- On 3-pole L-frame circuit breakers, neutral protection is not possible.
- On four-pole L-frame circuit breakers, neutral protection may be set using a three-position switch:
 - switch position 4P 3D: neutral unprotected
 - switch position 4P 3D + N/2: neutral protection at half the value of the phase pick-up, ($0.5 \times I_r$)
 - switch position 4P 4D: neutral fully protected at I_r

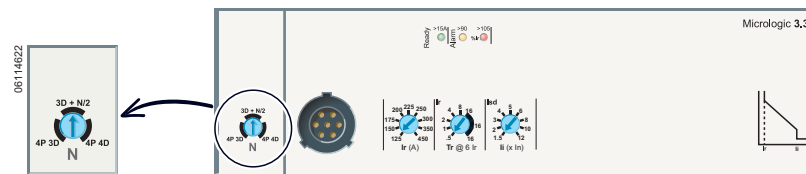

Indicators

Front indicators

- The green “Ready” LED blinks slowly when the electronic trip unit is ready to provide protection. It indicates the trip unit is operating correctly.
- Orange overload pre-alarm LED: steady on when $I > 90\% I_r$
- Red overload LED: steady on when $I > 105\% I_r$

Remote indicators

An overload trip signal can be remotely checked by installing an SDx relay module inside the circuit breaker. This module receives the signal from the Micrologic electronic trip unit through an optical link and makes it available on the terminal block. The signal is cleared when the circuit breaker is reclosed. See page 94.

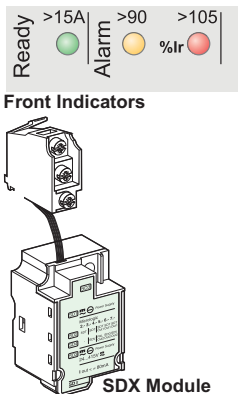

PowerPact™ H-, J-, and L-Frame Circuit Breakers Trip Units

Table 50: Micrologic™ 3 Trip Unit

Ratings	I_n at 104°F (40°C) ¹		60 A	100 A	150 A	250 A	400 A	600 A
Circuit Breaker	H-frame		X	X	X			
	J-frame					X		
	L-frame					X	X	X

Micrologic 3.2 / 3.3 trip units

L Long-time protection

	I_r		Value depending on sensor rating (I_n) and setting on rotary switch									
	Pick-Up (A) Tripping between 1.05 and 1.20 I_r	$I_n = 60$ A	$I_r =$	15	20	25	30	35	40	45	50	60
$I_n = 100$ A		$I_r =$	35	40	45	50	60	70	80	90	100	
$I_n = 150$ A		$I_r =$	50	60	70	80	90	100	110	125	150	
$I_n = 250$ A		$I_r =$	70	80	100	125	150	175	200	225	250	
$I_n = 400$ A		$I_r =$	125	150	175	200	225	250	300	350	400	
$I_n = 600$ A		$I_r =$	200	225	250	300	350	400	450	500	600	

Time Delay (s) Accuracy 0 to -20%	t_r		0.5	1	2	4	8	16	
		$1.5 \times I_r$		15	25	50	100	200	400
		$6 \times I_r$		0.5	1	2	4	8	16
$7.2 \times I_r$			0.35	0.7	1.4	2.8	5.5	11	

Thermal memory 20 minutes before and after tripping

I Instantaneous

Pick-up (A) accuracy ± 15%	$I_i \times$	60 A	1.5	2	3	4	6	8	10	12	15
		100 A	1.5	2	3	4	6	8	10	12	15
		150 A	1.5	2	3	4	6	8	10	12	15
		250 A	1.5	2	3	4	5	6	8	10	12
		400 A	1.5	2	3	4	5	6	8	10	12
		600 A	1.5	2	3	4	5	6	8	10	11
		Non-tripping time Maximum break time		10 ms 50 ms for $I > 1.5 I_i$							

Micrologic 3.2S / 3.3S trip units

L Long-time protection

	I_r		Value depending on sensor rating (I_n) and setting on rotary switch									
	Pick-Up (A) Tripping between 1.05 and 1.20 I_r	$I_n = 60$ A	$I_r =$	15	20	25	30	35	40	45	50	60
$I_n = 100$ A		$I_r =$	35	40	45	50	60	70	80	90	100	
$I_n = 150$ A		$I_r =$	50	60	70	80	90	100	110	125	150	
$I_n = 250$ A		$I_r =$	70	80	100	125	150	175	200	225	250	
$I_n = 400$ A		$I_r =$	125	150	175	200	225	250	300	350	400	
$I_n = 600$ A		$I_r =$	200	225	250	300	350	400	450	500	600	

Time Delay (s) Accuracy 0 to -20%	t_r		non-adjustable										
		$1.5 \times I_r$		400									
		$6 \times I_r$		16									
$7.2 \times I_r$			11										

Thermal memory 20 minutes before and after tripping

S Short-time protection

Pick-up (A) accuracy ± 10%	$I_{sd} - I_r \times \dots$	1.5	2	3	4	5	6	7	8	10	
Time delay (ms)	t_{sd}	non-adjustable									
	Non-tripping time Maximum break time	20 80									

I Instantaneous

Pick-up (A) accuracy ± 15%	$I_i \times I_n$	1.5	2	3	4	6	8	10	12	15	
	Non-tripping time Maximum break time		10 ms 50 ms for $I > 1.5 I_i$								

¹ If the trip units are used in high-temperature environments, the Micrologic trip unit setting must take into account the thermal limitations of the circuit breaker. See the temperature derating information on page 126.

MULTIPLES OF I_n

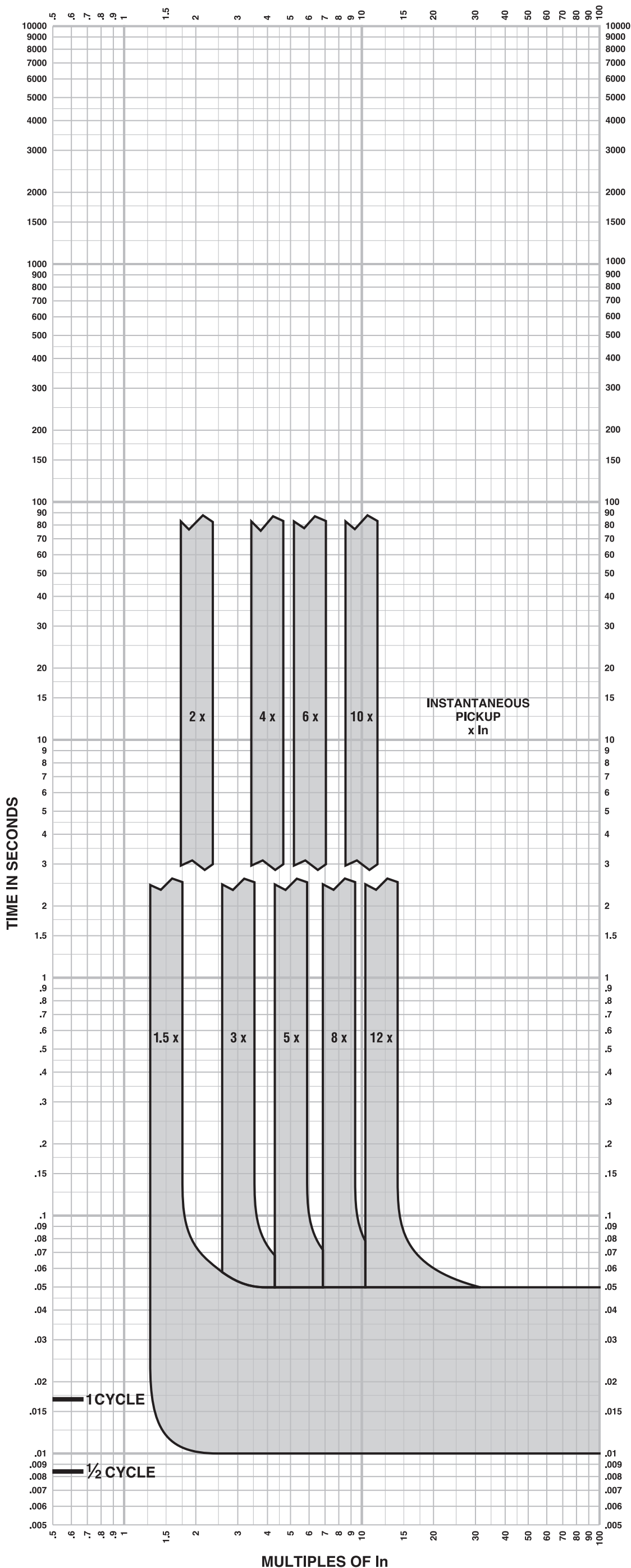

MICROLOGIC™ ELECTRONIC TRIP UNITS
Micrologic™ 3.2/3.2S/5.2A or E/6.2A or E
Instantaneous Trip Curve
250A J-Frame

The time-current curve information is to be used for application and coordination purposes only.

Notes:

1. There is a thermal-imaging effect that can act to shorten the long-time delay. The thermal imaging effect comes into play if a current above the long-time delay pickup value exists for a time and then is cleared by the tripping of a downstream device or the circuit breaker itself. A subsequent overload will cause the circuit breaker to trip in a shorter time than normal. The amount of time delay reduction is inverse to the amount of time that has elapsed since the previous overload. Approximately 20 minutes is required between overloads to completely reset thermal-imaging.
 2. Total clearing times shown include the response times of the trip unit, the circuit breaker opening, and the extinction of the current.
 3. I_n = Maximum dial setting of I_r .
 250A J-Frame: I_n = 250A = Max I_r setting
- Curves apply from -35°C to $+70^{\circ}\text{C}$ (-31°F to $+158^{\circ}\text{F}$) ambient temperature.

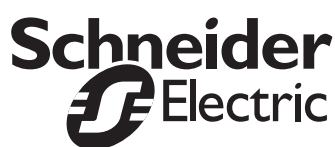

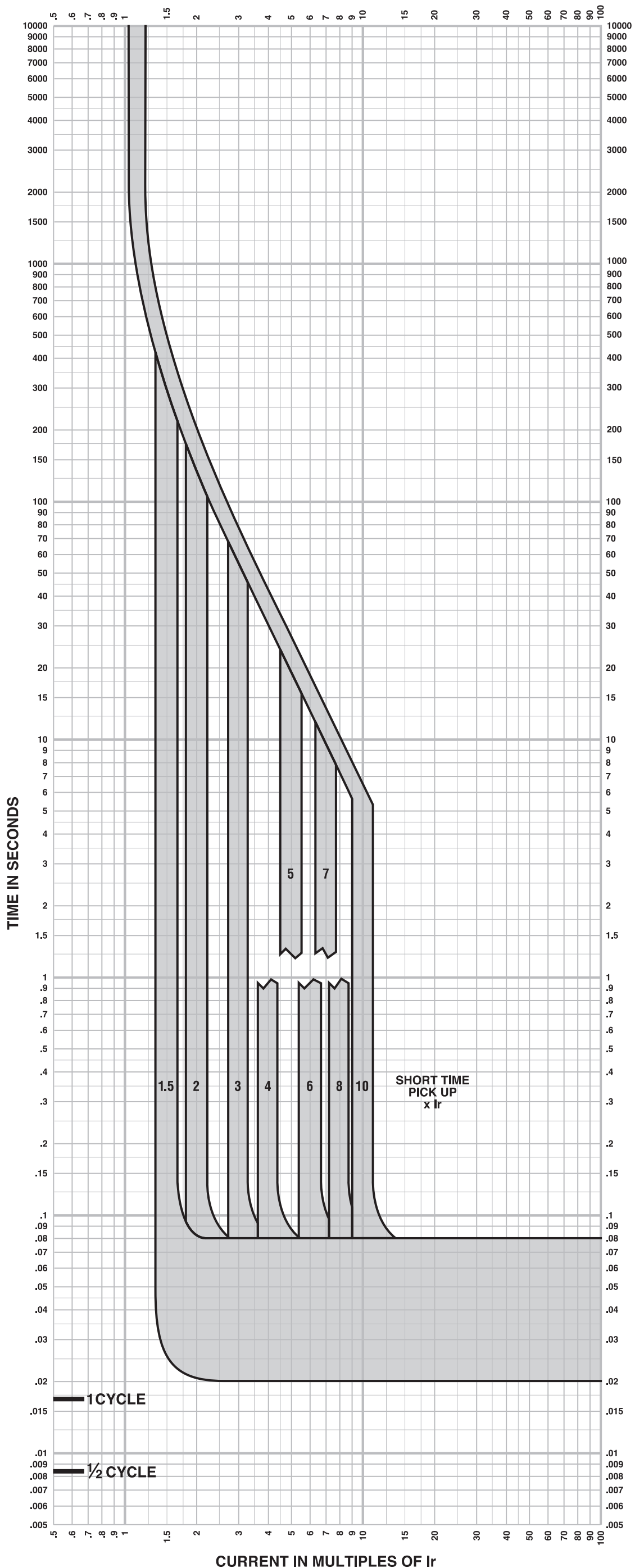

MICROLOGIC™ ELECTRONIC TRIP UNITS
Micrologic™ 3.2S Long Time/
Short Time Trip Curve
250A J-Frame

The time-current curve information is to be used for application and coordination purposes only.

Notes:

1. There is a thermal-imaging effect that can act to shorten the long-time delay. The thermal imaging effect comes into play if a current above the long-time delay pickup value exists for a time and then is cleared by the tripping of a downstream device or the circuit breaker itself. A subsequent overload will cause the circuit breaker to trip in a shorter time than normal. The amount of time delay reduction is inverse to the amount of time that has elapsed since the previous overload. Approximately 20 minutes is required between overloads to completely reset thermal-imaging.
2. Total clearing times shown include the response times of the trip unit, the circuit breaker opening, and the extinction of the current.

Curves apply from -35°C to $+70^{\circ}\text{C}$ (-31°F to $+158^{\circ}\text{F}$) ambient temperature.



Dual wall sub-base diesel fuel tanks - 10-200 kW generator sets



Description

Cummins® offers two series of fuel tanks (basic series and regional series) for the 10~125 kW diesel generator sets. The “basic” series of fuel tanks provide economical solutions for areas with no or minimal local/regional code requirements on diesel fuel tanks. The footprint of “basic” tanks matches the generator set’s footprint. The “regional” series of fuel tanks provide flexible and upgradable solutions for areas with extensive local/regional code requirements on diesel fuel tanks. The footprint of the “regional” series of fuel tanks extends beyond the generator set to allow room for installation of optional features at factory or accessories in the field for meeting local/regional code requirements or customer specification on diesel fuel tanks. All fuel tanks and optional features are compatible with factory installed enclosures.

These tanks are constructed of heavy gauge steel and include an internally reinforced baffle structure for supporting the generator set. The fuel tank design features fewer seams and welds for better corrosion resistance performance.

These tanks are pre-treated with a conversion coating and then finished with a textured powder paint. The paint has superior UV and chemical resistance with best-in-class adhesion, flexibility, and durability to resist chipping and substrate corrosion. Both interior compartments are treated with a rust preventative for extended corrosion protection.

These tanks are UL and ULC Listed as secondary containment generator base tanks. Inner and outer containments are leak checked per UL and ULC testing procedures to ensure their integrity.

These fuel tanks are offered in various sizes to satisfy different fuel capacities requirements.

Compatible generator set model

Engine	D1703M	V2203M	4BT3.3-G5	4BTAA3.3-G7	QSB5-G5	QSB7-G5
Generator set model names	C10D6	C20D6	C25D6	C50D6	C50D6C	C125D6D
	C15D6		C30D6	C60D6	C60D6C	C150D6D
			C35D6		C80D6C	C175D6D
			C40D6		C100D6C	C200D6D
					C125D6C	

Regional fuel tanks

Standard features:

UL 142 and ULC-S601 listed - Minimum 110% secondary IBC 2012 and 2015 certified - All optional features are seismically certified with this range of tanks and generator sets. Requires factory-installed 2 ft vent extensions or higher.

UL 142 & ULC-S601 listed - Minimum 125% secondary containment capacity.

NFPA & IFC - Capable of meeting NFPA 30, NFPA 110, and IFC codes with available factory-installed optional features.

Emergency pressure relief vents - Ensure adequate ventilation of the primary and secondary tank compartments under extreme temperature and emergency conditions.

Normal atmospheric vent - "Mushroom" style vent ensures adequate venting of the primary tank during fill, generator set running, and temperature variations. Raised above fuel fill.

Raised fuel fill - Includes lockable sealed fuel cap.

Lifting eyes - Allow lifting of fuel tank with generator set installed.

Optional features:

Secondary containment basin switch (rupture switch) - Activates a warning in the event of a primary tank leak. Side Mounted.

Low fuel level switch - Activates a warning when 40% of the fuel is left in the tank.

Fuel level gauge - Provides direct reading of fuel level. Top mounted.

Electric fuel level sender with gauge - Allows remote electrical monitoring of fuel tank level. Flying leads for customer connection.

Tank to foundation clearance - 2-inch bolt-thru risers allow visual inspection under tank including rodent barrier.

Spill containment box for fuel fill - 5 gallon capacity with integral drain (to tank). Lockable lid.

Overfill prevention valve - Shuts off fuel flow during filling at approximately 95% full*. Includes fill down tube, as needed, to terminate within 6" of the bottom of the fuel tank. Uses a 2 inch type "F" cam lock adapter for filling.

High fuel switch - Activates at 90% of full fuel level. Flying leads for customer connection.

High fuel alarm panel - Provides audible & visual alarm when fuel level reaches 90% of full fuel level.

Fill drop tube - Terminates fuel fill location within 6" of the bottom of the fuel tank.

Vent extensions - Terminate normal and emergency vents (both primary and secondary) a minimum of 12 ft above the bottom of tank.

Seismic vent extensions - 2 ft normal and emergency (both primary & secondary) extensions to meet IBC/OSHPD seismic requirements.

* The OFPV inherently shuts off fuel at approximately 2" below the top of the fuel tank. Some tanks will shut off below this 95% fill level.

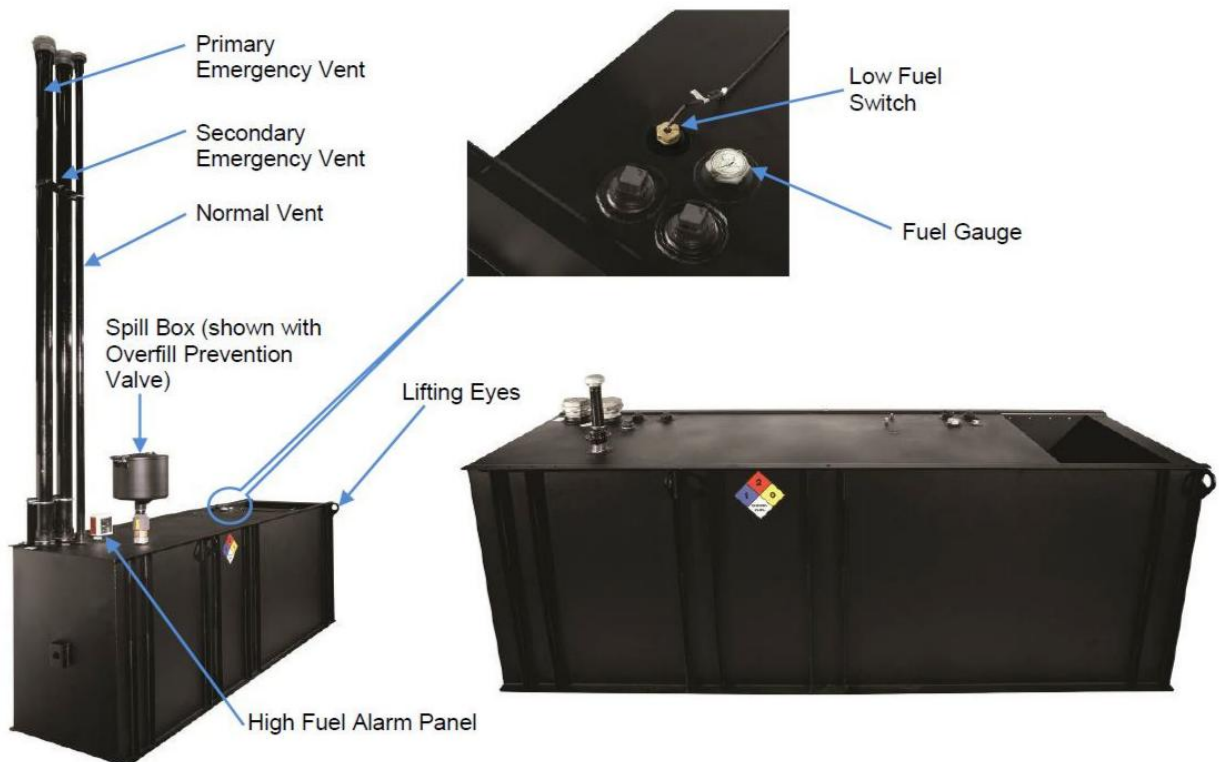

*Picture is for reference only. See outline drawing for tank specific information by model.

Regional tanks

Generator set Standby power output	Generator set model	Engine model	Fuel consumption (100% load, Standby)	Tank feature code	Minimum run time feature	Tank dimensions (L x W x H)	Nominal dry weight*	Tank usable volume	Actual run time w/o OFPV	Actual run time w/OFPV
kW			gal/hr		hr	inch	lbs	gal	hr	hr
10	C10 D6	D1703M	1.12	C301-2	24	87.6 x 34 x 15	510	74	66	56
				C303-2	48	87.6 x 34 x 15	510	74	66	56
				C305-2	72	87.6 x 34 x 23	723	132	118	107
				C307-2	96	87.6 x 34 x 23	723	132	118	107
15	C15 D6	D1703M	1.38	C301-2	24	87.6 x 34 x 15	510	74	53	45
				C303-2	48	87.6 x 34 x 15	510	74	53	45
				C305-2	72	87.6 x 34 x 23	723	132	95	86
				C307-2	96	87.6 x 34 x 32	962	195	141	132
20	C20 D6	V2203M	1.81	C301-2	24	87.6 x 34 x 15	510	74	41	35
				C303-2	48	87.6 x 34 x 23	723	132	73	66
				C305-2	72	87.6 x 34 x 32	962	195	108	101
				C307-2	96	87.6 x 34 x 32	962	195	108	101
25	C25 D6	4BT3.3-G5	2.42	C301-2	24	121 x 34 x 10.5	514	74	31	25
				C303-2	48	121 x 34 x 16.2	686	132	54	47
				C305-2	72	121 x 34 x 22.1	879	195	80	73
				C307-2	96	121 x 34 x 29.5	1120	263	109	101
30	C30 D6	4BT3.3-G5	2.81	C301-2	24	121 x 34 x 10.5	514	74	26	21
				C303-2	48	121 x 34 x 22.1	879	195	69	63
				C305-2	72	121 x 34 x 29.5	1120	263	94	87
				C307-2	96	121 x 34 x 42.0	1461	389	138	132
35	C35 D6	4BT3.3-G5	3.16	C301-2	24	121 x 34 x 16.2	686	132	42	36
				C303-2	48	121 x 34 x 22.1	879	195	62	56
				C305-2	72	121 x 34 x 29.5	1120	263	83	77
				C307-2	96	121 x 34 x 42.0	1461	389	123	117
40	C40 D6	4BT3.3-G5	3.66	C301-2	24	121 x 34 x 16.2	686	132	36	31
				C303-2	48	121 x 34 x 22.1	879	195	53	48
				C305-2	72	121 x 34 x 42.0	1461	389	106	101
				C307-2	96	121 x 34 x 42.0	1461	389	106	101
50	C50 D6	4BTAA3.3-G7	4.25	C301-2	24	121 x 34 x 16.2	686	132	31	27
				C303-2	48	121 x 34 x 29.5	1120	263	62	58
				C305-2	72	121 x 34 x 42.0	1461	389	92	87
60	C60 D6	4BTAA3.3-G7	5.04	C301-2	24	121 x 34 x 16.2	686	132	26	23
				C303-2	48	121 x 34 x 29.5	1120	263	52	49
				C305-2	72	121 x 34 x 42.0	1461	389	77	73
50	C50D6C	QSB5-G5	5.30	C301-2	24	154 x 40 x 22	1388	250	47	45
				C303-2	48	154 x 40 x 32	1657	425	80	76
				C305-2	72	154 x 40 x 32	1657	425	80	76
				C307-2	96	154 x 40 x 46	2096	625	118	112
60	C60D6C	QSB5-G5	6.10	C301-2	24	154 x 40 x 22	1388	250	41	39
				C303-2	48	154 x 40 x 32	1657	425	70	66
				C305-2	72	154 x 40 x 46	2096	625	102	97
				C307-2	96	154 x 40 x 46	2096	625	102	97
80	C80D6C	QSB5-G5	7.30	C301-2	24	154 x 40 x 22	1388	250	34	33
				C303-2	48	154 x 40 x 32	1657	425	58	55
				C305-2	72	154 x 40 x 46	2096	625	85	81
100	C100D6C	QSB5-G5	8.90	C301-2	24	154 x 40 x 22	1388	250	28	27
				C303-2	48	154 x 40 x 32	1657	425	48	45
				C305-2	72	154 x 40 x 46	2096	625	70	66
125	C125D6C	QSB5-G6	10.30	C301-2	24	154 x 40 x 22	1388	250	24	23
				C303-2	48	154 x 40 x 46	2096	625	60	58

* All weights are approximate.

Regional tanks

Generator set Standby power output	Generator set model	Engine model	Fuel consumption (100% load, Standby)	Tank feature code	Minimum run time feature	Tank dimensions (L x W x H)	Nominal dry weight*	Tank usable volume	Actual run time w/o OFPV	Actual run time w/OFPV
kW			gal/hr		hr	inch	lbs	gal	hr	hr
125	C125D6D	QSB7-G5	10.1	C301-2	24	180x40x21	1477	351	34	30
				C303-2	48	180x40x42	2302	737	72	69
				C305-2	72	180x40x42	2302	737	72	69
				C307-2	96	180x65.5x35.3	3552	1055	104	98
150	C150D6D		11.7	C301-2	24	180x40x21	1477	351	30	26
				C303-2	48	180x40x42	2302	737	63	59
				C305-2	72	180x65.5x35.3	3552	1055	90	84
175	C175D6D		13.3	C301-2	24	180x40x21	1477	351	26	23
				C303-2	48	180x40x42	2302	737	55	52
				C305-2	72	180x65.5x35.3	3552	1055	79	74
200	C200D6D		14.9	C301-2	24	180x40x21	1477	351	24	21
				C303-2	48	180x40x42	2302	737	49	47
		C305-2		72	180x65.5x35.3	3552	1055	72	66	

Certifications/standards/codes



UL 142 Listed - Cummins dual wall sub-base tanks are UL Listed and constructed in accordance with Underwriters Laboratories Standard UL 142 "steel aboveground tanks for flammable and combustible liquids," as a "secondary containment generator base tank"



NFPA - Cummins tanks are built in accordance with all applicable NFPA codes:

- NFPA 30 - Flammable and Combustible Liquids code
- NFPA 37 - Standard for Installation and use of Stationary Combustible Engine and Gas Turbines
- NFPA 110 - Standard for Emergency and Standby Power Systems



ISO9001 - This product was designed and manufactured in facilities certified to ISO9001.



ULC - Cummins tanks are built in accordance with all applicable ULC codes

For more information contact your local Cummins distributor or visit power.cummins.com

Our energy working for you.™

REL NO	LTR	NO	REVISION	OWN	CAD	APVD	DATE
ECO-156396	C	1	A052K399 WAS A048C269 IN BOM	DKS	MMJM	JAWALE	19OCT15
		2	CHANGED APPLICATION STATUS TO	-	-	-	-
			'ACCESSORY ONLY' FROM 'PRODUCTION ONLY'	-	-	-	-
			IN MATRIX.	DKS	MMJM	JAWALE	19OCT15

NOTES:
1. (NOTE REMOVED)

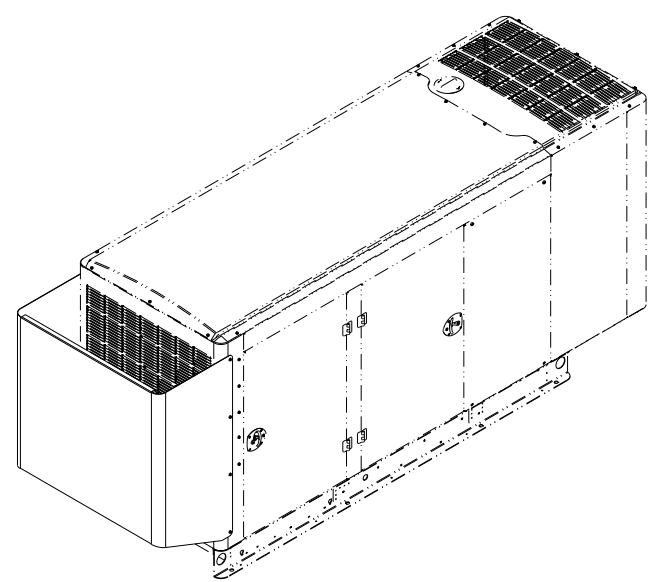
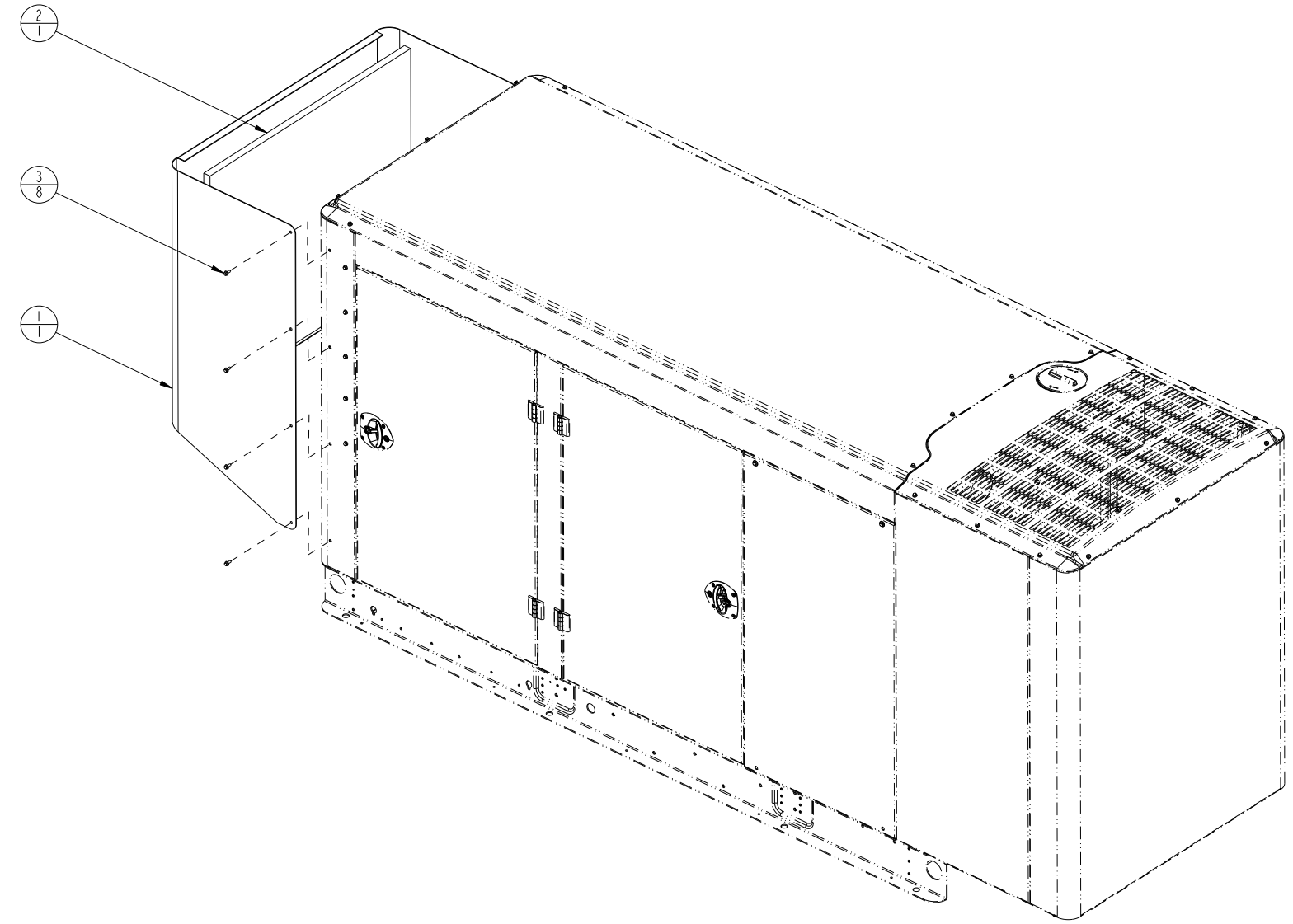

SCALE 1/16
3D VIEW

-THIS IS A CONTROLLED ITEM-
PER POLICY PROCEDURE PPG-1-01-01-116
TO MAINTAIN COMPLIANCE WITH REQUIREMENTS OF THE CODES, STANDARDS, OR AGENCIES LISTED BELOW
 CSA IN CE NVIA ABC
 IRC OTHER

CHANGES, DEVIATIONS, OR SUBSTITUTIONS OF MATERIAL, PROCESS, OR PERFORMANCE CRITERIA MUST BE APPROVED BY THE FOLLOWING CONTROLLED ITEM APPROVER
RESPONSIBLE CIA ROLE: STATIONARY GENSET CIA
RESPONSIBLE CIA ROLE:

UNLESS OTHERWISE SPECIFIED, ALL DIMENSIONS ARE IN MILLIMETERS

CH	UNIT	MIN	MAX	TOL
X	± 1	0.00	4.99	+0.15/-0.08
.X	± 0.8	5.00	9.99	+0.20/-0.10
.XX	± 0.38	10.00	17.49	+0.25/-0.13
.XXX	± 0.38	17.50	24.99	+0.30/-0.13

ANG TOL: ± 1.0° SCALE: 1/8

SIM 10	OWN C. GADE
DO NOT SCALE PRINT	CAD N. KASIBHOTLA
	APVD M. WICKMANN
	DATE 06MAY15
	SITE CODE
- CONFIDENTIAL - PROPERTY OF CUMMINS POWER GENERATION GROUP	FIRST USED ON ARROW
	PGF

CUMMINS POWER GENERATION	
INSTALLATION, ENCLOSURE	
REV D	A052M018
SHEET 1 OF 1	REV C

Instruction Sheet

A052L825 (Issue 2)

8-2015

Installation Instructions for Enclosure Kits A052M016 and A052M018

1 Introduction

The information contained within is based on information available at the time of going to print. In line with Cummins Power Generation policy of continuous development and improvement, information may change at any time without notice. The users should therefore make sure that before commencing any work, they have the latest information available. The latest version of this instruction sheet is available on QuickServe Online (<https://qsol.cummins.com/info/index.html>).

2 Safety Precautions

2.1 General Safety Precautions

WARNING

Hot Pressurized Liquid

Contact with hot liquid can cause severe burns.

Do not open the pressure cap while the engine is running. Let the engine cool down before removing the cap. Turn the cap slowly and do not open it fully until the pressure has been relieved.

WARNING

Moving Parts

Moving parts can cause severe personal injury.

Use extreme caution around moving parts. All guards must be properly fastened to prevent unintended contact.

WARNING

Toxic Hazard

Used engine oils have been identified by some state and federal agencies to cause cancer or reproductive toxicity.

Do not ingest, breathe the fumes, or contact used oil when checking or changing engine oil. Wear protective gloves and face guard.

WARNING

Electrical Generating Equipment

Incorrect operation can cause severe personal injury or death.

Do not operate equipment when fatigued, or after consuming any alcohol or drug.

⚠ WARNING

Toxic Gases

Substances in exhaust gases have been identified by some state and federal agencies to cause cancer or reproductive toxicity.

Do not breathe in or come into contact with exhaust gases.

⚠ WARNING

Combustible Liquid

Ignition of combustible liquids is a fire or explosion hazard which can cause severe burns or death.

Do not store fuel, cleaners, oil, etc., near the generator set.

⚠ WARNING

High Noise Level

Generator sets in operation emit noise, which can cause hearing damage.

Wear appropriate ear protection at all times.

⚠ WARNING

Hot Surfaces

Contact with hot surfaces can cause severe burns.

Wear appropriate PPE when working on hot equipment and avoid physical contact with hot surfaces.

⚠ WARNING

Electrical Generating Equipment

Incorrect operation and maintenance can result in severe personal injury or death

Make sure that only suitably trained and experienced service personnel perform electrical and/or mechanical service.

⚠ WARNING

Toxic Hazard

Ethylene glycol, used as an engine coolant, is toxic to humans and animals.

Wear appropriate PPE. Clean up coolant spills and dispose of used coolant in accordance with local environmental regulations.

⚠ WARNING

Combustible Liquid

Ignition of combustible liquids is a fire or explosion hazard which can cause severe burns or death.

Do not use combustible liquids like ether.

⚠ WARNING

Automated Machinery

Accidental or remote starting of the generator set can cause severe personal injury or death.

Isolate all auxiliary supplies and use an insulated wrench to disconnect the starting battery cables (negative [-] first).

⚠ WARNING

Fire Hazard

Materials drawn into the generator set are a fire hazard. Fire can cause severe burns or death. Keep the generator set and the surrounding area clean and free from obstructions.

⚠ WARNING

Fire Hazard

Materials drawn into the generator set are a fire hazard. Fire can cause severe burns or death. Make sure the generator set is mounted in a manner to prevent combustible materials from accumulating under the unit.

⚠ WARNING

Fire Hazard

Accumulated grease and oil are a fire hazard. Fire can cause severe burns or death. Keep the generator set and the surrounding area clean and free from obstructions. Repair oil leaks promptly.

⚠ WARNING

Fire Hazard

Materials drawn into the generator set are a fire hazard. Fire can cause severe burns or death. Keep the generator set and the surrounding area clean and free from obstructions.

NOTICE

Keep multi-class ABC fire extinguishers handy. Class A fires involve ordinary combustible materials such as wood and cloth. Class B fires involve combustible and flammable liquid fuels and gaseous fuels. Class C fires involve live electrical equipment. (Refer to NFPA No. 10 in applicable region.)

NOTICE

Before performing maintenance and service procedures on enclosed generator sets, make sure the service access doors are secured open.

NOTICE

Stepping on the generator set can cause parts to bend or break, leading to electrical shorts, or to fuel, coolant, or exhaust leaks. Do not step on the generator set when entering or leaving the generator room.

2.2 Generator Set Safety Code

Before operating the generator set, read the manuals and become familiar with them and the equipment. Safe and efficient operation can be achieved only if the equipment is properly operated and maintained. Many accidents are caused by failure to follow fundamental rules and precautions.

⚠ WARNING

Electrical Generating Equipment

Incorrect operation and maintenance can result in severe personal injury or death.

Read and follow all Safety Precautions, Warnings, and Cautions throughout this manual and the documentation supplied with the generator set.

2.3 Electrical Shocks and Arc Flashes Can Cause Severe Personal Injury or Death

⚠ WARNING

Electric Shock Hazard

Voltages and currents present an electrical shock hazard that can cause severe burns or death.

Contact with exposed energized circuits with potentials of 50 Volts AC or 75 Volts DC or higher can cause electrical shock and electrical arc flash. Refer to standard NFPA 70E or equivalent safety standards in corresponding regions for details of the dangers involved and for the safety requirements.

Guidelines to follow when working on de-energized electrical systems:

- Use proper PPE. Do not wear jewelry and make sure that any conductive items are removed from pockets as these items can fall into equipment and the resulting short circuit can cause shock or burning. Refer to standard NFPA 70E for PPE standards.
- De-energize and lockout/tagout electrical systems prior to working on them. Lockout/Tagout is intended to prevent injury due to unexpected start-up of equipment or the release of stored energy.
- De-energize and lockout/tagout all circuits and devices before removing any protective shields or making any measurements on electrical equipment.
- Follow all applicable regional electrical and safety codes.

In summary:

- Do not tamper with or bypass interlocks unless you are authorized to do so.
- Understand and assess the risks - use proper PPE.
- Make sure that an accompanying person who can undertake a rescue is nearby.

3 Instruction

3.1 Installation of Enclosure Kits A052M016 and A052M018

This instruction sheet describes the installation of enclosure kits A052M016 and A052M018.

Read these installation instructions completely and become familiar with safety warnings, cautions and installation procedure before starting.

1. Wipe surfaces where insulation will be attached with a rag and water to remove physical debris. Let dry.
2. Remove the release liner from the insulation pieces and apply the insulation in the location shown in the figure below. Be sure to press down firmly on all areas of insulation to engage the pressure-sensitive adhesive.

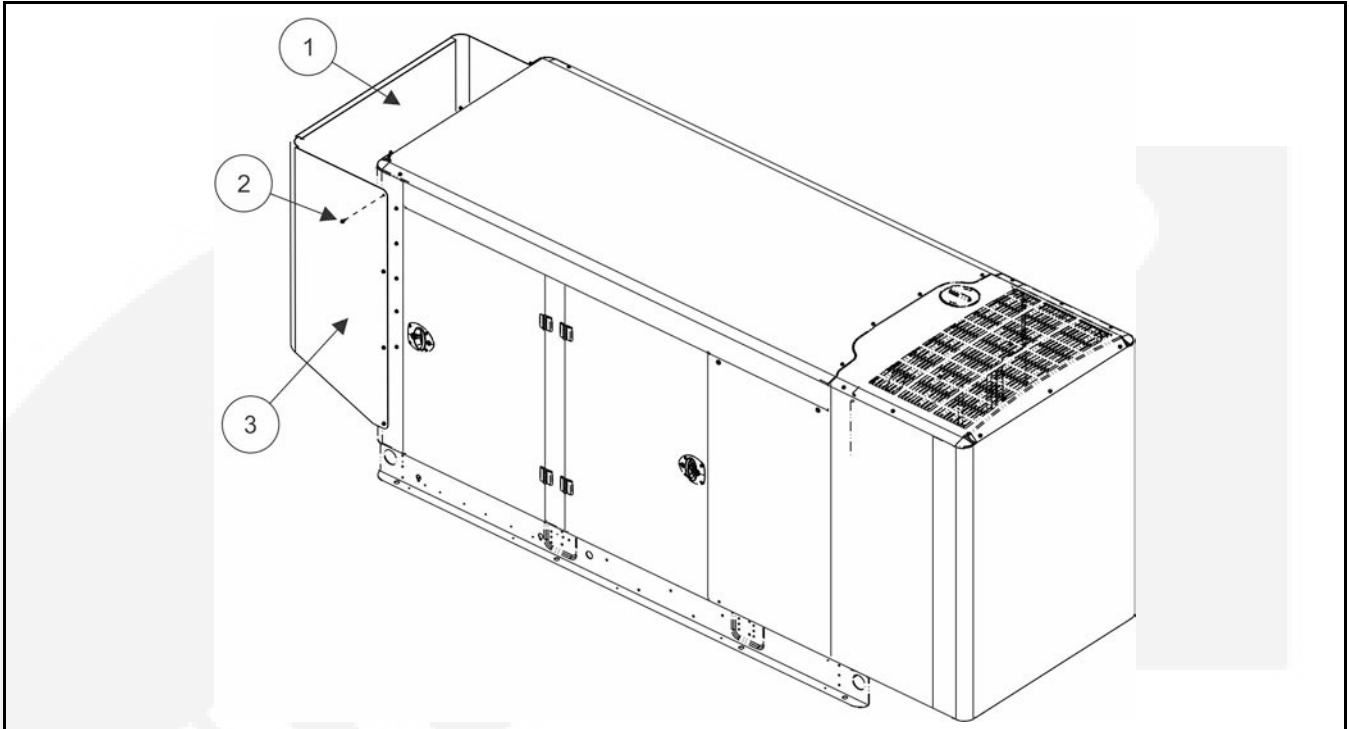

No.	Description	No.	Description
1	Panel Insulation	3	Inlet Duct
2	Hex Flange Head Screw		

FIGURE 1. ENCLOSURE KIT ATTACHED TO GENERATOR SET

3. Make sure there is no debris in the mounting holes.
4. Make sure the sloped end of the inlet duct is on the bottom, as shown in the figure above.
5. Bolt the inlet duct to the enclosed generator set.
6. Tighten the bolts. Torque to 4.4 - 5.9 ft-lb (6 - 8 Nm).





Battery Charger-6 Amp

A045D925 60Hz/50Hz



Description

Cummins® fully automatic battery chargers are designed to both recharge your batteries, and extend your battery's life in applications where it is stored for long periods of time. This charger can handle poor power quality, exposure to extreme weather and rough handling.

To maximize battery life, a 3-stage charging cycle is implemented. The three charging stages are bulk stage, absorption stage and maintenance stage. During the bulk stage, the charger uses its full amp output to do the heaviest charging, quickly bringing your battery to about 75% of capacity. In the absorption stage, the current slows, adjusting for maximum charging efficiency while it gently tops off the battery to about 98% of capacity.

During the maintenance stage, a lower, closely-regulated, constant voltage is applied to maintain full charge and prevent discharge.

Unlike some "trickle chargers," the float charger won't apply more current than necessary to maintain full charge. Batteries can be connected indefinitely, without harm; in fact, the float charge extends battery life.

Features

Protection – Surge protected to IEEE and EN standards. All models include single pole cartridge type fuses mounted on the printed circuit board to protect against input or output overcurrent.

Lightweight and Silent – Lighter than transformer types, completely silent but still provides full output when overloaded outlets drop AC voltage below the normal 115V.

Monitoring – Status LED indicators are provided to show the condition or charging status of the battery. When the red LED is on, it indicates that the battery is discharged and is recharging at the 'BULK' rate. When both the red and green LEDs are on, the battery is charging at the 'midrange' rate. When the green LED is on, the battery is 90% charged and ready for use.

Construction – Made using epoxy-potted cases making it the ultimate in durability, completely waterproof and able to withstand numerous caustic chemicals and gases, as well as being shockproof.

Fault Indication – The charger senses and indicates the following fault conditions: Defective or damaged cells, under-voltage at the battery, battery drawing more current than charger can replace, loss of power or extremely low AC voltage at the charger, other battery fault conditions and charger failure.

Compatibility – Works with Sealed Lead Acid (SLA), Absorbed Glass Mat (AGM) and Gel type batteries.

Low Electromagnetic and Radio

Frequency Interference – This product meets FCC class B for conducted and radiated emissions.

Listed – This product is UL listed according to the UL 1236 Standard.

Warranty – This product has a two year warranty

Specifications

Performance and Physical Characteristics

Output:	Nominal voltage	12 VDC
	Float voltage – 12 V batteries	13.0-13.6 VDC at 0-2 amps
	Maximum output current	6 A @ 12 VDC nom
Input:	Voltage AC	115, 208, 240 ±10%, 90-135
	Frequency	60 Hz ±5%
Battery:	Maximum battery size	150 Amp Hours
	Maximum recharge time	20 hours
Approximate net weight		4 lbs. (1.81 Kg)
Approximate dimensions: height x width x depth-in(mm)		2.25 x 6.4 x 3.5 (57 x 162 x 89)
Ambient temperature operation: At full rated output		-40°F to 122 °F (-40 °C to 50 °C)



Warning: Back feed to a utility system can cause electrocution and/or property damage. Do not connect generator sets to any building electrical system except through an approved device or after building main switch is open.

Warning: For professional use only. Must be installed by a qualified service technician. Improper installation presents hazards of electrical shock and improper operation, resulting in severe personal injury and/or property damage.

For more information contact your local Cummins distributor
or visit power.cummins.com

Our energy working for you.™



SECTION 4

Generator Drawings



REL NO	LTR	NO	REVISION	OWN	CAD	APVD	DATE
ECO-152551	A	1	PRODUCTION_RELEASE	CG	NK	M.WICKMANN	14MAY15

NOTES:

1. DIM [] IN INCHES
2. WHEN THE HOUSING INSTALLED ON AN OPEN GENERATOR SET, THE TOTAL WEIGHT WILL INCREASE BY 131.5 KG (290 LBS). THIS INCLUDES THE MUFFLER.
3. THE CENTER OF GRAVITY (CG) OF THE GENERATOR SET WHEN EQUIPPED WITH THIS HOUSING SHIFTS APPROXIMATELY 65mm (2.55 inch) TOWARDS THE AIR DISCHARGE END OF THE HOUSING AND 42MM (1.66 INCH) HIGHER FROM THE GROUND, COMPARED TO THE EQUIVALENT NON-HOUSED PRODUCT WITH THE F179 SKID. SEE HOUSING READY SKID BASE OUTLINE DRAWING FOR CG LOCATION OF NON HOUSED PRODUCT.

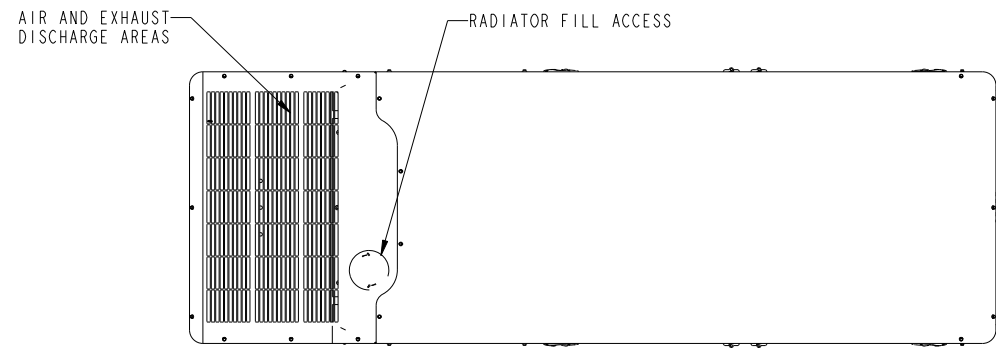
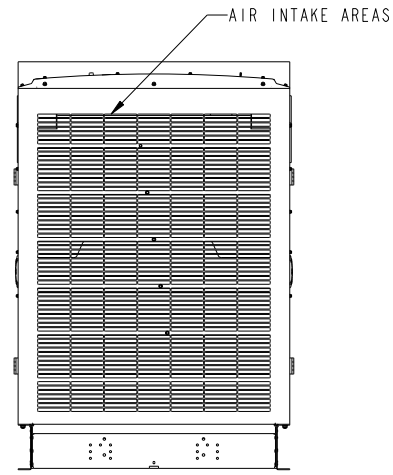

TOP VIEW

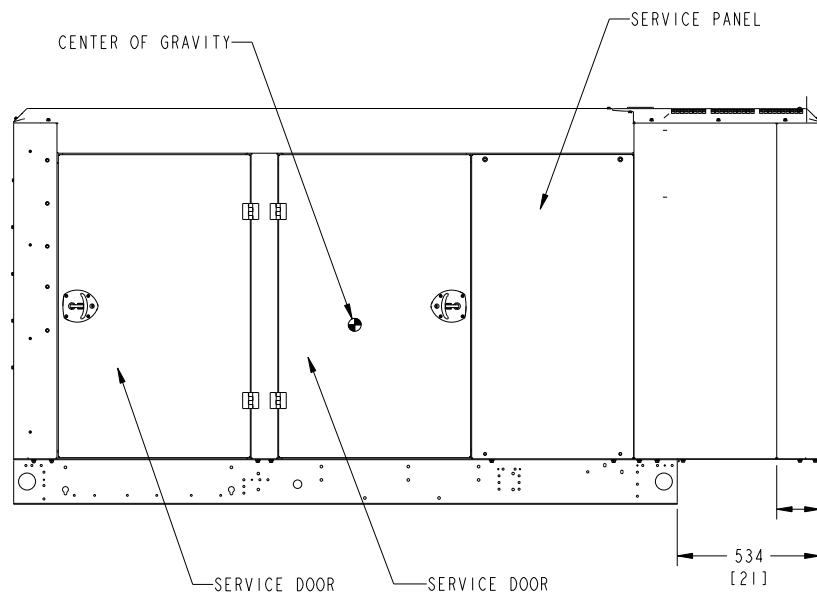

RIGHT SIDE VIEW

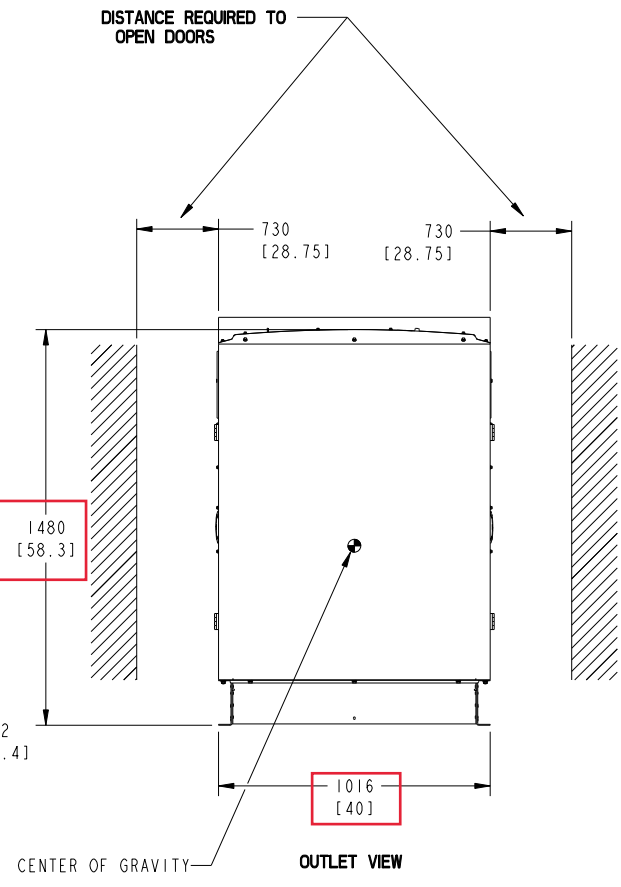

OUTLET VIEW

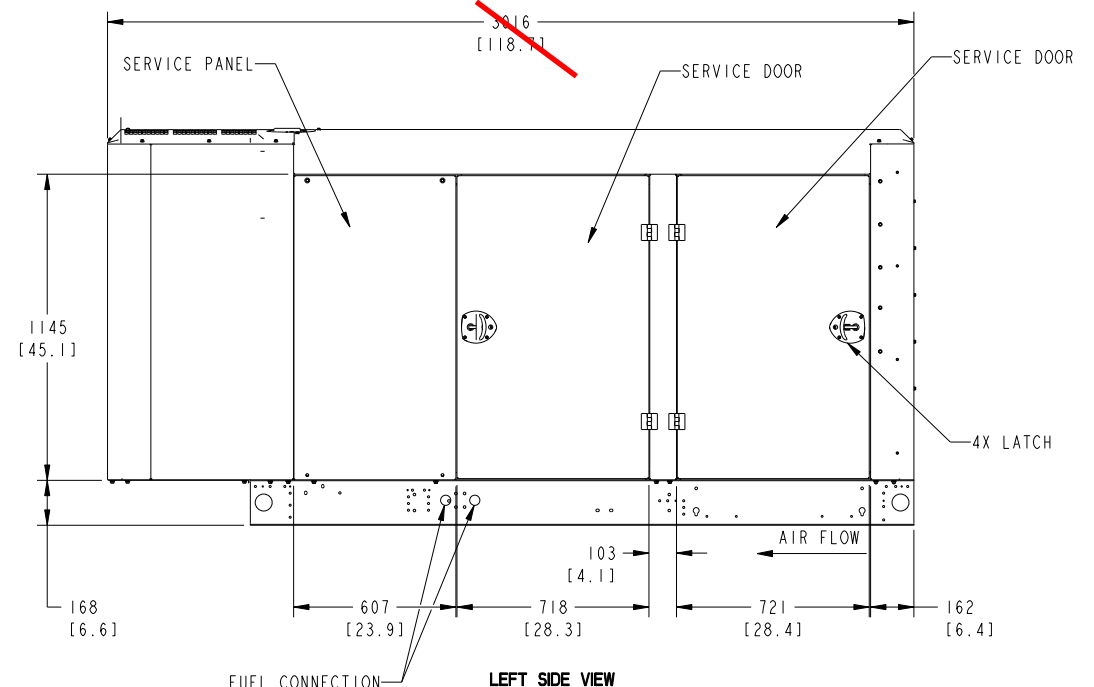

LEFT SIDE VIEW

~~F231-2 ENCLOSURE CONFIGURATION~~

UNLESS OTHERWISE SPECIFIED, ALL DIMENSIONS ARE IN MILLIMETERS		SIM 10 NONE	OWN C. GADE		CUMMINS POWER GENERATION	
DO NOT SCALE PRINT		DO NOT SCALE PRINT	CAD N. KASIBHOTLA		OUTLINE, ENCLOSURE	
CH	XX ± 0.38	0.00- 4.99 +0.15/-0.08 5.00- 9.99 +0.20/-0.10 10.00-17.49 +0.25/-0.13 17.50-24.99 +0.30/-0.13	APVD M. WICKMANN	SITE CODE	A051P365	
ANG TOL: ±	1.0°	SCALE: ~3/32	DATE 14MAY15	PGF	SHEET 1 OF 2	REV A

REL NO	LTR	NO	REVISION	DWN	CAD	APVD	DATE
ECO-152551	A	1	PRODUCTION RELEASE	CG	NK	M. WICKMANN	14MAY15

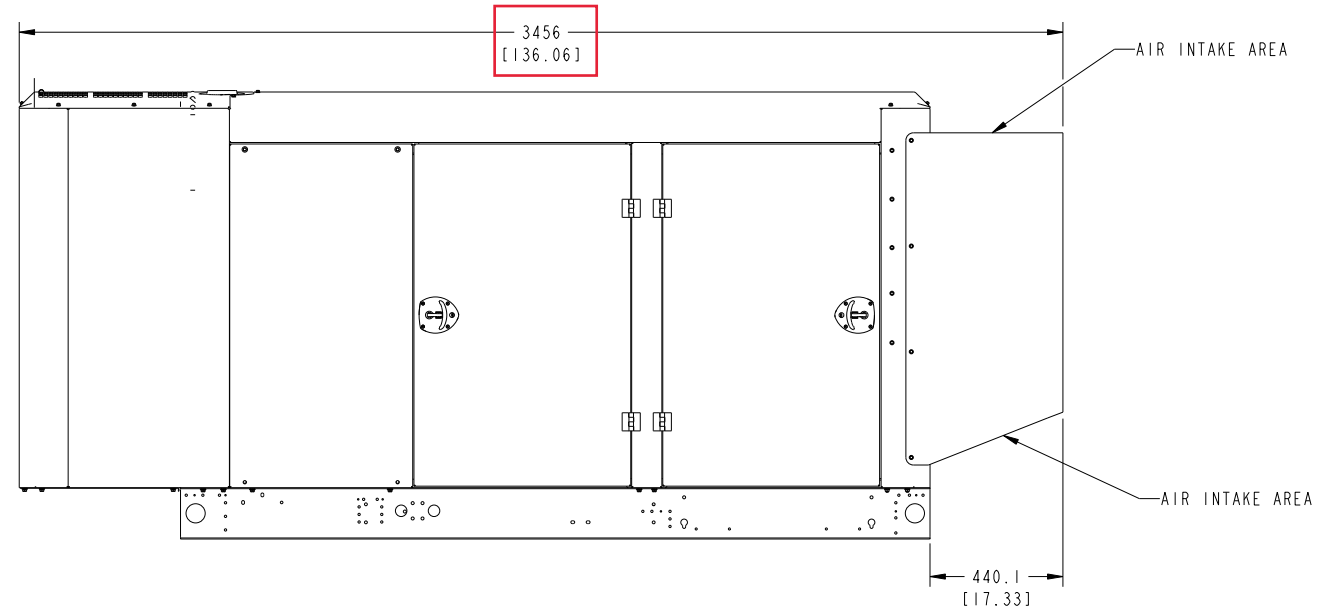
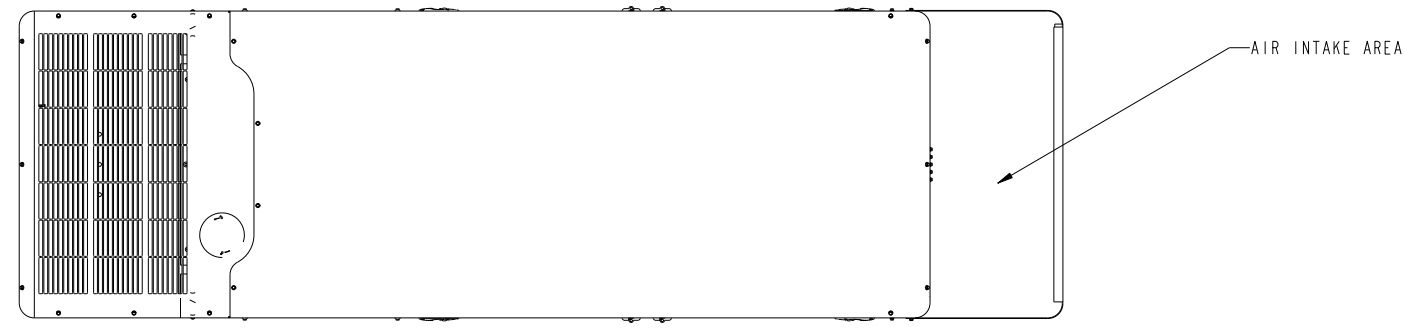

F217-2 ENCLOSURE CONFIGURATION
REFER TO PAGE 1 (F231-2 ENCLOSURE FOR
OTHER F217-2 ENCLOSURE DIMENSIONS.

UNLESS OTHERWISE SPECIFIED, ALL DIMENSIONS ARE IN MILLIMETERS		SIM 10 NONE	DWN C. GADE	CUMMINS POWER GENERATION																						
DO NOT SCALE PRINT			CAD N. KASIBHOTLA		OUTLINE, ENCLOSURE																					
<table border="1"> <tr> <th>DIM</th> <th>TOL</th> <th>SCALE</th> </tr> <tr> <td>X ± 1</td> <td>0.00- 4.99 +0.15/-0.08</td> <td rowspan="3">~3/32</td> </tr> <tr> <td>.X ± 0.8</td> <td>5.00- 9.99 +0.20/-0.10</td> </tr> <tr> <td>.XX ± 0.38</td> <td>10.00-17.49 +0.25/-0.13</td> </tr> <tr> <td></td> <td>17.50-24.99 +0.30/-0.13</td> <td></td> </tr> </table>	DIM	TOL	SCALE	X ± 1		0.00- 4.99 +0.15/-0.08	~3/32	.X ± 0.8	5.00- 9.99 +0.20/-0.10	.XX ± 0.38	10.00-17.49 +0.25/-0.13		17.50-24.99 +0.30/-0.13		ANG TOL: ± 1.0°	<table border="1"> <tr> <td>APVD M. WICKMANN</td> <td>DATE 14MAY15</td> </tr> </table>	APVD M. WICKMANN	DATE 14MAY15	SITE CODE	<table border="1"> <tr> <td>PGF</td> <td>REV A</td> </tr> </table>	PGF	REV A				
DIM	TOL	SCALE																								
X ± 1	0.00- 4.99 +0.15/-0.08	~3/32																								
.X ± 0.8	5.00- 9.99 +0.20/-0.10																									
.XX ± 0.38	10.00-17.49 +0.25/-0.13																									
	17.50-24.99 +0.30/-0.13																									
APVD M. WICKMANN	DATE 14MAY15																									
PGF	REV A																									
<table border="1"> <tr> <td>SCALE: ~3/32</td> <td>PROPERTY OF CUMMINS POWER GENERATION GROUP</td> <td>FOR INTERPRETATION OF DIMENSIONS AND TOLERANCING, SEE ASME Y14.5M-1994</td> </tr> </table>			SCALE: ~3/32	PROPERTY OF CUMMINS POWER GENERATION GROUP	FOR INTERPRETATION OF DIMENSIONS AND TOLERANCING, SEE ASME Y14.5M-1994	<table border="1"> <tr> <td>ARROW</td> <td>PGF</td> </tr> </table>	ARROW	PGF	<table border="1"> <tr> <td>DATE 14MAY15</td> <td>SITE CODE</td> </tr> </table>	DATE 14MAY15	SITE CODE	<table border="1"> <tr> <td>DATE 14MAY15</td> <td>SITE CODE</td> </tr> </table>	DATE 14MAY15	SITE CODE	<table border="1"> <tr> <td>DATE 14MAY15</td> <td>SITE CODE</td> </tr> </table>	DATE 14MAY15	SITE CODE	<table border="1"> <tr> <td>DATE 14MAY15</td> <td>SITE CODE</td> </tr> </table>	DATE 14MAY15	SITE CODE	<table border="1"> <tr> <td>DATE 14MAY15</td> <td>SITE CODE</td> </tr> </table>	DATE 14MAY15	SITE CODE	<table border="1"> <tr> <td>DATE 14MAY15</td> <td>SITE CODE</td> </tr> </table>	DATE 14MAY15	SITE CODE
SCALE: ~3/32	PROPERTY OF CUMMINS POWER GENERATION GROUP	FOR INTERPRETATION OF DIMENSIONS AND TOLERANCING, SEE ASME Y14.5M-1994																								
ARROW	PGF																									
DATE 14MAY15	SITE CODE																									
DATE 14MAY15	SITE CODE																									
DATE 14MAY15	SITE CODE																									
DATE 14MAY15	SITE CODE																									
DATE 14MAY15	SITE CODE																									
DATE 14MAY15	SITE CODE																									
<table border="1"> <tr> <td>SCALE: ~3/32</td> <td>PROPERTY OF CUMMINS POWER GENERATION GROUP</td> <td>FOR INTERPRETATION OF DIMENSIONS AND TOLERANCING, SEE ASME Y14.5M-1994</td> </tr> </table>			SCALE: ~3/32	PROPERTY OF CUMMINS POWER GENERATION GROUP	FOR INTERPRETATION OF DIMENSIONS AND TOLERANCING, SEE ASME Y14.5M-1994	<table border="1"> <tr> <td>ARROW</td> <td>PGF</td> </tr> </table>	ARROW	PGF	<table border="1"> <tr> <td>DATE 14MAY15</td> <td>SITE CODE</td> </tr> </table>	DATE 14MAY15	SITE CODE	<table border="1"> <tr> <td>DATE 14MAY15</td> <td>SITE CODE</td> </tr> </table>	DATE 14MAY15	SITE CODE	<table border="1"> <tr> <td>DATE 14MAY15</td> <td>SITE CODE</td> </tr> </table>	DATE 14MAY15	SITE CODE	<table border="1"> <tr> <td>DATE 14MAY15</td> <td>SITE CODE</td> </tr> </table>	DATE 14MAY15	SITE CODE	<table border="1"> <tr> <td>DATE 14MAY15</td> <td>SITE CODE</td> </tr> </table>	DATE 14MAY15	SITE CODE	<table border="1"> <tr> <td>DATE 14MAY15</td> <td>SITE CODE</td> </tr> </table>	DATE 14MAY15	SITE CODE
SCALE: ~3/32	PROPERTY OF CUMMINS POWER GENERATION GROUP	FOR INTERPRETATION OF DIMENSIONS AND TOLERANCING, SEE ASME Y14.5M-1994																								
ARROW	PGF																									
DATE 14MAY15	SITE CODE																									
DATE 14MAY15	SITE CODE																									
DATE 14MAY15	SITE CODE																									
DATE 14MAY15	SITE CODE																									
DATE 14MAY15	SITE CODE																									
DATE 14MAY15	SITE CODE																									
<table border="1"> <tr> <td>SCALE: ~3/32</td> <td>PROPERTY OF CUMMINS POWER GENERATION GROUP</td> <td>FOR INTERPRETATION OF DIMENSIONS AND TOLERANCING, SEE ASME Y14.5M-1994</td> </tr> </table>			SCALE: ~3/32	PROPERTY OF CUMMINS POWER GENERATION GROUP	FOR INTERPRETATION OF DIMENSIONS AND TOLERANCING, SEE ASME Y14.5M-1994	<table border="1"> <tr> <td>ARROW</td> <td>PGF</td> </tr> </table>	ARROW	PGF	<table border="1"> <tr> <td>DATE 14MAY15</td> <td>SITE CODE</td> </tr> </table>	DATE 14MAY15	SITE CODE	<table border="1"> <tr> <td>DATE 14MAY15</td> <td>SITE CODE</td> </tr> </table>	DATE 14MAY15	SITE CODE	<table border="1"> <tr> <td>DATE 14MAY15</td> <td>SITE CODE</td> </tr> </table>	DATE 14MAY15	SITE CODE	<table border="1"> <tr> <td>DATE 14MAY15</td> <td>SITE CODE</td> </tr> </table>	DATE 14MAY15	SITE CODE	<table border="1"> <tr> <td>DATE 14MAY15</td> <td>SITE CODE</td> </tr> </table>	DATE 14MAY15	SITE CODE	<table border="1"> <tr> <td>DATE 14MAY15</td> <td>SITE CODE</td> </tr> </table>	DATE 14MAY15	SITE CODE
SCALE: ~3/32	PROPERTY OF CUMMINS POWER GENERATION GROUP	FOR INTERPRETATION OF DIMENSIONS AND TOLERANCING, SEE ASME Y14.5M-1994																								
ARROW	PGF																									
DATE 14MAY15	SITE CODE																									
DATE 14MAY15	SITE CODE																									
DATE 14MAY15	SITE CODE																									
DATE 14MAY15	SITE CODE																									
DATE 14MAY15	SITE CODE																									
DATE 14MAY15	SITE CODE																									
<table border="1"> <tr> <td>SCALE: ~3/32</td> <td>PROPERTY OF CUMMINS POWER GENERATION GROUP</td> <td>FOR INTERPRETATION OF DIMENSIONS AND TOLERANCING, SEE ASME Y14.5M-1994</td> </tr> </table>			SCALE: ~3/32	PROPERTY OF CUMMINS POWER GENERATION GROUP	FOR INTERPRETATION OF DIMENSIONS AND TOLERANCING, SEE ASME Y14.5M-1994	<table border="1"> <tr> <td>ARROW</td> <td>PGF</td> </tr> </table>	ARROW	PGF	<table border="1"> <tr> <td>DATE 14MAY15</td> <td>SITE CODE</td> </tr> </table>	DATE 14MAY15	SITE CODE	<table border="1"> <tr> <td>DATE 14MAY15</td> <td>SITE CODE</td> </tr> </table>	DATE 14MAY15	SITE CODE	<table border="1"> <tr> <td>DATE 14MAY15</td> <td>SITE CODE</td> </tr> </table>	DATE 14MAY15	SITE CODE	<table border="1"> <tr> <td>DATE 14MAY15</td> <td>SITE CODE</td> </tr> </table>	DATE 14MAY15	SITE CODE	<table border="1"> <tr> <td>DATE 14MAY15</td> <td>SITE CODE</td> </tr> </table>	DATE 14MAY15	SITE CODE	<table border="1"> <tr> <td>DATE 14MAY15</td> <td>SITE CODE</td> </tr> </table>	DATE 14MAY15	SITE CODE
SCALE: ~3/32	PROPERTY OF CUMMINS POWER GENERATION GROUP	FOR INTERPRETATION OF DIMENSIONS AND TOLERANCING, SEE ASME Y14.5M-1994																								
ARROW	PGF																									
DATE 14MAY15	SITE CODE																									
DATE 14MAY15	SITE CODE																									
DATE 14MAY15	SITE CODE																									
DATE 14MAY15	SITE CODE																									
DATE 14MAY15	SITE CODE																									
DATE 14MAY15	SITE CODE																									

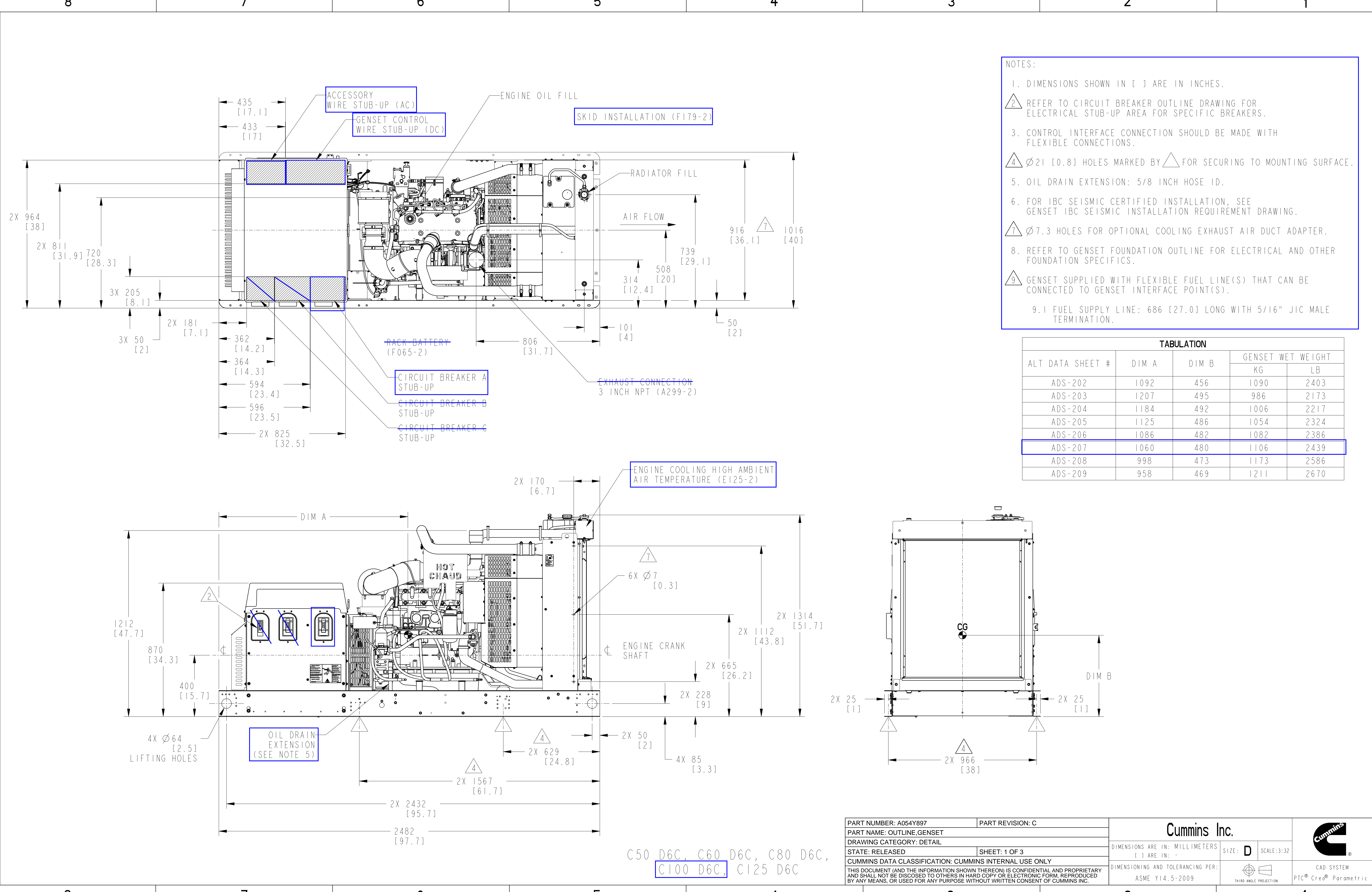

- NOTES:
- DIMENSIONS SHOWN IN [] ARE IN INCHES.
 - REFER TO CIRCUIT BREAKER OUTLINE DRAWING FOR ELECTRICAL STUB-UP AREA FOR SPECIFIC BREAKERS.
 - CONTROL INTERFACE CONNECTION SHOULD BE MADE WITH FLEXIBLE CONNECTIONS.
 - Ø21 [0.8] HOLES MARKED BY \triangle FOR SECURING TO MOUNTING SURFACE.
 - OIL DRAIN EXTENSION: 5/8 INCH HOSE ID.
 - FOR IBC SEISMIC CERTIFIED INSTALLATION, SEE GENSET IBC SEISMIC INSTALLATION REQUIREMENT DRAWING.
 - Ø7.3 HOLES FOR OPTIONAL COOLING EXHAUST AIR DUCT ADAPTER.
 - REFER TO GENSET FOUNDATION OUTLINE FOR ELECTRICAL AND OTHER FOUNDATION SPECIFICS.
 - GENSET SUPPLIED WITH FLEXIBLE FUEL LINE(S) THAT CAN BE CONNECTED TO GENSET INTERFACE POINT(S).
 - FUEL SUPPLY LINE: 686 [27.0] LONG WITH 5/16" JIC MALE TERMINATION.

TABULATION

ALT DATA SHEET #	DIM A	DIM B	GENSET WET WEIGHT	
			KG	LB
ADS-202	1092	456	1090	2403
ADS-203	1207	495	986	2173
ADS-204	1184	492	1006	2217
ADS-205	1125	486	1054	2324
ADS-206	1086	482	1082	2386
ADS-207	1060	480	1106	2439
ADS-208	998	473	1173	2586
ADS-209	958	469	1211	2670

PART NUMBER: A054Y897 PART REVISION: C

PART NAME: OUTLINE, GENSET

DRAWING CATEGORY: DETAIL

STATE: RELEASED SHEET: 1 OF 3

CUMMINS DATA CLASSIFICATION: CUMMINS INTERNAL USE ONLY

THIS DOCUMENT (AND THE INFORMATION SHOWN THEREON) IS CONFIDENTIAL AND PROPRIETARY AND SHALL NOT BE DISCLOSED TO OTHERS IN HARD COPY OR ELECTRONIC FORM, REPRODUCED BY ANY MEANS, OR USED FOR ANY PURPOSE WITHOUT WRITTEN CONSENT OF CUMMINS INC.

Cummins Inc.

DIMENSIONS ARE IN: MILLIMETERS [] ARE IN: - SIZE: D SCALE: 3:32

DIMENSIONING AND TOLERANCING PER: ASME Y14.5-2009

CAD SYSTEM: PTC® Creo® Parametric

C50 D6C, C60 D6C, C80 D6C, C100 D6C, C125 D6C

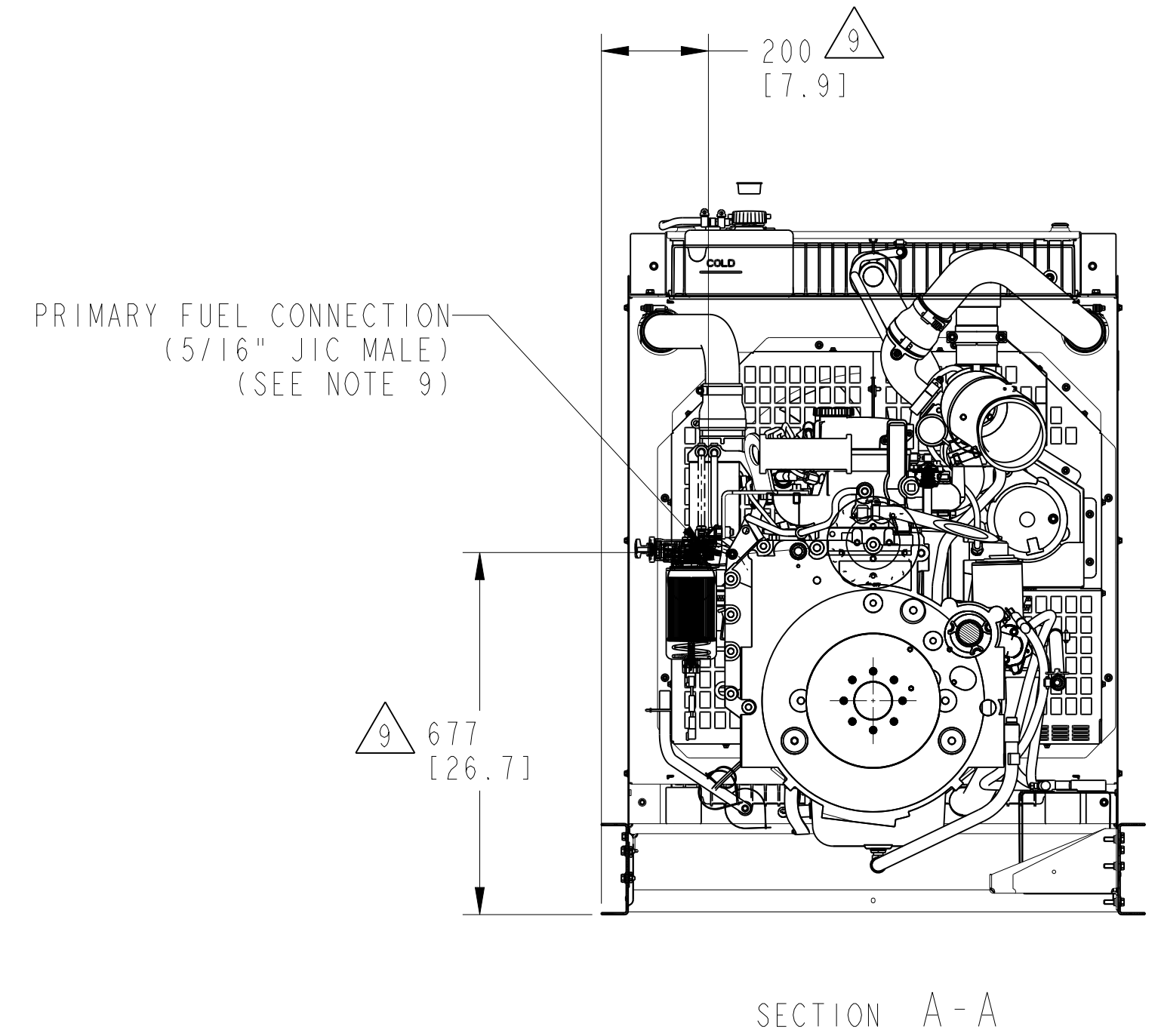
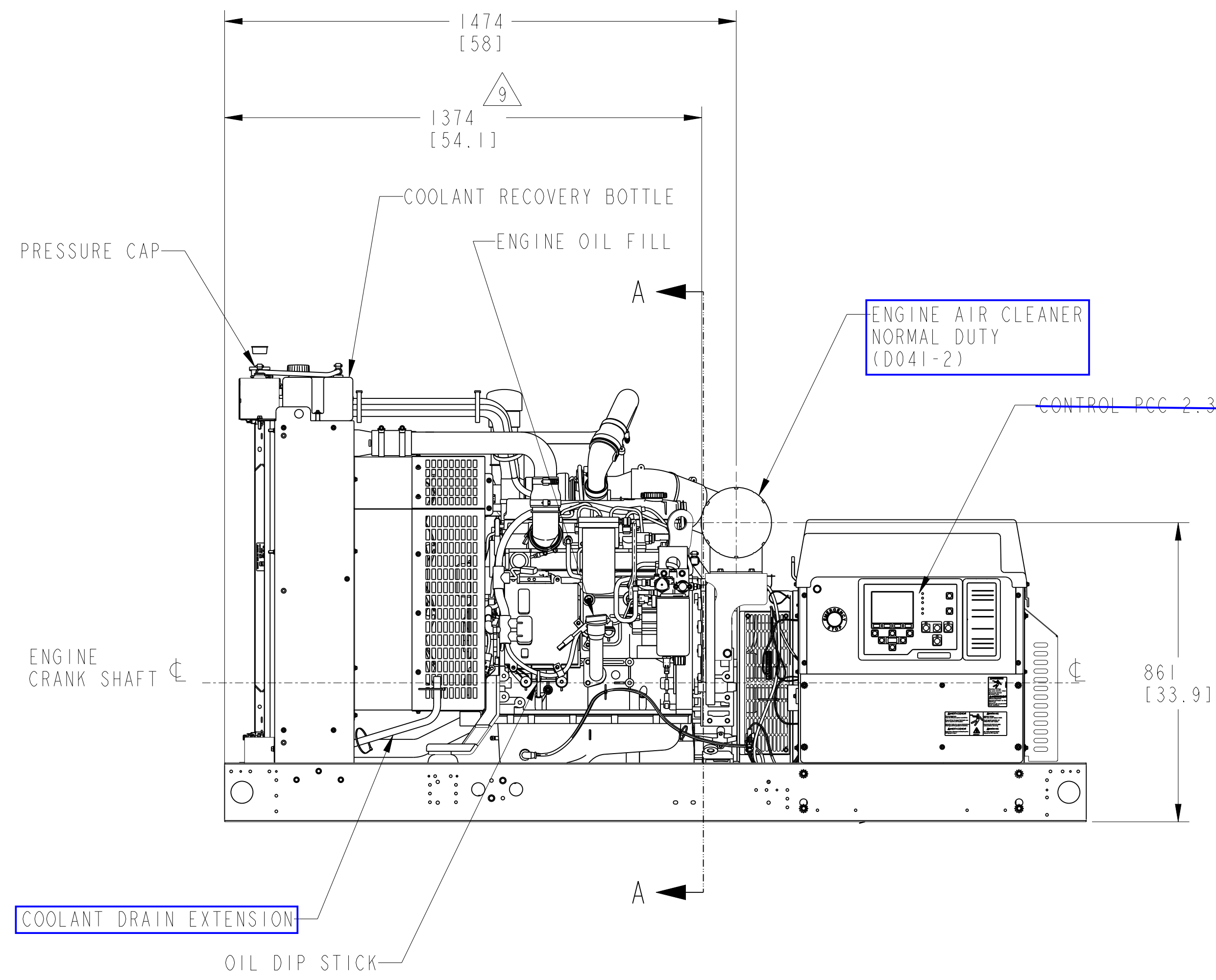

C50 D6C, C60 D6C, C80 D6C,
C100 D6C, C125 D6C

PART NUMBER: A054Y897		PART REVISION: C		Cummins Inc.		
DRAWING CATEGORY: DETAIL						
STATE: RELEASED		SHEET: 2 OF 3		DIMENSIONS ARE IN: MILLIMETERS	SIZE: D	SCALE: 3:32
CUMMINS DATA CLASSIFICATION: CUMMINS INTERNAL USE ONLY				DIMENSIONING AND TOLERANCING PER:		THIRD ANGLE PROJECTION
THIS DOCUMENT (AND THE INFORMATION SHOWN THEREON) IS CONFIDENTIAL AND PROPRIETARY AND SHALL NOT BE DISCLOSED TO OTHERS IN HARD COPY OR ELECTRONIC FORM. REPRODUCED BY ANY MEANS, OR USED FOR ANY PURPOSE WITHOUT WRITTEN CONSENT OF CUMMINS INC.				ASME Y14.5-2009		

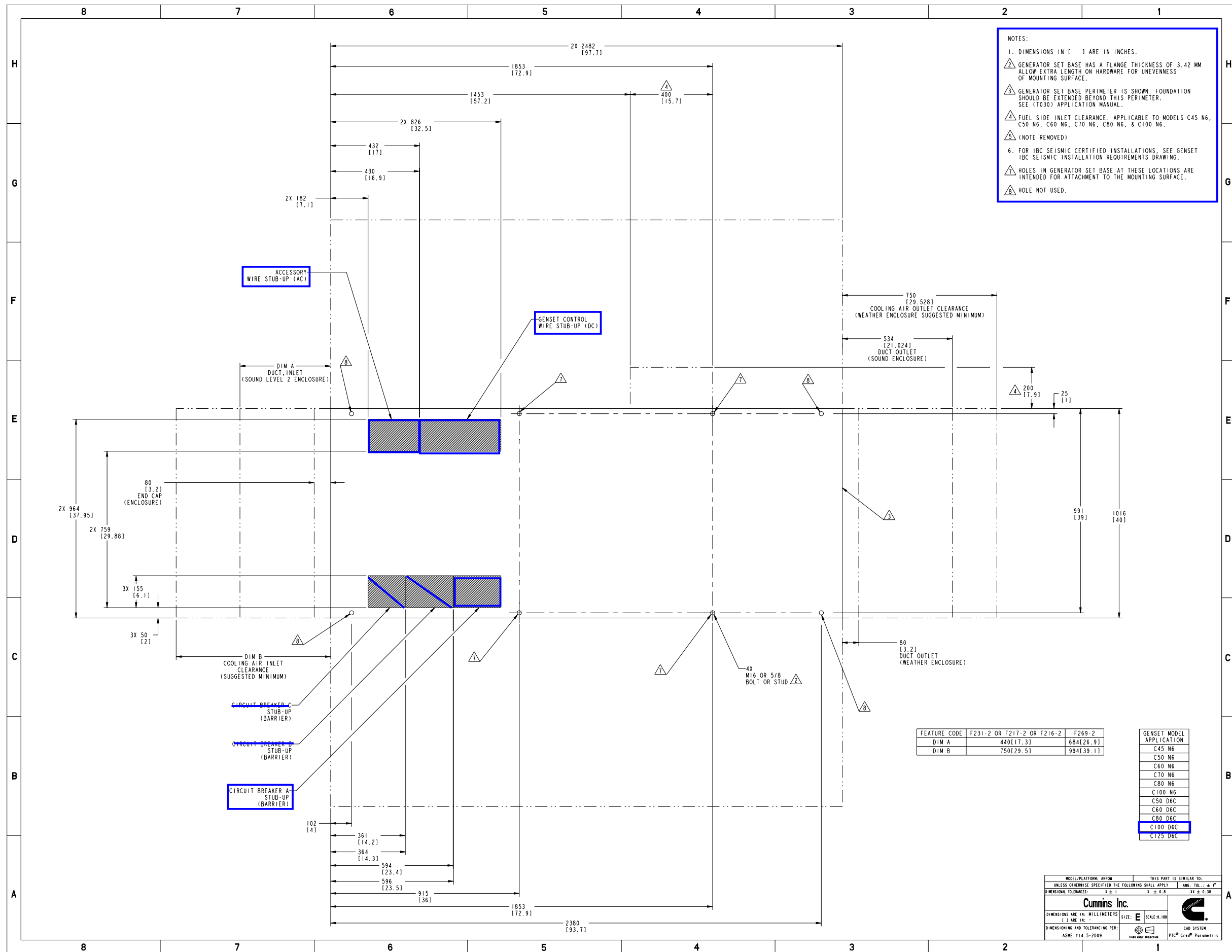

Document Generated: 13MAY2021 14:20 GMT



UNLESS OTHERWISE SPECIFIED,
ALL DIMENSIONS ARE IN INCHES

TOLERANCES:
FRACTIONAL: 1/4
XX: .06
XX: .03
XXX: .01
ANGLES: .5

REFERENCES
A054Y897
A051P365
A054B453

PREP. BY: KDU
CHKD. BY: -
MODIFIED BY: -
FINISH: N/A

ENGINE FAMILY:
OSB5 ENGINE
REGIONAL FUEL TANK

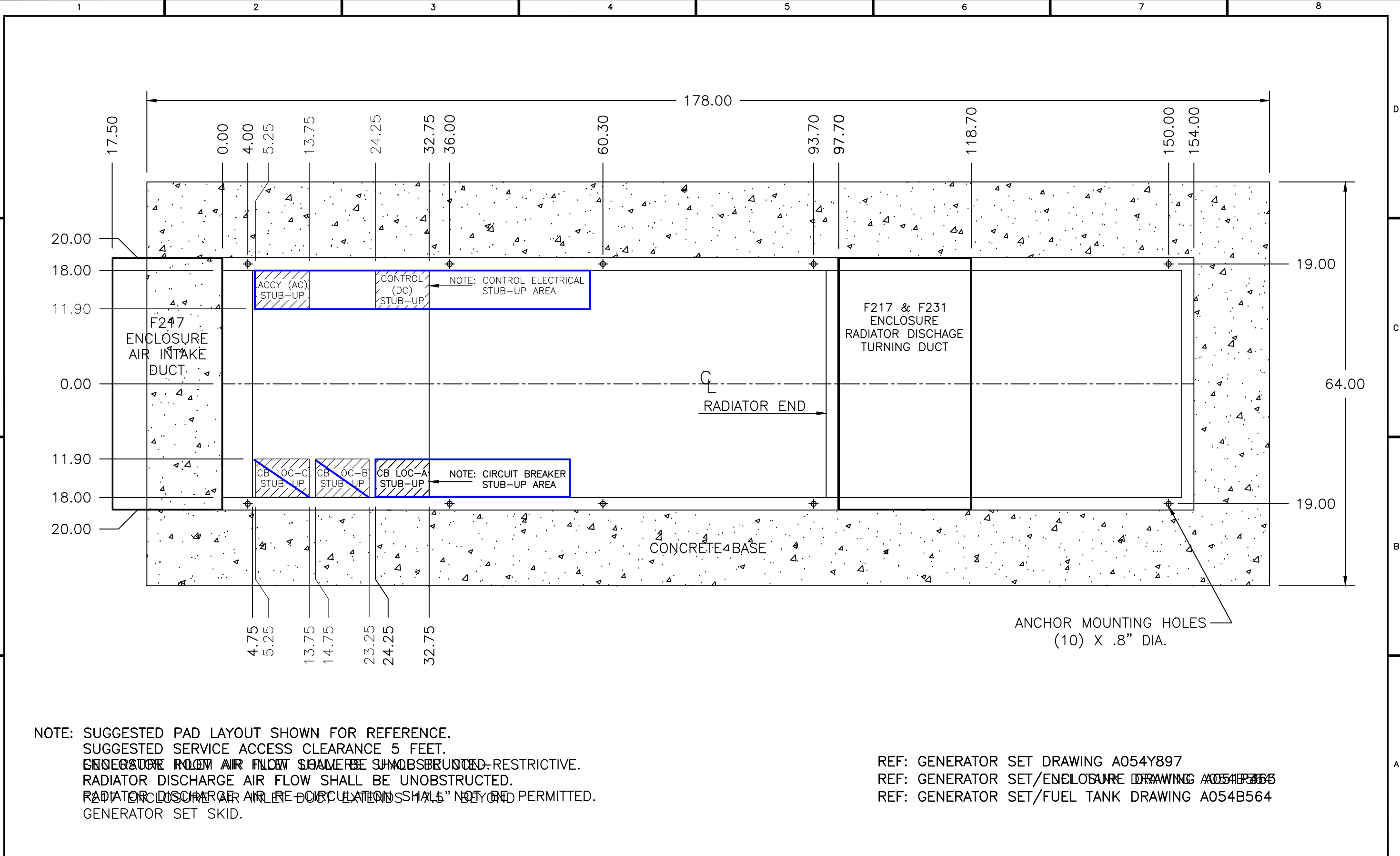

NOTE: SUGGESTED PAD LAYOUT SHOWN FOR REFERENCE.
SUGGESTED SERVICE ACCESS CLEARANCE 5 FEET.
ENCLOSURE ROOM AIR FLOW SHALL BE UNOBSTRUCTED-RESTRICTIVE.
RADIATOR DISCHARGE AIR FLOW SHALL BE UNOBSTRUCTED.
RADIATOR DISCHARGE AIR RE-CIRCULATION SHALL BE NOT PERMITTED.
GENERATOR SET SKID.

REF: GENERATOR SET DRAWING A054Y897
REF: GENERATOR SET/ENCLOSURE DRAWING A051P365
REF: GENERATOR SET/FUEL TANK DRAWING A054B564



SITE NAME:	CONTACT NAME:	CUSTOMER PROJECT NO:	TITLE: 50 KW THRU 125 KW DIESEL GENERATOR SET ENCLOSURE & REGIONAL FUEL TANK
CONTRACTOR NAME:	CONTACT NO:	CSSNA PROJECT NO:	SIZE: C DWG NO: C50 D6C THRU C125 D6C STUB-UP REV A
			SCALE: NONE DO NOT SCALE PRINT SHEET 1 OF 1

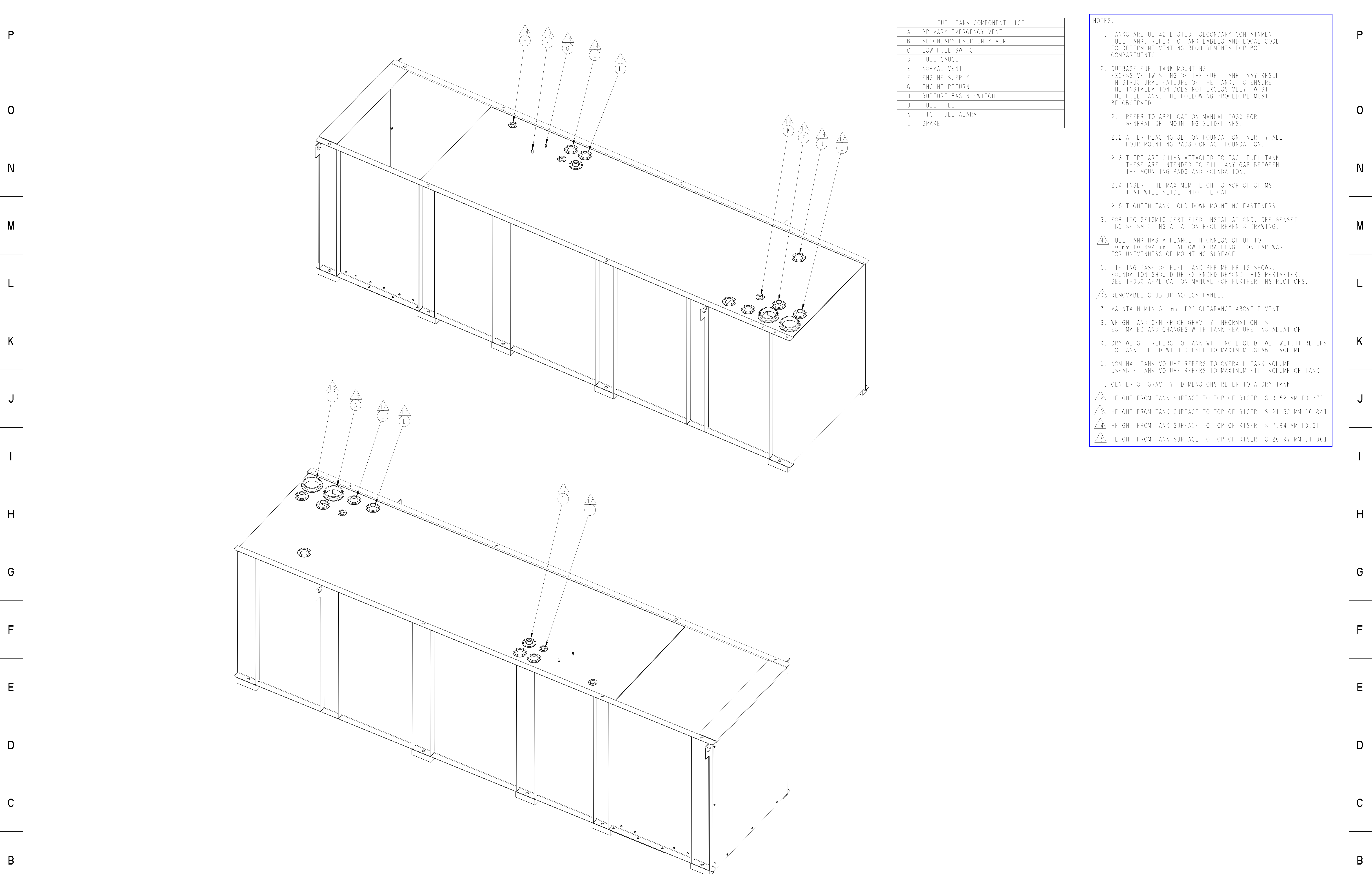

FUEL TANK COMPONENT LIST	
A	PRIMARY EMERGENCY VENT
B	SECONDARY EMERGENCY VENT
C	LOW FUEL SWITCH
D	FUEL GAUGE
E	NORMAL VENT
F	ENGINE SUPPLY
G	ENGINE RETURN
H	RUPTURE BASIN SWITCH
J	FUEL FILL
K	HIGH FUEL ALARM
L	SPARE

- NOTES:
- TANKS ARE UL142 LISTED. SECONDARY CONTAINMENT FUEL TANK. REFER TO TANK LABELS AND LOCAL CODE TO DETERMINE VENTING REQUIREMENTS FOR BOTH COMPARTMENTS.
 - SUBBASE FUEL TANK MOUNTING. EXCESSIVE TWISTING OF THE FUEL TANK MAY RESULT IN STRUCTURAL FAILURE OF THE TANK. TO ENSURE THE INSTALLATION DOES NOT EXCESSIVELY TWIST THE FUEL TANK, THE FOLLOWING PROCEDURE MUST BE OBSERVED:
 - REFER TO APPLICATION MANUAL T030 FOR GENERAL SET MOUNTING GUIDELINES.
 - AFTER PLACING SET ON FOUNDATION, VERIFY ALL FOUR MOUNTING PADS CONTACT FOUNDATION.
 - THERE ARE SHIMS ATTACHED TO EACH FUEL TANK. THESE ARE INTENDED TO FILL ANY GAP BETWEEN THE MOUNTING PADS AND FOUNDATION.
 - INSERT THE MAXIMUM HEIGHT STACK OF SHIMS THAT WILL SLIDE INTO THE GAP.
 - TIGHTEN TANK HOLD DOWN MOUNTING FASTENERS.
 - FOR IBC SEISMIC CERTIFIED INSTALLATIONS, SEE GENSET IBC SEISMIC INSTALLATION REQUIREMENTS DRAWING.
 - ⚠️ FUEL TANK HAS A FLANGE THICKNESS OF UP TO 10 mm [0.394 in]. ALLOW EXTRA LENGTH ON HARDWARE FOR UNEVENNESS OF MOUNTING SURFACE.
 - LIFTING BASE OF FUEL TANK PERIMETER IS SHOWN. FOUNDATION SHOULD BE EXTENDED BEYOND THIS PERIMETER. SEE T-030 APPLICATION MANUAL FOR FURTHER INSTRUCTIONS.
 - REMOVABLE STUB-UP ACCESS PANEL.
 - MAINTAIN MIN 51 mm [2] CLEARANCE ABOVE E-VENT.
 - WEIGHT AND CENTER OF GRAVITY INFORMATION IS ESTIMATED AND CHANGES WITH TANK FEATURE INSTALLATION.
 - DRY WEIGHT REFERS TO TANK WITH NO LIQUID. WET WEIGHT REFERS TO TANK FILLED WITH DIESEL TO MAXIMUM USEABLE VOLUME.
 - NOMINAL TANK VOLUME REFERS TO OVERALL TANK VOLUME. USEABLE TANK VOLUME REFERS TO MAXIMUM FILL VOLUME OF TANK.
 - CENTER OF GRAVITY DIMENSIONS REFER TO A DRY TANK.
 - ⚠️ HEIGHT FROM TANK SURFACE TO TOP OF RISER IS 9.52 MM [0.37]
 - ⚠️ HEIGHT FROM TANK SURFACE TO TOP OF RISER IS 21.52 MM [0.84]
 - ⚠️ HEIGHT FROM TANK SURFACE TO TOP OF RISER IS 7.94 MM [0.31]
 - ⚠️ HEIGHT FROM TANK SURFACE TO TOP OF RISER IS 26.97 MM [1.06]

PART NUMBER: A054B564	PART REVISION: H	Cummins Inc.	
PART NAME: OUTLINE.TANK			
DRAWING CATEGORY: OUTLINE		DIMENSIONS ARE IN: MILLIMETERS	SIZE: A0
STATE: RELEASED	SHEET: 1 OF 6	INCHES ARE IN:	SCALE: 1/8
CUMMINS DATA CLASSIFICATION: CUMMINS CONFIDENTIAL		DIMENSIONING AND TOLERANCING PER: ASME Y14.5-2009	
THIS DOCUMENT (AND THE INFORMATION SHOWN THEREON) IS CONFIDENTIAL AND PROPRIETARY AND SHALL NOT BE DISCLOSED TO OTHERS IN HARD COPY OR ELECTRONIC FORM, REPRODUCED BY ANY MEANS, OR USED FOR ANY PURPOSE WITHOUT WRITTEN CONSENT OF CUMMINS INC.			

270 GALLON FUEL TANK (A053L909)

TABULATION							
WEIGHT KG [LBS]		TANK VOLUME LITERS [GAL]		TANK HEIGHT MM [IN]		CENTER OF GRAVITY MM [IN]	
DRY	WET	NOMINAL	USEABLE	EXTERNAL	INTERNAL	CG X	CG Y
607 [1338]	1457 [3213]	1045 [276]	1022 [270]	558 [22]	458.7 [18.06]	2170 [85]	283 [11]

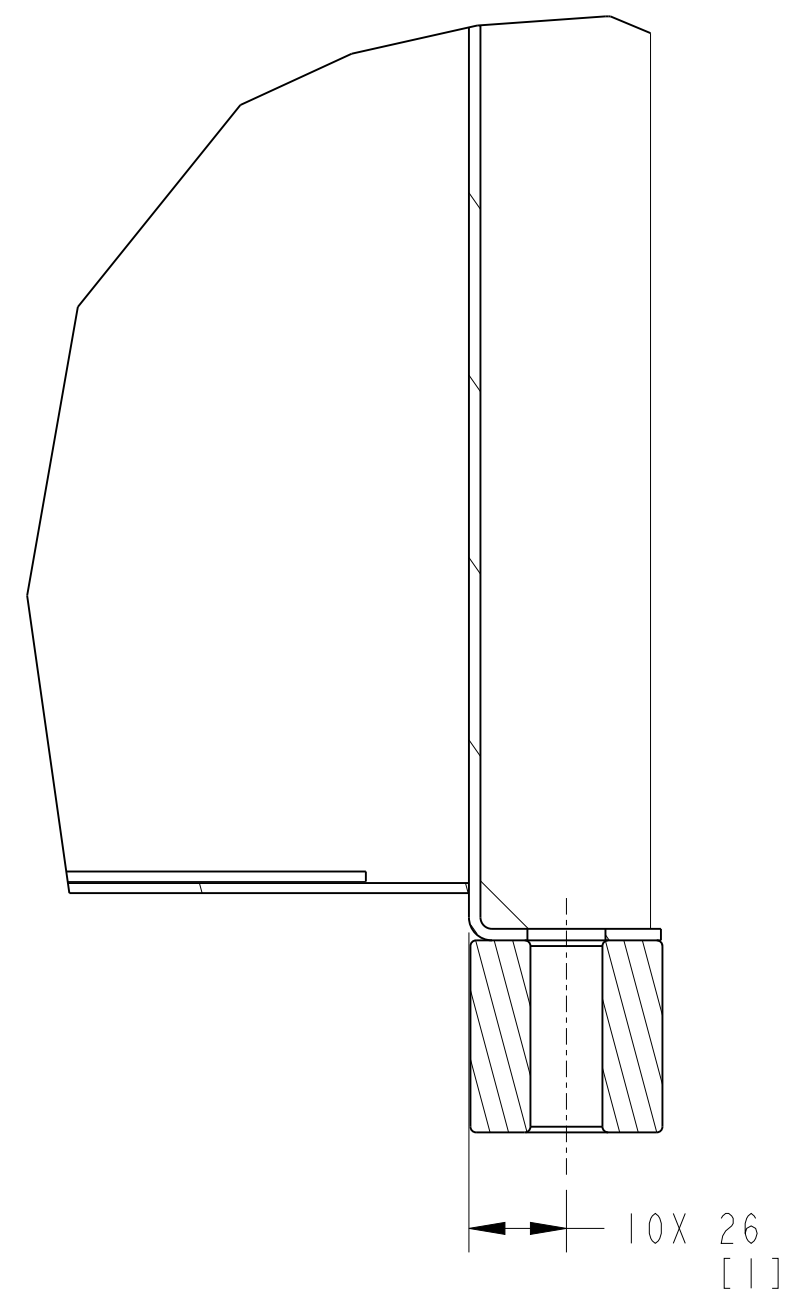

SECTION A-A
SCALE 1/2
VIEW FROM B

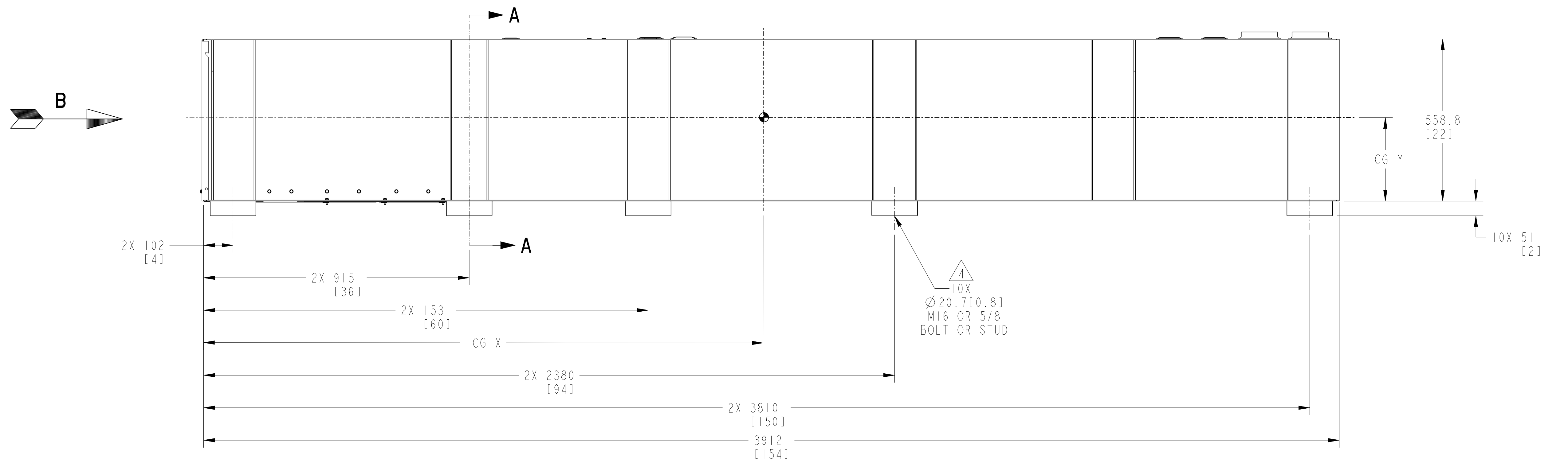
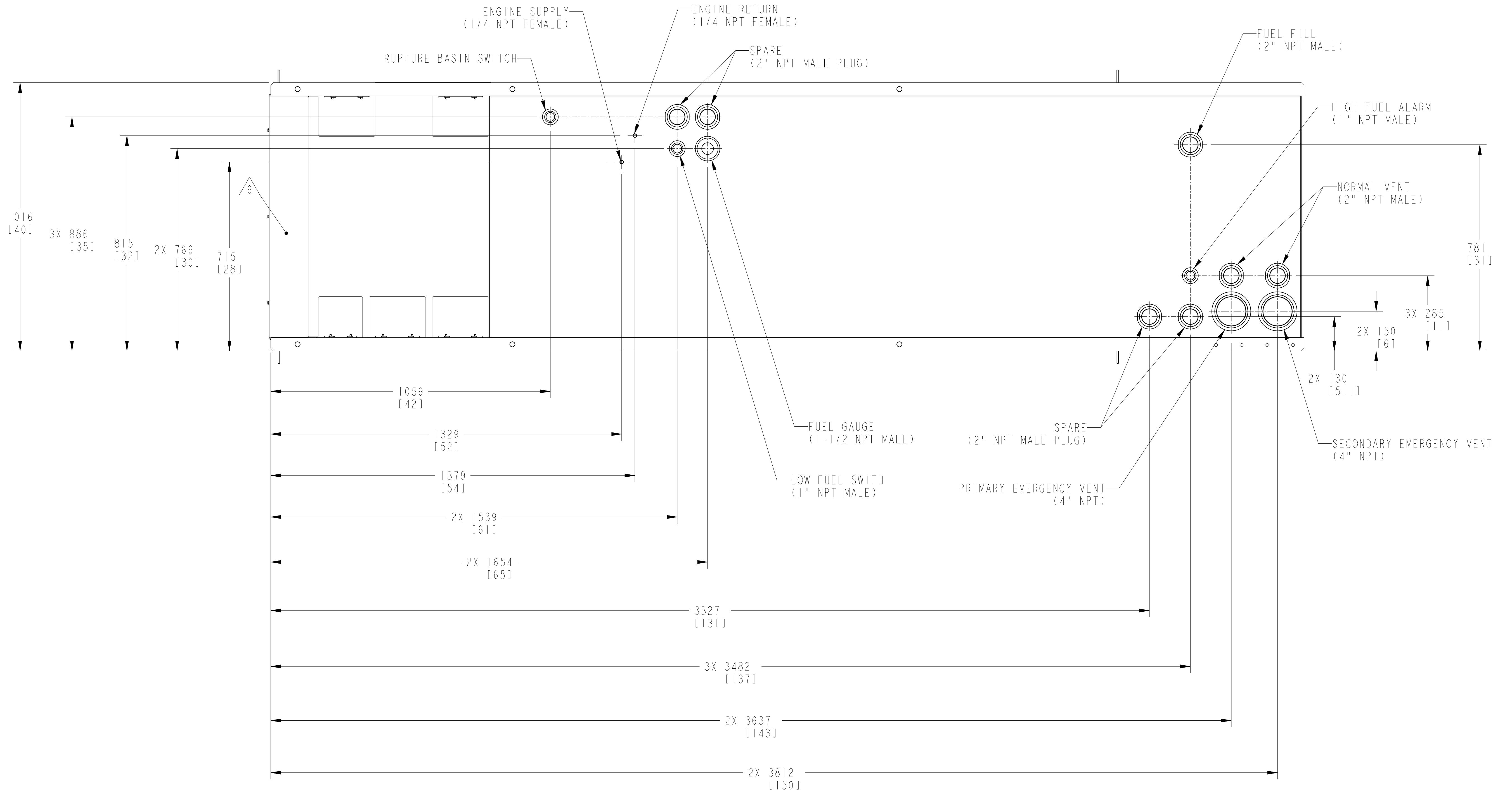
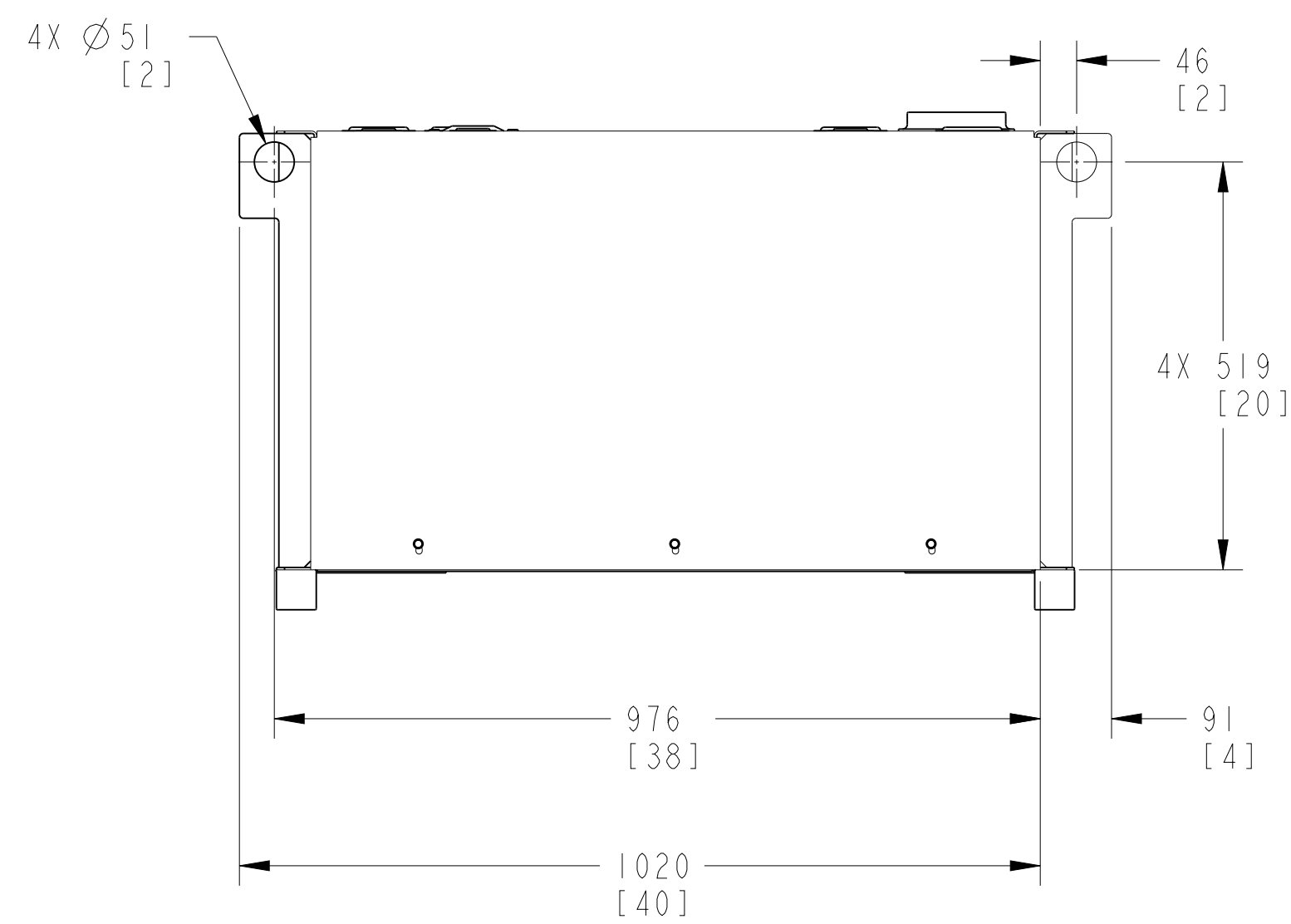

PART NUMBER: A054B564	PART REVISION: H	Cummins Inc.	DIMENSIONS ARE IN: MILLIMETERS INCHES ARE IN:	SIZE: A0 SCALE: 1/8	CAD SYSTEM PTC® Creo® Parametric
PART NAME: OUTLINE.TANK	DRAWING CATEGORY: OUTLINE				
STATE: RELEASED	SHEET: 2 OF 6	DIMENSIONING AND TOLERANCING PER: ASME Y14.5-2009			
CUMMINS DATA CLASSIFICATION: CUMMINS CONFIDENTIAL		THIS DOCUMENT (AND THE INFORMATION SHOWN THEREON) IS CONFIDENTIAL AND PROPRIETARY AND SHALL NOT BE DISCLOSED TO OTHERS IN HARD COPY OR ELECTRONIC FORM, REPRODUCED BY ANY MEANS, OR USED FOR ANY PURPOSE WITHOUT WRITTEN CONSENT OF CUMMINS INC.			

P
O
N
M
L
K
J
I
H
G
F
E
D
C
B
A

A053L909 TANK DEPTH CHART			
HEIGHT (IN)	HEIGHT (MM)	USABLE VOLUME (GAL.)	TOTAL VOLUME (GAL.)
0.5	12.7	0	8
2	50.8	23	31
4	101.6	55	61
6	152.4	86	92
8	203.2	116	122
10	254	147	153
12	304.8	177	183
14	355.6	208	214
16	406.4	239	244
18.06	458.7	270	276
20.3	515.62		310

A053L911 TANK DEPTH CHART			
HEIGHT (IN)	HEIGHT (MM)	USABLE VOLUME (GAL.)	TOTAL VOLUME (GAL.)
0.5	12.7	0	8
2	50.8	25	31
4	101.6	55	61
6	152.4	86	92
8	203.2	116	122
10	254	147	153
12	304.8	177	183
14	355.6	208	214
16	406.4	239	244
18	457.2	269	275
20	508	300	305
22	558.8	330	336
24	609.6	361	366
26	660.4	391	397
28	711.2	422	427
28.21	716.5	425	431
30.3	769.62		463

A053L912 TANK DEPTH CHART			
HEIGHT (IN)	HEIGHT (MM)	USABLE VOLUME (GAL.)	TOTAL VOLUME (GAL.)
0.5	12.7	0	8
2	50.8	25	31
4	101.6	55	61
6	152.4	86	92
8	203.2	116	122
10	254	147	153
12	304.8	177	183
14	355.6	208	214
16	406.4	239	244
18	457.2	269	275
20	508	300	305
22	558.8	330	336
24	609.6	361	366
26	660.4	391	397
28	711.2	422	427
30	762	452	458
32	812.8	483	489
34	863.6	513	519
36	914.4	544	550
38	965.2	574	580
40	1016	605	611
41.31	1049.3	625	631
44.3	1125.22		676

8

7

6

5

4

3

2

1

NOTES:

1. DIMENSIONS SHOWN IN [] ARE IN INCHES.

D

D

C

C

B

B

A

A

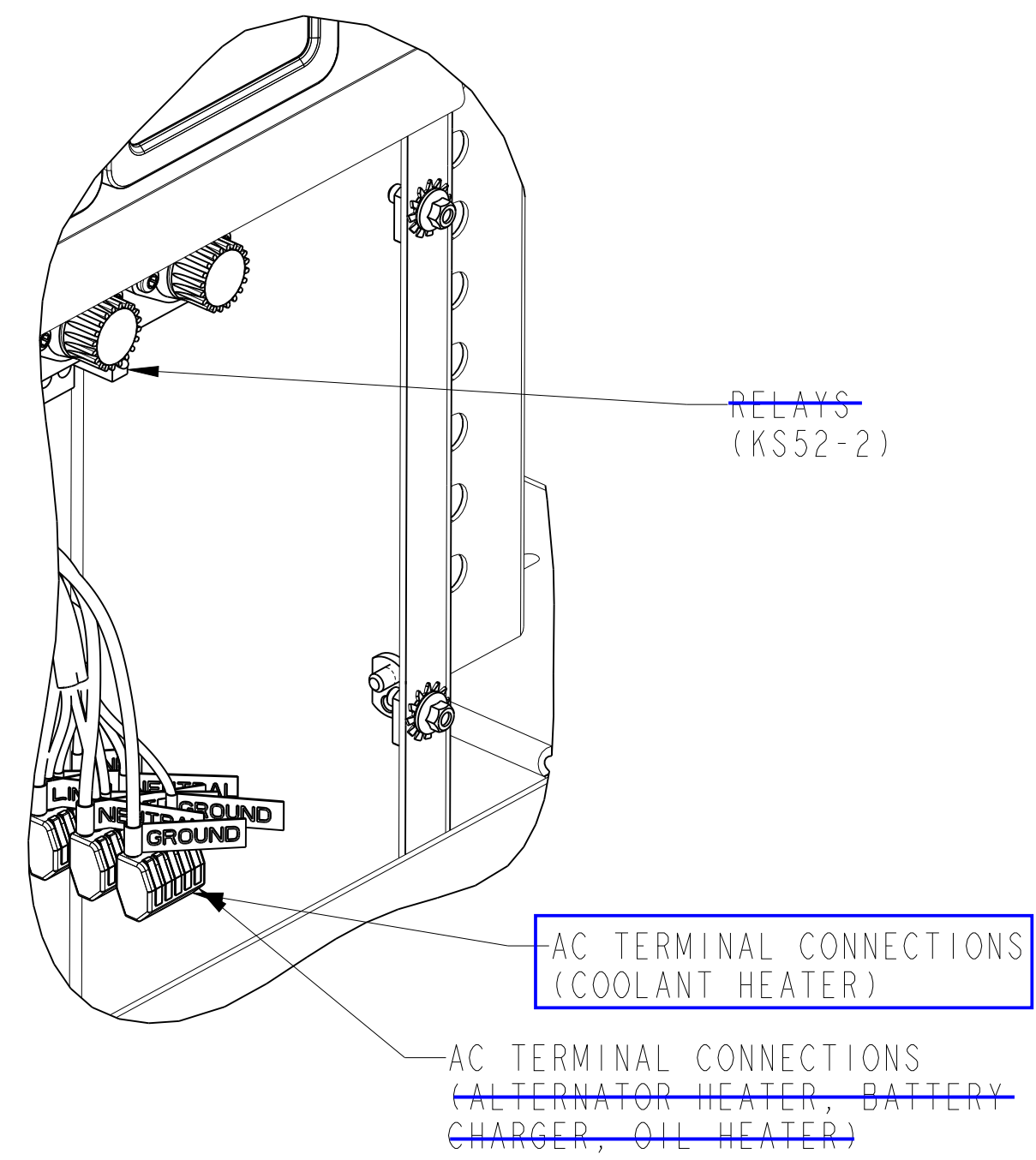
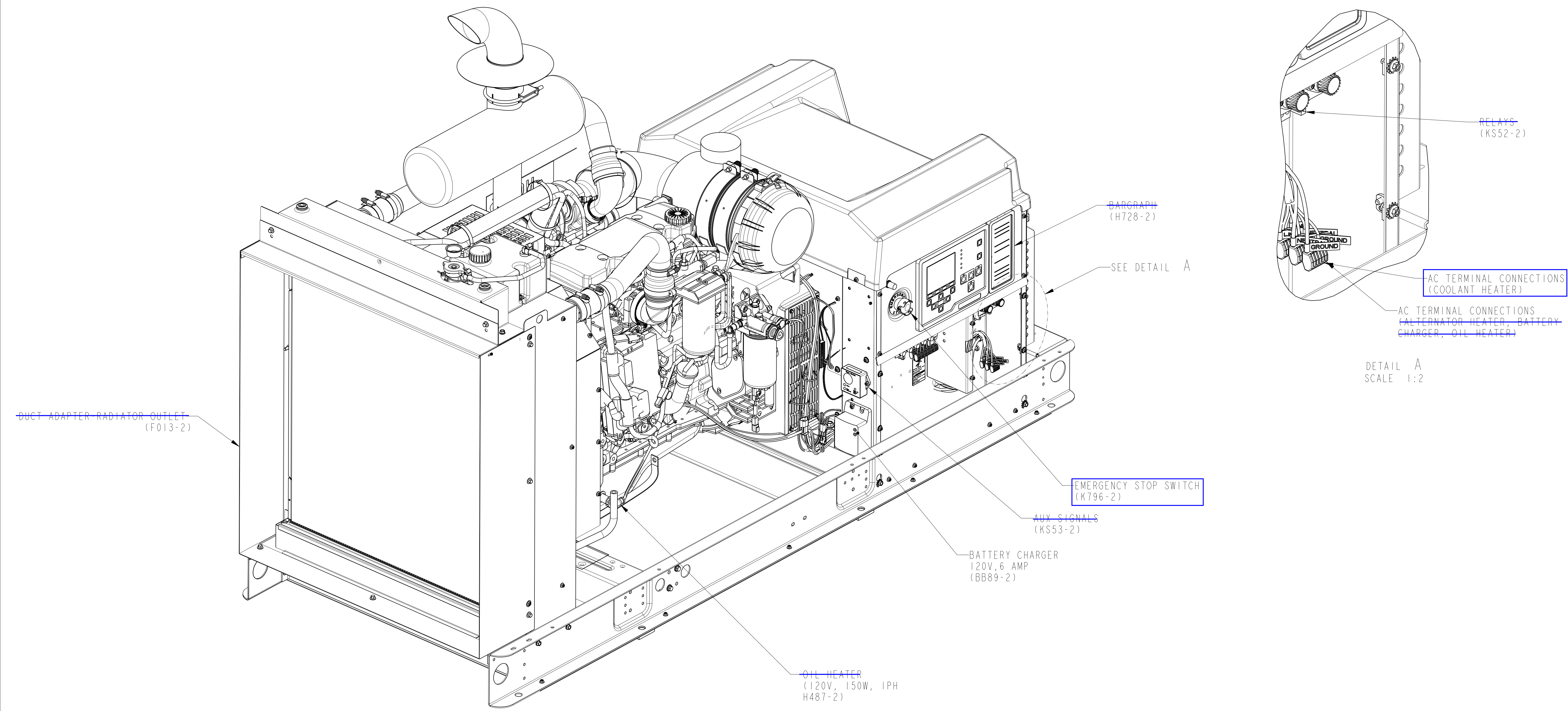

DETAIL A
SCALE 1:2

C50 D6C, C60 D6C, C80 D6C,
C100 D6C, C125 D6C

PART NUMBER: A054Y899	PART REVISION: E
PART NAME: OUTLINE, GENSET	
DRAWING CATEGORY: DETAIL	
STATE: RELEASED	SHEET: 1 OF 4
CUMMINS DATA CLASSIFICATION: CUMMINS INTERNAL USE ONLY	
THIS DOCUMENT (AND THE INFORMATION SHOWN THEREON) IS CONFIDENTIAL AND PROPRIETARY AND SHALL NOT BE DISCLOSED TO OTHERS IN HARD COPY OR ELECTRONIC FORM, REPRODUCED BY ANY MEANS, OR USED FOR ANY PURPOSE WITHOUT WRITTEN CONSENT OF CUMMINS INC.	

MODEL/PLATFORM: ARROW	THIS PART IS SIMILAR TO: NONE
Cummins Inc.	
DIMENSIONS ARE IN: MILLIMETERS [] ARE IN: -	SIZE: D SCALE: 3:16
DIMENSIONING AND TOLERANCING PER: ASME Y14.5-2009	THIRD ANGLE PROJECTION
 CAD SYSTEM PTC® Creo® Parametric	

8

7

6

5

4

3

2

1

8

7

6

5

4

3

2

1

D

D

C

C

B

B

A

A

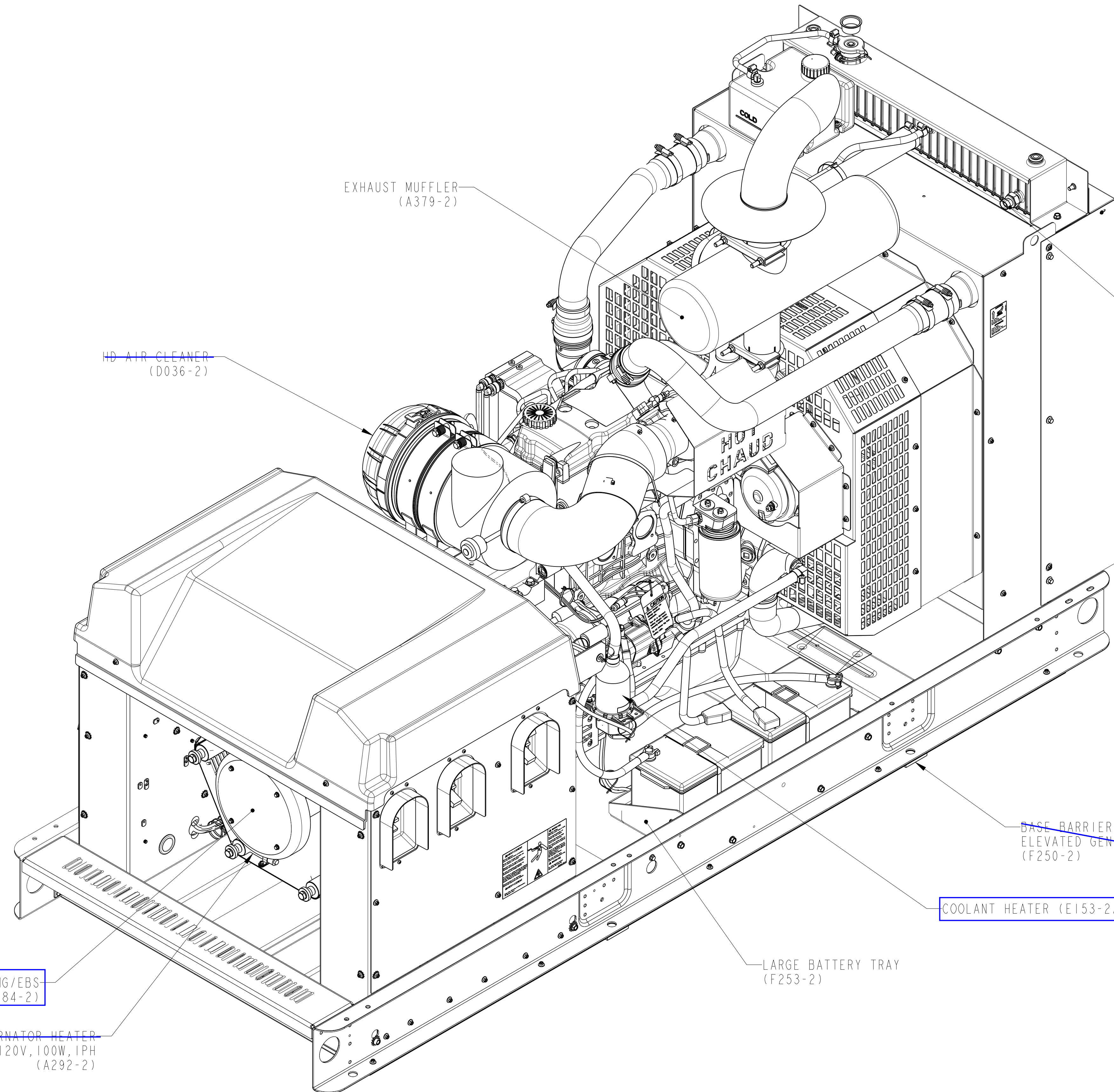

EXHAUST MUFFLER
(A379-2)

HD AIR CLEANER
(D036-2)

LOW COOLANT
SHUTDOWN/WARNING (SENSOR)
(H380-2/H527-2)

BASE BARRIER
ELEVATED GENSET
(F250-2)

COOLANT HEATER (E153-2/E154-2)

LARGE BATTERY TRAY
(F253-2)

EXCITER/REG-PMG/EBS
(B184-2)

ALTERNATOR HEATER
120V, 100W, 1PH
(A292-2)

C50 D6C, C60 D6C, C80 D6C,
C100 D6C, C125 D6C

PART NUMBER: A054Y899	PART REVISION: E
PART NAME: OUTLINE, GENSET	
DRAWING CATEGORY: DETAIL	
STATE: RELEASED	SHEET: 2 OF 4
CUMMINS DATA CLASSIFICATION: CUMMINS INTERNAL USE ONLY	
THIS DOCUMENT (AND THE INFORMATION SHOWN THEREON) IS CONFIDENTIAL AND PROPRIETARY AND SHALL NOT BE DISCLOSED TO OTHERS IN HARD COPY OR ELECTRONIC FORM, REPRODUCED BY ANY MEANS, OR USED FOR ANY PURPOSE WITHOUT WRITTEN CONSENT OF CUMMINS INC.	

Cummins Inc.		
DIMENSIONS ARE IN: MILLIMETERS () ARE IN: -	SIZE: D SCALE: 3:16	
DIMENSIONING AND TOLERANCING PER: ASME Y14.5-2009		 THIRD ANGLE PROJECTION
		CAD SYSTEM PTC® Creo® Parametric

8

7

6

5

4

3

2

1

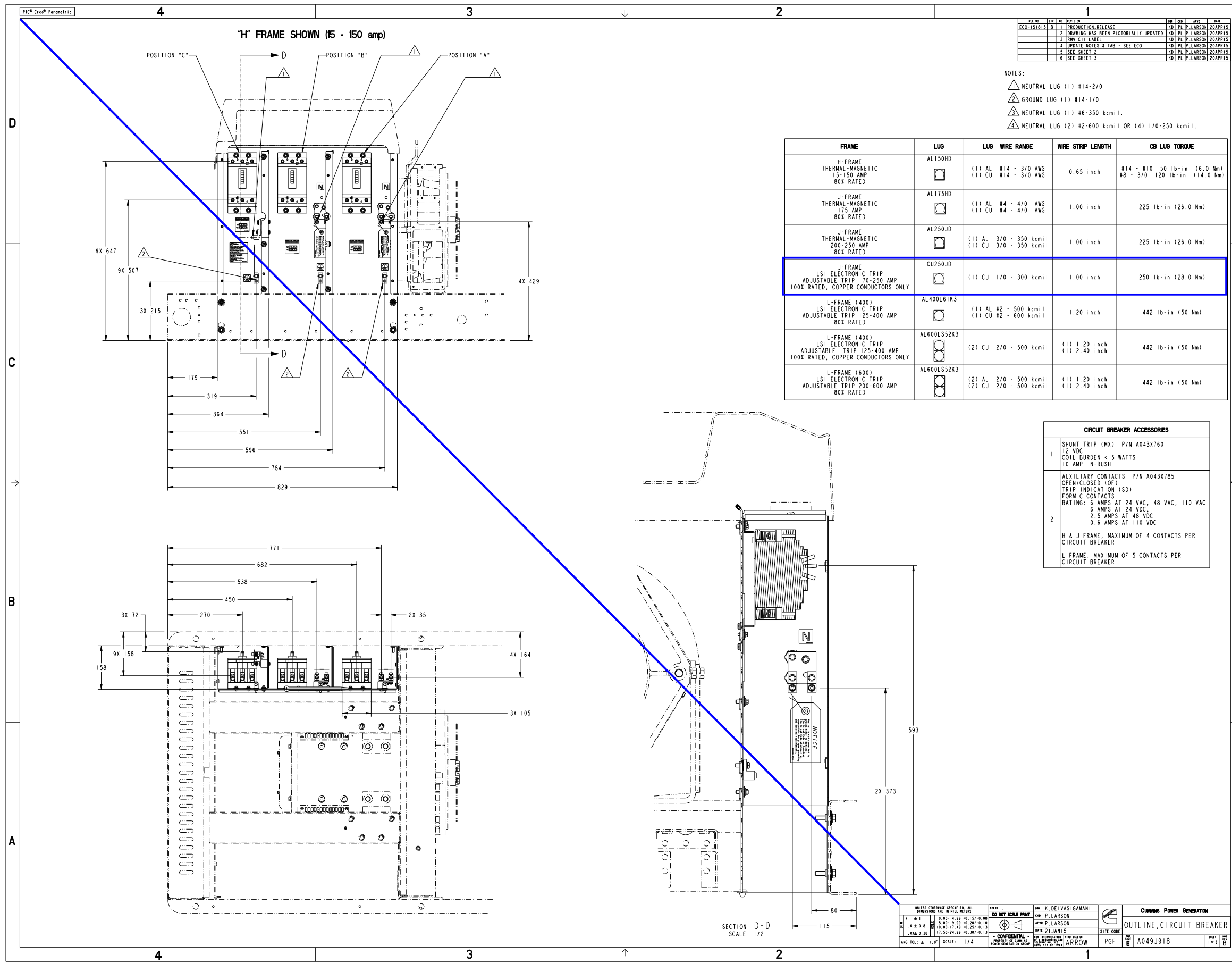

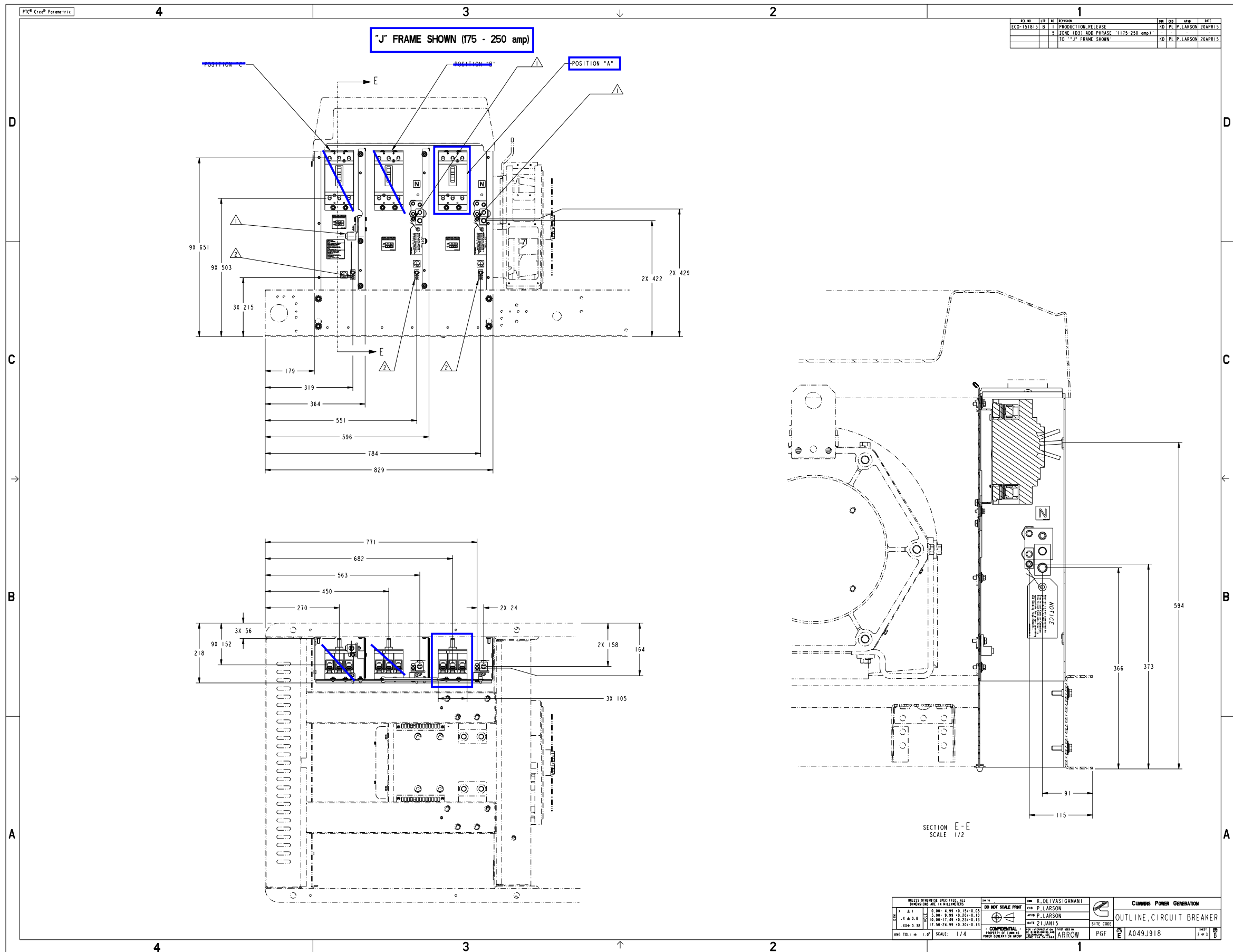

REV. NO.	DATE	DESCRIPTION	BY	CHKD.	DATE
ECO-151815	B	PRODUCTION RELEASE	RD FL P. LARSON	20APR15	
		5 ZONE (D3) ADD PHRASE "(175-250 amp)"			
		TO "'J' FRAME SHOWN"	RD FL P. LARSON	20APR15	

UNLESS OTHERWISE SPECIFIED, ALL DIMENSIONS ARE IN MILLIMETERS		K. DEIVASIGAMANI		CUMMINS POWER GENERATION	
DO NOT SCALE PRINT		P. LARSON		OUTLINE, CIRCUIT BREAKER	
DATE 21 JAN 15		SITE CODE		PGF	
ANG TOL: ± 1.0°		SCALE: 1/4		A049J918	
CONFIDENTIAL PROPERTY OF CUMMINS POWER GENERATION GROUP		ARROW		2 of 3	

AC ACCESSORY LOAD TABLE

CUSTOMER AC CONNECTION TERMINALS

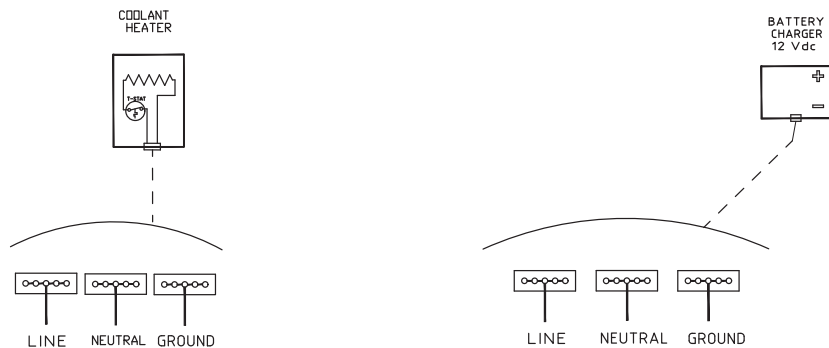

COOLANT HEATER 1000 WATTS, 120 VAC, 8.33 AMPS
 BATTERY CHARGER 192 WATTS, 120 VAC, 1.67 AMPS

NOTES:

1. INSTALLER TO PROVIDE BRANCH CIRCUITS TO POWER ALL ACCESSORIES
2. ALL ACCESSORIES ARE SINGLE PHASE 120/240 Vac 60 Hz
3. FOLLOW REGIONAL REGULATIONS AND APPLICABLE ELECTRIC CODES FOR INSTALLATION

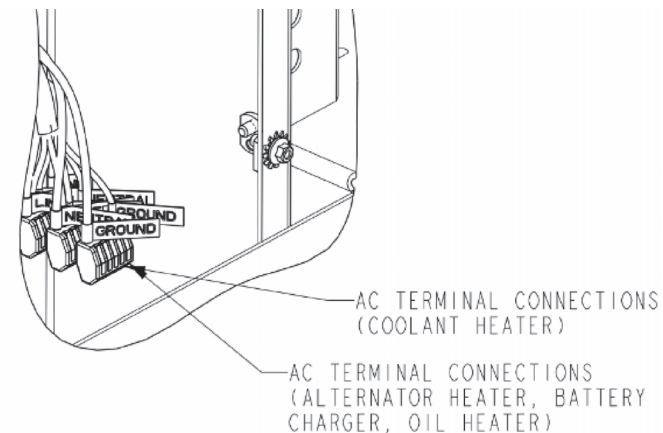

UNLESS OTHERWISE SPECIFIED,
 ALL DIMENSIONS ARE IN INCHES

PREP. BY: JPK 12/3/2024

SECTION 5

Warranty





Warranty Statement

Global Commercial Warranty Statement

Generator Set

Limited Warranty

Commercial Generating Set

This limited warranty applies to all Cummins Power Generation® branded commercial generating sets and associated accessories (hereinafter referred to as "Product").

This warranty covers any failures of the Product, under normal use and service, which result from a defect in material or factory workmanship.

Warranty Period:

The warranty start date[†] is the date of initial start up, first rental, demonstration or 18 months after factory ship date, whichever is sooner. See table for details.

Continuous Power (COP) is defined as being the maximum power which the generating set is capable of delivering continuously whilst supplying a constant electrical load when operated for an unlimited number of hours per year. No overload capability is available for this rating.

Prime Power (PRP) is defined as being the maximum power which a generating set is capable of delivering continuously whilst supplying a variable electrical load when operated for an unlimited number of hours per year. The permissible average power output over 24 hours of operation shall not exceed 70% of the PRP. For applications requiring permissible average output higher than stated, a COP rating should be used.

Limited-Time Running Power (LTP) is defined as the maximum power available, under the agreed operating conditions, for which the generating set is capable of delivering for up to 500 hours of operation per year.

Emergency Standby Power (ESP) is defined as the maximum power available during a variable electrical power sequence, under the stated operating conditions, for which a generating set is capable of delivering in the event of a utility power outage or under test conditions for up to 500 hours of operation per year. The permissible average power output over 24 hours of operation shall not exceed 70% of the ESP.

Environmental Protection Agency – Stationary Emergency (EPA-SE) is defined as being the maximum power available during a variable electrical power sequence, under the stated operating conditions, for which a generator set is capable of delivering in the event of a utility power outage or under test conditions and used in strict accordance with the EPA NSPS for stationary engines, 40 CFR part 60, subparts IIII and JJJJ, where a reliable utility must be present. The permissible average power output over 24 hours of operation shall not exceed 70% of the EPA-SE.

Data Center Continuous (DCC) is defined as the maximum power which the generator is capable of delivering continuously to a constant or varying electrical load for unlimited hours in a data center application.

**Base Warranty Coverage Duration
(Whichever occurs first)**

Rating	Months	Max. Hours
COP	12	Unlimited
PRP	12	Unlimited
LTP	12	500 hrs
ESP	24	1000 hrs
EPA-SE	24	Unlimited
DCC	24	Unlimited

[†] Warranty start date for designated rental and oil and gas model Products is determined to be date of receipt of Product by the end customer.

Cummins Power Generation® Responsibilities:

In the event of a failure of the Product during the warranty period due to defects in material or workmanship, Cummins Power Generation® will only be responsible for the following costs:

- All parts and labor required to repair the Product.
- Reasonable travel expenses to and from the Product site location.
- Maintenance items that are contaminated or damaged by a warrantable failure.

Owner Responsibilities:

The owner will be responsible for the following:

- Notifying Cummins Power Generation® distributor or dealer within 30 days of the discovery of failure.
- Installing, operating, commissioning and maintaining the Product in accordance with Cummins Power Generation®'s published policies and guidelines.
- Providing evidence for date of commissioning.
- Providing sufficient access to and reasonable ability to remove the Product from the installation in the event of a warrantable failure.
- Incremental costs and expenses associated with Product removal and reinstallation resulting from non-standard installations.
- Costs associated with rental of generating sets used to replace the Product being repaired.
- Costs associated with labor overtime and premium shipping requested by the owner.
- All downtime expenses, fines, all applicable taxes, and other losses resulting from a warrantable failure.

Limitations:

This limited warranty does not cover Product failures resulting from:

- Inappropriate use relative to designated power rating.
- Inappropriate use relative to application guidelines.
- Inappropriate use of an EPA-SE application generator set relative to EPA's standards.
- Normal wear and tear.
- Improper and/or unauthorized installation.
- Negligence, accidents or misuse.
- Lack of maintenance or unauthorized repair.
- Noncompliance with any Cummins Power Generation® published guideline or policy.
- Use of improper or contaminated fuels, coolants or lubricants.
- Improper storage before and after commissioning.
- Owner's delay in making Product available after notification of potential Product problem.
- Replacement parts and accessories not authorized by Cummins Power Generation®.
- Use of Battle Short Mode.
- Owner or operator abuse or neglect such as: operation without adequate coolant or lubricants; overfueling; overspeeding; lack of maintenance to lubricating, cooling or air intake systems; late servicing and maintenance; improper storage, starting, warm-up, run-in or shutdown practices, or for progressive damage resulting from a defective shutdown or warning device.

- Damage to parts, fixtures, housings, attachments and accessory items that are not part of the generating set.

This limited warranty does not cover costs resulting from:

- Difficulty in gaining access to the Product.
- Damage to customer property.

A "Data center" is defined as a dedicated facility that house computers and associated equipment for data storage and data handling.

Reliable utility is defined as utility power without routine or regularly scheduled black-outs.

Please contact your local Cummins Power Generation® Distributor for clarification concerning these limitations.

CUMMINS POWER GENERATION® RIGHT TO FAILED COMPONENTS:

Failed components claimed under warranty remain the property of Cummins Power Generation®. Cummins Power Generation® has the right to reclaim any failed component that has been replaced under warranty.

Extended Warranty:

Cummins Power Generation® offers several levels of Extended Warranty Coverage. Please contact your local Cummins Power Generation® Distributor for details.

www.power.cummins.com

THE WARRANTIES SET FORTH HEREIN ARE THE SOLE WARRANTIES MADE BY CUMMINS POWER GENERATION® IN REGARD TO THE PRODUCT. CUMMINS POWER GENERATION® MAKES NO OTHER WARRANTIES, EXPRESS OR IMPLIED, OR OF MERCHANTABILITY OR FITNESS FOR A PARTICULAR PURPOSE.

IN NO EVENT IS CUMMINS POWER GENERATION® LIABLE FOR INCIDENTAL OR CONSEQUENTIAL DAMAGES.

This limited warranty shall be enforced to the maximum extent permitted by applicable law. This limited warranty gives the owner specific rights that may vary from state to state or from jurisdiction to jurisdiction.

Product Model Number: _____
 Product Serial Number: _____
 Date in Service: _____

power.cummins.com

Copyright © 2017 Cummins Inc. All rights reserved.

Cummins, the “C” logo, PowerCommand, AmpSentry, and InPower are trademarks of Cummins Inc.

Other company, product, or service names may be trademarks or service marks of others.

Specifications are subject to change without notice.





GAS SUPPLY DESIGN BEST PRACTICES

Required:

1. The required fuel pressure and volume **must** be available under **all** operating conditions at the generator set gas inlet (see Location A on Figure 1 for measurement point).
2. The generator must have a dedicated pipe run from the meter, not teed off from other equipment supply pipes.
3. Braided flex piping and dry gas filters are required elements of the piping design, but if improperly sized can be highly restrictive to flow. These components and other restrictive portions of the piping system (valves, elbows, etc.) can, and often should be sized larger than the genset fuel connection.
4. A 'pilot' style regulator should never be used, as they are slow to respond to changes in demand from the generator set.

Recommended:

1. Long pipe runs increase pressure drop, so shorter is better. Elbows & valves increase restriction to flow, piping should be designed with as few of these as possible.
2. It is important to have the final pressure regulator as close to the generator inlet as practical. This allows for higher pressure in the line, as well as helps keep a steady draw on the line during operation.

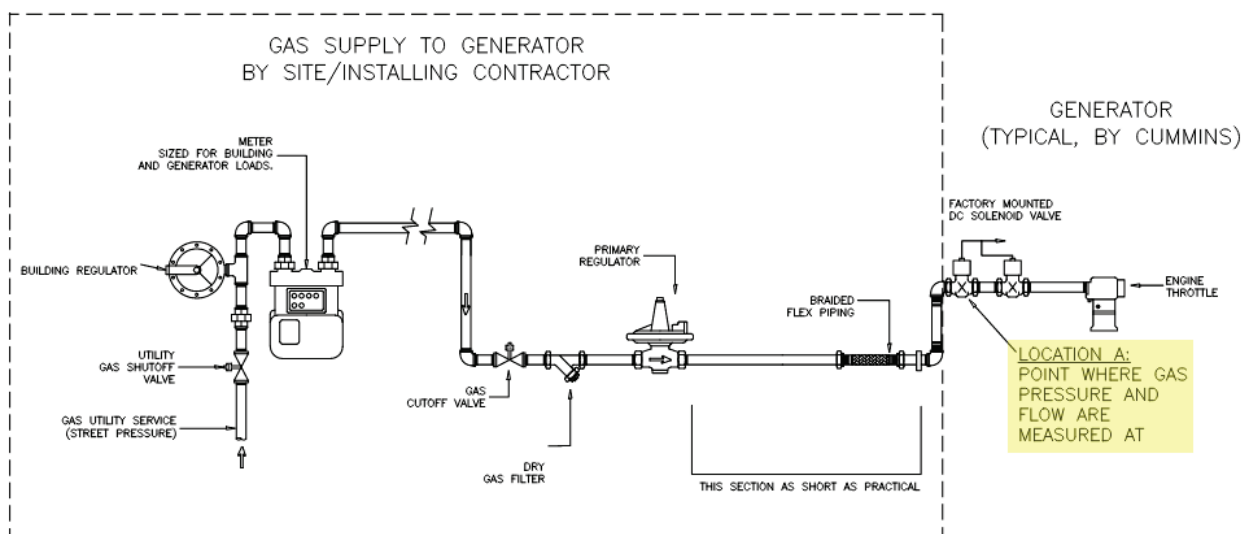

Figure 1. Typical site design



All gas supply piping must be designed by the appropriate engineer and installed by a qualified contractor. Refer to **NFPA 54** for gas pipe sizing information and any related local jurisdiction documents for code compliance on fuel piping installation.

Gas Fuel supply requirements for this generator set:

Fuel source:

NG

PV

Fuel consumption at 100% load: SCFH

Required Operating fuel pressure: in H₂O

Pressure is measured at the engine inlet solenoid, after the final regulator

Please note: The pressure listed is not a static pressure. If the above pressure is not maintained while the generator set is operating up to full load, the system will not function as required and the fuel delivery system will need to be corrected to provide operating pressure as listed.

All generators must be installed with a flexible fuel line and fuel strainer prior to the engine connection (**installation by others**):

Provided by Cummins

Provided by others

Flexible fuel line:

Fuel strainer:

Pressure regulator:

If provided by Cummins, see drawings in submittal for flex line and strainer sizing

Contact your Cummins representative for technical assistance.

TABLE OF CONTENTS



Section 1 - Project Information

Project Bill of Material
Gas Submittal Insert

Section 2 - Generator Specification Sheets

Generator Specification Sheet (C25N6)
Generator Data Sheet
PowerCommand Control (PCC) Specification Sheet
Alternator Data Sheet
Sound Data Sheet
Cooling System Data Sheet
Exhaust Emission Compliance Statement
Exhaust Emission Data Sheet
Prototype Test Summary Report
IBC Seismic Certificate of Compliance Specification Sheet

Section 3 - Generator Accessories

Circuit Breaker Data Sheet
Enclosure Kit-Polymer Sandstone SL1 to SL2 (A043J733)
Battery Charger Specification Sheet
Fuel Accessories Specification Sheet

Section 4 - Generator Drawings and Interconnects

Enclosure Outline Drawing
Generator Outline Drawing
Foundation Outline Drawing
Generator Options Outline Drawing
Circuit Breaker Outline Drawing
AC Interconnection Wiring Diagram
IBC Seismic Installation Requirements

Section 5 - Warranty

Generator Warranty Statement

SECTION 2

Generator Specifications





Spark-ignited generator set

20-40 kW Standby

EPA emissions



Description

Cummins® generator sets are fully integrated power generation systems providing optimum performance, reliability and versatility for stationary Standby applications.

Features

Gas engine - Rugged 4-cycle Cummins QSJ2.4 spark-ignited engine delivers reliable power. The electronic air/fuel ratio control provides optimum engine performance and fast response to load changes.

Alternator - Several alternator sizes offer selectable motor starting capability with low reactance 2/3 pitch windings, low waveform distortion with non-linear loads and fault clearing short-circuit capability.

Control system - The PowerCommand® 1.1 electronic control is standard equipment and provides total generator set system integration including automatic remote starting/stopping, precise frequency and voltage regulation, alarm and status message display, output metering, auto-shutdown at fault detection and NFPA 110 Level 1 compliance.

Cooling system - Standard cooling package provides reliable running at up to 50° C (122° F) ambient temperature.

Enclosures - The aesthetically appealing enclosure incorporates special designs that deliver one of the quietest generators of its kind. Aluminium material plus durable powder coat paint provides the best anti-corrosion performance. **The generator set enclosure has been evaluated to withstand 180 MPH wind loads in accordance with ASCE7-10.** The intelligent design has removable panels and service doors to provide easy access for service and maintenance.

NFPA - The generator set accepts full rated load in a single step in accordance with NFPA 110 for Level 1 systems.

Warranty and service - Backed by a comprehensive warranty and worldwide distributor network.

Model	Natural gas		Propane		Data sheets 60 Hz
	Standby 60 Hz		Standby 60 Hz		
	kW	kVA	kW	kVA	
C20 N6	20	25	20	25	NAD-5693-EN
C25 N6	25	31	25	31	NAD-5695-EN
C30 N6	30	38	30	38	NAD-5696-EN
C36 N6	36	45	36	45	NAD-5697-EN
C40 N6	40	50	40	50	NAD-5698-EN

Generator set specifications

Governor regulation class	ISO8528 Part 1 Class G3*
Voltage regulation, no load to full load	± 1.0%
Random voltage variation	± 1.0%
Frequency regulation	Isochronous
Random frequency variation	± 0.25% @ 60 Hz
Radio frequency emissions compliance	Meets requirements of most industrial and commercial applications

* C36 N6 and C40 N6 are Class G2

Engine specifications

Aspiration	Naturally Aspirated (25kW), Turbocharged (30kW), Turbocharged and Aftercooled (36kW/40kW)
Bore	86.5 mm (3.4 in.)
Stroke	100.0 mm (3.94 in.)
Displacement	2.4 L (143.5 in ³)
Cylinder block	Cast iron, in-line 4 cylinder
Battery capacity	550 amps at ambient temperature of 0° F to 32° F (-18° C to 0° C)
Battery charging alternator	50 amps
Starting voltage	12 volt, negative ground
Lube oil filter type(s)	Spin-on with relief valve
Standard cooling system	50° C (122° F) ambient cooling system
Rated speed	1800 rpm

Alternator specifications

Design	Brushless, 4 pole, drip proof, revolving field
Stator	2/3 pitch
Rotor	Direct coupled, flexible disc
Insulation system	Class H per NEMA MG1-1.65
Standard temperature rise	120° C (248° F) Standby
Exciter type	Torque match (shunt) with EBS as option
Alternator cooling	Direct drive centrifugal blower
AC waveform Total Harmonic Distortion (THDV)	< 5% no load to full linear load, < 3% for any single harmonic
Telephone Influence Factor (TIF)	< 50 per NEMA MG1-22.43
Telephone Harmonic Factor (THF)	< 3%

Available voltages

1-phase	3-phase			
• 120/240	• 120/208	• 120/240 delta	• 277/480	• 347/600

Generator set options

Fuel system

- **Single fuel - natural gas or propane vapor, field selectable**
- Dual fuel – natural gas and propane vapor auto changeover
- Low fuel gas pressure warning

Engine

- **Engine air cleaner – normal** or heavy **duty**
- **Shut down – low oil pressure**
- **Extension – oil drain**

Alternator

- **120° C (248° F) temperature rise alternator**
- 105° C (221° F) temperature rise alternator
- PMG available on 36 kW and 40 kW
- Alternator heater, 120 V

Control

- AC output analog meters (bargraph)
- Stop switch – emergency
- Auxiliary output relays (2)
- Auxiliary configurable signal inputs (8) and relay outputs (8)

Electrical

- **Single circuit breaker**
- Dual circuit breakers
- **80% rated circuit breakers**
- 100% rated circuit breakers

Enclosure

- **Aluminium enclosure Sound Level 1** or Level 2, **with muffler installed, sandstone** or green color
- Open set

Cooling system

- **Shutdown – low coolant level**
- Warning – low coolant level
- **Extension – coolant drain**
- **Cold weather options:**
 - < 4° C (40° F) – cold weather
 - < -17° C (0° F) – extreme cold weather

Exhaust system

- Exhaust connector NPT

Generator set application

- Base barrier – elevated generator set
- **Battery rack, larger battery**
- Radiator outlet duct adapter

Generator set options (continued)

Warranty

- Base warranty – 2 year, 1000 hour, Standby
- Standby, 3 year, 1500 hour, parts
- Standby, 5 year, 2500 hour, parts
- Standby, 3 year, 1500 hour, parts and labor
- Standby, 5 year, 2500 hour, parts and labor
- Standby, 3 year, 1500 hour, parts, labor and travel
- Standby, 5 year, 2500 hour, parts, labor and travel

Note: Some options may not be available on all models - consult factory for availability.

Generator set accessories

- Extreme cold weather kit
- Battery rack, larger battery
- Battery heater kit
- HMI211RS in-home display, including pre-configured 12-inch harness
- HMI211 remote display, including pre-configured 12-inch harness
- HMI220 remote display
- Auxiliary output relays (2)
- Auxiliary configurable signal inputs (8) and relay outputs (8)
- Annunciator – RS485
- Remote monitoring device – Acumen®
- Battery charger – stand-alone, 12 V
- Circuit breakers
- Enclosure Sound Level 1 to Sound Level 2 upgrade kit
- Enclosure paint touch up kit
- Base barrier – elevated generator set
- Mufflers – industrial, residential or critical
- PMG available on 36 kW and 40 kW
- Alternator heater
- Maintenance and service kit
- Engine lift kit

Control system PowerCommand 1.1



PowerCommand control is an integrated generator set control system providing voltage regulation, engine protection, operator interface and isochronous governing (optional). Major features include:

- Battery monitoring and testing features and smart starting control system.
- Standard PCCNet interface to devices such as remote annunciator for NFPA 110 applications.
- Control boards potted for environmental protection.
- Control suitable for operation in ambient temperatures from -40 °C to +70 °C (-40 °F to +158 °F) and altitudes to 5000 meters (13,000 feet).
- Prototype tested; UL, CSA, and CE compliant.
- InPower™ PC-based service tool available for detailed diagnostics.

Operator/display panel

- Manual off switch
- Alpha-numeric display with pushbutton access for viewing engine and alternator data and providing setup, controls and adjustments (English or international symbols)
- LED lamps indicating generator set running, not in auto, common warning, common shutdown, manual run mode and remote start
- Suitable for operation in ambient temperatures from -40 °C to +70 °C
- Bargraph display (optional)

AC protection

- Over current warning and shutdown
- Over and under voltage shutdown
- Over and under frequency shutdown
- Over excitation (loss of sensing) fault
- Field overload

Engine protection

- Overspeed shutdown
- Low oil pressure warning and shutdown
- High coolant temperature warning and shutdown
- Low coolant level warning or shutdown
- Low coolant temperature warning
- High, low and weak battery voltage warning
- Fail to start (overcrank) shutdown
- Fail to crank shutdown
- Redundant start disconnect
- Cranking lockout
- Sensor failure indication
- Low fuel level warning or shutdown

Alternator data

- Line-to-Line and Line-to-Neutral AC volts
- 3-phase AC current
- Frequency
- Total kVa

Engine data

- DC voltage
- Lube oil pressure
- Coolant temperature
- Engine speed

Other data

- Generator set model data
- Start attempts, starts, running hours
- Fault history
- RS485 Modbus® interface
- Data logging and fault simulation (requires InPower service tool)

Digital governing (optional)

- Integrated digital electronic isochronous governor
- Temperature dynamic governing

Digital voltage regulation

- Integrated digital electronic voltage regulator
- 2-phase Line-to-Line sensing
- Configurable torque matching

Control functions

- Time delay start and cooldown
- Cycle cranking
- PCCNet interface
- (2) Configurable inputs
- (2) Configurable outputs
- Remote emergency stop
- Automatic Transfer Switch (ATS) control
- Generator set exercise, field adjustable

Options

- Auxiliary output relays (2)
- Remote annunciator with (3) configurable inputs and (4) configurable outputs
- PMG alternator excitation available on 36 kW and 40 kW
- Acumen® telematics for remote monitoring and control via Cummins PowerCommand Cloud
- Auxiliary, configurable signal inputs (8) and configurable relay outputs (8)
- **Digital governing**
- AC output analog meters (bargraph)
 - Color-coded graphical display of:
 - 3-phase AC voltage
 - 3-phase current
 - Frequency
 - kVa
- Remote operator panel

Ratings definitions

Emergency Standby Power (ESP):

Applicable for supplying power to varying electrical load for the duration of power interruption of a reliable utility source. Emergency Standby Power (ESP) is in accordance with ISO 8528. Fuel Stop power in accordance with ISO 3046, AS 2789, DIN 6271 and BS 5514.

Limited-Time Running Power (LTP):

Applicable for supplying power to a constant electrical load for limited hours. Limited-Time Running Power (LTP) is in accordance with ISO 8528.

Prime Power (PRP):

Applicable for supplying power to varying electrical load for unlimited hours. Prime Power (PRP) is in accordance with ISO 8528. Ten percent overload capability is available in accordance with ISO 3046, AS 2789, DIN 6271 and BS 5514.

Base Load (Continuous) Power (COP):

Applicable for supplying power continuously to a constant electrical load for unlimited hours. Continuous Power (COP) in accordance with ISO 8528, ISO 3046, AS 2789, DIN 6271 and BS 5514.

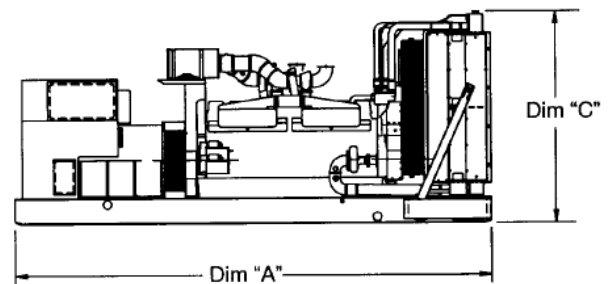
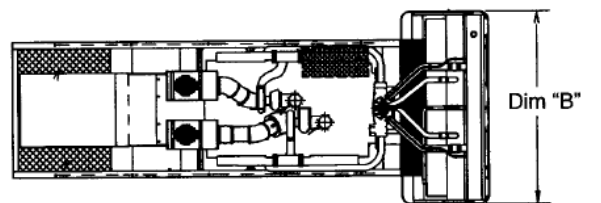

This outline drawing is for reference only. See respective model data sheet for specific model outline drawing number.

Do not use for installation design





Model	Dim "A" mm (in.)	Dim "B" mm (in.)	Dim "C" mm (in.)	Set weight* dry kg (lbs)	Set weight* wet kg (lbs)
Open set					
C20 N6	1669 (65.7)	864 (34)	1123 (44.2)	423 (933)	440 (969)
C25 N6	1669 (65.7)	864 (34)	1123 (44.2)	441 (972)	457 (1008)
C30 N6	2225 (87.6)	864 (34)	1123 (44.2)	491 (1083)	508 (1119)
C36 N6	2225 (87.6)	864 (34)	1123 (44.2)	520 (1146)	536 (1182)
C40 N6	2225 (87.6)	864 (34)	1123 (44.2)	548 (1208)	564 (1244)
Sound attenuated enclosure Level 1					
C20 N6	1829 (72)	864 (34)	1156 (45.5)	469 (1034)	485 (1070)
C25 N6	1829 (72)	864 (34)	1156 (45.5)	477 (1073)	503 (1109)
C30 N6	2388 (94)	864 (34)	1156 (45.5)	522 (1195)	558 (1231)
C36 N6	2388 (94)	864 (34)	1156 (45.5)	571 (1258)	587 (1294)
C40 N6	2388 (94)	864 (34)	1156 (45.5)	599 (1320)	615 (1356)
Sound attenuated enclosure Level 2					
C20 N6	2073 (81.6)	864 (34)	1156 (45.5)	474 (1045)	490 (1081)
C25 N6	2073 (81.6)	864 (34)	1156 (45.5)	492 (1084)	508 (1120)
C30 N6	2626 (103.4)	864 (34)	1156 (45.5)	547 (1206)	563 (1242)
C36 N6	2626 (103.4)	864 (34)	1156 (45.5)	576 (1269)	592 (1305)
C40 N6	2626 (103.4)	864 (34)	1156 (45.5)	604 (1331)	620 (1367)

Refer to drawings for specific weights and dimensions

* Weights based on 1-phase generator set. Weights may vary with a different configuration.

Codes and standards

Codes or standards compliance may not be available with all model configurations – consult factory for availability.

ISO 9001 ISO 14001 ISO 45001	This product was manufactured in a facility whose quality management system is certified to ISO 9001 and its Health Safety Environmental Management Systems certified to ISO 14001 and ISO 45001.		This product is listed to UL 2200, Stationary Engine Generator Assemblies
	The Prototype Test Support (PTS) program verifies the performance integrity of the generator set design. Cummins products bearing the PTS symbol meet the prototype test requirements of NFPA 110 for Level 1 systems.		Engine certified to U.S. EPA SI Stationary Emission Regulation 40 CFR, Part 60. U.S. applications must be applied per this EPA regulation.
	All low voltage models are CSA certified to product class 4215-01 and available with CSA B149.1 fuel train.		The generator set package is available certified for seismic application in accordance with International Building Code.

Warning: Back feed to a utility system can cause electrocution and/or property damage. Do not connect to any building's electrical system except through an approved device or after building main switch is open.

For more information contact your local Cummins distributor or visit power.cummins.com

Our energy working for you.™



©2019 Cummins Inc. All rights reserved. Cummins is a registered trademark of Cummins Inc. PowerCommand, Acumen, AmpSentry, InPower and "Our energy working for you." are trademarks of Cummins Inc. Other company, product, or service names may be trademarks or service marks of others. Specifications are subject to change without notice.

NAS-5692 (10/24) A052F982

Generator set data sheet



Model: **C25 N6**
kW rating: **25.0 natural gas Standby**
25.0 propane Standby
Frequency: **60 Hz**
Fuel type: **Natural gas/propane**
Emissions level: **EPA emissions**

Fuel consumption	Natural gas				Propane			
	Standby				Standby			
	kW (kVA)				kW (kVA)			
Ratings	25.0 (31.3)				25.0 (31.3)			
Load	1/4	1/2	3/4	Full	1/4	1/2	3/4	Full
scfh	123.8	185.7	247.6	309.5	51.6	75.6	99.6	125.4
m³/hr	3.51	5.26	7.01	8.77	1.46	2.14	2.82	3.55

Engine	Natural gas		Propane
	Standby rating		Standby rating
Engine model	QSJ2.4G-G4		
Configuration	Cast iron, in-line 4 cylinder		
Aspiration	Naturally aspirated		
Gross engine power output, kW _m (bhp)	30 (40)		32 (43.5)
Bore, mm (in.)	86.5 (3.41)		
Stroke, mm (in.)	100.0 (3.94)		
Rated speed, rpm	1800		
Compression ratio	9.5:1		
Lube oil capacity, L (qt)	4 (4.54)		
Overspeed limit, rpm	2250		

Fuel supply pressure	
Minimum operating pressure, kPa (in H ₂ O)	1.5 (6.0)
Maximum operating pressure, kPa (in H ₂ O)	3.2 (13.0)

Air	Natural gas	Propane
	Standby rating	Standby rating
Combustion air, m ³ /min (scfm)	1.5 (51.8)	1.3 (46.5)
Maximum air cleaner restriction, kPa (in H ₂ O)	1.24 (5.0)	
Alternator cooling air, m ³ /min (scfm)	N/A	

Exhaust

Exhaust flow at rated load, m ³ /min (cfm)	5.3 (188.1)	4.6 (165.3)
Exhaust temperature, °C (°F)	618 (1145)	628 (1162)
Exhaust back pressure (maximum allowable at engine), kPa (in H ₂ O)	5.0 (20)	5.0 (20)
Exhaust back pressure (actual with factory fitted muffler), kPa (in H ₂ O)	1.75 (7)	

Standard set-mounted radiator cooling

Ambient design, °C (°F)	50 (122)
Fan load, kW (HP)	0.74 (1.0)
Coolant capacity (with radiator), L (US gal)	12 (3.1)
Cooling system air flow, m ³ /min (scfm)	60.2 (2150)
Maximum cooling air flow static restriction, kPa (in H ₂ O)	0.12 (0.5)

Weights²

Unit dry weight kgs (lbs)	Refer to drawings for specific weights and dimensions
Unit wet weight kgs (lbs)	

Notes:

¹For non-standard remote installations contact your local Cummins representative.

²Weights represent a set with 1-phase with sound level 1 enclosure.

Alternator data

Standard alternators		Natural gas/ propane single phase table	Natural gas/propane three phase table			
Maximum temperature rise above 40 °C ambient		120 °C	120 °C	120 °C	120 °C	120 °C
Feature code		B949-2	B986-2	B946-2	B943-2	B952-2
Alternator data sheet number		ADS-571	ADS-571	ADS-571	ADS-571	ADS-571
Voltage ranges		120/240	120/240	120/208	277/480	347/600
Voltage feature code		R104-2	R106-2	R098-2	R002-2	R114-2
Surge kW		24.4/26.7	24.8/27.1	24.8/27.1	24.8/27.1	24.8/27.1
Motor starting kVA (at 90% sustained voltage)	Shunt	57	59	59	59	59
	EBS	93	94	94	94	94
Full load current amps at Standby rating		104	75	87	38	30

Optional alternators for improved motor starting capability		Natural gas/ propane single phase table	Natural gas/propane three phase table			
Maximum temperature rise above 40 °C ambient			105 °C	105 °C	105 °C	105 °C
Feature code			BB94-2	BB93-2	BB95-2	BB92-2
Alternator data sheet number			ADS-574	ADS-574	ADS-574	ADS-574
Voltage ranges			120/240	120/208	277/480	347/600
Voltage feature code			R106-2	R098-2	R002-2	R114-2
Surge kW			24.9/27.2	24.9/27.2	24.9/27.2	24.9/27.2
Motor starting kVA (at 90% sustained voltage)	Shunt		71	71	71	71
	EBS		113	113	113	113
Full load current amps at Standby rating			75	87	38	30

Derating factors

Standby	<p>Natural gas: Engine power available up to 0 m (0 ft) at ambient temperatures up to 25 °C (77 °F). Above these elevations derate at 4% per 305 m (1000 ft) and 2% per 10 °C above 25 °C (77 °F).</p> <p>Propane: Engine power available up to 114 m (375 ft) at ambient temperatures up to 25 °C (77 °F). Above these elevations derate at 4% per 305 m (1000 ft) and 2% per 10 °C above 25 °C (77 °F).</p>
----------------	---

Ratings definitions

Emergency Standby Power (ESP):	Limited-Time Running Power (LTP):	Prime Power (PRP):	Base Load (Continuous) Power (COP):
Applicable for supplying power to varying electrical load for the duration of power interruption of a reliable utility source. Emergency Standby Power (ESP) is in accordance with ISO 8528. Fuel stop power in accordance with ISO 3046, AS 2789, DIN 6271 and BS 5514.	Applicable for supplying power to a constant electrical load for limited hours. Limited-Time Running Power (LTP) is in accordance with ISO 8528.	Applicable for supplying power to varying electrical load for unlimited hours. Prime Power (PRP) is in accordance with ISO 8528. Ten percent overload capability is available in accordance with ISO 3046, AS 2789, DIN 6271 and BS 5514.	Applicable for supplying power continuously to a constant electrical load for unlimited hours. Continuous Power (COP) is in accordance with ISO 8528, ISO 3046, AS 2789, DIN 6271 and BS 5514.

Formulas for calculating full load currents:

Three phase output	Single phase output
$\frac{\text{kW} \times 1000}{\text{Voltage} \times 1.73 \times 0.8}$	$\frac{\text{kW} \times \text{SinglePhaseFactor} \times 1000}{\text{Voltage}}$

Warning: Back feed to a utility system can cause electrocution and/or property damage. Do not connect to any building's electrical system except through an approved device or after building main switch is open.

For more information contact your local Cummins distributor or visit power.cummins.com

Our energy working for you.™





PowerCommand®

1.1 Control System



Description

The PowerCommand control system is a microprocessor-based generator set monitoring, metering and control system designed to meet the demands of today's engine driven generator sets. The integration of all control functions into a single control system provides enhanced reliability and performance compared to conventional generator set control systems. These control systems have been designed and tested to meet the harsh environment in which gensets are typically applied.

Features

Easy to view: HMI 211RS for residential use. 128 x 64 pixel graphic LED backlight LCD.

Easy to use: Tactile buttons for generator set start/stop. Residential Standby display for convenient use.

Modbus® interface: Eliminates need for MODLON.

Progressive protective functions: Advanced Overcurrent Protection – Generator set monitoring & protection.

Digital voltage regulation: Single phase full wave SCR type regulator compatible with either shunt or PMSG systems.

Digital engine speed governing: Provides isochronous frequency regulation.

12 and 24 VDC battery operation.

Automatic mains failure: Smooth & automatic transfer and re-transfer of load from utility to generator set & vice-versa.

Exerciser clock: Runs generator set exerciser routines for dependability of operation.

Warranty and service: Backed by a comprehensive warranty and worldwide distributor service network.

Certification: Suitable for use on generator sets that are designed, manufactured, tested and certified to relevant UL, NFPA, ISO, IEC Mil Std., CE, UKCA and CSA standards.

PowerCommand Digital Generator Set Control PCC 1302



Description

The PowerCommand generator set control is suitable for use on a wide range of generator sets in non-parallel applications. The PowerCommand control is compatible with shunt or PMG excitation style. It is suitable for use with reconnectable or non-reconnectable generators, and it can be configured for any frequency, voltage and power connection from 120-600 VAC Line-to-Line.

Power for this control system is derived from the generator set starting batteries. The control functions over a voltage range from 8 VDC to 30 VDC.

Features

- 12 and 24 VDC battery operation.
- Digital voltage regulation.
- Digital engine speed governing (where applicable) - Provides isochronous frequency regulation.
- Full authority engine communications (where applicable) - Provides communication and control with the Engine Control Module (ECM).
- Common harnessing - with higher feature Cummins controls allows for easy field upgrades.
- Generator set monitoring - Monitors status of all critical engine and alternator functions.
- Digital genset metering (AC and DC).
- Genset battery monitoring system - to sense and warn against a weak battery condition.
- Engine starting - Includes relay drivers for starter, fuel shut off (FSO), glow plug/spark ignition power and switch B+ applications.
- Generator set protection - Protects engine and alternator.
- Advanced serviceability - using InPower™, a PC-based software service tool.
- Environmental protection - The control system is designed for reliable operation in harsh environments. The main control board is a fully encapsulated module that is protected from the elements.
- Exerciser function – Routine exercising of generator set.
- Supports dual fuel control.
- Automatic Mains Failure function built in generator set controller. Modbus interface - for interconnecting to customer equipment.

- Configurable inputs and outputs - Four discrete inputs and two dry contact relay outputs.
- Warranty and service - Backed by a comprehensive warranty and worldwide distributor service network.
- Certifications - Suitable for use on generator sets that are designed, manufactured, tested and certified to relevant UL, NFPA, ISO, IEC, Mil Std., CE, UKCA and CSA standards.

Base Control Functions

HMI capability

Operator adjustments - The HMI includes provisions for many set up and adjustment functions.

Generator set hardware data - Access to the control and software part number, generator set rating in kVA and generator set model number is provided from the HMI or InPower™.

Data logs - Includes engine run time, controller on time, number of start attempts.

Fault history - Provides a record of the most recent fault conditions with control hours time stamp. Up to 10 events are stored in the control non-volatile memory.

Alternator data

- Voltage (single or three phase Line-to-Line and Line-to-Neutral)
- Current (single or three phase)
- kVA (three phase and total)
- Frequency
- Engine data
- Starting battery voltage
- Engine speed
- Engine temperature
- Engine oil pressure
- Partial Full Authority Engine (FAE) data (where applicable)
- Service adjustments - The HMI includes provisions for adjustment and calibration of generator set control functions. Adjustments are protected by a password. Functions include:
 - Engine speed governor adjustments
 - Voltage regulation adjustments
 - Cycle cranking
 - Configurable fault set up
 - Configurable output set up
 - Meter calibration
 - Units of measurement

Engine control

SAE-J1939 CAN interface to full authority ECMs (where applicable) - Provides data swapping between genset and engine controller for control, metering and diagnostics.

12 VDC/24 VDC battery operations - PowerCommand will operate either on 12 VDC or 24 VDC batteries.

Isochronous governing (where applicable) - Capable of controlling engine speed within +/-0.25% for any steady state load from no load to full load. Frequency drift will not exceed +/-0.5% for a 33 °C (60 °F) change in ambient temperature over an 8 hour period.

Temperature dependent governing dynamics (with electronic governing) - Modifies the engine governing control parameters as a function of engine temperature. This allows the engine to be more responsive when warm and more stable when operating at lower temperature levels.

Remote start mode - Accepts a ground signal from remote devices to automatically start the generator set and immediately accelerate to rated speed and voltage. The remote start signal will also wake up the control from sleep mode. The control can incorporate a time delay start and stop.

Remote and local Emergency stop - The control accepts a ground signal from a local (genset mounted) or remote (facility mounted) Emergency stop switch to cause the generator set to immediately shut down. The generator set is prevented from running or cranking with the switch engaged. If in sleep mode, activation of either Emergency stop switch will wake up the control.

Sleep mode - The control includes a configurable low current draw state to minimize starting battery current draw when the genset is not operating. The control can also be configured to go into a low current state while in auto for Prime applications or applications without a battery charger.

Engine starting - The control system supports automatic engine starting. Primary and backup start disconnects are achieved by one of three methods: magnetic pickup, battery charging alternator feedback or main alternator output frequency. The control also supports configurable glow plug control when applicable.

Cycle cranking - Configurable for the number of starting cycles (1 to 7) and duration of crank and rest periods. Control includes starter protection algorithms to prevent the operator from specifying a starting sequence that might be damaging.

Time delay start and stop (cooldown) - Configurable for time delay of 0-300 seconds prior to starting after receiving a remote start signal and for time delay of 0-600 seconds prior to shut down after signal to stop in normal operation modes. Default for both time delay periods is 0 seconds.

Alternator control

The control includes an integrated line-to-line sensing voltage regulation system that is compatible with shunt or PMG excitation systems. The voltage regulation system is full wave rectified and has an SCR output for good motor starting capability. Major system features include:

Digital output voltage regulation - Capable of regulating output voltage to within +/-1.0% for any loads between no load and full load. Voltage drift will not exceed +/-1.5% for a 40 °C (104 °F) change in temperature in an eight hour period. On engine starting or sudden load acceptance, voltage is controlled to a maximum of 5% overshoot over nominal level.

The automatic voltage regulator feature can be disabled to allow the use of an external voltage regulator.

Torque-matched V/Hz overload control - The voltage roll-off set point and rate of decay (i.e. the slope of the V/Hz curve) is adjustable in the control.

Protective Functions

On operation of a protective function the control will indicate a fault by illuminating the appropriate status LED on the HMI, as well as display the fault code and fault description on the LCD. The nature of the fault and time of occurrence are logged in the control. The service manual and InPower service tool provide service keys and procedures based on the service codes provided. Protective functions include:

Battle short mode

When enabled and the battle short switch is active, the control will allow some shutdown faults to be bypassed. If a bypassed shutdown fault occurs, the fault code and description will still be annunciated, but the genset will not shutdown. This will be followed by a fail to shutdown fault. Emergency stop shutdowns and others that are critical for proper operation are not bypassed. Please refer to the Control Application Guide or Manual for list of these faults.

Configurable alarm and status inputs

The control accepts up to four alarm or status inputs (configurable contact closed to ground or open) to indicate a configurable (customer-specified) condition. The control is programmable for warning, shutdown or status indication and for labelling the input.

Emergency stop

Annunciated whenever either Emergency stop signal is received from external switch.

General engine protection

Low and high battery voltage warning - Indicates status of battery charging system (failure) by continuously monitoring battery voltage.

Weak battery warning - The control system will test the battery each time the generator set is signaled to start and indicate a warning if the battery indicates impending failure.

Fail to start (overcrank) shutdown - The control system will indicate a fault if the generator set fails to start by the completion of the engine crank sequence.

Fail to crank shutdown - Control has signaled starter to crank engine but engine does not rotate.

Cranking lockout - The control will not allow the starter to attempt to engage or to crank the engine when the engine is rotating.

Hydro mechanical fuel system engine protection

Overspeed shutdown - Default setting is 115% of nominal.

Low lube oil pressure warning/shutdown - Level is pre-set (configurable with InPower) to match the capabilities of the engine used. Control includes time delays to prevent nuisance alarms.

High lube oil temperature warning/shutdown - Level is pre-set (configurable with InPower) to match the capabilities of the engine used. Control includes time delays to prevent nuisance alarms.

High engine temperature warning/shutdown - Level is pre-set (configurable with InPower) to match the capabilities of the engine used. Control includes time delays to prevent nuisance alarms.

Low coolant temperature warning - Indicates that engine temperature may not be high enough for a 10 second start or proper load acceptance.

Sensor failure indication - Logic is provided on the base control to detect analog sensor or interconnecting wiring failures.

Full authority electronic engine protection

Engine fault detection is handled inside the engine ECM. Fault information is communicated via the SAE-J1939 data link for annunciation in the HMI

Alternator protection

High AC voltage shutdown (59) - Output voltage on any phase exceeds pre-set values. Time to trip is inversely proportional to amount above threshold. Values adjustable from 105-130% of nominal voltage, with time delay adjustable from 0.1-10 seconds. Default value is 110% for 10 seconds.

Low AC voltage shutdown (27) - Voltage on any phase has dropped below a pre-set value. Adjustable over a range of 50-95% of reference voltage, time delay 2-20 seconds. Default value is 85% for 10 seconds.

Overcurrent warning/shutdown - Implementation of the thermal damage curve with instantaneous trip level calculated based on current transformer ratio and application power rating.

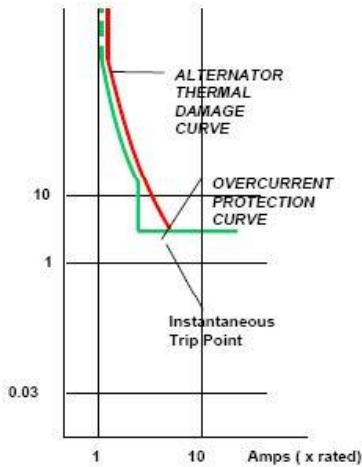

Under frequency shutdown (81 u) - Generator set output frequency cannot be maintained. Settings are adjustable from 2-10 Hz below nominal governor set point, for a 5-20 second time delay. Default: 6 Hz, 10 seconds.

Over frequency shutdown/warning (81 o) - Generator set is operating at a potentially damaging frequency level. Settings are adjustable from 2-10 Hz above nominal governor set point for a 1-20 second time delay. Default: 6 Hz, 10 seconds, enabled.

Loss of sensing voltage shutdown - Shutdown of generator set will occur on loss of voltage sensing inputs to the control.

Field overload shutdown - Uses field voltage to shutdown generator set when a field overload condition occurs.

Advanced Functions

Automatic mains failure*

The built in AMF feature provides the automatic transfer and re-transfer of the load from utility to generator set and vice-versa.

- Automatically starts-stops the generator set in the event of utility failure.
- Annunciates faults.

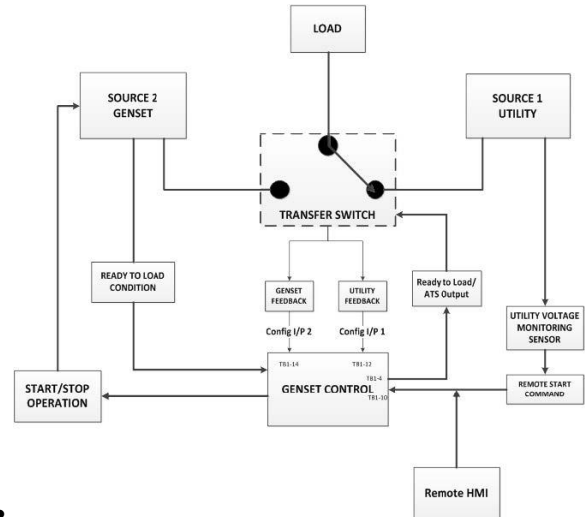

- * A utility voltage monitoring sensor (as shown in the AMF diagram above) must be connected in order to use the AMF feature on the 1302 control. Use Schneider Electric Relay RSB1A120U7 and Socket RSZE1S35M.

Exerciser clock

The exerciser clock runs the generator set exerciser routines for dependability of operation.

Field Control Interface

Input signals to the base control include:

- Remote start
- Local and Emergency stop
- Configurable inputs: Control includes (4) input signals from customer discrete devices that are configurable for warning, shutdown or status indication, as well as message displayed.

Output signals from the PowerCommand control include:

- Configurable relay outputs: Control includes (2) relay output contacts rated at 2 A. These outputs can be configured to activate on any control warning or shutdown fault as well as ready to load, not in auto, common alarm, common warning and common shutdown.
- Ready to load (generator set running) signal: Operates when the generator set has reached 90% of rated speed and voltage and latches until generator set is switched to off or idle mode.

PowerCommand Human Machine Interface HMI211



Description

This control system includes an intuitive operator interface panel that allows for complete genset control as well as system metering, fault annunciation, configuration and diagnostics. The interface includes five generator set status LED lamps with both internationally accepted symbols and English text to comply with customer needs. The interface also includes an LED backlit LCD display with tactile feel soft-switches for easy operation and screen navigation. It is configurable for units of measurement and has adjustable screen contrast and brightness.

The *run/off/auto* switch function is integrated into the interface panel.

All data on the control can be viewed by scrolling through screens with the navigation keys. The control displays the current active fault and a time-ordered history of the five previous faults.

Features

- LED indicating lamps:
 - Remote start
 - Not in auto
 - Shutdown
 - Warning
 - Auto
 - Run
- 128 x 64 pixels graphic LED backlight LCD.
- Four tactile feel membrane switches for LCD defined operation. The functions of these switches are defined dynamically on the LCD.
- Two tactile feel membrane switches dedicated for off and back.
- Allows for complete genset control setup.
- Certifications: Suitable for use on generator sets that are designed, manufactured, tested and certified to relevant UL, NFPA, ISO, IEC, Mil Std., CE, UKCA and CSA standards.
- HMI 211RS provides convenience for residential use.

Communications Connections

PC tool interface - This RS-485 communication port allows the HMI to communicate with a personal computer running InPower.

This RS-485 communication port allows the HMI to communicate with the main control board.

Mechanical Drawing

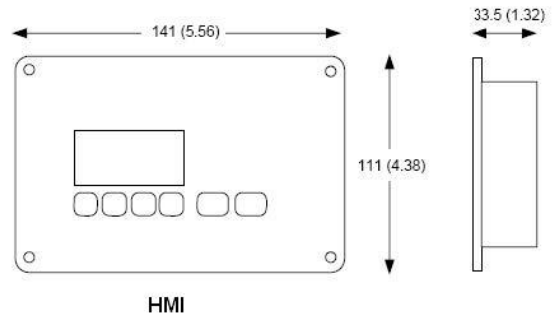

Dimensions: mm (inches)

Software

InPower (beyond 6.0 version) is a PC-based software service tool that is designed to directly communicate to PowerCommand generator sets and transfer switches, to facilitate service and monitoring of these products.

Environment

The control is designed for proper operation without recalibration in ambient temperatures from -40 °C (-40 °F) to +70 °C (158 °F), and for storage from -55 °C (-67 °F) to +80 °C (176 °F). Control will operate with humidity up to 95%, non-condensing.

The HMI is designed for proper operation in ambient temperatures from -40 °C* (-40 °F) to +70 °C (158 °F), and for storage from -40 °C* (-40 °F) to +80 °C (176 °F).

The control board is fully encapsulated to provide superior resistance to dust and moisture. Display panel has a single membrane surface, which is impervious to effects of dust, moisture, oil and exhaust fumes. This panel uses a sealed membrane to provide long reliable service life in harsh environments.

The control system is specifically designed and tested for resistance to RFI/EMI and to resist effects of vibration to provide a long reliable life when mounted on a generator set. The control includes transient voltage surge suppression to provide compliance to referenced standards.

* Heater accessory (pn: A040H853) is available for enhanced operation below -20 °C

Certifications

PowerCommand meets or exceeds the requirements of the following codes and standards:

- NFPA 110 for level 1 and 2 systems.
- ISO 8528-4: 1993 compliance, controls and switchgear.
- CE and UKCA marking: The control system is suitable for use on generator sets to be CE and UKCA-marked.
- EN 50081-1,2 residential/light industrial emissions or industrial emissions.
- EN 50082-1,2 residential/light industrial or industrial susceptibility.
- ISO 7637-2, level 2: DC supply surge voltage test.
- Mil Std. 202C, Method 101 and ASTM B117: Salt fog test.
- PowerCommand control systems and generator sets are designed and manufactured in ISO 9001 certified facilities.
- UL 6200 recognized and suitable for use on UL 2200 Listed generator sets.
- CSA C282-M1999 compliance.
- CSA 22.2 No. 14 M91 industrial controls.

Warranty

All components and subsystems are covered by an express limited one year warranty. Other optional and extended factory warranties and local distributor maintenance agreements are available

Accessories

1301-1302 Upgrade Kit (HM)	0541-1431
PowerCommand 500 (LAN)	A040X126
Remote HMI 211	0541-1394
Remote HMI 211RS	A046K103
I/O Expansion (Aux 101)	0541-1291
HMI Heater Accessory Kit	A040H853

Parts Ordering Information

1302 Control Board	0327-1617-02
1302 control Board – Arrow	A043W505
Aux 104 (Governor Control)	0327-1507
HMI 211 Without Heater	0300-6014
HMI 211 with Heater	A026G237

Additional Resources

Resource	Where to find
1302 Service Manual	QSOL
Accessories Catalog	cumminspower.com
Additional Controls Information	PowerSuite Library



For more information contact your local Cummins distributor or visit power.cummins.com

Our energy working for you.™





Alternator data sheet

Frame size: CA115-L14

Characteristics					
No of bearings:	1				
Weights:	Stator assembly:	209.3 lb	94.9 kg		
	Rotor assembly:	99.9 lb	45.3 kg		
	Complete assembly:	309 lb	140 kg		
Maximum speed:	2250 rpm				
Insulation system:	Class H throughout				
	60 Hz Voltage (winding no)				
	<u>208</u> (311)	<u>480</u> (41)	<u>240</u> (17)	<u>240</u> (06)	<u>240</u> (311)
Excitation current: Full load	1.93	1.98	2.01	1.53	1.93
Excitation current: No load	0.53	0.56	0.57	0.53	0.53
3 Ø Ratings (0.8 power factor)	<u>208</u> (311)	<u>480</u> (41)	<u>600</u> (17)	<u>240</u> (06)	<u>240</u> (311)
(Based on specific temperature rise at 40° C ambient temperature)					
120° C Rise peak Standby ratings	kW	25	25	25	25
	kVA	31.25	31.25	31.25	31.25
105° C Rise peak Standby ratings	kW	22.9	22.9	22.9	22.9
	kVA	28.6	28.6	28.6	28.6
1 Ø Ratings (1.0 power factor)				<u>240</u> (06)	
(Based on specific temperature rise at 40° C ambient temperature)					
120° C Rise peak Standby ratings	kW			25	
	kVA			25	
105° C Rise peak Standby ratings	kW			22.9	
	kVA			22.9	
Reactances (per unit ± 30%)	<u>208</u> (311)	<u>480</u> (41)	<u>600</u> (17)	<u>240</u> (06)	<u>240</u> (311)
(Based on full load at 105° C rise rating)					
Synchronous	1.75	1.79	1.75	1.40	1.75
Transient	0.11	0.11	0.11	0.14	0.11
Subtransient	0.08	0.08	0.08	0.09	0.08
Negative sequence	0.15	0.15	0.15	0.19	0.15
Zero sequence	0.07	0.07	0.08	0.08	0.07
Motor starting	<u>208</u> (311)	<u>480</u> (41)	<u>600</u> (17)	<u>240</u> (06)	<u>240</u> (311)
Maximum kVA (90% sustained voltage)					
(At 20° C nominal generator & ambient temperature)	(EBS)	94	94	78	94
	(Shunt)	59	59	48	59



Alternator data sheet

Frame size: CA115-L14

	<u>208</u> (311)	<u>480</u> (41)	<u>600</u> (17)	<u>240</u> (06)	<u>240</u> (311)
Time constants (sec)					
Transient	0.024	0.024	0.024	0.026	0.024
Subtransient	0.006	0.006	0.006	0.006	0.006
Open circuit	0.54	0.54	0.54	0.44	0.54
DC	0.005	0.005	0.005	0.006	0.005
Windings (@ 20° C)	<u>208</u> (311)	<u>480</u> (41)	<u>600</u> (17)	<u>240</u> (06)	<u>240</u> (311)
Stator resistance (Ohms per phase)	0.398	0.552	0.874	0.092	0.398
Rotor resistance (Ohms)	0.668	0.668	0.668	0.668	0.668
Number of leads	12	12	12	4	12



Sound pressure level @ 7 meters, dB(A)

See notes 1-6 listed below

Configuration		Position (note 1)								8 position average
		1	2	3	4	5	6	7	8	
F217-2 – sound attenuated level 2	Mounted	67.0	68.4	67.8	67.8	67.1	67.2	67.2	66.5	67.4
F231-2 – sound attenuated level 1	Mounted	71.1	68.5	67.9	68.2	67.4	67.8	67.6	69.3	68.64
Standard – unhoused	Infinite exhaust	72.7	71.7	72.1	72.1	72.6	72.4	72.3	72.0	72.3

Sound power level, dB(A)

See notes 2-4, 7, 8 listed below

Configuration		Octave band center frequency (Hz)									Overall sound power level
		31.5	63	125	250	500	1000	2000	4000	8000	
F217-2 – sound attenuated level 2	Mounted	45.4	86.7	79	91	86.5	83.9	77.9	76.9	68.8	94.3
F231-2 – sound attenuated level 1	Mounted	44.4	87.2	79.7	91.6	87.8	85.9	80.7	78.9	77.5	95.2

Exhaust sound power level, dB(A)

See notes 2, 9 listed below

Open exhaust (no muffler) @ rated load	Octave band center frequency (Hz)									Overall sound power level
	31.5	63	125	250	500	1000	2000	4000	8000	
	40.7	89.3	108.4	109.5	107.2	110.8	108.4	107.2	102.4	116.8

Note:

1. Position 1 faces the generator front per ISO 8528-10. The positions proceed around the generator set in a counter-clockwise direction in 45° increments. All position are at 7 m (23 ft) from surface of the generator set and 1.2 m (48 in.) from floor level.
2. Sound levels are subject to instrumentation, measurement, installation and manufacturing variability.
3. Data based on full rated load.
4. Sound data with generator sets with infinite exhaust do not include exhaust noise.
5. Sound pressure levels are measured per ANSI S1.13 and ANSI S12.18, as applicable.
6. Reference sound pressure is 20 µPa.
7. Sound power levels per ISO 3744 and ISO 8528-10, as applicable.
8. Reference power = 1 pw (10⁻¹²W).
9. Exhaust sound power levels are per ISO 6798, as applicable.



High ambient air temperature radiator cooling system

	Fuel type	Duty	Rating (Kw)	Max cooling @ air flow static restriction, unhooused (inches water/mm water)					Housed in free air, no air discharge restriction	
				0.0/0.0	0.25/6.4	0.5/12.7	0.75/19.1	1.0/25.4	F231	F217
				Maximum allowable ambient temperature, degree C						
60 Hz	Natural Gas	Standby	25	55	55	55	N/A	N/A	55	55

High ambient air temperature radiator cooling system

	Fuel type	Duty	Rating (Kw)	Max cooling @ air flow static restriction, unhooused (inches water/mm water)					Housed in free air, no air discharge restriction	
				0.0/0.0	0.25/6.4	0.5/12.7	0.75/19.1	1.0/25.4	F231	F217
				Maximum allowable ambient temperature, degree C						
60 Hz	Propane	Standby	25	55	55	55	N/A	N/A	55	55

Notes:

1. Data shown are anticipated cooling performance for typical generator set.
2. Cooling data is based on 1000 ft (305 m) site test location.
3. Generator set power output may need to be reduced at high ambient conditions. Refer generator set data sheet for derate schedules.
4. Cooling performance may be reduced due to several factors including but not limited to: Incorrect installation, improper operation, fouling of the cooling system, and other site installation variables.



Exhaust emission data sheet

C25 N6

60 Hz Spark ignited generator set EPA emissions

Engine information:

Model:	QSJ2.4	Bore:	3.41 in. (86.5 mm)
Type:	4 cycle, in-line, 4 cylinder	Stroke:	3.94 in. (100 mm)
Aspiration:	Naturally aspirated	Displacement:	146.46 cu. in. (2.4 liters)
Compression ratio:	9.5:1		
Emission control device:	Electronic air/fuel ratio control, and closed-loop breather system.		

<u>Performance data</u>	<u>Natural gas</u>	<u>Propane</u>
	<u>Standby</u>	<u>Standby</u>
BHP @ 1800 RPM (60 Hz)	40	43.5
Fuel consumption (SCFH)	309.5	125.4
Air to fuel ratio	16.5	14.7
Exhaust gas flow (CFM)	188.1	165.3
Exhaust gas temperature (°F)	1265	1300
<u>Exhaust emission data</u>		
HC (Total unburned hydrocarbons)*	114	597
NOx (Oxides of nitrogen as NO2)	1817	1837
CO (Carbon monoxide)	11010	16573
		Values are ppmvd
HC (Total unburned hydrocarbons)*	0.18	0.84
NOx (Oxides of nitrogen as NO2)	7.13	6.72
CO (Carbon monoxide)	30.46	42.66

Values are Grams per HP-Hour

*HC includes all NMHC, VOC, POC, and ROC constituents (Non-Methane HC, Volatile Organic Compounds, Precursor Organic Compounds, and Reactive Organic Compounds).

Test conditions

Data was recorded during steady-state rated engine speed (± 25 RPM) with full load ($\pm 2\%$). Pressures, temperatures, and emission rates were stabilized.

Fuel specification:

Natural gas	Dry gas as received from Supplier (1000 BTU/SCF).
Propane	Meets the requirements for Commercial Grade Propane under the ASTM D1835 Standard Specification for Liquefied Gases
Fuel temperature	60 \pm 9 °F at Flow Transmitter
Fuel pressure	14.73 PSIA \pm 0.5 PSIA at Flow Transmitter
Intake air temperature:	77 \pm 9 °F at inlet
Barometric pressure:	29.92 in. Hg \pm 1 in. Hg
Humidity:	NOx measurement corrected to 75 grains H2O/lb dry air

The NOx, HC, and CO emission data tabulated here were from a single engine under the test conditions shown above. These data are subjected to instrumentation and engine-to-engine variability. Field emission test data are not guaranteed to these levels. Actual field test results may vary due to test site conditions, installation, fuel specification, test procedures and instrumentation. Engine operation with excessive air intake or exhaust restriction beyond published maximum limit, or with improper maintenance, may result in elevated emission levels.



Prototype Test Support (PTS) 60 Hz test summary



Generator set models

C20 N6	C30 N6H
C22 N6	C36 N6H
C25 N6	C40 N6H
C30 N6	C45 N6H
C36 N6	C50 N6H
C40 N6	C60 N6H

Representative prototype

Model:	C40 N6H
Alternator:	CA115-T12
Engine:	QSJ2.4

The following summarizes prototype testing conducted on the designated representative prototype of the specified models. This testing is conducted to verify the complete generator set electrical and mechanical design integrity. Prototype testing is conducted only on generator sets not sold as new equipment.

Maximum surge power: 52.3 kW

The generator set was evaluated to determine the stated maximum surge power.

Maximum motor starting: 76 kVA

The generator set was tested to simulate motor starting by applying the specified kVA load at low lagging power factor (0.4 or lower). With this load applied, the generator set recovered to a minimum of 90% rated voltage.

Alternator temperature rise:

The highest rated temperature rise (120 °C) test results are reported as follows to verify that worst case temperature rises do not exceed allowable NEMA MG1 limits for class H insulation. Tests were conducted per IEEE 115, rise by resistance and embedded detector, with the rated voltages. Only the highest temperatures are reported.

<u>Location</u>	<u>Maximum rise (°C)</u>
Alternator stator	103
Alternator rotor	101
Exciter stator	53
Exciter rotor	65

Torsional analysis and testing:

The generator set was tested to verify that the design is not subjected to harmful torsional stresses. A spectrum analysis of the transducer output was conducted over the speed range of 1650 to 1950 RPM.

Cooling system: 50 °C ambient
0.5 in. H₂O restriction

The cooling system was tested to determine ambient temperature and static restriction capabilities. The test was performed at full rated load in elevated ambient temperature under static restriction conditions.

Durability:

The generator set was subjected to a minimum 1000 hour endurance test operating at variable load up to the Standby rating based upon MIL-STD-705 to verify structural soundness and durability of the design.

Electrical and mechanical strength:

The generator set was tested to several single phase and three phase faults to verify that the generator can safely withstand the forces associated with short circuit conditions. The generator set was capable of producing full rated output at the conclusion of the testing.

Steady state performance:

The generator set was tested to verify steady state operating performance was within the specified maximum limits.

Voltage regulation:	± 1%
Random voltage variation:	± 1%
Frequency regulation:	± 0.25%
Random frequency variation:	± 0.25%

Transient performance:

The generator set was tested to verify single step loading capability as required by NFPA 110 and verify acceptable voltage and frequency response on load addition or rejection. The following results were recorded at 0.8 power factor :

Full load acceptance:

Voltage dip:	14.4%
Recovery time:	2.6 seconds
Frequency dip:	4.6%
Recovery time:	2.7 seconds

Full load rejection:

Voltage rise:	11.5%
Recovery time:	3.4 seconds
Frequency rise:	5.6%
Recovery time:	3.4 seconds

Harmonic analysis:

(per MIL-STD-705B, method 601.4)

<u>Harmonic</u>	<u>Line to Line</u>		<u>Line to Neutral</u>	
	<u>No load</u>	<u>Full load</u>	<u>No load</u>	<u>Full load</u>
3	0.3	3.5	0.3	3.2
5	1.1	1.0	0.9	0.9
7	0.7	0.4	0.7	0.3
9	0.0	0.5	0.0	0.4
11	0.2	0.1	0.1	0.1
13	0.1	0.1	0.0	0.0
15	0.0	0.1	0.0	0.1

CERTIFICATE OF COMPLIANCE

SEISMIC DESIGN OF NONSTRUCTURAL COMPONENTS AND SYSTEMS



Certification No.

VMA-51070-01C (Revision 12)

Expiration Date: 4/30/2026

Certification Parameters:

The nonstructural products (mechanical and/or electrical components) listed on this certificate are CERTIFIED¹ FOR SEISMIC APPLICATIONS in accordance with the following building code² releases.

IBC 2018, 2015, 2012

The following model designations, options, and accessories are included in this certification. Reference report number VMA-51070-01 as issued by VMC Group for a complete list of certified models, included accessories/options, and certified installation methods.

Cummins Power Generation, Inc.; Gas Generators
C20-200N6 Series; 20kW - 200kW

The above referenced equipment is APPROVED for seismic application when properly installed³, used as intended, and contains a Seismic Certification Label referencing this Certificate of Compliance⁴. As limited by the tabulated values, below grade, grade, and roof-level installations, installations in essential facilities, for life safety applications, and/or of equipment containing hazardous contents are permitted and included in this certification with an Equipment Importance Factor assigned as $I_p=1.5$. The equipment is qualified by successful seismic shake table testing at the nationally recognized Dynamic Certification Laboratories under the review of the ISO Accredited Product Certification Agency, the VMC Group.

Certified Seismic Design Levels			
Certified IBC	Importance $I_p \leq 1.5$ Soil Classes A-E Risk Categories I-IV Design Categories A-F	z/h ≤ 1.0	z/h = 0.0
		$S_{DS} \leq 2.500 \text{ g}$	$S_{DS} \leq 2.500 \text{ g}$

Certified Seismic Installation Methods
Rigid Mounting From Unit Base To Rigid Structure

CERTIFICATE OF COMPLIANCE

SEISMIC DESIGN OF NONSTRUCTURAL COMPONENTS AND SYSTEMS

Certified Product Table:

Model	Max Rating [kW]	Max Depth [in]	Max Width [in]	Max Height [in]	Max Weight [lb]
C20N6	20	82	34	46	1,110
C22N6	22				1,150
C25N6	25				
C30N6, C30N6H	30	104	40	58	1,300
C36N6, C36N6H	36				1,380
C40N6, C40N6H	40				1,420
C45N6, C45N6H	45				2,580
C50N6, C50N6H	50				2,600
C60N6, C60N6H	60				2,900
C70N6	70	136	40	72	2,870
C80N6	80				3,030
C100N6	100				3,170
C125N6	125	160	40	83	3,770
C150N6	150				4,350
C175N6B, C200N6B	200				4,663
C200N6		4,140			

Note: "H" indicates high speed (3600RPM, as opposed to the standard 1800RPM)

Note: Dimensions and Weight include sound level 2 (SL2) enclosure baffle

Group	Type	S _{DS} (z/h=0)	S _{DS} (z/h=1)	A _{Flex-H}	A _{Rig-H}	A _{Flex-V}	A _{Rig-V}	F _p /W _p
Seismic	AC156	2.500	2.500	4.000	3.000	1.667	0.667	1.875

This certification includes the open generator set and the enclosed generator set. The generator set and included options shall be a catalogue design and factory supplied. The generator set and applicable options shall be installed as attached to the building structure per the manufacturer supplied seismic installation instructions. This certification excludes all non-factory supplied accessories, including but not limited to mufflers, isolation/restraint devices, remote control panels, remote radiators, pumps and other electrical/mechanical components.



VMA-51070-01C (Revision 12)
 Issue Date: July 3, 2015
 Revision Date: March 4, 2025
 Expiration Date: April 30, 2026

CERTIFICATE OF COMPLIANCE

SEISMIC DESIGN OF NONSTRUCTURAL COMPONENTS AND SYSTEMS

Notes & Comments:

1. All equipment listed herein successfully passed the seismic acceptance criteria for shake testing non-structural components and systems as set forth in the ICC AC-156. The Test Response Spectrum (TRS) enveloped the Required Response Spectrum (RRS) for all units tested. The tested units were representative sample(s) of a contingent of models and all remained captive and structurally sound after the seismic shake simulation. The units also remained functionally operational after the simulation testing as functional testing was completed by the equipment manufacturer before and after the seismic simulations. Although a seismic qualified unit inherently contains some wind resisting capacity, that capacity is undetermined and is excluded from this certification. Snow/Ice loads have been neglected and thus limit the unit to be installed both indoors (covered by an independent protective structure) and out of doors (exposed to accumulating snow/ice) for ground snow loads no greater than 30 psf for all applications.
2. The following building codes are addressed under this certification:
 - IBC 2018 referencing ASCE7-16 and ICC-ES AC-156
 - IBC 2015 referencing ASCE7-10 and ICC-ES AC-156
 - IBC 2012 referencing ASCE7-10 and ICC-ES AC-156
3. Refer to the manufacturer supplied installation drawings for anchor requirements and mounting considerations for seismic applications. Required anchor locations, size, style, and load capacities (tension and shear) may be specified on the installation drawings or specified by a 3rd party. Mounting requirement details such as anchor brand, type, embedment depth, edge spacing, anchor-to-anchor spacing, concrete strength, special inspection, wall design, and attachment to non-building structures must be outlined and approved by the Engineer of Record for the project or building. Structural walls, structural floors, and housekeeping pads must also be seismically designed and approved by the project or building Structural Engineer of Record to withstand the seismic anchor loads as defined on the installation drawings. The installing contractor is responsible for ensuring the proper installation of all anchors and mounting hardware.
4. For this certificate and certification to remain valid, this certificate must correspond to the "Seismic Certification Label" found affixed to the unit by the factory. The label ensures the manufacturer built the unit in conformance to the IBC seismic design criteria set forth by the Certified Seismic Qualification Agency, the VMC Group, and meets the seismic design levels claimed by this certificate.
5. Mechanical, Electrical, and Plumbing connections to the equipment must be flexibly attached as to not transfer load through the connection. The structural integrity of any conduit, cable trays, piping, ductwork and/or flexible connections is the responsibility of others. This certification makes no statements of compliance in regards to NEMA, IP, UL, CSA, or other relevant standards after a seismic event. For compliance to other relevant standards, please contact the manufacturer.
6. This certificate applies to units manufactured at:
 - Cummins Power Generation Inc., 1400 73rd Ave. NE, Minneapolis, MN 55432
7. This certification follows the VMC Group's ISO-17065 Scheme.



John P. Giuliano, PE
President, VMC Group

SECTION 3

Generator Accessories



Product data sheet

Specifications

SQUARE D

Green Premium™



Circuit breaker, PowerPacT H, 125A, 2 pole, 600VAC, 14kA, lugs, thermal magnetic,

HDL26125

Main

Range	PowerPact
Product name	PowerPact H
Product or Component Type	Circuit breaker
Device Application	Distribution

Complementary

Line Rated Current	125 A
Number of Poles	2P
Protected poles description	2t
Control Type	Toggle
Breaking capacity code	D
Breaking capacity	25 kA 240 V AC 50/60 Hz UL 489 18 kA 480 V AC 50/60 Hz 14 kA 600 V AC 50/60 Hz 20 kA 250 V DC
[Ue] rated operational voltage	690 V AC 50/60 Hz IEC 60947-3
Network Frequency	50/60 Hz
[Ics] rated service breaking capacity	25 kA 220/240 V AC 50/60 Hz IEC 60947-2 18 kA 380/440/415 V AC 50/60 Hz IEC 60947-2 14 kA 500/525 V AC 50/60 Hz IEC 60947-2 20 kA 250 V DC IEC 60947-2 20 kA 500 V DC IEC 60947-2
[Uimp] rated impulse withstand voltage	8 kV IEC 60947-2
Trip unit technology	Thermal-magnetic
Magnetic tripping current	1700 A
Magnetic hold current	900 A
[Ui] rated insulation voltage	750 V IEC 60947-2
Suitability for isolation	Yes IEC 60947-2
Utilisation category	Category A
AWG gauge	Please see CB outline drawing for lug and termination details

Local signalling	Switched off (OFF) 1 trip indicator green)
Mounting mode	Unit mount lug)
Mounting Support	Lug
Electrical connection	Lugs line Lugs load
Terminal identifier	Please see CB outline drawing for lug and termination details
Tightening torque	44.25 lbf.in (5 N.m) 0.00...0.01 in ² (2.5...6 mm ²) (AWG 14...AWG 10) 123.91 lbf.in (14 N.m) 0.02...0.15 in ² (10...95 mm ²) (AWG 8...AWG 3/0)
Number of slots	2 auxiliary switch OF plug-in) 1 alarm switch SD plug-in) 1 overcurrent trip switch SDE plug-in) 1 voltage release MN or MX plug-in)
Power wire stripping length	0.63 in (16 mm)
Color	Black
Height	6.42 in (163 mm)
Width	4.09 in (104 mm)
Depth	3.39 in (86 mm)
Net Weight	4.85 lb(US) (2.2 kg)
Quantity per Set	1
Communication interface	Modbus Ethernet
Circuit breaker application	HACR rated

Environment

Quality labels	CE
Standards	UL CSA NEMA NOM-003-SCFI-2000 IEC 60947-2
Product certifications	UL CSA NOM
IP degree of protection	Front cover IP40 IEC 60529
Pollution degree	3 IEC 60947-1
Ambient Air Temperature for Operation	28...158 °F (-2...70 °C)
Ambient Air Temperature for Storage	-58...185 °F (-50...85 °C)
Operating altitude	< 6561.68 ft (2000 m) without derating 5000 m with derating

Ordering and shipping details

Category	01110-HD,JD UNIT MT BREAKER/SWITCH
Discount Schedule	DE2
GTIN	785901461944
Returnability	Yes
Country of origin	MX

Packing Units

Unit Type of Package 1	PCE
Number of Units in Package 1	1

Package 1 Height	5.80 in (14.732 cm)
Package 1 Width	7.40 in (18.796 cm)
Package 1 Length	8.80 in (22.352 cm)
Package 1 Weight	3.03 lb(US) (1.375 kg)

Offer Sustainability

Sustainable offer status	Green Premium product
California proposition 65	WARNING: This product can expose you to chemicals including: DINP, which is known to the State of California to cause cancer, and DIDP, which is known to the State of California to cause birth defects or other reproductive harm. For more information go to www.P65Warnings.ca.gov
REACH Regulation	REACH Declaration
EU RoHS Directive	Compliant EU RoHS Declaration
Mercury free	Yes
China RoHS Regulation	China RoHS declaration Product out of China RoHS scope. Substance declaration for your information.
RoHS exemption information	Yes
Environmental Disclosure	Product Environmental Profile
Circularity Profile	End of Life Information
PVC free	Yes

MULTIPLES OF RATED CURRENT

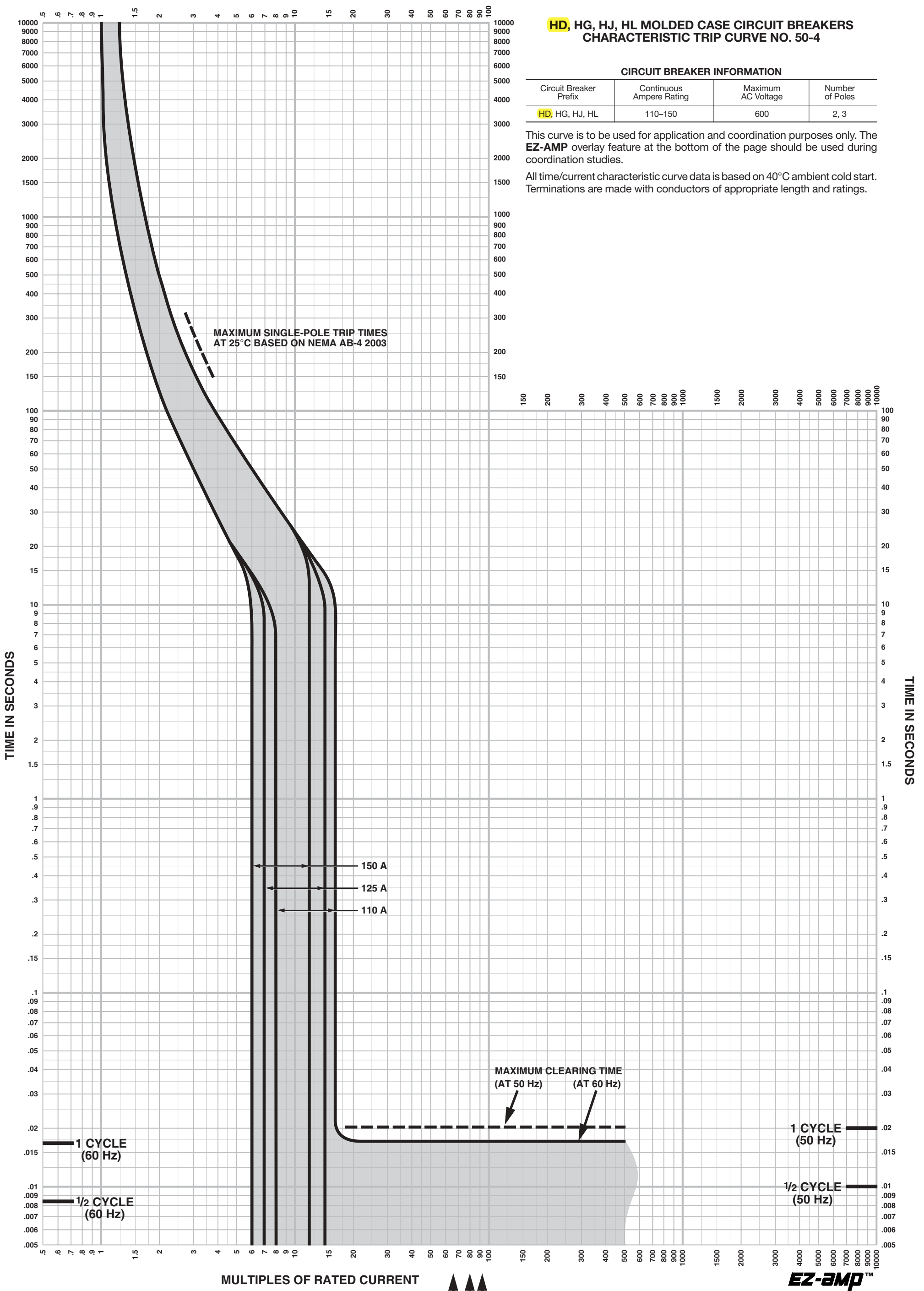

HD, HG, HJ, HL MOLDED CASE CIRCUIT BREAKERS
CHARACTERISTIC TRIP CURVE NO. 50-4

CIRCUIT BREAKER INFORMATION

Circuit Breaker Prefix	Continuous Ampere Rating	Maximum AC Voltage	Number of Poles
HD, HG, HJ, HL	110-150	600	2, 3

This curve is to be used for application and coordination purposes only. The **EZ-AMP** overlay feature at the bottom of the page should be used during coordination studies.

All time/current characteristic curve data is based on 40°C ambient cold start. Terminations are made with conductors of appropriate length and ratings.

Instruction Sheet

A046J596 (Issue 1)

7-2013

Installation Instructions for Enclosure S1 to S2 Upgrade Kits A043J733 and A043U607

1 Introduction

The information contained within is based on information available at the time of going to print. In line with Cummins Power Generation policy of continuous development and improvement, information may change at any time without notice. The users should therefore make sure that before commencing any work, they have the latest information available. The latest version of this manual is available on QuickServe Online (<https://qsol.cummins.com/info/index.html>).

2 Safety Precautions

2.1 General Safety Precautions

⚠ WARNING

Coolants under pressure can cause severe scalding. Do not open a radiator or heat exchanger pressure cap while the engine is running. Let the engine cool down before removing the coolant pressure cap. Turn the cap slowly and do not open it fully until the pressure has been relieved.

⚠ WARNING

Moving parts can cause severe personal injury or death and hot exhaust parts can cause severe burns. Make sure all protective guards are properly in place before starting the generator set.

⚠ WARNING

Used engine oils have been identified by some state and federal agencies to cause cancer or reproductive toxicity. Do not ingest, breathe the fumes, or contact used oil when checking or changing engine oil.

⚠ WARNING

Operation of equipment is unsafe when mentally or physically fatigued. Do not operate equipment in this condition, or after consuming any alcohol or drug.

⚠ WARNING

Substances in exhaust gases have been identified by some state and federal agencies to cause cancer or reproductive toxicity. Do not breath in or come into contact with exhaust gases.

⚠ WARNING

Flammable liquids can cause fire or explosion. Do not store fuel, cleaners, oil, etc. near the generator set.

⚠ WARNING

Wear hearing protection when going near an operating generator set .

⚠ WARNING

Hot metal parts can cause severe burns. Avoid contact with the radiator, turbo charger, and exhaust system.

⚠ WARNING

Maintaining or installing a generator set can cause severe personal injury. Wear personal protective equipment such as safety glasses, protective gloves, hard hats, steel-toed boots, and protective clothing when working on equipment.

⚠ WARNING

Ethylene glycol, used as engine coolant, is toxic to humans and animals. Clean up coolant spills and dispose of used antifreeze in accordance with local environmental regulations.

⚠ WARNING

Starting fluids, such as ether, can cause explosion and generator set engine damage. Do not use.

⚠ CAUTION

Stepping on the generator set can cause parts to bend or break, leading to electrical shorts, or to fuel, coolant, or exhaust leaks. Do not step on the generator set when entering or leaving the generator room.

⚠ CAUTION

To prevent accidental or remote starting while working on the generator set, disconnect the negative (-) battery cable at the battery using an insulated wrench.

⚠ CAUTION

Make sure that rags are not left on or near the engine.

⚠ CAUTION

Make sure the generator set is mounted in a manner to prevent combustible materials from accumulating under the unit.

⚠ CAUTION

Accumulated grease and oil can cause overheating and engine damage presenting a potential fire hazard. Keep the generator set clean and repair any oil leaks promptly.

⚠ CAUTION

Before performing maintenance and service procedures on enclosed generator sets, make sure the service access doors are secured open.

⚠ CAUTION

Keep the generator set and the surrounding area clean and free from obstructions. Remove any debris from the set and keep the floor clean and dry.

NOTICE

Keep multi-class ABC fire extinguishers handy. Class A fires involve ordinary combustible materials such as wood and cloth. Class B fires involve combustible and flammable liquid fuels and gaseous fuels. Class C fires involve live electrical equipment. (Refer to NFPA No. 10 in applicable region.)

2.2 Generator Set Safety Code

Before operating the generator set, read the manuals and become familiar with them and the equipment. **Safe and efficient operation can be achieved only if the equipment is properly operated and maintained.** Many accidents are caused by failure to follow fundamental rules and precautions.

⚠ WARNING

Improper operation and maintenance can lead to severe personal injury, or loss of life and property, by fire, electrocution, mechanical breakdown, or exhaust gas asphyxiation. Read and follow all Safety Precautions, Warnings, and Cautions throughout this manual and the documentation supplied with your generator set.

⚠ WARNING

Lifting and repositioning of the generator set must only be carried out using suitable lifting equipment, shackles, and spreader bars, in accordance with local guidelines and legislation, by suitably trained and experienced personnel. Incorrect lifting can result in severe personal injury, death, and/or equipment damage. For more information, contact your authorized distributor.

2.3 Electrical Shocks and Arc Flashes Can Cause Severe Personal Injury or Death

⚠ WARNING

Any work with exposed energized circuits with potentials of 50 Volts AC or 75 Volts DC or higher poses a significant risk of electrical shock and electrical arc flash. These silent hazards can cause severe injuries or death. Refer to standard NFPA 70E or equivalent safety standards in corresponding regions for details of the dangers involved and for the safety requirements.

Guidelines to follow when working on de-energized electrical systems:

- Use proper PPE. Do not wear jewelry and make sure that any conductive items are removed from pockets as these items can fall into equipment and the resulting short circuit can cause shock or burning. Refer to standard NFPA 70E for PPE standards.

- De-energize and lockout/tagout electrical systems prior to working on them. Lockout/Tagout is intended to prevent injury due to unexpected start-up of equipment or the release of stored energy. Please refer to the lockout/tagout section for more information.
- De-energize and lockout/tagout all circuits and devices before removing any protective shields or making any measurements on electrical equipment.
- Follow all applicable regional electrical and safety codes.

Guidelines to follow when working on energized electrical systems:

NOTICE

It is the policy of Cummins Inc. to perform all electrical work in a de-energized state. However, employees or suppliers may be permitted to occasionally perform work on energized electrical equipment only when qualified and authorized to do so and when troubleshooting, or if de-energizing the equipment would create a greater risk or make the task impossible and all other alternatives have been exhausted.

NOTICE

Exposed energized electrical work is only allowed as per the relevant procedures and must be undertaken by a Cummins authorized person with any appropriate energized work permit for the work to be performed while using proper PPE, tools and equipment.

In summary:

- Do not tamper with or bypass interlocks unless you are authorized to do so.
- Understand and assess the risks - use proper PPE. Do not wear jewelry and make sure that any conductive items are removed from pockets as these items can fall into equipment and the resulting short circuit can cause shock or burning. Refer to standard NFPA 70E for PPE standards.
- Make sure that an accompanying person who can undertake a rescue is nearby.

3 Instruction

3.1 Installation of Enclosure Kit

This instruction sheet describes the installation of the enclosure kit as shown in [Figure 1](#).

Read these installation instructions completely and become familiar with safety warnings, cautions and installation procedure before starting.

1. Make sure there is no debris in the mounting holes prior to installation.
2. Make sure the sloped end of the inlet duct is on top, as shown in [Figure 2](#).
3. Bolt the inlet duct to the enclosed generator set.
4. Tighten the bolts. Torque to 10 - 12 Nm (7 - 9 ft-lbs).

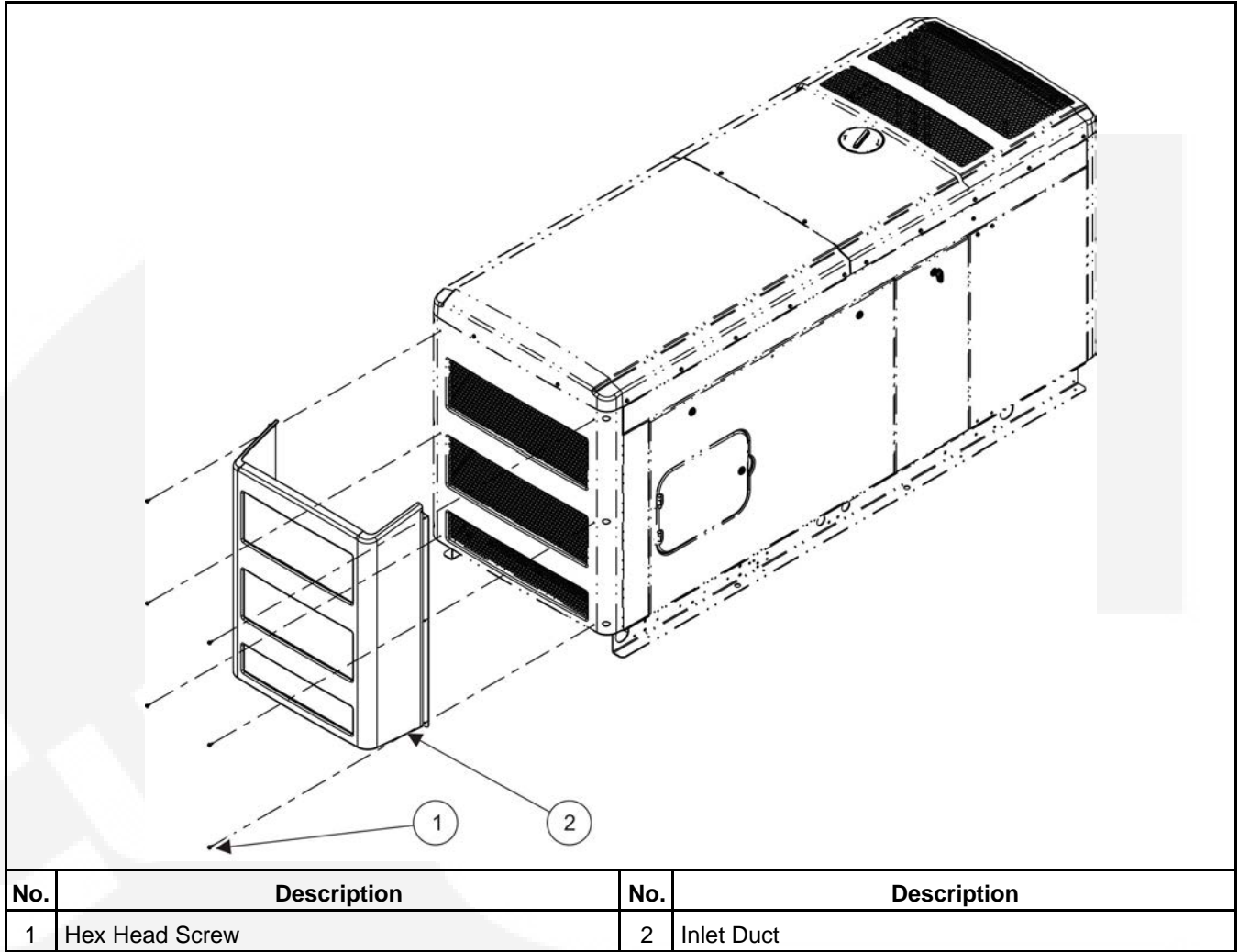

FIGURE 1. ENCLOSURE KIT ATTACHED TO GENERATOR SET

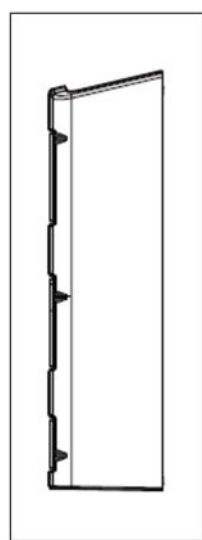
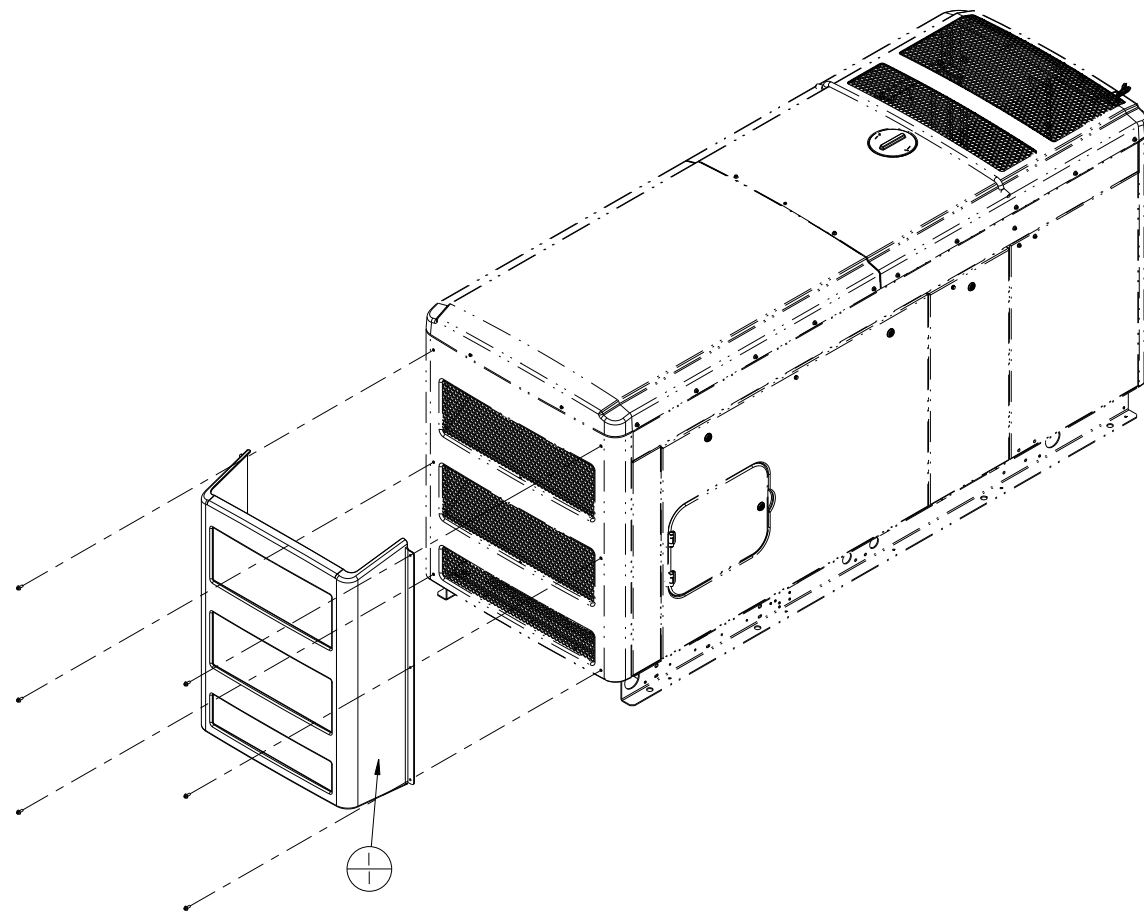

FIGURE 2. INLET DUCT WITH SLOPED END ON TOP

REL NO	LTR	NO	REVISION	OWN	CAD	APVD	DATE
ECO-138682	D	1	RMV INSTRUCTION SHEET A046J596	AK	NK	J.MATTHEWS	15OCT13

NOTES:

1. TORQUE TO 9.8 - 11.9 Nm
2. MAKE SURE THERE IS NO DEBRIS IN MOUNTING HOLES PRIOR TO INSTALLATION.



-THIS IS A CONTROLLED ITEM-
 PER CPG PROCEDURE FRE-1002
 TO MAINTAIN COMPLIANCE WITH REQUIREMENTS OF THE CODES, STANDARDS, OR AGENCIES LISTED BELOW
 CSA IN CE RVIA ABYC
 IBC OTHER - OSAPD OTHER
 CHANGES, DEVIATIONS, OR SUBSTITUTIONS OF MATERIAL, PROCESS, OR PERFORMANCE FOR THIS ITEM MUST BE APPROVED BY THE FOLLOWING CONTROLLED ITEM APPROVER
 RESPONSIBLE CIA ROLE: STATIONARY GENSET CIA
 RESPONSIBLE CIA ROLE: SEISMIC

UNLESS OTHERWISE SPECIFIED, ALL DIMENSIONS ARE IN MILLIMETERS

CH	TOL	ROLE	MIN	MAX
X	± 1		0.00- 4.99	+0.15/-0.08
.X	± 0.8		5.00- 9.99	+0.20/-0.10
.XX	± 0.38		10.00-17.49	+0.25/-0.13
			17.50-24.99	+0.30/-0.13

ANG TOL: ± 0.5° SCALE: 1/10

SIM 10	NONE	OWN	V.PASARAD
DO NOT SCALE PRINT		CAD	T.RADKE
		APVD	J.MATTHEWS
		DATE	07DEC12

CUMMINS POWER GENERATION	
KIT, ENCLOSURE	
SI-S2 UPGRADE	
SITE CODE	PGF
REV	D
NO	A043J733
SHEET	1 OF 1
REV	D

- CONFIDENTIAL -
 PROPERTY OF CUMMINS
 POWER GENERATION GROUP
 FOR INTERPRETATION OF DIMENSIONS AND TOLERANCING, SEE ASME Y14.5M-1994
 FIRST USED ON ARROW



Battery Charger-6 Amp

A045D925 60Hz/50Hz



Description

Cummins® fully automatic battery chargers are designed to both recharge your batteries, and extend your battery's life in applications where it is stored for long periods of time. This charger can handle poor power quality, exposure to extreme weather and rough handling.

To maximize battery life, a 3-stage charging cycle is implemented. The three charging stages are bulk stage, absorption stage and maintenance stage. During the bulk stage, the charger uses its full amp output to do the heaviest charging, quickly bringing your battery to about 75% of capacity. In the absorption stage, the current slows, adjusting for maximum charging efficiency while it gently tops off the battery to about 98% of capacity.

During the maintenance stage, a lower, closely-regulated, constant voltage is applied to maintain full charge and prevent discharge.

Unlike some "trickle chargers," the float charger won't apply more current than necessary to maintain full charge. Batteries can be connected indefinitely, without harm; in fact, the float charge extends battery life.

Features

Protection – Surge protected to IEEE and EN standards. All models include single pole cartridge type fuses mounted on the printed circuit board to protect against input or output overcurrent.

Lightweight and Silent – Lighter than transformer types, completely silent but still provides full output when overloaded outlets drop AC voltage below the normal 115V.

Monitoring – Status LED indicators are provided to show the condition or charging status of the battery. When the red LED is on, it indicates that the battery is discharged and is recharging at the 'BULK' rate. When both the red and green LEDs are on, the battery is charging at the 'midrange' rate. When the green LED is on, the battery is 90% charged and ready for use.

Construction – Made using epoxy-potted cases making it the ultimate in durability, completely waterproof and able to withstand numerous caustic chemicals and gases, as well as being shockproof.

Fault Indication – The charger senses and indicates the following fault conditions: Defective or damaged cells, under-voltage at the battery, battery drawing more current than charger can replace, loss of power or extremely low AC voltage at the charger, other battery fault conditions and charger failure.

Compatibility – Works with Sealed Lead Acid (SLA), Absorbed Glass Mat (AGM) and Gel type batteries.

Low Electromagnetic and Radio

Frequency Interference – This product meets FCC class B for conducted and radiated emissions.

Listed – This product is UL listed according to the UL 1236 Standard.

Warranty – This product has a two year warranty

Specifications

Performance and Physical Characteristics

Output:	Nominal voltage	12 VDC
	Float voltage – 12 V batteries	13.0-13.6 VDC at 0-2 amps
	Maximum output current	6 A @ 12 VDC nom
Input:	Voltage AC	115, 208, 240 ±10%, 90-135
	Frequency	60 Hz ±5%
Battery:	Maximum battery size	150 Amp Hours
	Maximum recharge time	20 hours
Approximate net weight		4 lbs. (1.81 Kg)
Approximate dimensions: height x width x depth-in(mm)		2.25 x 6.4 x 3.5 (57 x 162 x 89)
Ambient temperature operation: At full rated output		-40°F to 122 °F (-40 °C to 50 °C)



Warning: Back feed to a utility system can cause electrocution and/or property damage. Do not connect generator sets to any building electrical system except through an approved device or after building main switch is open.

Warning: For professional use only. Must be installed by a qualified service technician. Improper installation presents hazards of electrical shock and improper operation, resulting in severe personal injury and/or property damage.

For more information contact your local Cummins distributor
or visit power.cummins.com

Our energy working for you.™



4	3	2	1
0541_0833	B	Pro/ENGINEER	METRIC DWG
REL NO	LTR	NO	REVISION
FRD12374	A	1	PRODUCTION_RELEASE
ZONE	DR	CHKR	APPROVED
-	MTA	EN	EN
			DATE
			03-19-02

NOTE:

THIS KIT PROVIDES A 3/4" FLEXIBLE GASEOUS (NG/LPV) FUEL CONNECTION. THAT TAKES UP MOVEMENT AND VIBRATION OF THE GENERATOR SET. SEE INSTRUCTION SHEET FOR INSTALLATION GUIDELINES.

1	5	G542	-	INSTRUCTION SHEET
1	4	0518_0601	-	PIPE SEALANT (6ML)
1	3	0505_0102	-	NIPPLE-CLOSE (3/4 X 1-3/8)
2	2	0505_1375	-	ELBOW-45 DEG (3/4 NPT)
1	1	0501_0776-02	C	LINE-FUEL (FLEX)

QTY	ITEM	PART NO	DWG SIZE	DESCRIPTION OR MATERIAL	REF DES
	DR	TABEL	03-19-02	NAME	DATE
	CHKR	F_C_DEMEIRELES	03-19-02	NAME	DATE
	APPROVED	E_NORDSTROM	03-19-02	NAME	DATE
	FOR INTERPRETATION OF DIMENSIONING AND TOLERANCING, SEE ANSI Y14.5M-1982	MODEL FIRST USED ON	GG	SITE CODE	PGA

DO NOT SCALE PRINT
 ANG TOL ± 1.0°
 DRAWN TO SCALE OF 1/1

TOLERANCE UNLESS OTHERWISE SPECIFIED		SIM TO	
mm	Inch	COPIED FROM	
X ± I .X ± 0.8 .XX ± 0.38	.X ± .XX ± .XXX ±	THIRD ANGLE PROJECTION	
HOLE		THIS DOCUMENT IS THE PROPERTY OF CUMMINS POWER GENERATION. IT CONTAINS PROPRIETARY AND CONFIDENTIAL INFORMATION WHICH MUST NOT BE DUPLICATED, USED OR DISCLOSED OTHER THAN EXPRESSLY AUTHORIZED BY CUMMINS POWER GENERATION OR ITS REPRESENTATIVE	
0.09- 4.99	+0.15/-0.08	.004-.200	+ .006/- .003
5.00- 9.99	+0.20/-0.10	.201-.421	+ .008/- .004
10.00-17.49	+0.25/-0.13	.422-.703	+ .010/- .005
17.50-24.99	+0.30/-0.13	.704-.999	+ .012/- .005



CUMMINS POWER GENERATION
 1400 73RD AVE NE
 MINNEAPOLIS, MINNESOTA 55432

TITLE
FUEL_SYSTEM_KIT (3/4")

DWG NO
0541_0833

SHEET
 1 OF 1
 DWG SIZE
B

Gaseous Fuel Hose Kits 541-0832 (1/2"), 541-0833 (3/4"), 541-0834 (1"), and 541-0835 (1-1/4")

GENERAL INFORMATION

This instruction sheet describes how to install the gaseous fuel hose kit. The flexible fuel hose must be used for connections at the engine to take up generator set movement and vibration.

Read these installation instructions completely and become familiar with safety warnings, cautions and installation procedure before starting.

⚠ WARNING *Ignition of explosive battery gases can cause severe personal injury or death. Arcing at battery terminals, light switch or other equipment, flame, pilot lights and sparks can ignite battery gas. Do not smoke, or switch trouble light ON or OFF near battery. Discharge static electricity from body before touching batteries by first touching a grounded metal surface.*

Ventilate battery area before working on or near battery—Wear goggles—Stop genset and disconnect charger before disconnecting battery cables—Disconnect negative (–) cable first and reconnect last.

⚠ CAUTION *Disconnect battery charger from AC source before disconnecting battery cables. Otherwise, disconnecting cables can result in voltage spikes damaging to DC control circuits of the set.*

⚠ WARNING *Accidental starting of the generator set can cause severe personal injury or death. Prevent accidental starting by disconnecting the negative (–) cable from the battery terminal.*

⚠ WARNING *Gaseous fuels are flammable and explosive and can cause severe personal injury or death. Do not allow cigarettes, flame, pilot lights, arcing switches or equipment in area or areas sharing ventilation. Keep a type ABC fire extinguisher handy.*

Natural gas is lighter than air, and will tend to gather under hoods. LPG is heavier than air, and will tend to gather in sumps or low areas. NFPA Standard No. 58 requires all persons handling and operating LPG to be trained in proper handling and operating procedures.

The fuel supply system must not leak. The installation, inspection and testing of the fuel supply system must be done by qualified persons according to applicable codes.

Additional parts are provided in this kit to allow for site flexibility. Use of all parts supplied may not be required to complete the installation of the fuel hose. The kit contains the following parts.

- One Gaseous Fuel Hose (with manufactures installation instructions/recommendations).
- Two Pipe Elbows
- One Close Nipple
- One Thread Sealant (6 ml)

Use thread sealant on all pipe threads when assembling.

1. Disconnect the battery charger (if applicable). Remove all electrical supply sources.
2. Disconnect the negative (–) cable from the battery to prevent accidental starting.
3. Shut off the fuel supply and remove necessary fuel supply piping to allow installation of the flexible fuel hose.

4. Install the fuel hose between the fuel supply piping and the fuel inlet fitting of the genset. Adhere to hose manufacturer's installation instructions when installing the hose. (When properly installed, the hose should be bent to the 90° in the radius shown to allow for movement in any direction). If necessary, use elbows and close nipples to achieve 90°.
5. The pipe union (on one end of the fuel hose) is used to prevent twisting of the flexible fuel hose when completing the connection between the fuel supply line and the genset. This pipe union should be the last fitting tightened in the fuel line assembly.
6. Open the manual supply shutoff valve and check for fuel system leaks. **If there is a fuel leak, close valve immediately and fix leak.**

7. Connect the negative (-) cable to the battery.
8. Connect the battery charger (if applicable).
9. Installer should start set and check flexible fuel hose for resonance. If excessive vibration occurs, return to step 1 and provide additional support to fuel supply piping.
10. Routinely inspect hose after operation to ensure it is functioning properly.

TABLE 1. DIMENSIONS FOR FIGURE 1

TUBE	LGTH	DIM A	DIM B	DIM C	DIM D
1/2"	20.5	8"	12"	5.2"	17"
3/4"	24"	10"	14"	5.8"	19.8"
1"	27"	12"	16"	6.3"	22.6"
1-1/4"	31-1/2"	15"	19"	7.2"	26.9"

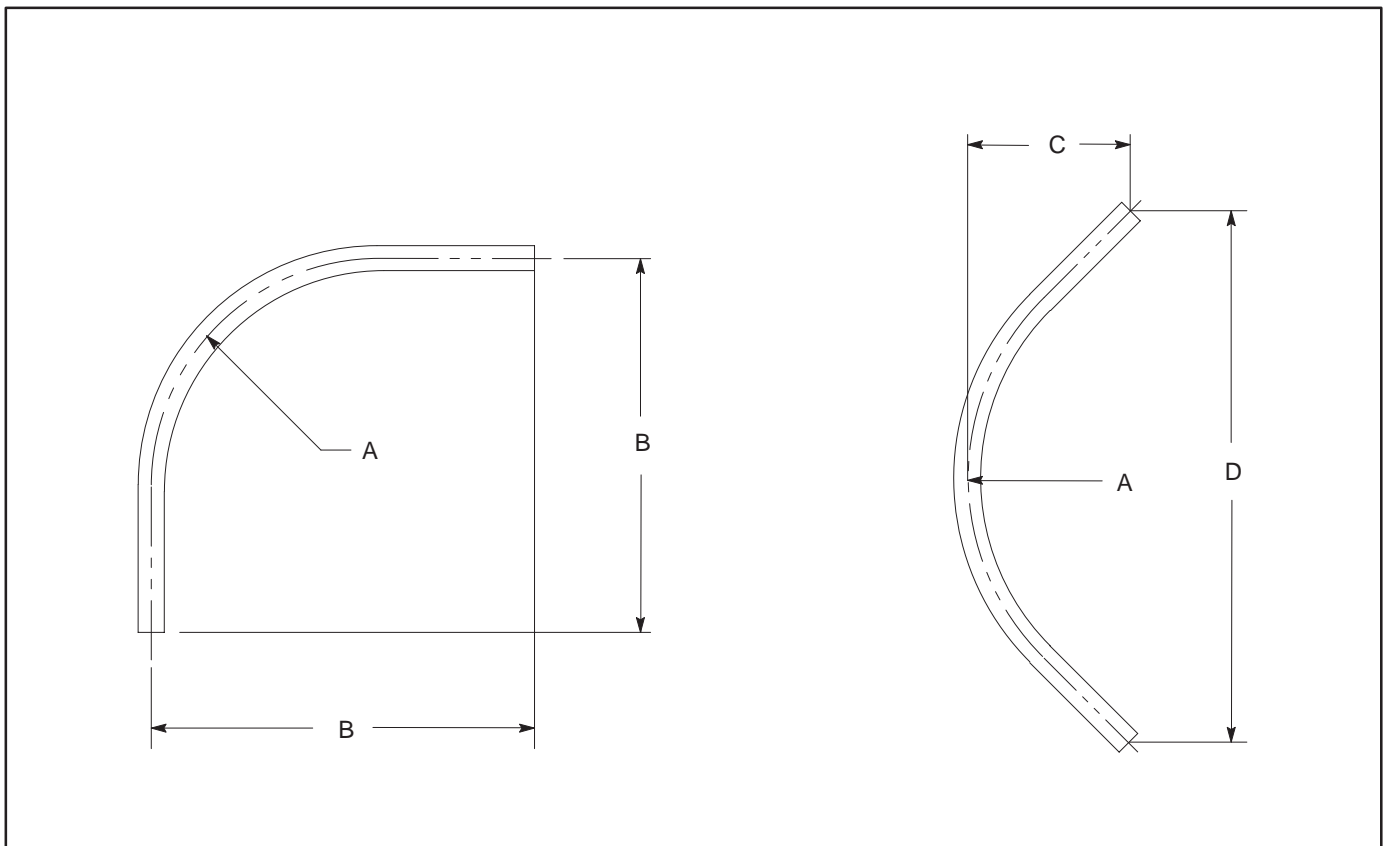

FIGURE 1. INSTALLATION OF GASEOUS FUEL HOSE

SECTION 4

Generator Drawings



- NOTES:**
1. DIM [] IN INCHES
 2. 120° AND 170° ARE DETENTED OPEN ANGLE OF HINGE.
 3. WHEN HOUSING IS INSTALLED ON AN OPEN GENERATOR SET, THE TOTAL WEIGHT WILL INCREASE BY 84 KG (185 LBS). THIS INCLUDES THE MUFFLER.
 4. THE CENTER OF GRAVITY (CG) OF THE GENERATOR SET WHEN EQUIPPED WITH THIS HOUSING SHIFTS APPROXIMATELY 51MM (2 INCH) TOWARDS THE AIR DISCHARGE END OF HOUSING AND 42MM (1.5 INCH) FROM THE GROUND. COMPARED TO THE EQUIVALENT NON-HOUSED PRODUCT WITH THE F179 SKID. SEE HOUSING READY SKID BASE OUTLINE DRAWING FOR CG LOCATION OF NON HOUSED PRODUCT.

REL NO	LTR	NO	REVISION	DWN	CKD	APVD	DATE
ECO-178681	E	1	ZONE A4; F231-2 AND F216-2... CONFIGURATIONS WAS F231-2 ...	--	--	--	--
			CONFIGURATION	PPP	KAMM	WINGFIELD	09JUL18
		2	UPDATE VIEWS PICTORIALY	PPP	KAMM	WINGFIELD	09JUL18

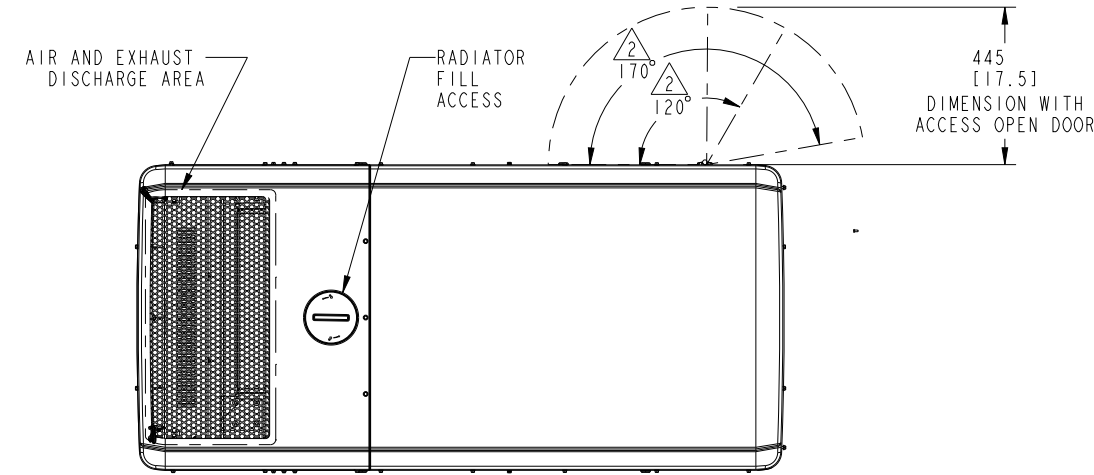

TOP VIEW

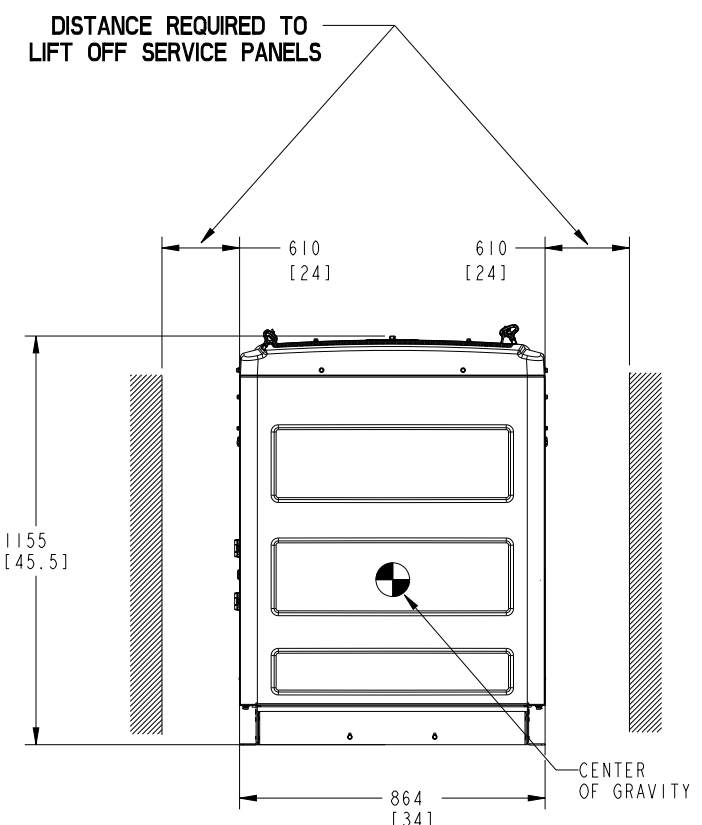

OUTLET VIEW

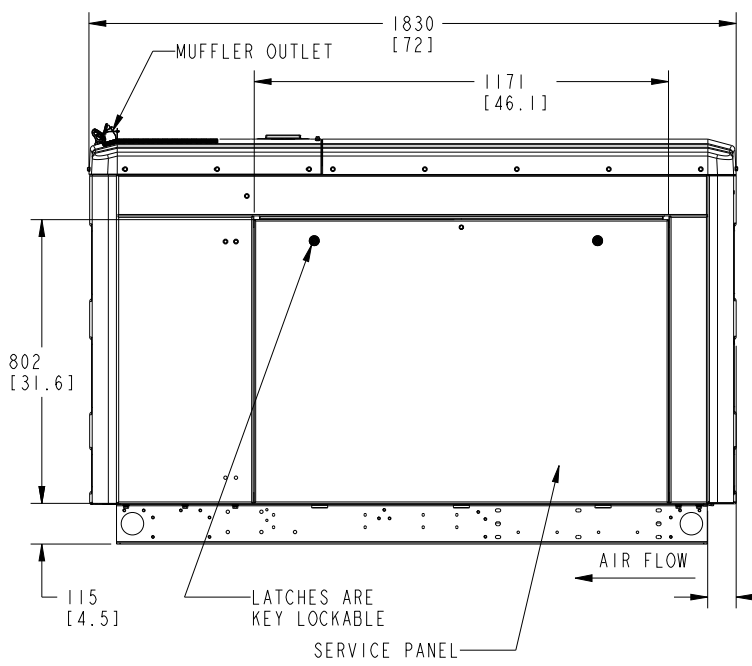

LEFT SIDE VIEW

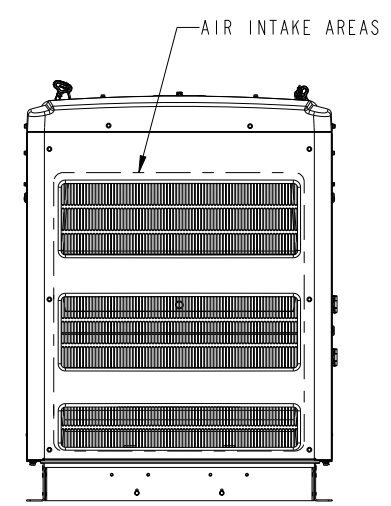

INLET VIEW

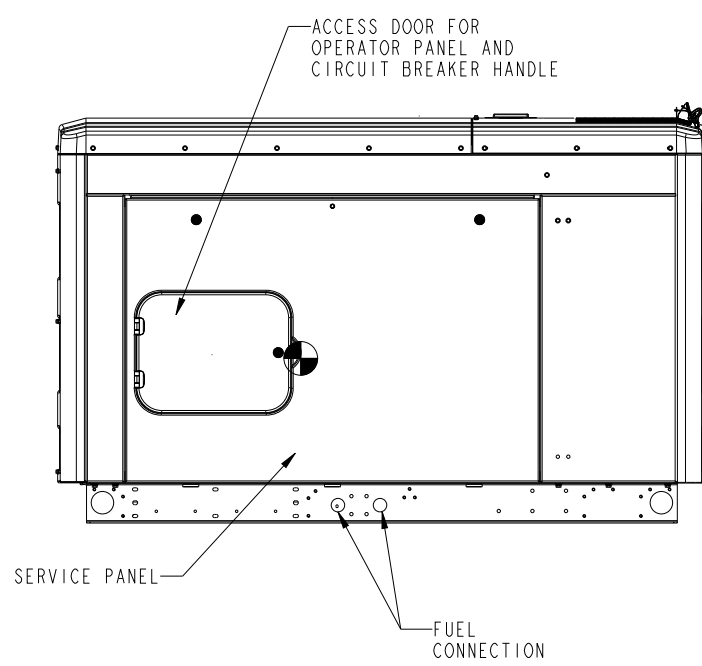

RIGHT SIDE VIEW

F231-2 AND F216-2 ENCLOSURE CONFIGURATIONS

UNLESS OTHERWISE SPECIFIED, ALL DIMENSIONS ARE IN MILLIMETERS		SH TO NONE	DWN S_GAMBHIRE		CUMMINS POWER GENERATION	
DIM	TOLERANCE	DO NOT SCALE PRINT	CKD T_RADKE		OUTLINE, ENCLOSURE	
X ± 1	0.00-4.99 +0.15/-0.08		APVD J_MATTHEWS	SITE CODE	PGF	
.X ± 0.8	5.00-9.99 +0.20/-0.10		DATE 17JAN13	DWG FILE	A043U604	
.XX ± 0.38	10.00-17.49 +0.25/-0.13		FIRST USED ON	SHEET	1 of 2	
ANG TOL: ± 0.5°	17.50-24.99 +0.30/-0.13	PROPERTY OF CUMMINS POWER GENERATION GROUP	SCALE: 1/10	REV	E	

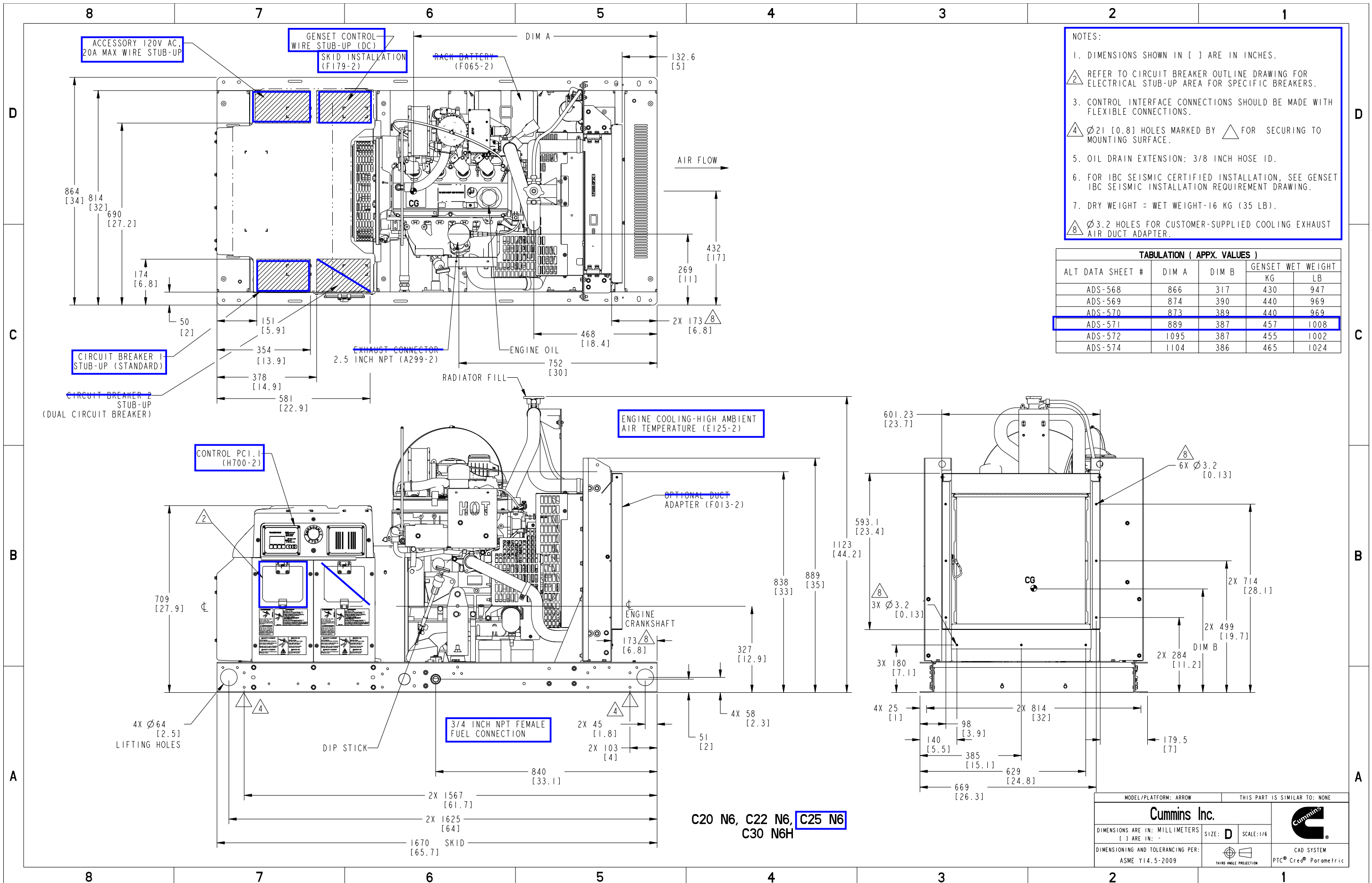

- NOTES:
1. DIMENSIONS SHOWN IN [] ARE IN INCHES.
 2. REFER TO CIRCUIT BREAKER OUTLINE DRAWING FOR ELECTRICAL STUB-UP AREA FOR SPECIFIC BREAKERS.
 3. CONTROL INTERFACE CONNECTIONS SHOULD BE MADE WITH FLEXIBLE CONNECTIONS.
 4. Ø21 [0.8] HOLES MARKED BY △ FOR SECURING TO MOUNTING SURFACE.
 5. OIL DRAIN EXTENSION: 3/8 INCH HOSE ID.
 6. FOR IBC SEISMIC CERTIFIED INSTALLATION, SEE GENSET IBC SEISMIC INSTALLATION REQUIREMENT DRAWING.
 7. DRY WEIGHT = WET WEIGHT-16 KG (35 LB).
 8. Ø3.2 HOLES FOR CUSTOMER-SUPPLIED COOLING EXHAUST AIR DUCT ADAPTER.

TABULATION (APPX. VALUES)

ALT DATA SHEET #	DIM A	DIM B	GENSET WET WEIGHT	
			KG	LB
ADS-568	866	317	430	947
ADS-569	874	390	440	969
ADS-570	873	389	440	969
ADS-571	889	387	457	1008
ADS-572	1095	387	455	1002
ADS-574	1104	386	465	1024

MODEL/PLATFORM: ARROW THIS PART IS SIMILAR TO: NONE

Cummins Inc.

DIMENSIONS ARE IN: MILLIMETERS [] ARE IN: -

DIMENSIONING AND TOLERANCING PER: ASME Y14.5-2009

SIZE: D SCALE: 1/4



THIRD ANGLE PROJECTION

CAD SYSTEM: PTC® Creo® Parametric

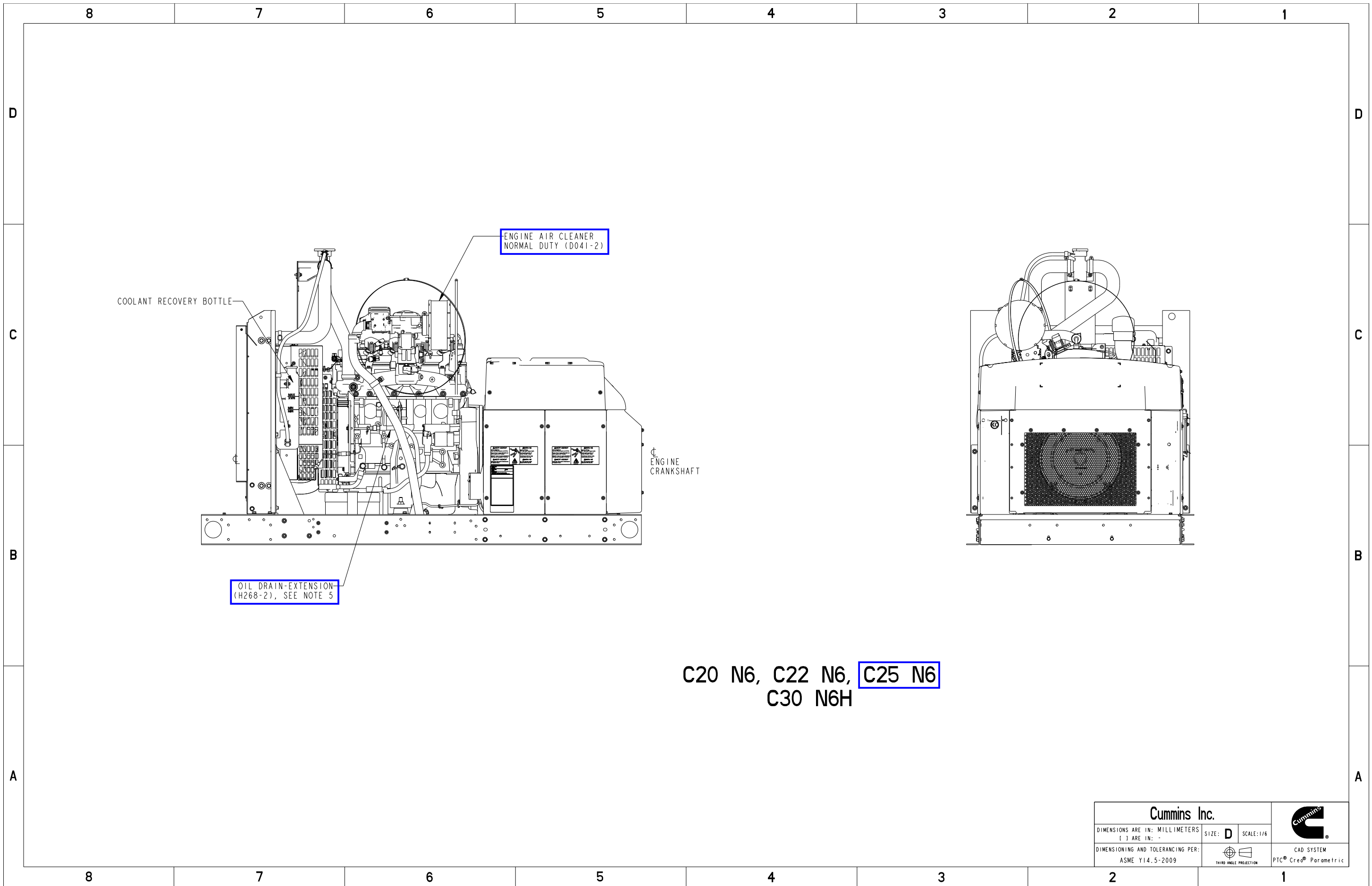
C20 N6, C22 N6, C25 N6, C30 N6H



C20 N6, C22 N6, **C25 N6**
 C30 N6H

Cummins Inc.		
DIMENSIONS ARE IN: MILLIMETERS [] ARE IN: "	SIZE: D SCALE: 1/4	
DIMENSIONING AND TOLERANCING PER: ASME Y14.5-2009	 THIRD ANGLE PROJECTION	CAD SYSTEM PTC® Creo® Parametric

Cummins Data Classification:
Cummins Confidential

This document (and the information shown thereon) is **Confidential and Proprietary** and shall not be disclosed to others in hard copy or electronic form, reproduced by any means, or used for any purpose without written consent of Cummins Inc.

Part Number: **A045C211** Part Revision: **F**
 Part Name: **OUTLINE,GENSET**
 Drawing Category: **Detail** State: **Released** Sheet 2 of 3

Document Generated: 14FEB2024 18:45 GMT

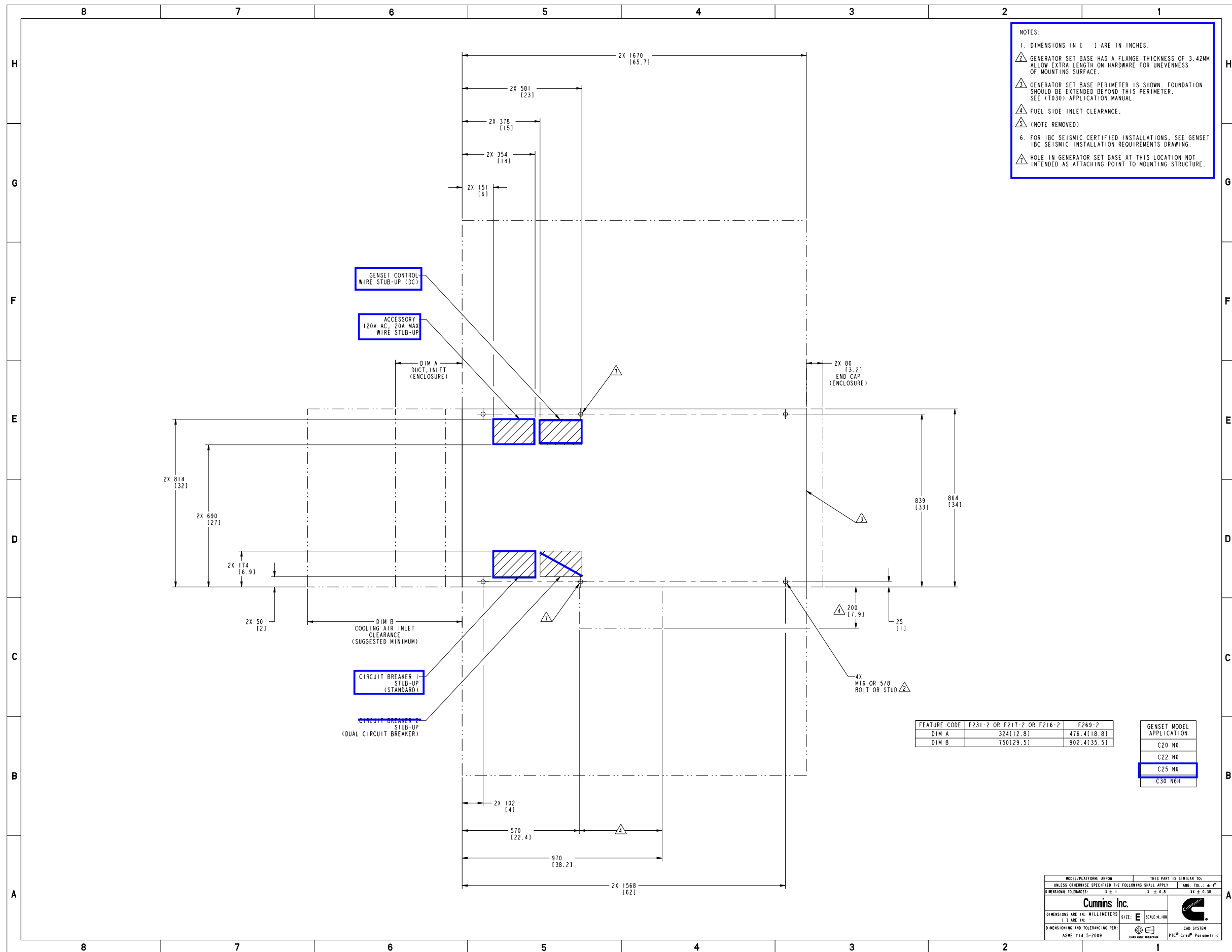

Document Generated: 13MAY2021 14:20 GMT

REL NO	LTR	NO	REVISION	DWN	CKD	APVD	DATE
ECO-149443	E	1	ZONE D4; ADDED VIEW TO SHOW LARGER BATTERY TRAY OPTION (F253-2)	-	-	-	-
		2	ZONE A2; 500W COOLANT HTR OPTION WAS (H036-2), ADDED 1000W COOLANT HTR OPTION (E154-2)	-	-	-	-
		3	SEE SHEET 2	DKS	MMJM	JAWALE	20 JAN 15
		4	SEE SHEET 2	DKS	MMJM	JAWALE	20 JAN 15
		5	SEE SHEET 3	DKS	MMJM	JAWALE	20 JAN 15
		6	SEE SHEET 3	DKS	MMJM	JAWALE	20 JAN 15

NOTES:
 1. (NOTE REMOVED)
 2. (NOTE REMOVED)

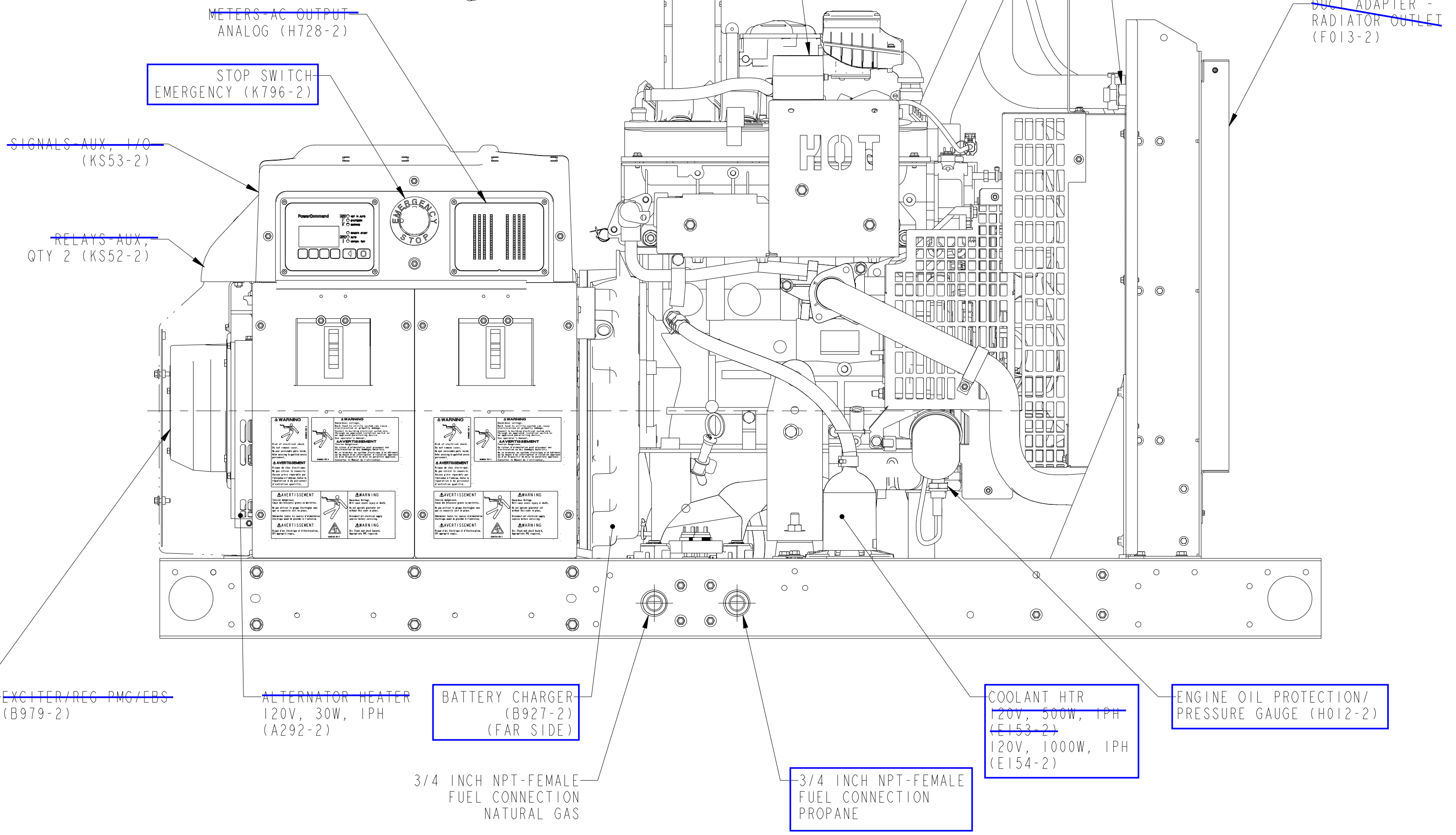
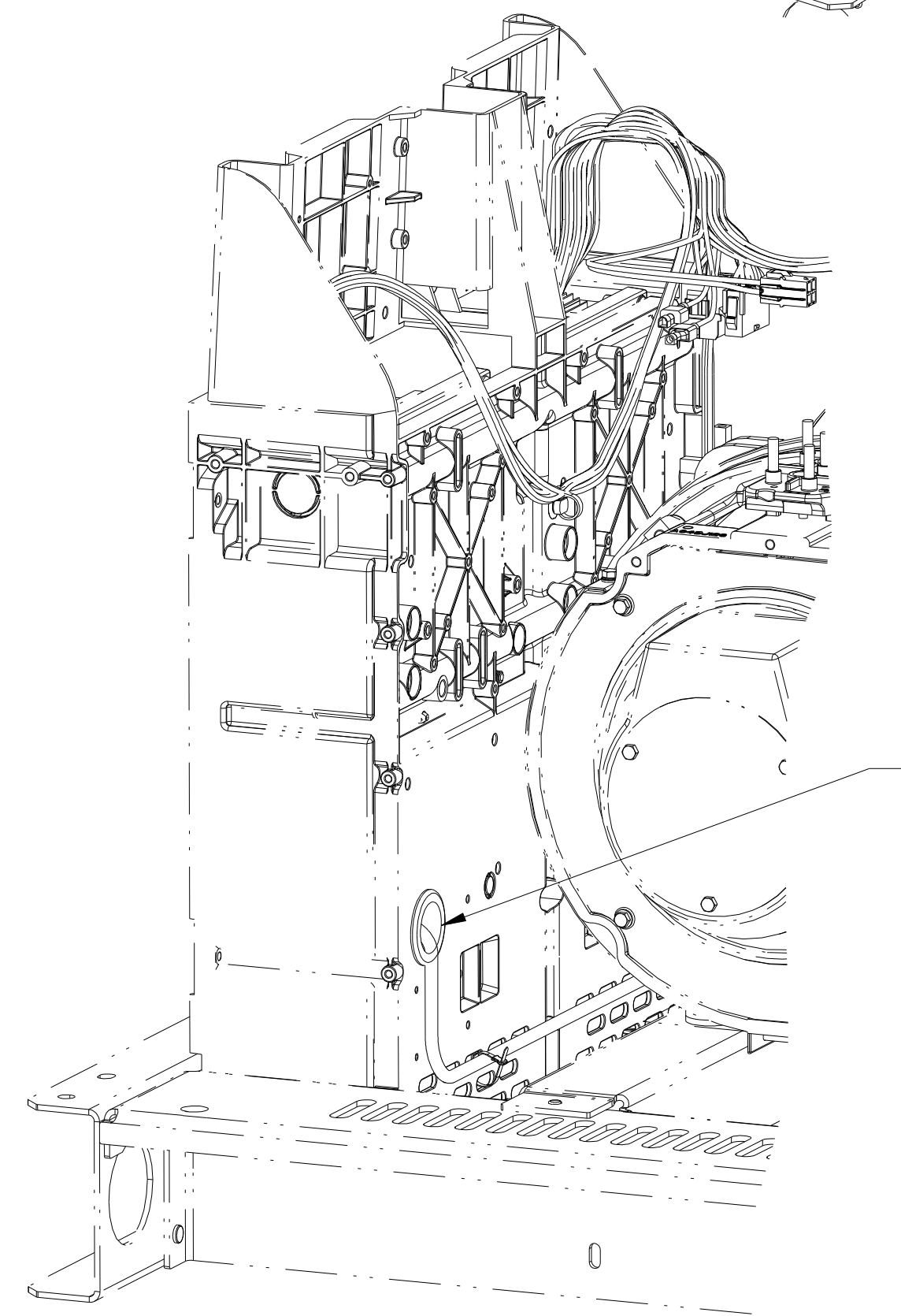
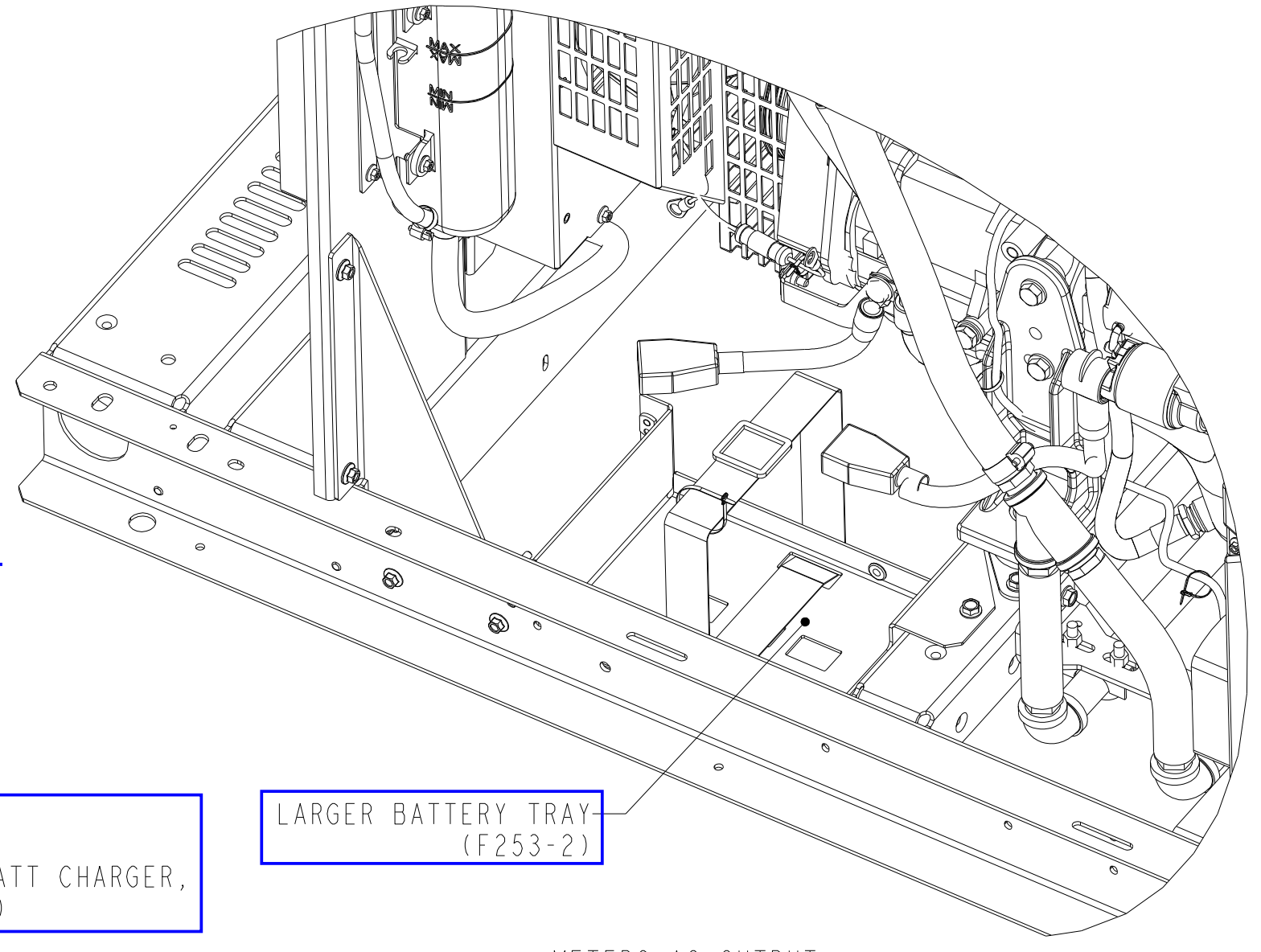
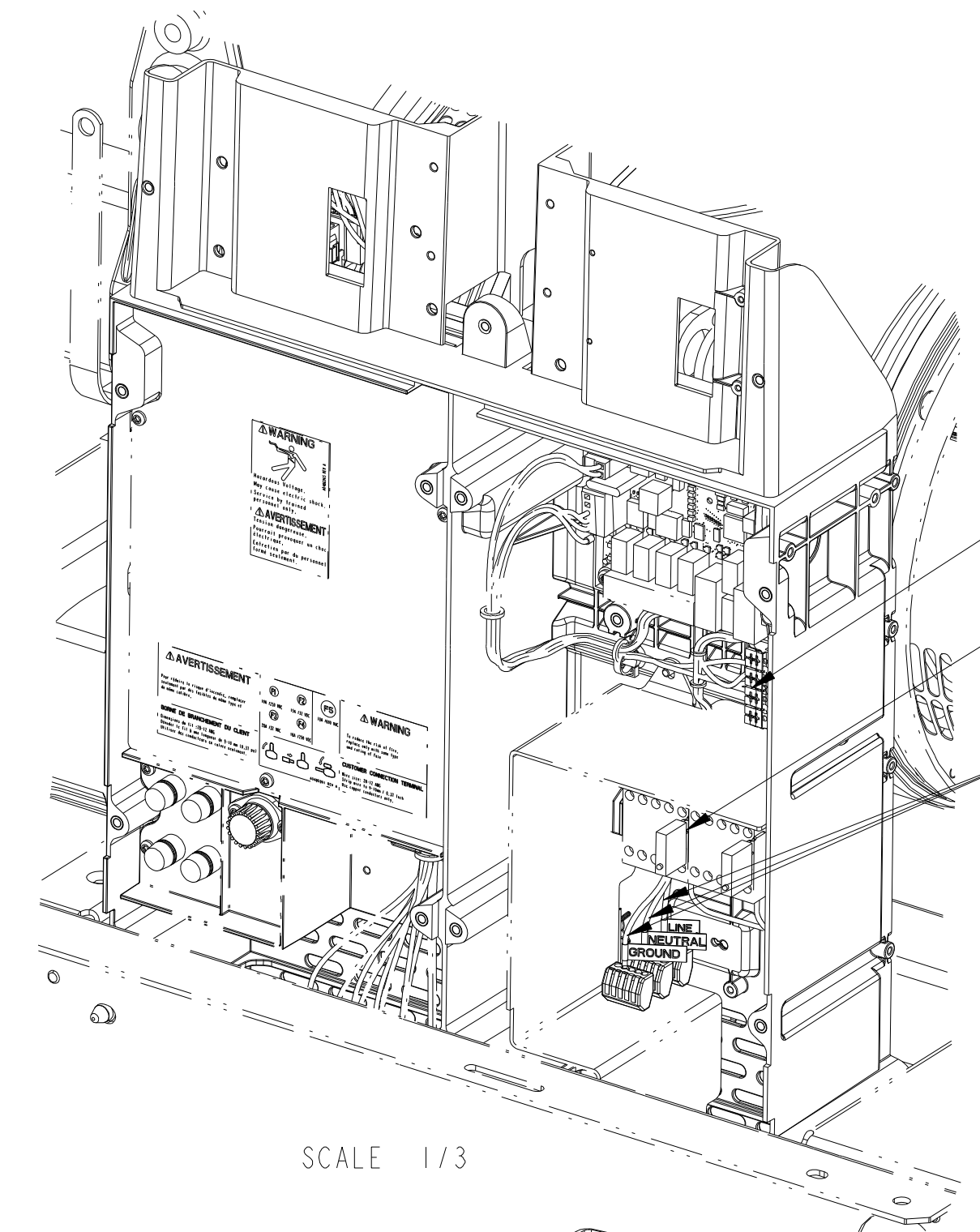

C20 N6, C22 N6, **C25 N6**, C30 N6H

UNLESS OTHERWISE SPECIFIED, ALL DIMENSIONS ARE IN MILLIMETERS		SIM TO NONE	DWN C_BADGUJAR		CUMMINS POWER GENERATION	
DO NOT SCALE PRINT		CKD S_DULAM	OUTLINE, GENSET OPTIONS			
DATE 10 JUN 13		APVD D_GILLETT	SITE CODE		SHEET 1 OF 3	
ANG TOL: ± 0.5°		SCALE: 1/4	PGF	DWG REV E		
DIM X ± 1 0.00- 4.99 +0.15/-0.08 .X ± 0.8 5.00- 9.99 +0.20/-0.10 .XX ± 0.38 10.00-17.49 +0.25/-0.13 .XXX ± 0.38 17.50-24.99 +0.30/-0.13		CONFIDENTIAL PROPERTY OF CUMMINS POWER GENERATION GROUP FOR INTERPRETATION, FIRST USED ON OF DIMENSIONING AND TOLERANCING, SEE ASME Y14.5M-1994	ARROW	A045C215		

**SINGLE BREAKER
(H-FRAME SHOWN)**

"A" POSITION ONLY

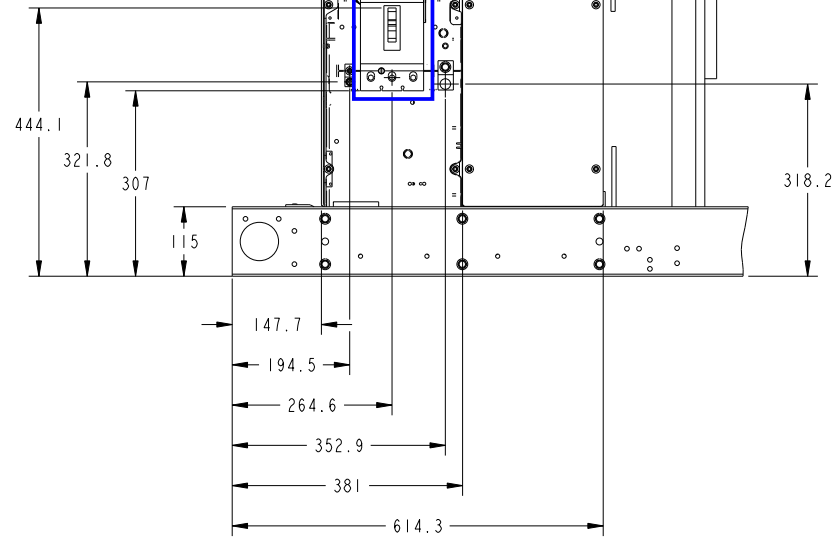

SIDE VIEW

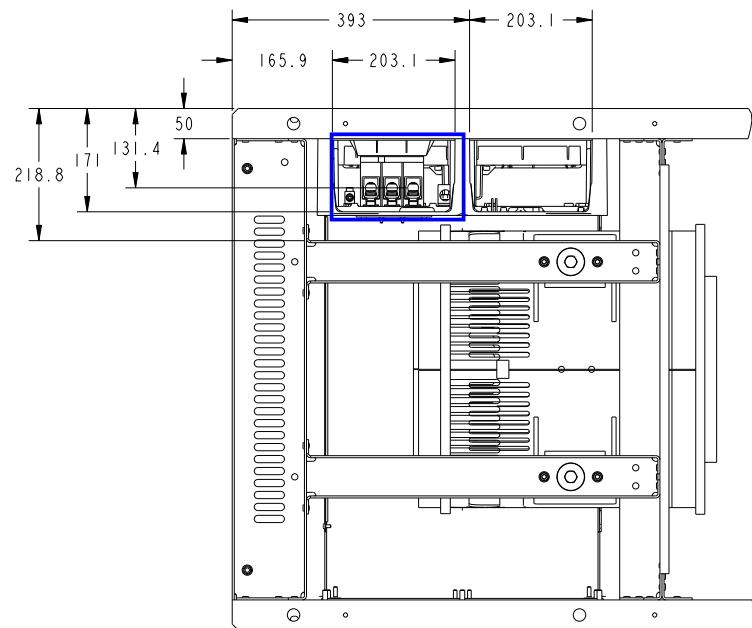

BOTTOM VIEW

**DUAL BREAKER
(J-FRAME SHOWN)**

"A" POSITION

"B" POSITION

Not applicable on this system

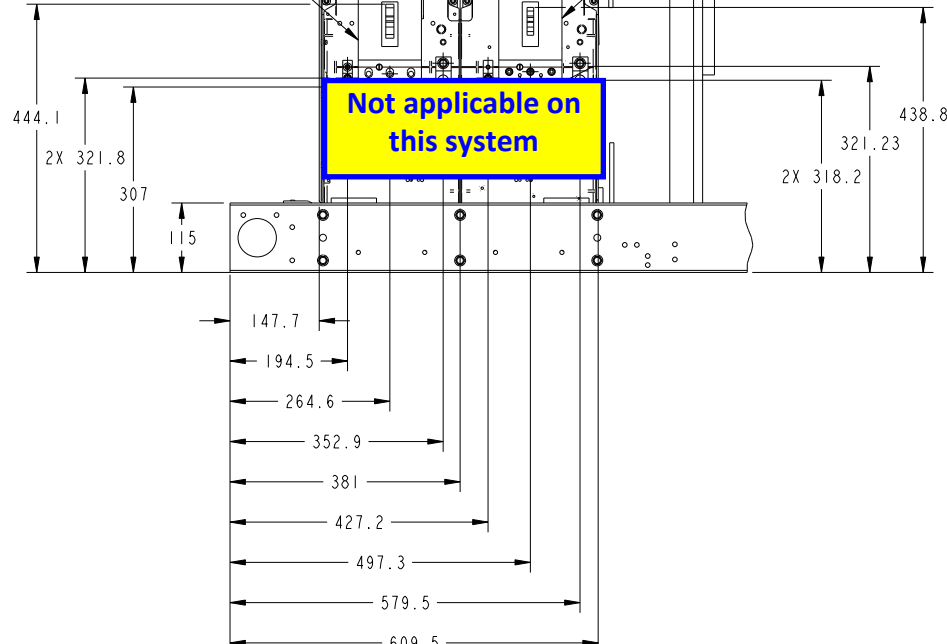

SIDE VIEW

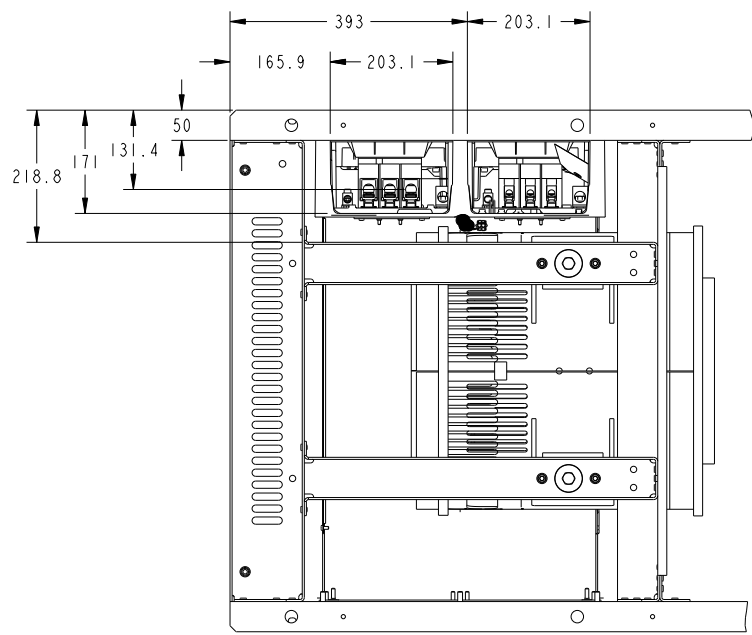

BOTTOM VIEW

REL NO	LTR	NO	REVISION	OWN	CAD	APVD	DATE
ECO-134624	B	1	PRODUCTION RELEASE	SP	PL	P_LARSON	13MAY13
		2	DRAWING HAS BEEN PICTORIALY UPDATED	SP	PL	P_LARSON	13MAY13
		3	ZONE (D3) ADD PHRASE "(J-FRAME SHOWN)"	SP	PL	P_LARSON	13MAY13
		4	ZONE (D5) ADD PHRASE "(J-FRAME SHOWN)"	SP	PL	P_LARSON	13MAY13
		5	ZONE (D3) ADD PHRASE "B" POSITION	SP	PL	P_LARSON	13MAY13
		6	ZONE (D4) ADD PHRASE "A" POSITION	SP	PL	P_LARSON	13MAY13
		7	ZONE (D6) ADD PHRASE "A" POSITION ONLY	SP	PL	P_LARSON	13MAY13
		8	ADD C11 LABEL	SP	PL	P_LARSON	13MAY13
		9	ZONE (D6) DIM 444.1 WAS 417.2	SP	PL	P_LARSON	13MAY13
		10	ZONE (D4) DIM 444.1 WAS 417.2	SP	PL	P_LARSON	13MAY13
		11	ZONE (D2) DIM 438.8 WAS 412.26	SP	PL	P_LARSON	13MAY13
		12	ADD SIM TO NONE	SP	PL	P_LARSON	13MAY13

CIRCUIT BREAKER ACCESSORIES

1	SHUNT TRIP (MX) 12 VDC COIL BURDEN < 5 WATTS 10 AMP IN-RUSH
2	AUXILIARY CONTACTS OPEN/CLOSED (OF) TRIP INDICATION (SD) FORM C CONTACTS RATING: 6 AMPS AT 24 VAC, 48 VAC, 110 VAC 6 AMPS AT 24 VDC, 2.5 AMPS AT 48 VDC, 0.6 AMPS AT 110 VDC MAXIMUM OF 4 CONTACTS PER CIRCUIT BREAKER

FRAME	LUG	COPPER CONDUCTOR RANGE AWG	STRIP LENGTH
H-FRAME THERMAL-MAGNETIC 15-150 AMP	AL 150 HD	(1) #14-3/0 #14-#10 50 LB-IN #8-3/0 120 LB-IN	0.65 INCH
J-FRAME THERMAL-MAGNETIC 175 AMP	AL 175 JD	(1) 4-4/0 225 LB-IN	1.00 INCH
J-FRAME THERMAL-MAGNETIC 200-250 AMP	AL 250 JD	(1) 3/0-350 KCMIL 225 LB-IN	1.00 INCH
J-FRAME ELECTRONIC TRIP ADJUSTABLE RANGE 70-250 100% RATED ASSEMBLY	CU 250 JD	(1) 1/0-300 KCMIL 250 LB-IN	1.00 INCH

-THIS IS A CONTROLLED ITEM-
PER CPG PROCEDURE FPC-1002
TO MAINTAIN COMPLIANCE WITH REQUIREMENTS OF THE CODES, STANDARDS, OR AGENCIES LISTED BELOW
 CSA IEC CE OTHER NEMA ABYC
 IEC OTHER OTHER
CHANGES, DEVIATIONS, OR SUBSTITUTIONS OF MATERIAL, PROCESS, OR PERFORMANCE FOR THIS ITEM MUST BE APPROVED BY THE FOLLOWING CONTROLLED ITEM APPROVER
RESPONSIBLE CIA ROLE: STATIONARY GENSET CIA
RESPONSIBLE CIA ROLE: SEISMIC

UNLESS OTHERWISE SPECIFIED, ALL DIMENSIONS ARE IN MILLIMETERS		SIM TO: NONE	OWN: R.WEHNBERG		CUMMINS POWER GENERATION	
DO NOT SCALE PRINT		DO NOT SCALE PRINT	CAD: P.LARSON		OUTLINE, CIRCUIT BREAKER	
DIM X ± 1 .X ± 0.8 .XX ± 0.38 ANG TOL: ± 1.0°	TOLERANCE 0.00- 4.99 +0.15/-0.08 5.00- 9.99 +0.20/-0.10 10.00-17.49 +0.25/-0.13 17.50-24.99 +0.30/-0.13	DATE: 19NOV12 FIRST USED ON: ARROW SITE CODE: PGF	APVD: P.LARSON DATE: 19NOV12 SITE CODE: PGF	SHEET: 1 OF 1 REV: B	PART NO: A044P050	SHEET: 1 OF 1 REV: B

2 POLE & 3 POLE J-FRAME

3 POLE H-FRAME

2 POLE H-FRAME

REL NO	LTR	NO	REVISION	DWN	CKD	APVD	DATE
ECO-176287	D	1	PART A050J727: "UPDATE MEP"	KSP	KAM	WINGFIELD	03APR18
		2	ZONE A3; RMV C11 LABEL	KSP	KAM	WINGFIELD	03APR18

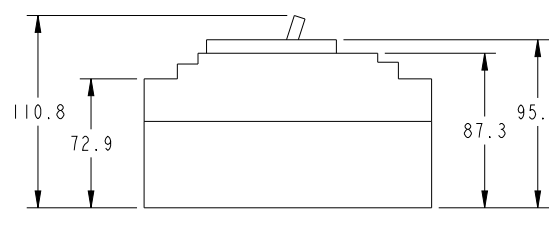
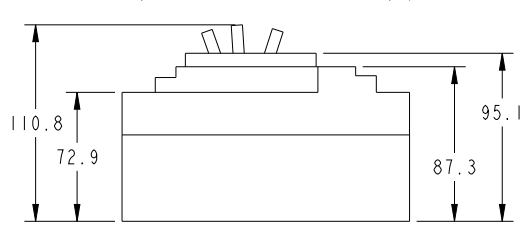
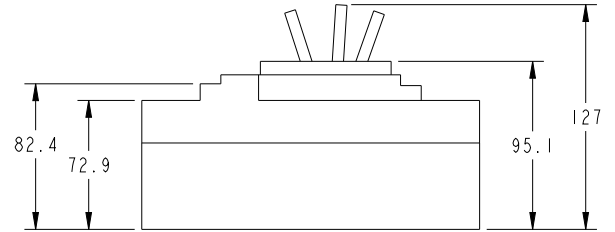
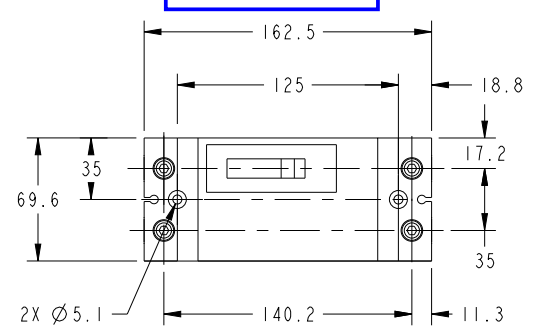
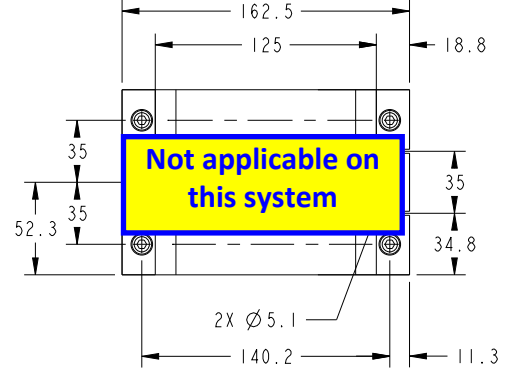
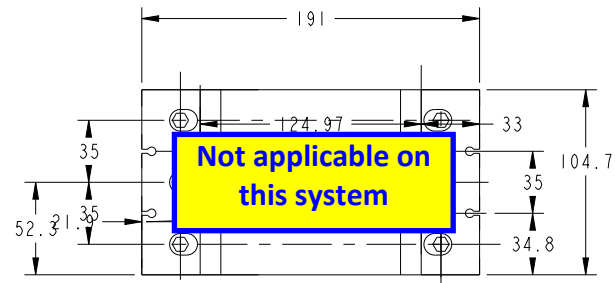

- NOTES:
- THIS PART IS MANUFACTURER SOURCE CONTROLLED.
 - SUPPLIED WITH LINE & LOAD MECHANICAL LUGS :
2.1 FOR THERMAL-MAGNETIC TRIP : AL/CU.
2.2 FOR ELECTRONIC TRIP: CU FOR 90°C.
 - | INTERRUPTING RATINGS | KA |
|----------------------|-----------------------|
| UL / CSA / NOM | 240 Vac 25 |
| | 480 Vac 18 |
| | 600 Vac 14 |
| IEC 947-2 | 220/240 Vac 25/25 |
| Icu/Ics | 380/440/415 Vac 18/18 |
| | 500/525 Vac 14/14 |
 - H-FRAME: .65" WIRE STRIP LENGTH,
LUG TORQUE= A : #14-#10 AWG 50 LB-IN,75°C.
B : #8-3/0 AWG 120 LB-IN,75°C.
 - J-FRAME: 1" WIRE STRIP LENGTH,
LUG TORQUE= 1/0 AWG- 300 kcmil 250 LB-IN,75°C.

TABULATION

PART NUMBER	CURRENT ER	AMP_RATING	VOLTS (UL/IEC)	FRAME_TYPE	POLES	BREAKER_TYPE	TRIP
A043E193	ECO-126169	250A	600	J-FRAME	2	JD	THERMAL-MAGNETIC 50-60 Hz
A043E195	ECO-126169	225A	600	J-FRAME	2	JD	
A043E199	ECO-126169	200A	600	J-FRAME	2	JD	
A043E202	ECO-126169	175A	600	J-FRAME	2	JD	
A043L510	ECO-126169	250A	600	J-FRAME	3	JD	
A043L517	ECO-126169	225A	600	J-FRAME	3	JD	
A043L520	ECO-126169	200A	600	J-FRAME	3	JD	
A043L619	ECO-126169	175A	600	J-FRAME	3	JD	
A043C676	ECO-126169	150A	600	H-FRAME	2	HD	
A043D274	ECO-126169	125A	600	H-FRAME	2	HD	
A043D324	ECO-126169	100A	600	H-FRAME	2	HD	
A043D326	ECO-126169	90A	600	H-FRAME	2	HD	
A043D328	ECO-126169	80A	600	H-FRAME	2	HD	
A043E169	ECO-126169	70A	600	H-FRAME	2	HD	
A043E179	ECO-126169	60A	600	H-FRAME	2	HD	
A043E181	ECO-126169	50A	600	H-FRAME	2	HD	
A043E183	ECO-126169	40A	600	H-FRAME	2	HD	
A043E185	ECO-126169	30A	600	H-FRAME	2	HD	
A043E187	ECO-126169	20A	600	H-FRAME	2	HD	
A043E189	ECO-126169	15A	600	H-FRAME	2	HD	
A043E191	ECO-126169	25A	600	H-FRAME	2	HD	
A043K991	ECO-126169	150A	600	H-FRAME	3	HD	
A043K994	ECO-126169	125A	600	H-FRAME	3	HD	
A043K997	ECO-126169	90A	600	H-FRAME	3	HD	
A043L012	ECO-126169	80A	600	H-FRAME	3	HD	
A043L024	ECO-126169	100A	600	H-FRAME	3	HD	
A043L451	ECO-126169	70A	600	H-FRAME	3	HD	
A043L459	ECO-126169	60A	600	H-FRAME	3	HD	
A043L461	ECO-126169	50A	600	H-FRAME	3	HD	
A043L464	ECO-126169	40A	600	H-FRAME	3	HD	
A043L475	ECO-126169	30A	600	H-FRAME	3	HD	
A043L480	ECO-126169	20A	600	H-FRAME	3	HD	
A043L506	ECO-126169	15A	600	H-FRAME	3	HD	
A043L508	ECO-126169	25A	600	H-FRAME	3	HD	
A044C640	ECO-126169	SET TRIP: 70 TO 250 A	600	J-FRAME	3	JD	ELECTRONIC 50-60 Hz
A047W923	ECO-137891	225A Cu LUG	600	J-FRAME	3	JD	THERMAL-MAGNETIC 50-60 Hz
A050J725	ECO-145094	250A	600	J-FRAME	3	JD	LSI ELECTRONIC TRIP 80%
A050J727	ECO-145094	250A	600	J-FRAME	3	JD	LSI ELECTRONIC TRIP 100%

UNLESS OTHERWISE SPECIFIED, ALL DIMENSIONS ARE IN MILLIMETERS		SH TO: NONE	DWN: S_GAMBHIRE		CUMMINS POWER GENERATION	
DO NOT SCALE PRINT		CKD: M_TULADHAR	APVD: M_POZO		BREAKER, CIRCUIT	
DIM	X ± 1 .X ± 0.8 .XX ± 0.38	TOLER	DATE: 24SEP12	SITE CODE	PGF	SHEET: 1 OF 1
ANG TOL: ± 1.0°	SCALE: 1/2	CONFIDENTIAL	ARROW	PGF	D	DATE: 24SEP12
PROPERTY OF CUMMINS POWER GENERATION GROUP			DATE: 24SEP12	PGF	D	DATE: 24SEP12

AC ACCESSORY LOAD TABLE

CUSTOMER AC CONNECTION TERMINALS

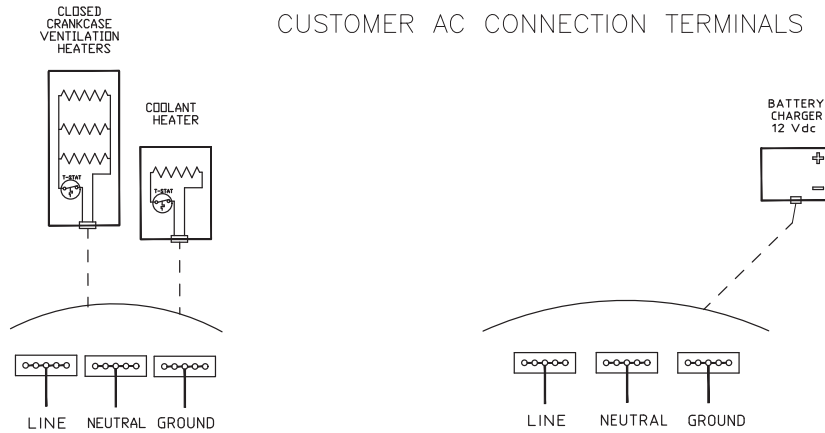

COOLANT HEATER 1000 WATTS, 120 VAC, 8.33 AMPS
 CCV HEATERS 120 WATTS, 120VAC, 1.0 AMP
 BATTERY CHARGER 192 WATTS, 120 VAC, 1.67 AMPS

NOTES:

1. INSTALLER TO PROVIDE BRANCH CIRCUITS TO POWER ALL ACCESSORIES
2. ALL ACCESSORIES ARE SINGLE PHASE 120/240 Vac 60 Hz
3. FOLLOW REGIONAL REGULATIONS AND APPLICABLE ELECTRIC CODES FOR INSTALLATION
4. CCV HEATERS MUST BE CONNECTED TO A CONTINUOUSLY ENERGIZED CIRCUIT FROM BOTH UTILITY AND GENERATOR

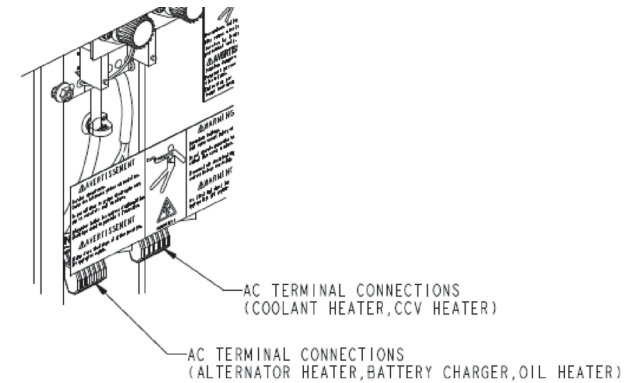

UNLESS OTHERWISE SPECIFIED,
ALL DIMENSIONS ARE IN INCHES

PREP. BY: JPK 12/3/2024

REL NO	LTR	NO	REVISION	DWN	CKD	APVD	DATE
ECO-166360	G	1	ZONE A3, RMV C11 LABEL	MN	JP	J.BUTLER	25NOV16
		2	SEE SHEET 6	MN	JP	J.BUTLER	25NOV16

SEISMIC INSTALLATIONS NOTES:

1. THE DESIGN OF POST-INSTALLED ANCHORS IN CONCRETE USED FOR THE COMPONENT ANCHORAGE IS PRE-QUALIFIED FOR SEISMIC APPLICATIONS IN ACCORDANCE WITH "ACI 355.2-07" AND DOCUMENTED IN A REPORT BY A REPUTABLE TESTING AGENCY. (EX. THE EVALUATION SERVICE REPORT ISSUED BY THE INTERNATIONAL CODE COUNCIL)
2. ANCHORS MUST BE INSTALLED TO AN EMBEDMENT DEPTH AS RECOMMENDED IN THE PRE-QUALIFICATION TEST REPORT AS DEFINED IN NOTE 1. FOR "CBC 2013" APPLICATIONS.
3. ANCHORS MUST BE INSTALLED IN MINIMUM 3000 PSI COMPRESSIVE STRENGTH NORMAL WEIGHT STRUCTURAL CONCRETE. CONCRETE AGGREGATE MUST COMPLY WITH "ASTM C33".
4. ANCHORS MUST BE INSTALLED TO THE TORQUE SPECIFICATION AS RECOMMENDED BY THE ANCHOR MANUFACTURER.
5. ANCHORS MUST BE INSTALLED IN LOCATIONS SPECIFIED ON THIS INSTALLATION DRAWING.
6. WASHERS MUST BE INSTALLED AT EACH ANCHOR LOCATION BETWEEN THE ANCHOR HEAD AND EQUIPMENT FOR TENSION LOAD DISTRIBUTION. WASHERS MUST BE TYPE A OR B PLAIN WASHERS MEETING ASME B18.21.1-2009. WASHER SIZE TO MATCH ANCHOR DIAMETER.
7. CONCRETE FLOOR SLAB AND CONCRETE HOUSEKEEPING PADS MUST BE DESIGNED AND REBAR REINFORCED FOR SEISMIC APPLICATIONS IN ACCORDANCE WITH "ACI 318-11".
8. ALL HOUSEKEEPING PAD THICKNESSES MUST BE DESIGNED IN ACCORDANCE WITH THE PRE-QUALIFICATION TEST REPORT AS DEFINED IN NOTE 1 OR A MINIMUM OF 1.5X THE ANCHOR EMBEDMENT DEPTH, WHICHEVER IS LARGEST (UNLESS NOTED OTHERWISE).
9. ALL HOUSEKEEPING PADS MUST BE DOWELLED OR CAST INTO THE BUILDING STRUCTURAL FLOOR SLAB AND DESIGNED FOR SEISMIC APPLICATION PER "ACI 318-11" AND AS APPROVED BY THE STRUCTURAL ENGINEER OF RECORD.
10. (NOTE REMOVED)
11. FLOOR MOUNTED EQUIPMENT (WITH OR WITHOUT A HOUSEKEEPING PAD) MUST BE INSTALLED TO A STEEL REINFORCED STRUCTURAL CONCRETE FLOOR THAT IS SEISMICALLY DESIGNED AND APPROVED BY THE ENGINEER OF RECORD TO RESIST ALL LOADS FROM EQUIPMENT BEING ANCHORED TO THE FLOOR.
12. COORDINATE REINFORCEMENT OF SUPPORT STRUCTURE WITH EQUIPMENT ANCHOR LOCATIONS.
13. ATTACHING SEISMIC CERTIFIED EQUIPMENT TO FLOOR OTHER THAN THOSE DESIGNED TO ACCEPT THE SEISMIC LOADS FROM CERTIFIED EQUIPMENT BY THE STRUCTURAL ENGINEER OF RECORD IS PROHIBITED.
14. (NOTE REMOVED)
15. (NOTE REMOVED)
16. INSTALLATION ONTO A STEEL ROOF STRUCTURE OR MANUFACTURED STEEL CURB SHALL BE COORDINATED WITH THE STRUCTURAL ENGINEER OF RECORD.
17. (NOTE REMOVED)
18. CONNECTIONS TO THE EQUIPMENT, INCLUDING BUT NOT LIMITED TO CONDUIT, WIRING FROM CABLE TRAYS, OTHER ELECTRICAL SERVICES OR OTHER CONNECTIONS, ARE THE RESPONSIBILITY OF THE INSTALLING CONTRACTOR AND BEYOND THE SCOPE OF THIS DOCUMENT. FLEXIBLE ATTACHMENTS MUST BE USED FOR SEISMIC CONNECTIONS TO ISOLATED COMPONENTS OR ISOLATED EQUIPMENT. THE FLEXIBLE ATTACHMENT MUST PROVIDE FOR ENOUGH RELATIVE DISPLACEMENT TO REMAIN CONNECTED TO THE EQUIPMENT AND FUNCTIONAL DURING AND AFTER A SEISMIC EVENT.

UNLESS OTHERWISE SPECIFIED, ALL DIMENSIONS ARE IN MILLIMETERS		SIM TO NONE	DWN T_ABEL		CUMMINS POWER GENERATION	
DO NOT SCALE PRINT		CKD T_SORENSEN	INSTALLATION, GENSET			
DATE 18 JAN 13		APVD D_GILLET	SEISMIC REQUIREMENTS		SHEET 1 of 7	
ANG TOL: ± 1.0°		SCALE: 1/1	PGF	DWG SIZE D	A044H911	
- CONFIDENTIAL - PROPERTY OF CUMMINS POWER GENERATION GROUP		FOR INTERPRETATION OF DIMENSIONING AND TOLERANCING, SEE ASME Y14.5M-1994	FIRST USED ON ALL		DWG REV C	

REL NO	LTR	NO	REVISION	DWN	CKD	APVD	DATE
ECO-166360	G	--	--	MN	JP	J. BUTLER	25NOV16

MOUNTING HOLE LOCATIONS

GRADE MOUNTING TO CONCRETE: 5/8" DIAMETER ANCHOR BOLTS,
4 LOCATIONS. SEE SHEET 7
GRADE OR ROOF MOUNTING TO STEEL: 5/8" DIAMETER THROUGH BOLTS,
4 LOCATIONS. SEE SHEET 7

EQUIPMENT SKID

CONTROL END

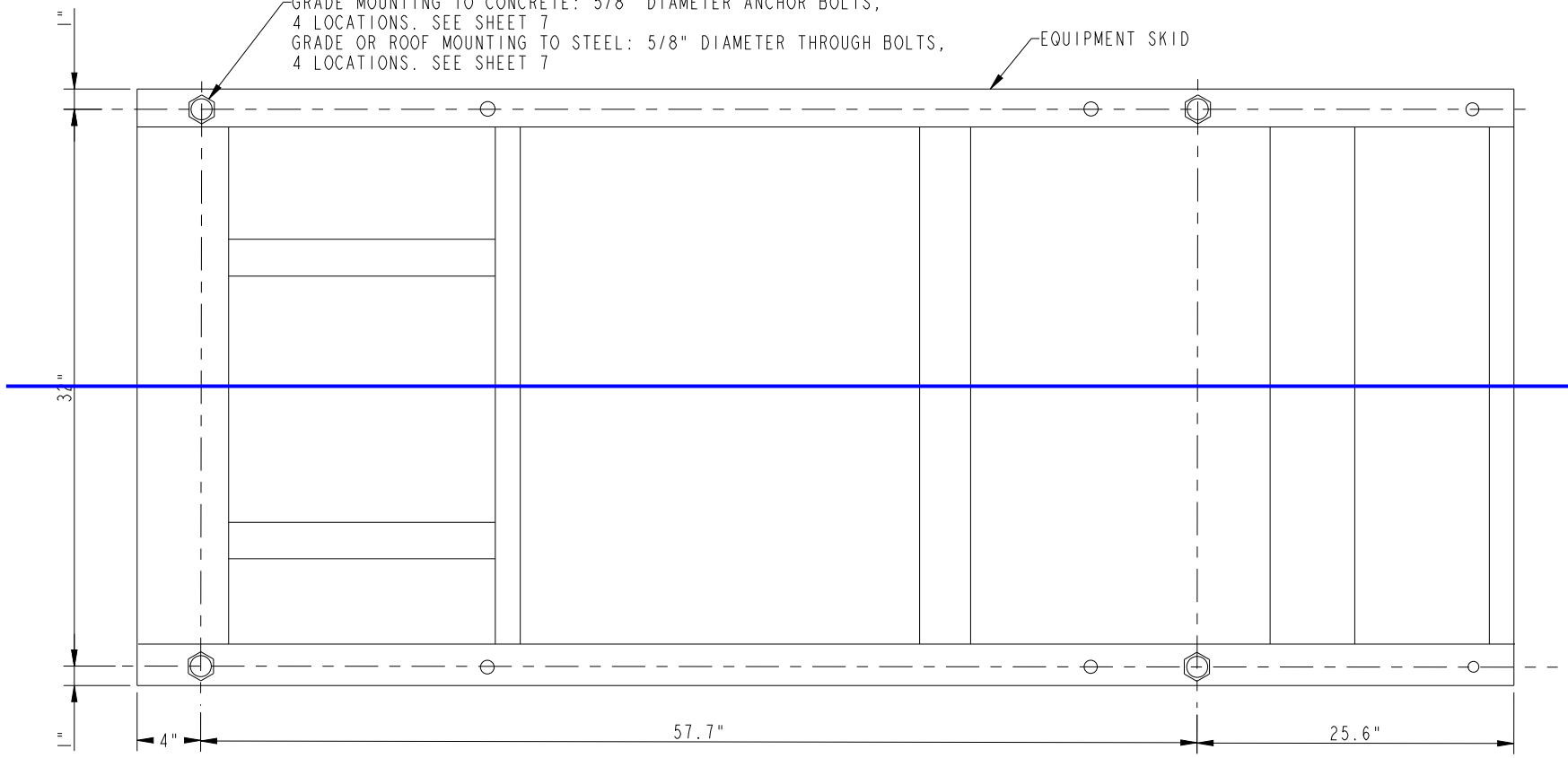

C30 N6, C36 N6, C40 N6, C36 N6H, C40 N6H, C45 N6H, C50 N6H, C60 N6H

MOUNTING HOLE LOCATIONS

GRADE MOUNTING TO CONCRETE: 5/8" DIAMETER ANCHOR BOLTS,
4 LOCATIONS. SEE SHEET 7
GRADE OR ROOF MOUNTING TO STEEL: 5/8" DIAMETER THROUGH BOLTS,
4 LOCATIONS. SEE SHEET 7

EQUIPMENT SKID

CONTROL END

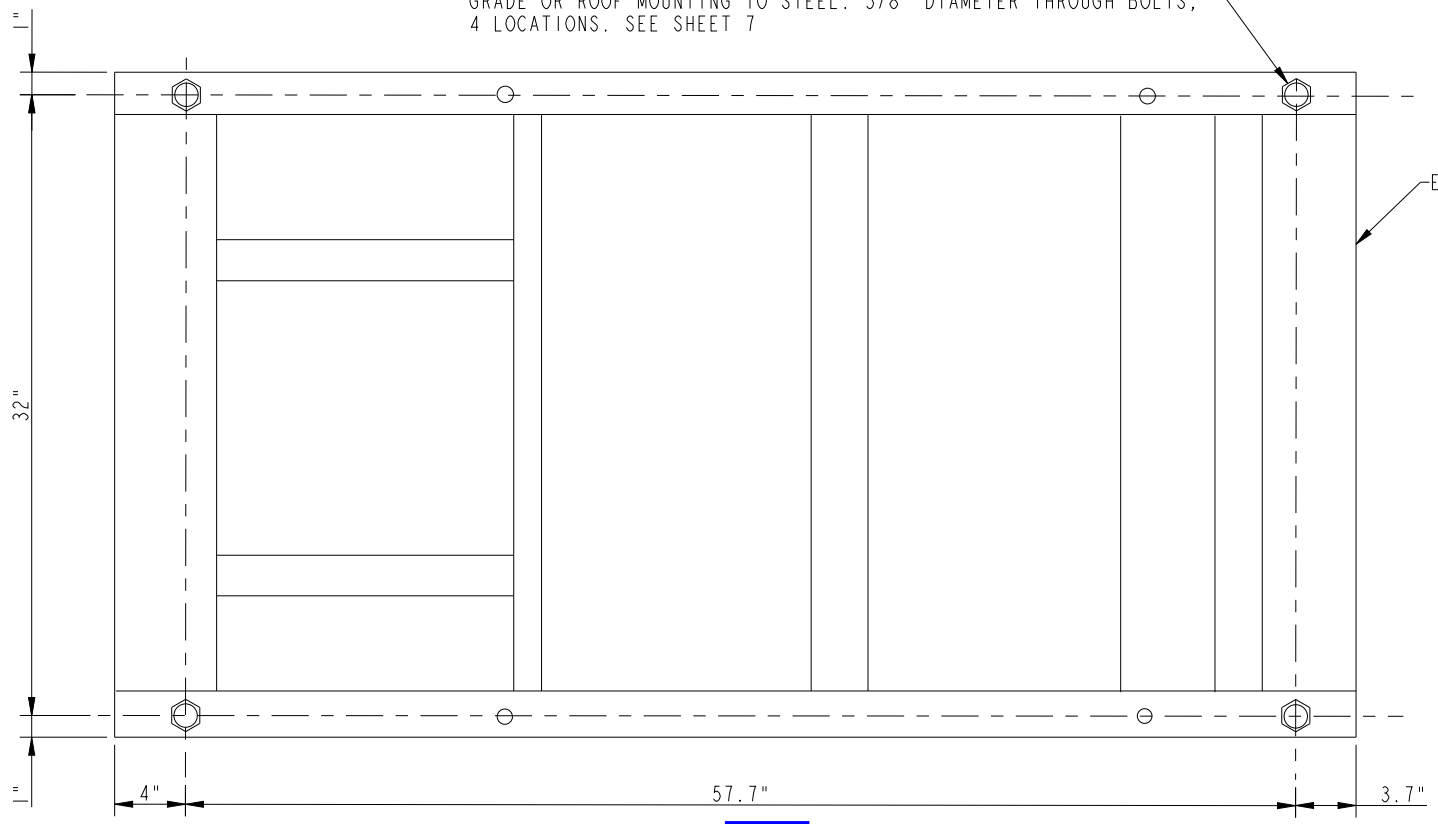

C20 N6, C22 N6, C25 N6, C30 N6H

UNLESS OTHERWISE SPECIFIED, ALL DIMENSIONS ARE IN MILLIMETERS		SIM TO NONE	DWN T_ABEL		CUMMINS POWER GENERATION	
DO NOT SCALE PRINT		CKD T_SORENSEN	INSTALLATION, GENSET		SEISMIC REQUIREMENTS	
DATE 18 JAN 13		APVD D_GILLET	SITE CODE		PGF	
ANG TOL: ± 1.0°		SCALE: 1/1	FOR INTERPRETATION OF DIMENSIONING AND TOLERANCING, SEE ASME Y14.5M-1994		FIRST USED ON ALL	
- CONFIDENTIAL - PROPERTY OF CUMMINS POWER GENERATION GROUP		PGF		D A044H911		SHEET 4 of 7

REL NO	LTR	NO	REVISION	DWN	CKD	APVD	DATE
ECO-166360	G	--	--	MN	JP	J.BUTLER	25NOV16

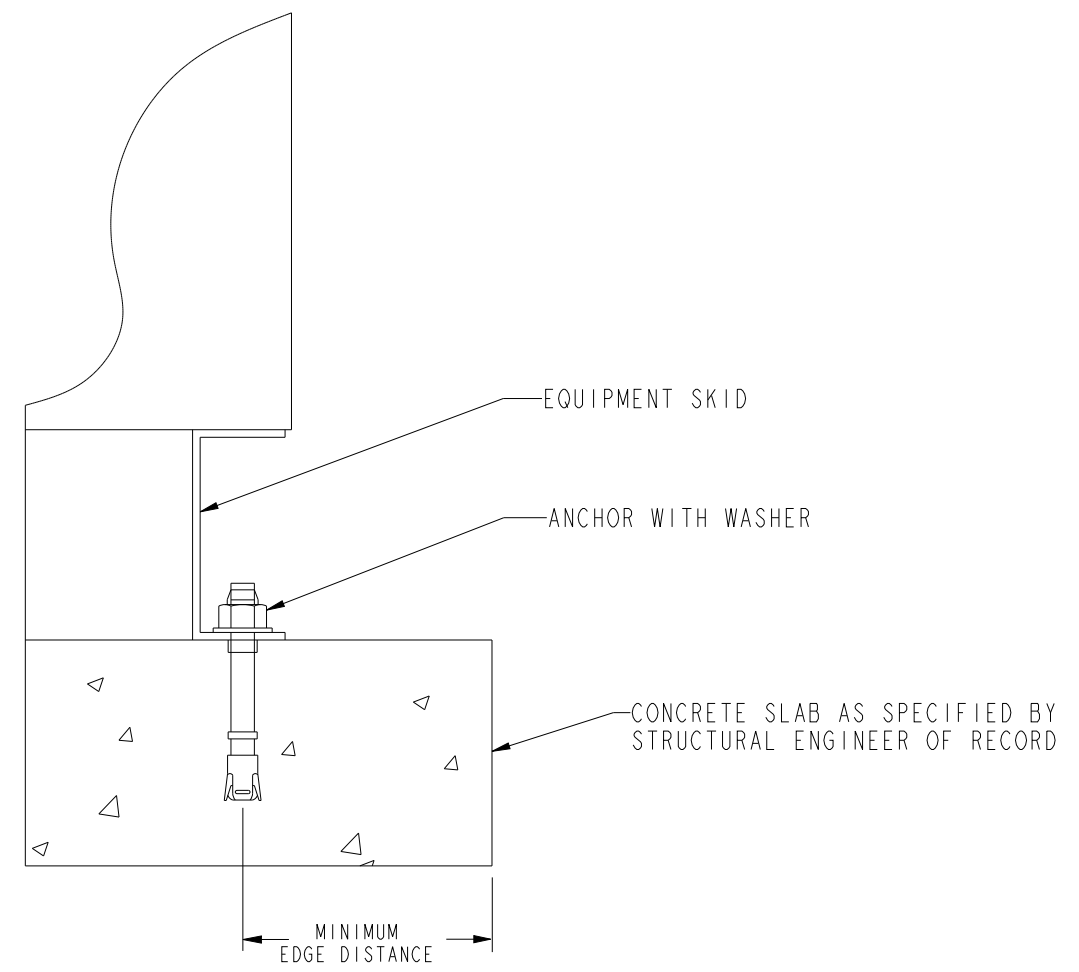

REFER TO APPLICABLE TABLE FOR ANCHOR SPECIFICATION AND LOCATION

CONCRETE CONNECTION

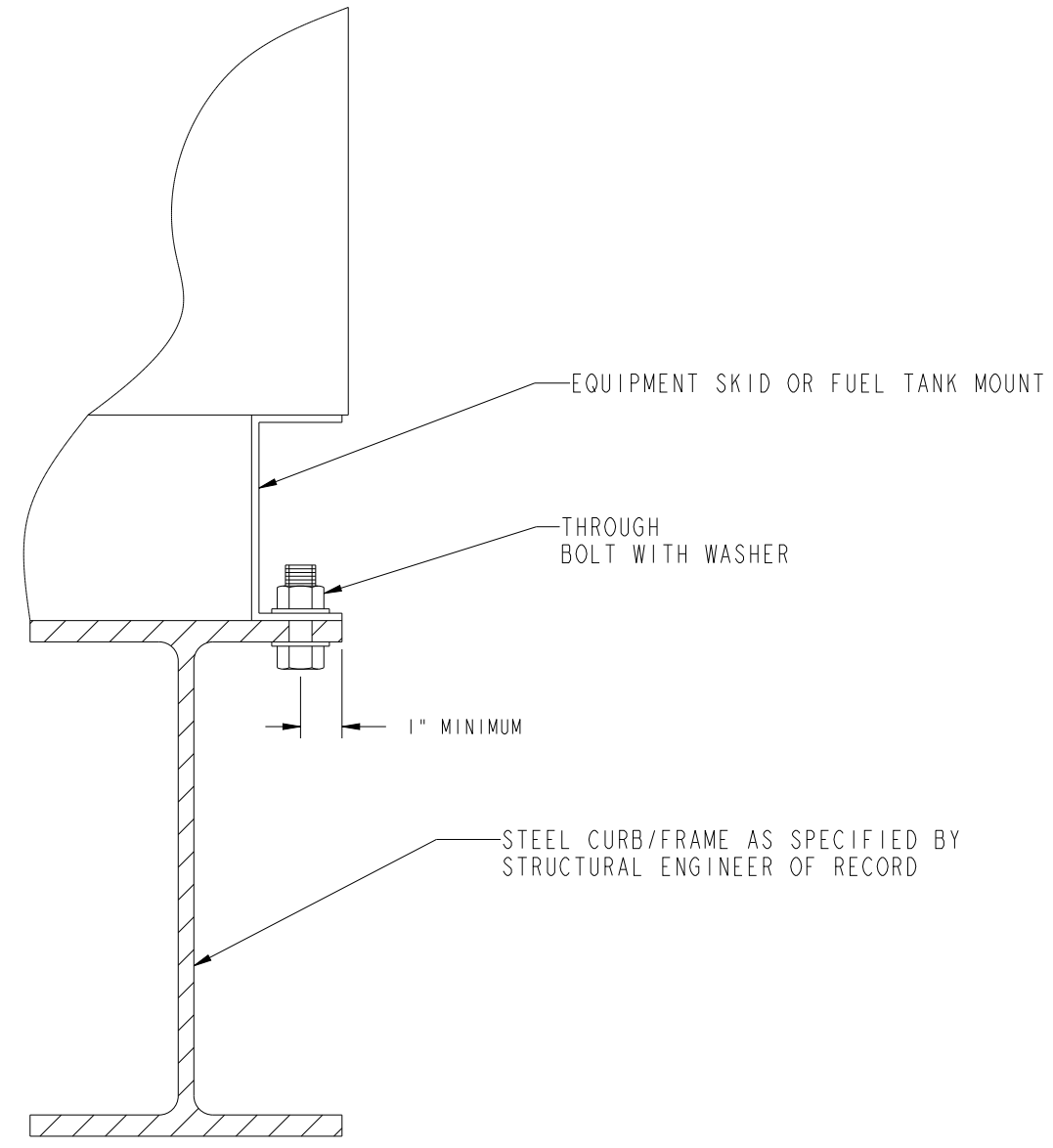

STEEL CONNECTION

UNLESS OTHERWISE SPECIFIED, ALL DIMENSIONS ARE IN MILLIMETERS		SIM TO NONE	DWN TABEL		CUMMINS POWER GENERATION	
DO NOT SCALE PRINT		CKD T_SORENSEN	APVD D_GILLETT		INSTALLATION, GENSET SEISMIC REQUIREMENTS	
DIM	TOLERANCE	HOLE	DATE 18JAN13	SITE CODE	DWG SIZE D	A044H911
X ± 1	0.00- 4.99 +0.15/-0.08			PGF		
.X ± 0.8	5.00- 9.99 +0.20/-0.10					
.XX ± 0.38	10.00-17.49 +0.25/-0.13					
	17.50-24.99 +0.30/-0.13					
ANG TOL: ± 1.0°	SCALE: 1/1	- CONFIDENTIAL - PROPERTY OF CUMMINS POWER GENERATION GROUP		FOR INTERPRETATION OF DIMENSIONING AND TOLERANCING, SEE ASME Y14.5M-1994	FIRST USED ON ALL	SHEET 7 of 7 DWG REV C G

SECTION 5

Warranty





Warranty Statement

Global Commercial Warranty Statement

Generator Set

Limited Warranty

Commercial Generating Set

This limited warranty applies to all Cummins Power Generation® branded commercial generating sets and associated accessories (hereinafter referred to as "Product").

This warranty covers any failures of the Product, under normal use and service, which result from a defect in material or factory workmanship.

Warranty Period:

The warranty start date[†] is the date of initial start up, first rental, demonstration or 18 months after factory ship date, whichever is sooner. See table for details.

Continuous Power (COP) is defined as being the maximum power which the generating set is capable of delivering continuously whilst supplying a constant electrical load when operated for an unlimited number of hours per year. No overload capability is available for this rating.

Prime Power (PRP) is defined as being the maximum power which a generating set is capable of delivering continuously whilst supplying a variable electrical load when operated for an unlimited number of hours per year. The permissible average power output over 24 hours of operation shall not exceed 70% of the PRP. For applications requiring permissible average output higher than stated, a COP rating should be used.

Limited-Time Running Power (LTP) is defined as the maximum power available, under the agreed operating conditions, for which the generating set is capable of delivering for up to 500 hours of operation per year.

Emergency Standby Power (ESP) is defined as the maximum power available during a variable electrical power sequence, under the stated operating conditions, for which a generating set is capable of delivering in the event of a utility power outage or under test conditions for up to 500 hours of operation per year. The permissible average power output over 24 hours of operation shall not exceed 70% of the ESP.

Environmental Protection Agency – Stationary Emergency (EPA-SE) is defined as being the maximum power available during a variable electrical power sequence, under the stated operating conditions, for which a generator set is capable of delivering in the event of a utility power outage or under test conditions and used in strict accordance with the EPA NSPS for stationary engines, 40 CFR part 60, subparts IIII and JJJJ, where a reliable utility must be present. The permissible average power output over 24 hours of operation shall not exceed 70% of the EPA-SE.

Data Center Continuous (DCC) is defined as the maximum power which the generator is capable of delivering continuously to a constant or varying electrical load for unlimited hours in a data center application.

**Base Warranty Coverage Duration
(Whichever occurs first)**

Rating	Months	Max. Hours
COP	12	Unlimited
PRP	12	Unlimited
LTP	12	500 hrs
ESP	24	1000 hrs
EPA-SE	24	Unlimited
DCC	24	Unlimited

[†] Warranty start date for designated rental and oil and gas model Products is determined to be date of receipt of Product by the end customer.

Cummins Power Generation® Responsibilities:

In the event of a failure of the Product during the warranty period due to defects in material or workmanship, Cummins Power Generation® will only be responsible for the following costs:

- All parts and labor required to repair the Product.
- Reasonable travel expenses to and from the Product site location.
- Maintenance items that are contaminated or damaged by a warrantable failure.

Owner Responsibilities:

The owner will be responsible for the following:

- Notifying Cummins Power Generation® distributor or dealer within 30 days of the discovery of failure.
- Installing, operating, commissioning and maintaining the Product in accordance with Cummins Power Generation®'s published policies and guidelines.
- Providing evidence for date of commissioning.
- Providing sufficient access to and reasonable ability to remove the Product from the installation in the event of a warrantable failure.
- Incremental costs and expenses associated with Product removal and reinstallation resulting from non-standard installations.
- Costs associated with rental of generating sets used to replace the Product being repaired.
- Costs associated with labor overtime and premium shipping requested by the owner.
- All downtime expenses, fines, all applicable taxes, and other losses resulting from a warrantable failure.

Limitations:

This limited warranty does not cover Product failures resulting from:

- Inappropriate use relative to designated power rating.
- Inappropriate use relative to application guidelines.
- Inappropriate use of an EPA-SE application generator set relative to EPA's standards.
- Normal wear and tear.
- Improper and/or unauthorized installation.
- Negligence, accidents or misuse.
- Lack of maintenance or unauthorized repair.
- Noncompliance with any Cummins Power Generation® published guideline or policy.
- Use of improper or contaminated fuels, coolants or lubricants.
- Improper storage before and after commissioning.
- Owner's delay in making Product available after notification of potential Product problem.
- Replacement parts and accessories not authorized by Cummins Power Generation®.
- Use of Battle Short Mode.
- Owner or operator abuse or neglect such as: operation without adequate coolant or lubricants; overfueling; overspeeding; lack of maintenance to lubricating, cooling or air intake systems; late servicing and maintenance; improper storage, starting, warm-up, run-in or shutdown practices, or for progressive damage resulting from a defective shutdown or warning device.

- Damage to parts, fixtures, housings, attachments and accessory items that are not part of the generating set.

This limited warranty does not cover costs resulting from:

- Difficulty in gaining access to the Product.
- Damage to customer property.

A "Data center" is defined as a dedicated facility that house computers and associated equipment for data storage and data handling.

Reliable utility is defined as utility power without routine or regularly scheduled black-outs.

Please contact your local Cummins Power Generation® Distributor for clarification concerning these limitations.

CUMMINS POWER GENERATION® RIGHT TO FAILED COMPONENTS:

Failed components claimed under warranty remain the property of Cummins Power Generation®. Cummins Power Generation® has the right to reclaim any failed component that has been replaced under warranty.

Extended Warranty:

Cummins Power Generation® offers several levels of Extended Warranty Coverage. Please contact your local Cummins Power Generation® Distributor for details.

www.power.cummins.com

THE WARRANTIES SET FORTH HEREIN ARE THE SOLE WARRANTIES MADE BY CUMMINS POWER GENERATION® IN REGARD TO THE PRODUCT. CUMMINS POWER GENERATION® MAKES NO OTHER WARRANTIES, EXPRESS OR IMPLIED, OR OF MERCHANTABILITY OR FITNESS FOR A PARTICULAR PURPOSE.

IN NO EVENT IS CUMMINS POWER GENERATION® LIABLE FOR INCIDENTAL OR CONSEQUENTIAL DAMAGES.

This limited warranty shall be enforced to the maximum extent permitted by applicable law. This limited warranty gives the owner specific rights that may vary from state to state or from jurisdiction to jurisdiction.

Product Model Number: _____
 Product Serial Number: _____
 Date in Service: _____

power.cummins.com

Copyright © 2017 Cummins Inc. All rights reserved.

Cummins, the “C” logo, PowerCommand, AmpSentry, and InPower are trademarks of Cummins Inc.

Other company, product, or service names may be trademarks or service marks of others.

Specifications are subject to change without notice.

