



Operator Manual

CENTUM™ Series Generator Sets

**QSK78 Engine with PowerCommand® 3.3 Control and
S9 Alternator**

C2750D6E (Spec A)

C3000D6EB (Spec A)

**CALIFORNIA
Proposition 65**

Warning: Natural Gas/Liquid Propane Gas engine exhaust and some of its constituents are known to the State of California to cause cancer, birth defects, and other reproductive harm.

Table of Contents

1. IMPORTANT SAFETY INSTRUCTIONS	1
1.1 Warning, Caution, and Note Styles Used in This Manual	1
1.2 General Information	1
1.2.1 General Safety Precautions	2
1.3 Generator Set Safety Code	5
1.3.1 Moving Parts Can Cause Severe Personal Injury or Death	5
1.3.2 Moving the Generator Set.....	5
1.3.3 Generator Set Operating Areas	7
1.4 Electrical Shocks and Arc Flashes Can Cause Severe Personal Injury or Death.....	8
1.4.1 AC Supply and Isolation.....	8
1.4.2 Medium Voltage Equipment (601 V to 15 kV - U.S. and Canada)	8
1.5 Fuel and Fumes Are Flammable	8
1.5.1 Gaseous Fuels.....	9
1.5.2 Spillage	9
1.5.3 Fluid Containment.....	9
1.5.4 Do Not Operate in Flammable and Explosive Environments	9
1.6 Aftertreatment Systems	9
1.6.1 Selective Catalytic Reduction (SCR)	10
1.6.2 Diesel Exhaust Fluid (DEF).....	10
1.7 Exhaust Gases Are Deadly.....	10
1.7.1 Exhaust Precautions	10
1.8 Earth Ground Connection	11
1.9 Distribution Panel Door	12
1.10 Transport and Towing.....	12
1.11 Beware of Traffic Hazards	13
1.12 Tipping Hazard.....	13
1.13 Decommissioning and Disassembly	13
2. INTRODUCTION.....	15
2.1 About This Manual.....	15
2.2 Schedule of Abbreviations	15
2.3 Related Literature	17
2.3.1 Further Information - Literature	18
2.4 After Sales Services.....	18
2.4.1 Maintenance.....	18
2.4.2 Warranty.....	18
2.4.3 How to Obtain Service	18
3. SYSTEM OVERVIEW	21
3.1 Generator Set Identification	21
3.1.1 Nameplate.....	21
3.2 Generator Set Components.....	21

3.3 Generator Set Performance Data	22
3.3.1 Acoustic Information 60 Hz (1800 RPM)	22
3.3.2 Generator Set Fuel Consumption	23
3.4 Engine	23
3.4.1 Fuel Changeover System	24
3.5 Cooling System Components	25
3.6 Sensors	25
3.7 Pyrometers - Engine Exhaust	25
3.8 Heaters	26
3.8.1 Heater Supply and Isolation	26
3.8.2 Coolant Heater	26
3.9 Air Cleaner	26
3.9.1 Normal Duty Air Cleaner	26
3.10 External Emergency Stop Switch	27
3.11 Seismic IBC Labelling	28
3.12 System Options	28
3.12.1 Battery Charger	28
3.12.2 Battery Charger – Set Mounted	28
3.12.3 Battery Charger - 20 Amp/24 Volt	29
3.12.4 PowerCommand Universal Annunciator	30
3.12.5 Mechanical Run-time Recorder	31
3.12.6 Oil Sampling Valve	32
3.12.7 Oil Maintainer System	32
3.12.8 Coolant Heater	33
3.12.9 Heater Distribution Panel	33
4. CONTROL SYSTEM - POWERCOMMAND 3.3	35
4.1 Control System Description	35
4.1.1 Control System Panel	36
4.1.2 Operating Modes	36
4.1.3 Power On and Sleep Modes	39
4.1.4 AmpSentry Maintenance Mode	39
4.2 Operator Panel	39
4.2.1 Selection Buttons	40
4.2.2 Default Settings	41
4.2.3 Lamp Indicators	41
4.2.4 Lamp (LED) Test Button	42
4.2.5 Reset Button	42
4.2.6 CB Open Button	42
4.2.7 CB Closed Button	42
4.2.8 Graphical Display and Buttons	42
4.3 Operator Panel - Initial Operator Menu	45
4.3.1 Initial Menu Data	45
4.4 Operator Panel - Generator Set Data Operator Menu	47
4.4.1 Generator Set Data	47
4.5 Operator Panel - Engine Data Operator Menu	49

4.5.1 Engine Data	49
4.5.2 History/About Menu.....	51
4.6 Operator Panel - Alternator Data Operator Menu.....	54
4.6.1 Alternator Data	54
4.7 Operator Panel - Faults and Warnings Menus	56
4.7.1 Fault Menu	56
4.7.2 Fault Messages.....	58
4.7.3 Fault Acknowledgement.....	58
4.7.4 Warning Fault Menu.....	58
4.7.5 Faults History Data Operator Menu	60
4.8 Operator Panel - Adjust Menu	62
4.9 Operator Panel - Genset Setup Data Operator Menu	64
4.10 Operator Panel - Paralleling Status Menu	65
4.11 Operator Panel - Paralleling/Basic Setup Menu	73
4.12 Selecting Operating Modes.....	77
4.12.1 Passwords and Mode Change Access	77
4.12.2 Selecting Manual Run Mode.....	78
4.12.3 Selecting Auto Mode.....	78
4.12.4 Selecting Off Mode	79
4.13 Changing the Display Language on the HMI.....	80
5. OPERATION - POWERCOMMAND 3.3	81
5.1 Safety	81
5.2 Introduction	81
5.3 Maintenance	82
5.4 Operating Recommendations	82
5.4.1 Running-in.....	82
5.4.2 No and Low Load Operation.....	82
5.4.3 Exercise Period.....	82
5.4.4 Low Operating Temperatures	82
5.4.5 High Operating Temperatures	83
5.4.6 Operating Conditions	83
5.4.7 Derating Factors	84
5.5 Generator Set Operation.....	85
5.5.1 Sequence of Operation.....	85
5.6 Before Starting.....	85
5.6.1 Operator's Pre-Start Checks.....	86
5.6.2 Starting at Operator Panel (Manual Run Mode)	88
5.6.3 Starting from Remote Location (Auto Mode)	88
5.6.4 Cold Starting with Loads.....	89
5.7 Stopping.....	90
5.7.1 Stopping at the Operator Panel (Manual Mode).....	90
5.7.2 Stopping from Operator Panel (Auto Mode)	90
5.7.3 Stopping from Remote Location (Auto Mode)	91
5.7.4 Code 1433 or 1434 - Emergency Stop	91
5.8 Frequency Changing.....	92

5.9 Paralleling Operation	92
5.9.1 Speed and Voltage Matching.....	92
5.9.2 Operation When in Parallel	93
5.9.3 Generator Set Application Type.....	93
5.9.4 Standalone Application	94
5.9.5 Synchronize Only	95
5.9.6 Isolated Bus Only	96
5.9.7 Power Transfer Control.....	97
5.9.8 Conditions for Each Paralleling State	102
6. MAINTENANCE	113
6.1 Locking the Generator Set Out of Service.....	114
6.1.1 Immobilizing for Safe Working	114
7. PERIODIC MAINTENANCE.....	117
7.1 Periodic Maintenance Schedule	117
7.1.1 Air Intake Maintenance Schedule	117
7.1.2 Control Maintenance Schedule.....	118
7.1.3 Cooling Maintenance Schedule	118
7.1.4 Engine Maintenance Schedule	119
7.1.5 Exhaust Maintenance Schedule	121
7.1.6 Generator Set Maintenance Schedule.....	121
7.1.7 Alternator Service Schedule	123
7.2 Generator Set Long Term Storage	125
7.2.1 Required Materials.....	125
7.2.2 Procedure.....	125
7.2.3 Additional Steps	128
7.2.4 Returning the Generator Set to Service.....	128
7.3 Maintenance Procedures - Daily or When Refueling.....	130
7.3.1 General Information	130
7.3.2 Engine Operation Report	130
7.4 Cooling System.....	131
7.4.1 Water Quality Check.....	131
7.4.2 Coolant Level Check - Introduction.....	131
7.4.3 Drive Belt - Inspection.....	134
7.4.4 Radiator Check	135
7.4.5 Cooling Fan - Inspection.....	135
7.5 Engine Oil	136
7.5.1 Level Check	136
7.5.2 Oil Fill	138
7.5.3 Oil Sampling	139
7.6 Fuel System.....	140
7.6.1 Fuel Level	141
7.6.2 Fuel/Water Separator - Spin on Type.....	141
7.7 Fuel Filter Maintenance	142
7.7.1 Fuel Filters - Drain	142
7.7.2 Fuel Filters - Element Removal	143

7.7.3 Fuel Filters - Element Removal	144
7.7.4 Fuel Filter - Element Replacement	146
7.8 Fluid Containment.....	146
7.9 Hoses and Fuel Lines - Check	148
7.10 Air Intake System.....	148
7.10.1 Air Cleaner Service Indicator	148
7.10.2 Normal Duty Air Cleaner	149
7.11 Exhaust System	151
7.12 Generator Set Output - AC Electric System	152
7.13 DC Electrical System	152
7.14 Batteries.....	153
7.14.1 Storage.....	153
7.14.2 Battery Type Specification	153
7.14.3 Safety Precautions.....	153
7.14.4 Battery Maintenance	155
7.14.5 Battery Fault Finding.....	158
8. TROUBLESHOOTING	159
8.1 Control System	159
8.2 Safety Considerations.....	159
8.3 Fault Finding	160
8.4 Status Indicators - PowerCommand 3.3.....	161
8.4.1 Not in Auto	161
8.4.2 Remote Start	161
8.4.3 Warning	162
8.4.4 Shutdown Status	162
8.4.5 Generator Set Running Lamp	162
8.5 Fault/Status Codes - PowerCommand 3.3	162
8.5.1 Fault Messages.....	162
8.5.2 Fault Acknowledgement.....	162
8.5.3 Fault Codes - PowerCommand 3.3	163
8.5.4 Troubleshooting Procedures for Fault Codes	207
8.6 Line Circuit Breaker	212
9. MANUFACTURING FACILITIES.....	213

This page is intentionally blank.

1 IMPORTANT SAFETY INSTRUCTIONS

SAVE THESE INSTRUCTIONS. This manual contains important instructions that should be followed during installation and maintenance of the generator set and batteries.

Safe and efficient operation can be achieved only if the equipment is properly operated and maintained. Many accidents are caused by failure to follow fundamental rules and precautions.

1.1 Warning, Caution, and Note Styles Used in This Manual

The following safety styles and symbols found throughout this manual indicate potentially hazardous conditions to the operator, service personnel, or equipment.

 DANGER
<i>Indicates a hazardous situation that, if not avoided, will result in death or serious injury.</i>

 WARNING
<i>Indicates a hazardous situation that, if not avoided, could result in death or serious injury.</i>

 CAUTION
<i>Indicates a hazardous situation that, if not avoided, could result in minor or moderate injury.</i>

NOTICE
Indicates information considered important, but not hazard-related (e.g., messages relating to property damage).

1.2 General Information

This manual should form part of the documentation package supplied by Cummins with specific generator sets. In the event that this manual has been supplied in isolation, contact your authorized distributor.

NOTICE
It is in the operator's interest to read and understand all warnings and cautions contained within the documentation relevant to the generator set, its operation and daily maintenance.

1.2.1 General Safety Precautions

WARNING

Hot Pressurized Liquid

Contact with hot liquid can cause severe burns.

Do not open the pressure cap while the engine is running. Let the engine cool down before removing the cap. Turn the cap slowly and do not open it fully until the pressure has been relieved.

WARNING

Moving Parts

Moving parts can cause severe personal injury.

Use extreme caution around moving parts. All guards must be properly fastened to prevent unintended contact.

WARNING

Toxic Hazard

Used engine oils have been identified by some state and federal agencies to cause cancer or reproductive toxicity.

Do not ingest, breathe the fumes, or contact used oil when checking or changing engine oil. Wear protective gloves and face guard.

WARNING

Electrical Generating Equipment

Incorrect operation can cause severe personal injury or death.

Do not operate equipment when fatigued, or after consuming any alcohol or drug.

WARNING

Toxic Gases

Substances in exhaust gases have been identified by some state and federal agencies to cause cancer or reproductive toxicity.

Do not breathe in or come into contact with exhaust gases.

WARNING

Combustible Liquid

Ignition of combustible liquids is a fire or explosion hazard which can cause severe burns or death.

Do not store fuel, cleaners, oil, etc., near the generator set.

WARNING

High Noise Level

Generator sets in operation emit noise, which can cause hearing damage.

Wear appropriate ear protection at all times.

⚠ WARNING**Hot Surfaces**

Contact with hot surfaces can cause severe burns.

The unit is to be installed so that the risk of hot surface contact by people is minimized. Wear appropriate PPE when working on hot equipment and avoid contact with hot surfaces.

⚠ WARNING**Electrical Generating Equipment**

Incorrect operation and maintenance can result in severe personal injury or death.

Make sure that only suitably trained and experienced service personnel perform electrical and/or mechanical service.

⚠ WARNING**Toxic Hazard**

Ethylene glycol, used as an engine coolant, is toxic to humans and animals.

Wear appropriate PPE. Clean up coolant spills and dispose of used coolant in accordance with local environmental regulations.

⚠ WARNING**Combustible Liquid**

Ignition of combustible liquids is a fire or explosion hazard which can cause severe burns or death.

Do not use combustible liquids like ether.

⚠ WARNING**Automated Machinery**

Accidental or remote starting of the generator set can cause severe personal injury or death.

Isolate all auxiliary supplies and use an insulated wrench to disconnect the starting battery cables (negative [-] first).

⚠ WARNING**Fire Hazard**

Materials drawn into the generator set are a fire hazard. Fire can cause severe burns or death.

Make sure the generator set is mounted in a manner to prevent combustible materials from accumulating under the unit.

⚠ WARNING**Fire Hazard**

Accumulated grease and oil are a fire hazard. Fire can cause severe burns or death.

Keep the generator set and the surrounding area clean and free from obstructions. Repair oil leaks promptly.

⚠ WARNING**Fall Hazard**

Falls can result in severe personal injury or death.

Make sure that suitable equipment for performing tasks at height are used in accordance with local guidelines and legislation.

⚠ WARNING**Fire Hazard**

Materials drawn into the generator set are a fire hazard. Fire can cause severe burns or death.

Keep the generator set and the surrounding area clean and free from obstructions.

⚠ WARNING**Pressurized System**

Pressurized systems can rupture/leak which can result in severe personal injury or death.

Use appropriate lock out/tag out safety procedures to isolate from all energy sources before performing any service tasks. Use PPE.

⚠ WARNING**Confined Areas**

Confined spaces or areas with restricted access or potential to entrap can cause severe personal injury or death.

Use appropriate lock out/tag out safety procedures to isolate from all energy sources. Use PPE. Follow site specific lone worker protocols/permits to work.

⚠ CAUTION**Manual Handling Heavy Objects**

Handling heavy objects can cause severe personal injury.

Use appropriate lifting equipment and perform tasks with two people where doing so would make completion of the task safe.

⚠ CAUTION**Power Tools and Hand Tools**

Tools can cause cuts, abrasions, bruising, puncture injuries.

Only trained and experienced personnel should use power tools and hand tools. Use PPE.

⚠ CAUTION**Sharp Edges and Sharp Points**

Projecting corners/parts may cause cuts, abrasions and other personal injury.

Use PPE. Be aware of sharp edges and corners/sharp points. Cover/protect them.

NOTICE

Keep multi-type ABC fire extinguishers close by. Class A fires involve ordinary combustible materials such as wood and cloth. Class B fires involve combustible and flammable liquid fuels and gaseous fuels. Class C fires involve live electrical equipment. (Refer to NFPA No. 10 in the applicable region.)

NOTICE

Before performing maintenance and service procedures on enclosed generator sets, make sure the service access doors are secured open.

NOTICE

Stepping on the generator set can cause parts to bend or break, leading to electrical shorts, or to fuel leaks, coolant leaks, or exhaust leaks. Do not step on the generator set when entering or leaving the generator set room.

1.3 Generator Set Safety Code

Before operating the generator set, read the manuals and become familiar with them and the equipment. Safe and efficient operation can be achieved only if the equipment is properly operated and maintained. Many accidents are caused by failure to follow fundamental rules and precautions.

⚠ WARNING***Electrical Generating Equipment***

Incorrect operation and maintenance can result in severe personal injury or death.

Read and follow all Safety Precautions, Warnings, and Cautions throughout this manual and the documentation supplied with the generator set.

1.3.1 Moving Parts Can Cause Severe Personal Injury or Death

- Keep hands, clothing, and jewelry away from moving parts. Do not wear loose clothing or jewelry in the vicinity of moving parts or while working on electrical equipment. Loose clothing and jewelry can become caught in moving parts.
- Before starting work on the generator set, disconnect the battery charger from its AC source, then disconnect the starting batteries using an insulated wrench, negative (–) cable first. This will prevent accidental starting.
- Make sure that fasteners on the generator set are secure. Tighten supports and clamps; keep guards in position over fans, drive belts, etc.
- If any adjustments must be made while the unit is running, use extreme caution around hot manifolds, moving parts, etc.

1.3.2 Moving the Generator Set

⚠ WARNING***Heavy Load***

Incorrect lifting or repositioning can cause severe personal injury or death.

Make sure that only suitably trained and experienced personnel transport and handle generator sets and associated components.

⚠ WARNING**Heavy Load**

Incorrect lifting or repositioning can cause severe personal injury or death.

Do not lift the generator set by attaching to the engine or alternator lifting points. Do not stand under or near the generator set when lifting.

⚠ WARNING**Mechanical Hazard**

Failed components may be ejected or operate incorrectly which can cause severe personal injury or death.

Do not climb the generator set; this may damage critical parts.

NOTICE

Make sure that any shipping brackets supplied with the generator set are fitted, before moving the generator set. Failure to install the shipping brackets before moving may result in damage to the generator set.

NOTICE

Access or service doors must be closed and locked before repositioning, and they must remain locked during transportation and siting.

It is essential that there are sufficient trained and experienced personnel in attendance to make sure the lifting and transportation of the generator set is undertaken in a safe and appropriate manner, and in accordance to local guidelines and legislation.

Before lifting the generator set, lifting points, angle of slings, mass, access to intended site, and the distance of movement should all be taken into account when organizing a suitable crane/hoist. Consult the generator set information supplied with the generator set for details of dimensions and mass.

- Make sure the fuel tank is empty.
- Make sure that the crane operating area is able to support the mass of the crane and the generator set.
- Make sure the equipment used for lifting is adequate to support the weight of the generator set.
- Attach the lifting device to the lifting points only using suitable shackles, chains, and spreader bars.
- Slowly tighten the slings. Inspect the lifting attachments before commencing a full lift to make sure they are attached correctly.
- Hoist the generator set slowly using the indicated lifting points only.
- Guide the generator set with ropes at a safe distance to prevent uncontrolled rotation when positioning the generator set.
- Move the generator set to the desired location and place in position, bringing the set down slowly.
- Loosen the slings; unhook and remove the shackles.

1.3.2.1 Positioning a Generator Set Using a Forklift Truck

WARNING

Heavy Load

Incorrect lifting or repositioning can cause severe personal injury or death.

Make sure that only suitably trained and experienced personnel transport and handle generator sets and associated components.

WARNING

Heavy Load

Incorrect lifting or repositioning can cause severe personal injury or death.

Do not attempt to lift a generator set with an undersized forklift truck.

NOTICE

Access or service doors must be closed and locked before repositioning, and they must remain locked during transportation and siting.

When using a forklift truck to transport/position the generator set, the dimensions, mass, and route must be taken into account when selecting an appropriate lifting truck.

It is essential that there are sufficient trained and experienced personnel in attendance to make sure the lifting and transportation of the generator set is undertaken in a safe and appropriate manner.

1. Insert the arms of the forklift into the forklift pockets. Make sure the generator set completely rests on the forklift arms.
2. Lift and handle the equipment slowly.
3. Lower the generator set in position.

1.3.3 Generator Set Operating Areas

WARNING

Ejected Debris

Debris ejected during destructive failure can cause serious injury or death by impact, severing or stabbing.

Do not to stand alongside the engine or alternator while the generator set is running.

- Operators must not stand alongside the engine or alternator while the generator set is running, unless the risks of doing so have been assessed and adequate mitigation steps have been taken.
- If there are operation/maintenance procedures that require spending time alongside the generator set when it is running, take every precaution to perform these tasks safely. Keep time spent performing these tasks to a minimum.
- Be aware of the product environment. Other equipment may be in operation or energized in the surrounding area.

1.4 Electrical Shocks and Arc Flashes Can Cause Severe Personal Injury or Death

- Only qualified service personnel certified and authorized to work on power circuits should work on exposed energized power circuits.
- All relevant service material must be available for any electrical work performed by certified service personnel.
- Exposure to energized power circuits with potentials of 50 VAC or 75 VDC or higher poses a significant risk of electrical shock and electrical arc flash.
- Refer to standard NFPA 70E, or equivalent safety standards in corresponding regions, for details of the dangers involved and for safety requirements.

1.4.1 AC Supply and Isolation

NOTICE

Local electrical codes and regulations (for example, *BS EN 12601:2010 Reciprocating internal combustion engine driven generating sets*) may require the installation of a disconnect means for the generator set, either on the generator set or where the generator set conductors enter a facility.

NOTICE

The AC supply must have the correct over current and earth fault protection according to local electrical codes and regulations. This equipment must be earthed (grounded).

It is the sole responsibility of the customer to provide AC power conductors for connection to load devices and the means to isolate the AC input to the terminal box; these must comply with local electrical codes and regulations. Refer to the wiring diagram supplied with the generator set.

The disconnecting device is not provided as part of the generator set, and Cummins accepts no responsibility for providing the means of isolation.

1.4.2 Medium Voltage Equipment (601 V to 15 kV - U.S. and Canada)

- Medium voltage acts differently than low voltage. Special equipment and training is required to work on or around medium voltage equipment. Operation and maintenance must be done only by persons trained and experienced to work on such devices. Improper use or procedures will result in severe personal injury or death.
- Do not work on energized equipment. Unauthorized personnel must not be permitted near energized equipment. Due to the nature of medium voltage electrical equipment, induced voltage remains even after the equipment is disconnected from the power source. Plan the time for maintenance with authorized personnel so that the equipment can be de-energized and safely grounded.

1.5 Fuel and Fumes Are Flammable

Fire, explosion, and personal injury or death can result from improper practices.

- Do not fill fuel tanks while the engine is running unless the tanks are outside the engine compartment. Fuel contact with hot engine or exhaust is a potential fire hazard.

- Do not permit any flame, cigarette, pilot light, spark, arcing equipment, or other ignition source near the generator set or fuel tank.
- Fuel lines must be adequately secured and free of leaks. Fuel connection at the engine should be made with an approved flexible line. Do not use copper piping on flexible lines as copper will become brittle if continuously vibrated or repeatedly bent.
- Make sure all fuel supplies have a positive (+) shutoff valve.
- Make sure the battery area has been well-ventilated prior to servicing near it. Lead-acid batteries emit a highly explosive hydrogen gas that can be ignited by arcing, sparking, smoking, etc.

1.5.1 Gaseous Fuels

Natural gas is lighter than air, and will tend to gather under covered areas.

1.5.2 Spillage

Any spillage that occurs during fueling, oil top-off, or oil change must be cleaned up before starting the generator set.

1.5.3 Fluid Containment

NOTICE

Where spillage containment is not part of a Cummins supply, it is the responsibility of the installer to provide the necessary containment to prevent contamination of the environment, especially water courses and sources.

Fluid containment is incorporated into the base of the generator set, it must be inspected at regular intervals. Any liquid present should be drained out and disposed of in accordance with local health and safety regulations. Failure to perform this action may result in spillage of liquids which could contaminate the surrounding area.

Any other fluid containment area must also be checked and emptied, as described above.

1.5.4 Do Not Operate in Flammable and Explosive Environments

Flammable vapor can cause an engine to overspeed and become difficult to stop, resulting in possible fire, explosion, severe personal injury, and death. Do not operate a generator set where a flammable vapor environment can be created, unless the generator set is equipped with an automatic safety device to block the air intake and stop the engine. The owners and operators of the generator set are solely responsible for operating the generator set safely. Contact your authorized Cummins distributor for more information.

1.6 Aftertreatment Systems

⚠ WARNING

Hot Surfaces

Contact with hot surfaces can cause severe burns.

Allow to cool before performing any service tasks. Wear appropriate PPE when working on hot equipment and avoid contact with hot surfaces.

⚠ WARNING**Toxic Gases**

Substances in exhaust gases have been identified by some state and federal agencies to cause cancer or reproductive toxicity.

Do not breathe in or come into contact with exhaust gases.

1.6.1 Selective Catalytic Reduction (SCR)

Selective Catalytic Reduction is used to reduce emissions such as Nitrous Oxide (NO_x) from engines in order to meet emissions standards.

DEF is periodically added to diesel engines (as an aqueous urea solution), and mixes with the exhaust gases to reduce Nitrogen Oxide content.

Ammonia is part of the process used by Selective Catalyst Reduction systems on engines which use Diesel Exhaust Fluid.

1.6.2 Diesel Exhaust Fluid (DEF)

- Do not get the substance in your eyes. In case of contact, immediately flush eyes with large amounts of water for a minimum of 15 minutes and seek medical advice/attention.
- Do not swallow. In the event the DEF is ingested seek medical advice/attention.
- Do not inhale (vapor). In the event DEF vapor is inhaled, immediately remove from further exposure and seek medical advice/attention.
- Do not spill DEF while filling to avoid damage of load cables.

1.6.2.1 Ammonia

Diesel Exhaust Fluid processing may release Ammonia gas.

- Ammonia is toxic, may be fatal if inhaled, ingested or absorbed.
- Ammonia is irritating to the skin, nose, throat, lungs and eyes and may cause blindness.

Wear appropriate PPE. Make sure there is adequate ventilation.

Reference the Materials Safety Data Sheet (MSDS) for additional information.

1.7 Exhaust Gases Are Deadly

- Provide an adequate exhaust system to properly expel discharged gases away from enclosed or sheltered areas, and areas where individuals are likely to congregate. Visually and audibly inspect the exhaust system daily for leaks per the maintenance schedule. Make sure that exhaust manifolds are secured and not warped. Do not use exhaust gases to heat a compartment.
- Make sure the unit is well ventilated.

1.7.1 Exhaust Precautions

⚠ WARNING**Hot Exhaust Gases**

Contact with hot exhaust gases can cause severe burns.

Wear personal protective equipment when working on equipment.

⚠ WARNING**Hot Surfaces**

Contact with hot surfaces can cause severe burns.

The unit is to be installed so that the risk of hot surface contact by people is minimized. Wear appropriate PPE when working on hot equipment and avoid contact with hot surfaces.

⚠ WARNING**Toxic Gases**

Inhalation of exhaust gases can cause asphyxiation and death.

Pipe exhaust gas outside and away from windows, doors, or other inlets to buildings. Do not allow exhaust gas to accumulate in habitable areas.

⚠ WARNING**Fire Hazard**

Contaminated insulation is a fire hazard. Fire can cause severe burns or death.

Remove any contaminated insulation and dispose of it in accordance with local regulations.

The exhaust outlet may be sited at the top or bottom of the generator set. Make sure that the exhaust outlet is not obstructed. Personnel using this equipment must be made aware of the exhaust position. Position the exhaust away from flammable materials - in the case of exhaust outlets at the bottom, make sure that vegetation is removed from the vicinity of the exhaust.

The exhaust pipes may have some insulating covers fitted. If these covers become contaminated they must be replaced before the generator set is run.

To minimize the risk of fire, make sure the following steps are observed:

- Make sure that the engine is allowed to cool thoroughly before performing maintenance or operation tasks.
- Clean the exhaust pipe thoroughly.

1.8 Earth Ground Connection

The neutral of the generator set may be required to be bonded to earth ground at the generator set location, or at a remote location, depending on system design requirements. Consult the engineering drawings for the facility or a qualified electrical design engineer for proper installation.

NOTICE

The end user is responsible to make sure that the ground connection point surface area is clean and free of rust before making a connection.

NOTICE

The end user is responsible for making sure that an earthing arrangement that is compliant with local conditions is established and tested before the equipment is used.

1.9 Distribution Panel Door

NOTICE

Opening the distribution panel door while the generator set is running will trip the generator set circuit breaker and abruptly shut off power to all loads. Make sure that the generator set is not running and is in off mode before you open the distribution panel door.

1.10 Transport and Towing

The generator set is capable of being towed on the highway or off the highway. Consult federal, state, and local transportation codes before transporting the generator set. Pay attention to the transportation codes that pertain to towing with fuel in the tanks. Some codes do not allow towing with fuel in the tank. When there are differences between the instructions in this manual and the federal, state, and local traffic laws, the federal, state, and local traffic laws take precedence.

Do the following to move or tow the generator set:

- Be sure the towing vehicle is adequate to tow and stop the generator set.
- Disconnect all customer connections/load cabling from the generator set.
- Disconnect the ground wire from the generator set.
- Drain the fuel from the generator set fuel tank as appropriate according to federal, state, and local transportation codes.

WARNING

Towing Hazard

Failure to properly secure the generator set trailer to the towing vehicle can result in serious injury or death.

Always use the proper trailer hitch and safety chains to attach the generator set trailer to the towing vehicle. Always obey all local and state laws when towing a generator set.

- Use the front leveling jack to raise the trailer hitch enough to secure the hitch to the vehicle. Be sure the hitch coupler is properly secured to the vehicle.
- Attach the safety chains to the vehicle.
- If included on the generator set, attach the breakaway chain on the surge brake and the electrical coupler to the vehicle.
- Fully retract the front leveling jack.
- Check the trailer tires for proper inflation.
- Be sure the wheel lug nuts are tight.
- If included on the generator set, connect the electrical connector for the towing lights to the vehicle.

NOTICE

Exceeding the recommended speeds can cause severe damage to the generator set which will void the manufacturer's warranty.

- Tow at the posted speeds for trailers or the following, whichever is least:
 - 60 mph (96 kph) on paved roads
 - 10 mph (16 kph) on unpaved roads

1.11 Beware of Traffic Hazards

- When the generator set is on or beside the road, be clear of traffic when starting, stopping, or checking the generator set.
- Be sure there are no oil or fuel leaks that can spill onto the road.
- Be sure that all fasteners and mounting brackets are tight. Be sure that fasteners and mounting brackets will not fall off during transit.

1.12 Tipping Hazard

⚠ WARNING***Tipping Hazard***

Tipping of the generator set can cause serious injury or death.

Be sure the generator set/trailer unit is placed on a level surface. The stabilization jacks must be properly and securely in place.

1.13 Decommissioning and Disassembly

NOTICE

Decommissioning and disassembly of the generator set at the end of its working life must comply with local guidelines and legislation for disposal/recycling of components and contaminated fluids. This procedure must only be carried out by suitably trained and experienced service personnel. For more information contact your authorized distributor.

This page is intentionally blank.

2 Introduction

⚠ WARNING

Hazardous Voltage

Contact with high voltages can cause severe electrical shock, burns, or death.

Make sure that only a trained and experienced electrician makes generator set electrical output connections, in accordance with the installation instructions and all applicable codes.

⚠ WARNING

Electrical Generating Equipment

Faulty electrical generating equipment can cause severe personal injury or death.

Generator sets must be installed, certified, and operated by trained and experienced persons in accordance with the installation instructions and all applicable codes.

2.1 About This Manual

The purpose of this manual is to provide the users with sound, general information. It is for guidance and assistance with recommendations for correct and safe procedures, which may from time to time be updated. It is the user's responsibility to ensure they are aware of any updates to this guidance before commencing operational activities. Cummins shall not be liable for any operational consequences arising as a result of not following the guidance outlined in this manual, nor for any discretionary actions taken by the user in response to recommendations outlined in this manual.

The information contained within the manual is based on information available at the time of going to print. In line with Cummins policy of continuous development and improvement, information may change at any time without notice. The users should therefore make sure that before commencing any work, they have the latest information available. The latest version of this manual is available on QuickServe Online (<https://quickserve.cummins.com>).

Users are respectfully advised that, in the interests of good practice and safety, it is their responsibility to employ competent persons to carry out any installation work. Consult your authorized distributor for further installation information. It is essential that the utmost care is taken with the application, installation, and operation of any engine due to their potentially hazardous nature. Careful reference should also be made to other Cummins literature. A generator set must be operated and maintained properly for safe and reliable operation.

For further assistance, contact your authorized distributor.

2.2 Schedule of Abbreviations

This list is not exhaustive. For example, it does not identify units of measure or acronyms that appear only in parameters, event/fault names, or part/accessory names.

ABBR.	DESCRIPTION	ABBR.	DESCRIPTION
AC	Alternating Current	LTS	Long Term Storage
AMF	Automatic Mains Failure	LVRT	Low Voltage Ride Through
AMP	AMP, Inc., part of Tyco Electronics	MCB	Main Generator set Circuit Breaker

ABBR.	DESCRIPTION	ABBR.	DESCRIPTION
ANSI	American National Standards Institute	MFM	Multifunction Monitor
ASOV	Automatic Shut Off Valve	Mil Std	Military Standard
ASTM	American Society for Testing and Materials (ASTM International)	MLD	Masterless Load Demand
ATS	Automatic Transfer Switch	MRS	Manual Remote Start
AVR	Automatic Voltage Regulator	NC	Normally Closed
AWG	American Wire Gauge	NC	Not Connected
CAN	Controlled Area Network	NFPA	National Fire Protection Agency
CB	Circuit Breaker	NO	Normally Open
CE	Conformité Européenne	NWF	Network Failure
CFM	Cubic Feet per Minute	OEM	Original Equipment Manufacturer
CGT	Cummins Generator Technologies	OOR	Out of Range
CMM	Cubic Meters per Minute	OORH / ORH	Out of Range High
CT	Current Transformer	OORL / ORL	Out of Range Low
D-AVR	Digital Automatic Voltage Regulator	PB	Push Button
DC	Direct Current	PCC	PowerCommand® Control
DEF	Diesel Exhaust Fluid	PGI	Power Generation Interface
DPF	Diesel Particulate Filter	PGN	Parameter Group Number
ECM	Engine Control Module	PI	Proportional/Integral
ECS	Engine Control System	PID	Proportional / Integral / Derivative
EMI	Electromagnetic interference	PLC	Programmable Logic Controller
EN	European Standard	PMG	Permanent Magnet Generator
EPS	Engine Protection System	PPE	Personal Protective Equipment
E-Stop	Emergency Stop	PT	Potential Transformer
FAE	Full Authority Electronic	PTC	Power Transfer Control
FMI	Failure Mode Identifier	PWM	Pulse-width Modulation
FRT	Fault Ride Through	RFI	Radio Frequency Interference
FSO	Fuel Shutoff	RH	Relative Humidity
Genset	Generator Set	RMS	Root Mean Square
GCB	Generator set Circuit Breaker	RTU	Remote Terminal Unit
GCP	Generator Control Panel	SAE	Society of Automotive Engineers
GND	Ground	SCR	Selective Catalytic Reduction
LCT	Low Coolant Temperature	SPN	Suspect Parameter Number

ABBR.	DESCRIPTION	ABBR.	DESCRIPTION
HMI	Human-machine Interface	SWL	Safe Working Load
IC	Integrated Circuit	SW_B+	Switched B+
ISO	International Organization for Standardization	UL	Underwriters Laboratories
LBNG	Lean-burn Natural Gas	UPS	Uninterruptible Power Supply
LCD	Liquid Crystal Display	VPS	Valve Proving System
LED	Light-emitting Diode		

2.3 Related Literature

Before any attempt is made to operate the generator set, the operator should take time to read all of the manuals supplied with the generator set and familiarize themselves with the warnings and operating procedures.

CAUTION

A generator set must be operated and maintained properly if you are to expect safe and reliable operation. The Operator Manual includes a maintenance schedule and a troubleshooting guide.

The Health and Safety Manual must be read in conjunction with this manual for the safe operation of the generator set:

- Health and Safety Manual (0908-0110)

The relevant manuals appropriate to your generator set are also available, the documents below are in English.

- Installation Manual for C2750D6E and C3000D6EB with QSK78 Engine and PowerCommand® 3.3 or 3.3 MLD and S9 Alternator (A075L574)
- Operator Manual for C2750D6E and C3000D6EB with QSK78 Engine and PowerCommand® 3.3 or 3.3 MLD and S9 Alternator (A075L575)
- Service Manual for C2750D6E and C3000D6EB with QSK78 Engine and PowerCommand® 3.3 or 3.3 MLD and S9 Alternator (A075L576)
- Control Service Manual for PowerCommand® 3.3 (900-0670)
- Engine Operation and Maintenance Manual for QSK78 (5677186)
- Alternator Service Manual for S9 (A062L877)
- S-6763 *Specification and Data Sheet* (for engineering data specific to the generator set)
- T-030, *Liquid Cooled Generator Set Application Manual* (for application information)
- Parts Manual for C2750D6E and C3000D6EB (A076F900)
- Standard Repair Times - BK Family (0900-0904)
- Recommended Spares List (RSL) for C2750D6E (A075N340)
- Recommended Spares List (RSL) for C3000D6EB (A075N341)
- Warranty Administration Manual (4021290)
- Global Commercial Warranty Statement (A072R157)

2.3.1 Further Information - Literature

Contact your authorized distributor for more information regarding related literature for this product.

2.4 After Sales Services

Cummins offers a full range of maintenance and warranty services.

2.4.1 Maintenance

WARNING

Electrical Generating Equipment

Incorrect operation and maintenance can result in severe personal injury or death.

Make sure that only suitably trained and experienced service personnel perform electrical and/or mechanical service.

For expert generator set service at regular intervals, contact your local distributor. Each local distributor offers a complete maintenance contract package covering all items subject to routine maintenance, including a detailed report on the condition of the generator set. In addition, this can be linked to a 24-hour call-out arrangement, providing year-round assistance if necessary. Specialist engineers are available to maintain optimum performance levels from generator sets. Maintenance tasks should only be undertaken by trained and experienced technicians provided by your authorized distributor.

2.4.2 Warranty

For details of the warranty coverage for your generator set, refer to the Global Commercial Warranty Statement listed in the Related Literature section.

In the event of a breakdown, prompt assistance can normally be given by factory trained service technicians with resources to undertake all minor and many major repairs to equipment on site.

Extended warranty coverage is also available.

For further warranty details, contact your authorized service provider.

NOTICE

Damage caused by failure to follow the manufacturer's recommendations will not be covered by warranty. Contact your authorized service provider.

2.4.2.1 Warranty Limitations

For details of the warranty limitations for your generator set, refer to the warranty statement applicable to the generator set.

2.4.3 How to Obtain Service

When a product requires servicing, contact the nearest Cummins service provider. To locate the distributor, go to www.cummins.com/support and select Find a Sales or Service Location. When contacting the service provider, always supply the complete model, specification, and serial number as shown on the nameplate.

2.4.3.1 Locating a Distributor

In the U.S. and Canada

To easily locate the nearest certified distributor/dealer for Cummins generator sets in your area, or for more information, contact us at 1-800-CUMMINS™ (1-800-286-6467) or visit www.cummins.com/support.

If unable to contact a distributor using the automated service, consult the Internet.

If unable to arrange a service or resolve an issue, contact the Service Manager at the nearest Cummins distributor for assistance.

When contacting the distributor, always supply the complete Model, Specification, and Serial Number as shown on the product nameplate.

This page is intentionally blank.

3 System Overview

This section provides an overview of the generator set.

3.1 Generator Set Identification

Each generator set is provided with a nameplate similar to that shown below. The nameplate provides information unique to the generator set.

3.1.1 Nameplate

Model No.			
Serial No.		Spec.	
FREQUENCY: 50 HZ			
SERVICE RATING:			
PHASE: 3PH 3PH			
RATED PWR KVA:			
KW:			
POWER FACTOR: 0.8 0.8			
CONNECTIONS:			
BATTERY: VDC			
VOLTS AMPS AMPS			
1805			
1805/3300			
ROTATING SPEED: 1500 RPM			
PERFORMANCE CLASS			
150 8500-1: G3 G3			
FUEL:			
MAX. FLOW:			
GENERATOR SET MAXIMUM WEIGHT FOR			
DODGE 6.0L/5.9-REG MAX/LBS MAX: 15221 KG5 / 33556 LBS			
WIRING DIAGRAM:			

Model No.			
Serial No.		Spec.	
FREQUENCY: 60 HZ			
SERVICE RATING:			
PHASE: 3PH 3PH			
RATED KW:			
POWER FACTOR: 0.8 0.8			
RATED KVA:			
12 CAPABILITY:			
CONNECTIONS:			
BATTERY: VOLTS AMPS AMPS			
VDC 2400			
2400/4160			
ROTATING			
SPEED:			
1600RPM			
NOMINAL			
RATED			
FUEL:			
WIRING DIAGRAM:			

FIGURE 1. TYPICAL GENERATOR SET NAMEPLATE

3.2 Generator Set Components

The main components of a typical generator set are shown below, and referred to in this section.

Various options are listed although they may not be available for all models.

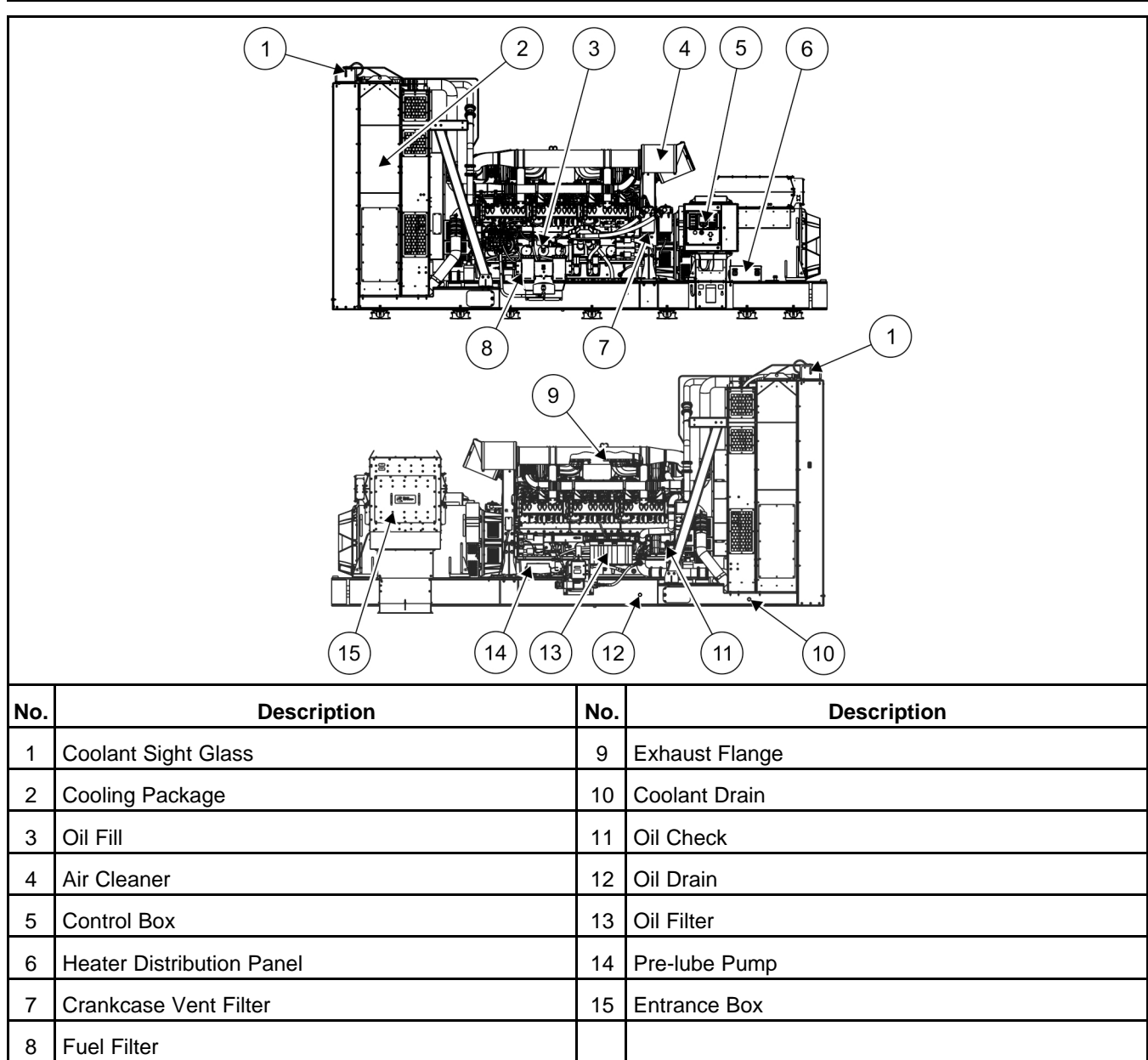

FIGURE 2. GENERATOR SET WITH CIRCUIT BREAKER BOX OR ENTRANCE BOX

3.3 Generator Set Performance Data

3.3.1 Acoustic Information 60 Hz (1800 RPM)

TABLE 1. ACOUSTIC DATA 60 HZ (1800 RPM)

Model	Engine	Open Set Acoustic Data ¹	Enclosed Set Acoustic Data ²
C2750D6E	QSK78	134.5	Enclosed set acoustic data is not available for these models
C3000D6EB	QSK78	135.2	

Model	Engine	Open Set Acoustic Data ¹	Enclosed Set Acoustic Data ²
<p>1. Open Set Acoustic Data – dB(A) at 1m – SPL (or enclosed set with doors open)</p> <ul style="list-style-type: none"> • Based on 100% load <p>2. Enclosed Set Acoustic Data - Based on using a standard Cummins' canopy, and 60 Hz set operating with doors closed</p> <ul style="list-style-type: none"> • Doors closed figures are measured using 2000/14/EC guaranteed sound power levels • Based on 75% load <p>For Noise Spectrum Figures, refer to your authorized distributor. In line with the Cummins Inc. policy of continuous improvement, these figures are subject to change.</p>			

3.3.2 Generator Set Fuel Consumption

TABLE 2. FUEL CONSUMPTION L/HR (GAL/HR) AT 1800 RPM (60 HZ)

Model	Engine	Fuel Consumption Data at 60 Hz ¹
C2750D6E	QSK78-G36	738.7 L/hr (195.1 gal/hr)
C3000D6EB	Low NOx QSK78-G36	823.4 L/hr (217.5 US gal/hr)
C3000D6EB	QSK78-G37	773.2 L/hr (204.3 US gal/hr)
<p>1. Standby/Full Load Refer to data sheets for other applications. In line with the Cummins Inc. policy of continuous improvement, these figures are subject to change.</p>		

3.4 Engine

For additional engine specific information, refer to the relevant engine manual for the generator set.

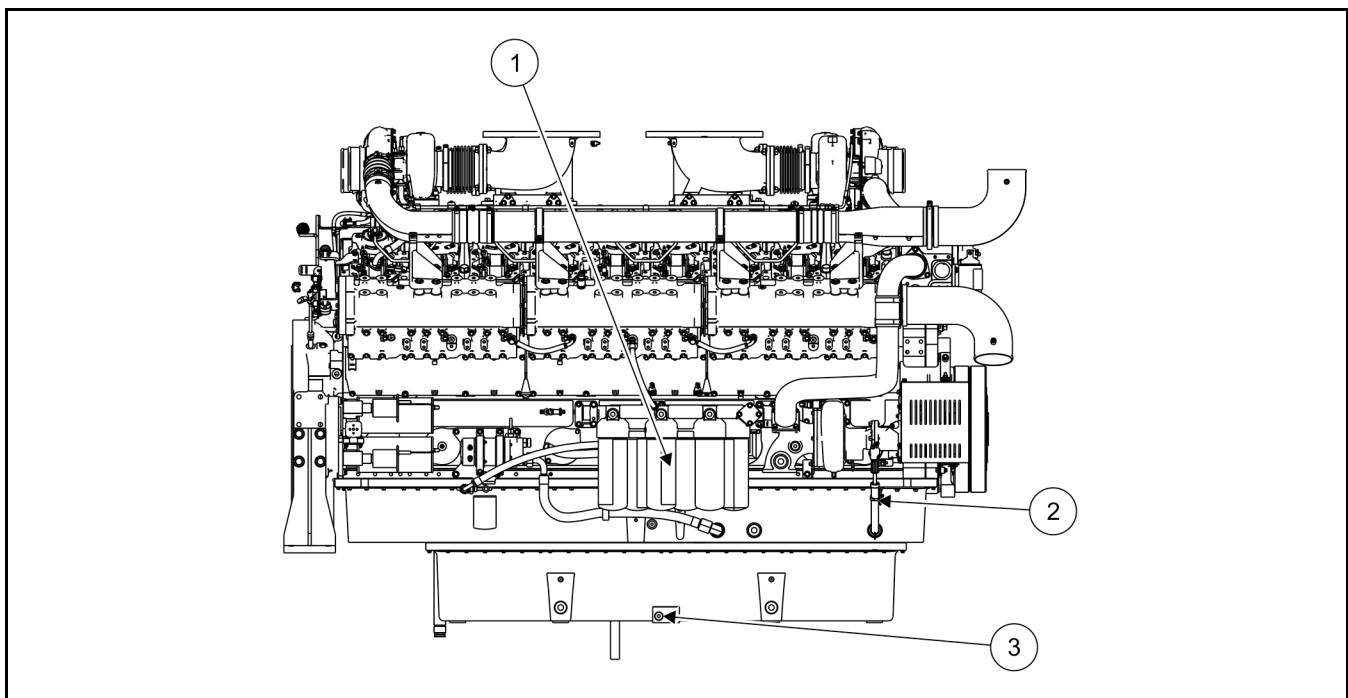

No	Description
1	Oil Filters
2	Dipstick
3	Oil Drain

FIGURE 3. TYPICAL ENGINE COMPONENTS (QSK78)

3.4.1 Fuel Changeover System

NOTICE

Do not operate the generator set with the blanking plugs fitted and the valves set to external tank supply. This will cause damage to the engine’s fuel system.

NOTICE

Consult your authorized distributor to establish the maximum head of fuel allowable at the generator set fuel pump.

A 3-way fuel valve system is provided to enable the generator set to be fuelled directly from an external tank.

Where the system comprises two valves it is essential that both valves are in the same position to prevent the following:

- Fuel spillage from the generator set tank vent; when fuel is drawn from the external tank and spill returned to the generator set tank.
- Fuel shortage; when fuel is drawn from the generator set tank and spill returned to the external tank.

3.5 Cooling System Components

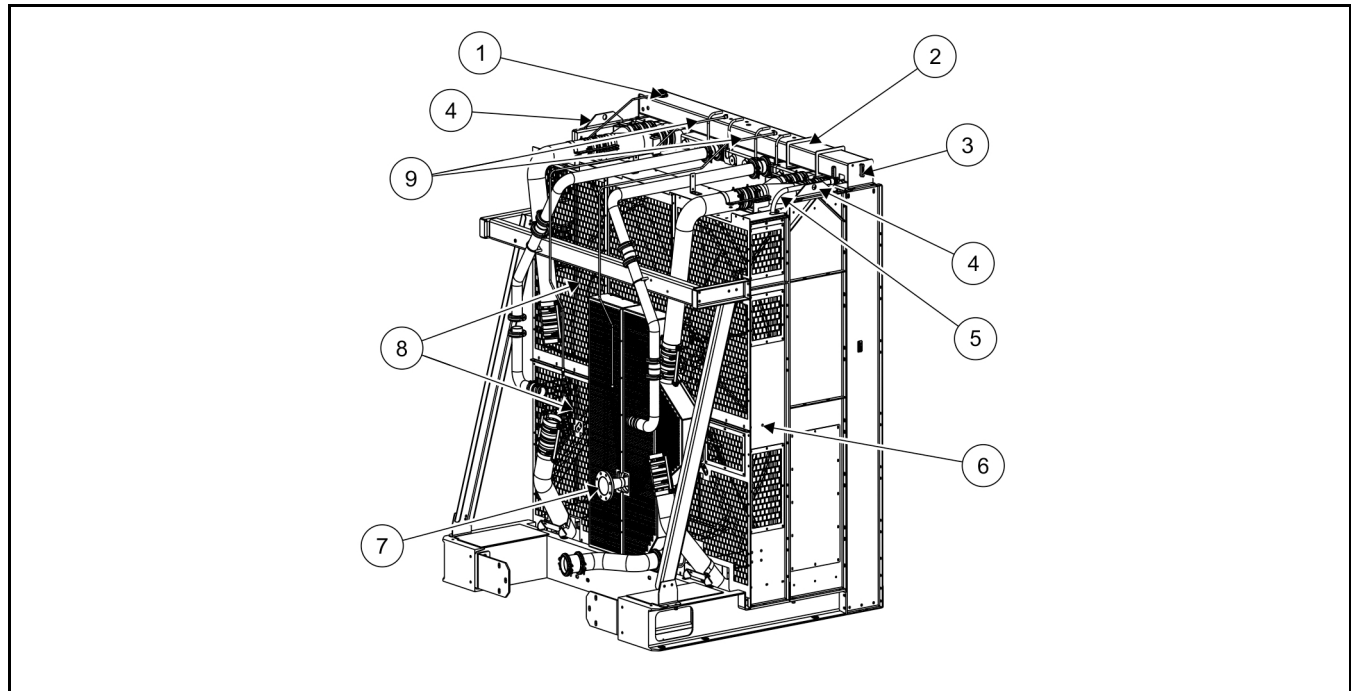

No.	Description	No.	Description
1	Coolant Fill	6	Bearing Grease Fittings
2	Radiator	7	Drive Shaft
3	Sight Glass	8	Fan Guards
4	Lifting Eye	9	Vent Ports
5	Vent Hose		

FIGURE 4. COOLING SYSTEM

3.6 Sensors

Various generator set parameters are measured by sensors, and the resulting signals are processed by the control board.

Engine-mounted sensors monitor a number of different systems, such as:

- Lube Oil Pressure
- Cooling System Temperature

3.7 Pyrometers - Engine Exhaust

A pyrometer measures engine exhaust gas temperature. A separate temperature meter is used to monitor each exhaust outlet elbow.

3.8 Heaters

3.8.1 Heater Supply and Isolation

A power supply is required for the operation of all heaters (engine, coolant, and alternator), if fitted.

NOTICE

It is the sole responsibility of the customer to provide the power supply and the means to isolate the AC input to the terminal box. Cummins accepts no responsibility for providing the means of isolation. Contact your distributor for more information.

NOTICE

This disconnecting device is not provided as part of the generator set.

3.8.2 Coolant Heater

NOTICE

**Operating the heater or heaters when the coolant system has been drained, or there is a suspicion that the coolant is frozen, can result in equipment damage.
Always make sure the coolant is not frozen and the radiator is filled to the recommended level before energizing the heater or heaters.**

A coolant heater keeps the engine coolant warm when the engine is shut down. It heats and circulates the coolant within the engine. This reduces start-up time and lessens engine wear caused by cold starts. It is electrically operated and thermostatically controlled.

3.9 Air Cleaner

An air cleaner includes an element that must be replaced periodically. Some air cleaners include a service indicator that indicates when an air cleaner element is dirty and must be replaced.

3.9.1 Normal Duty Air Cleaner

The normal duty air cleaner is used in environments with good quality air and low volume air particle contaminants.

See [Section 3.12 on page 28](#) for optional air cleaners.

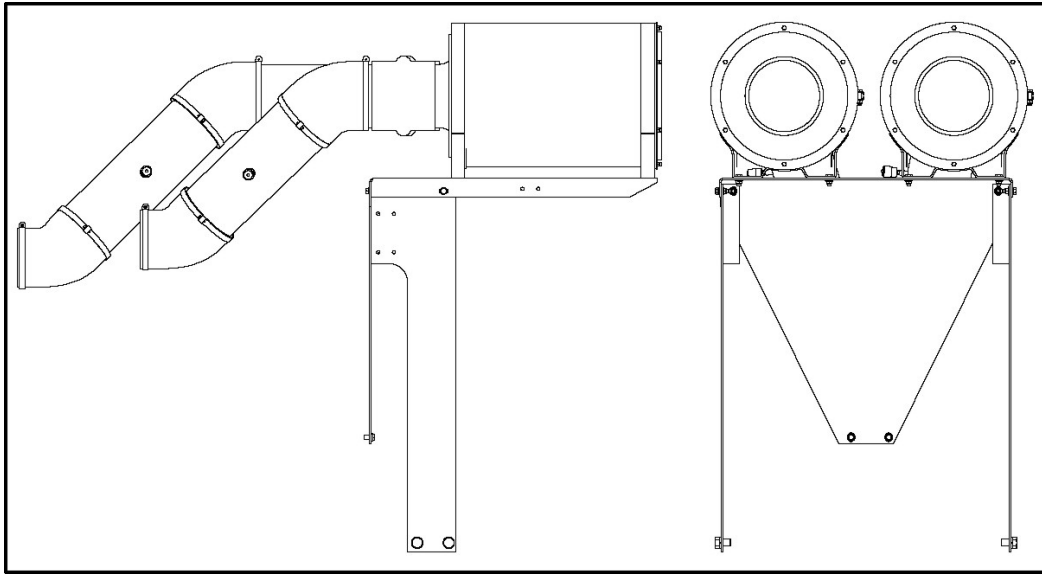

FIGURE 5. NORMAL AIR CLEANER ASSEMBLY

3.10 External Emergency Stop Switch

Push the emergency stop switch for emergency shutdown of the generator set. This button stops the generator set immediately and prevents starting of the set from any location (local or remote). The emergency stop shutdown can be reset only at the generator set control panel. To reset the emergency stop switch:

1. Push and twist the external button to release.
2. Turn the O/Manual/Auto switch to O (Off).
3. Press the front panel Fault Acknowledge/Reset button.
4. Select Manual or Auto, as required.

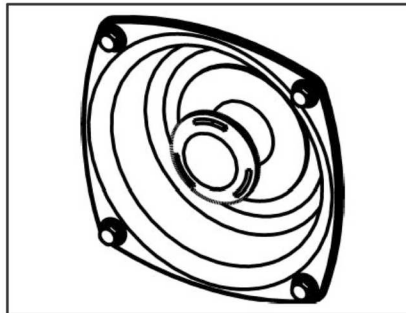
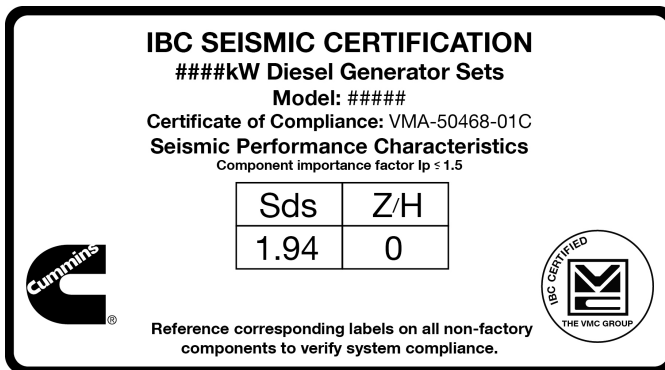

FIGURE 6. EXTERNAL EMERGENCY STOP SWITCH

3.11 Seismic IBC Labelling



This label indicates that this generator set is IBC compliant.

NOTICE

Reference corresponding labels on all non-factory components to verify system compliance.

3.12 System Options

3.12.1 Battery Charger

The single-phase, utility-powered battery charger is a constant voltage, current limited type that monitors the battery and supplies current as needed to maintain a fully charged condition without over-charging.

The charger's electronic control circuit allows the charger to be left in-circuit during engine cranking and to operate in parallel with the engine charging alternator.

3.12.2 Battery Charger – Set Mounted

NOTICE

It is the sole responsibility of the Customer to provide the power supply and the means to isolate the supply to the charger. Cummins accepts no responsibility for providing the means of isolation.

NOTICE

The AC supply must be installed using correctly sized conductors with appropriate overcurrent and earth fault protection to comply with local electrical codes and regulations.

Single phase, mains (utility) powered battery chargers, which are set mounted, are available to maintain the battery in a charged condition when the generator set is not running.

Provisions for mounting the battery charger, and the Customer's single phase AC connections for the battery charger, are on the generator set control housing.

A separate disconnecting device is required by BS EN 12601:2001.

3.12.3 Battery Charger - 20 Amp/24 Volt

The 20 amp battery charger is fully automatic, constant voltage/constant current, and incorporates a 4-stage charging algorithm for optimum battery life. It is configurable for 24 VDC battery systems at 60 Hz.

The four-stage charge cycles are:

- Constant current: The charger operates at maximum possible output in the fast charge mode.
- High-rate taper: The charger stays at fast charge voltage level until battery current acceptance falls to a portion of the chargers rated output.
- Finishing: The charger operates at the float voltage and completes the battery charge.
- Maintenance charge cycle: The charger supplies only a few milliamps required by the battery to stay at peak capability.

3.12.3.1 Features

Some of the battery charger features include:

- Surge Protection to IEEE and EN standards
- Convenient Input and Output Connections
- Battery Charger Status Display
- Adjustable Float Voltage
- Corrosion Resistant Aluminum Construction
- Fault Annunciation
- Vibration Resistant Design
- Five Year Warranty

3.12.3.2 Battery Charger Display

The battery charger user display indicates output voltage/current, fault information/status, and precision ammeter/voltmeter readings. LED indicators show the charger condition.

LEDs on the right indicate operational functions for:

- Temperature Compensation (TCOMP ACTIVE) (green)
- AC Voltage (AC ON) (green)
- Float Status (FLOAT MODE) (Green)
- Boost Status (BOOST MODE) (Amber)
- Battery Fault (BATT FAULT) (Red)

LEDs on the left are red when:

- There is a charger failure (CHG FAIL)
- There is high or low VDC (DC HIGH, DC LOW)
- The AC fails to occur (AC FAIL)

3.12.3.3 Battery Charger Display Location

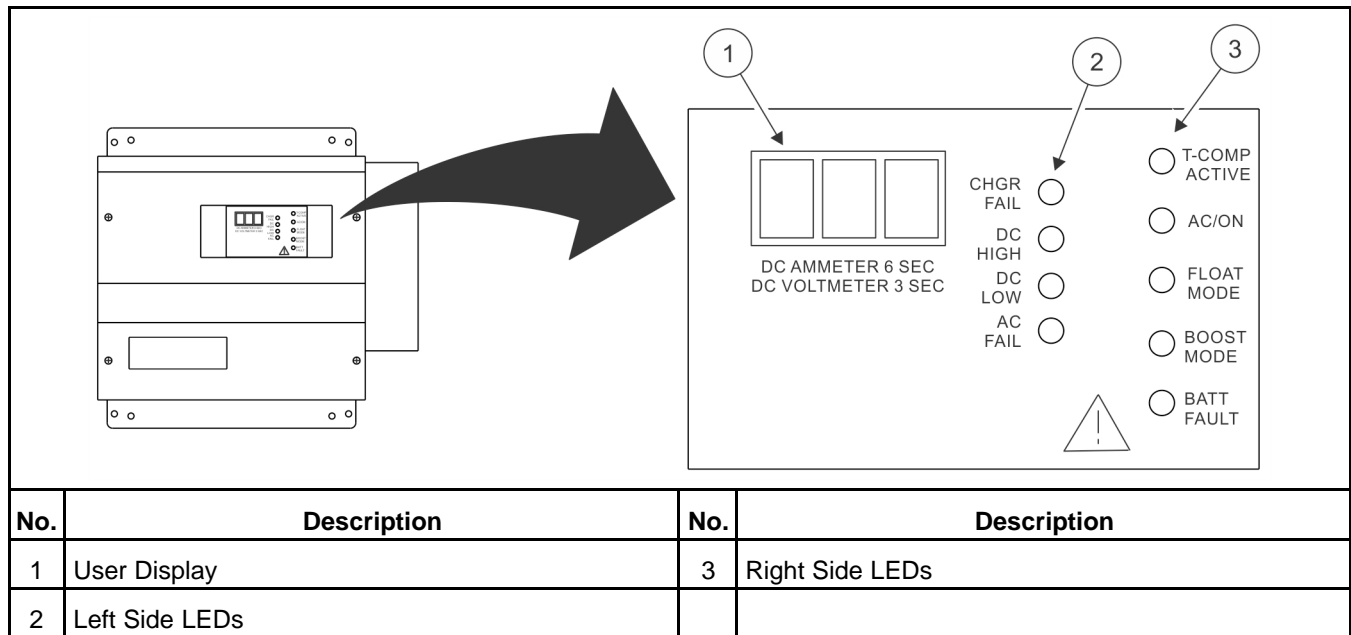

FIGURE 7. BATTERY CHARGER DISPLAY LOCATION

3.12.4 PowerCommand Universal Annunciator

A universal annunciator provides lamps and a horn to annunciate the operating status and fault conditions of an emergency power system. It is designed for connection to either a 12 VDC or a 24 VDC control system. It can be configured to be either a positive or negative signal device.

Two versions of the PowerCommand universal annunciator are available.

- Panel Mounted
- Panel with Enclosure

The universal annunciator can communicate using either a PCCNet or a Modbus network.

Refer to the PowerCommand Universal Owners Manual for more information.

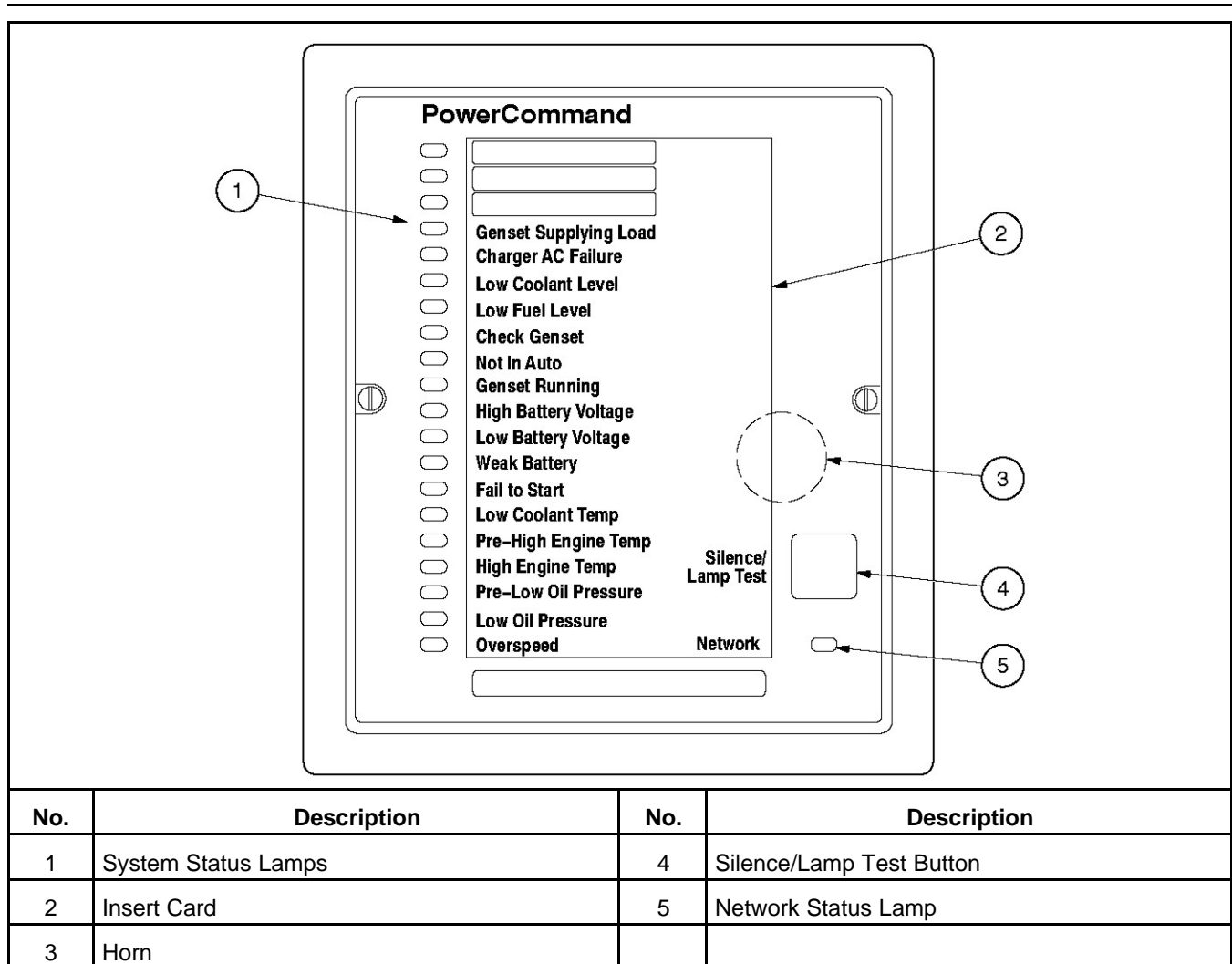

FIGURE 8. ANNUNCIATOR COMPONENTS

3.12.5 Mechanical Run-time Recorder

An Independent mechanical run-time recorder provides a visual view of the generator set run hours. Monitoring the generator set run hours on a regular basis, will ensure that the correct maintenance is performed at the right time.

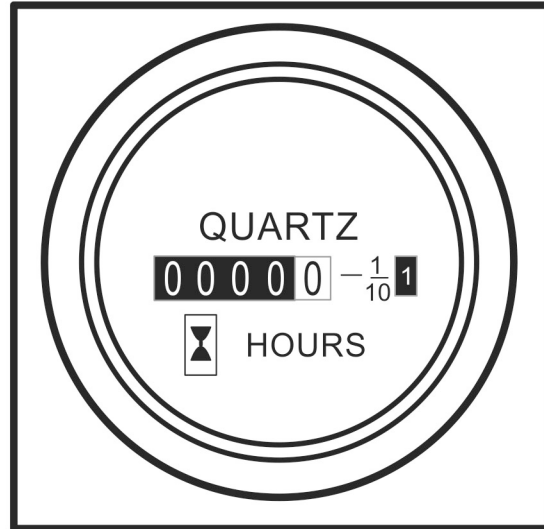

FIGURE 9. TYPICAL MECHANICAL RUN-TIME RECORDER

- Counting range: 10,000 hour version standard, with automatic recycle to zero.
- Accuracy: $\pm 0.02\%$
- Supply: 24 Vdc from batteries “Switched B +” power

3.12.6 Oil Sampling Valve

The oil sampling valve is a means of taking live oil samples from the engine to provide a sample for analysis. The valve is located on the inlet side of the oil filters to capture a sample before being filtered.

The sample to be used for analysis must be representative of the oil in the engine.

It is also important to conduct oil analysis on new (unused) oil to establish a baseline. New (unused) oil analysis samples should be taken twice a year or each time the oil type is changed at a minimum. Samples should be taken from the bulk supply tanks to determine the makeup of the oil and also to confirm that no contaminants are being introduced by the storage system.

3.12.7 Oil Maintainer System

The oil maintainer system includes a oil level regulator and connection points. An auxiliary oil tank and tank mounting hardware is provided by the end user.

The oil maintainer system ensures a proper level of engine lubricating oil.

NOTICE

The regulator should not be used as an oil level sight glass. The oil regulator does not accurately reflect the level of oil in the engine oil pan.

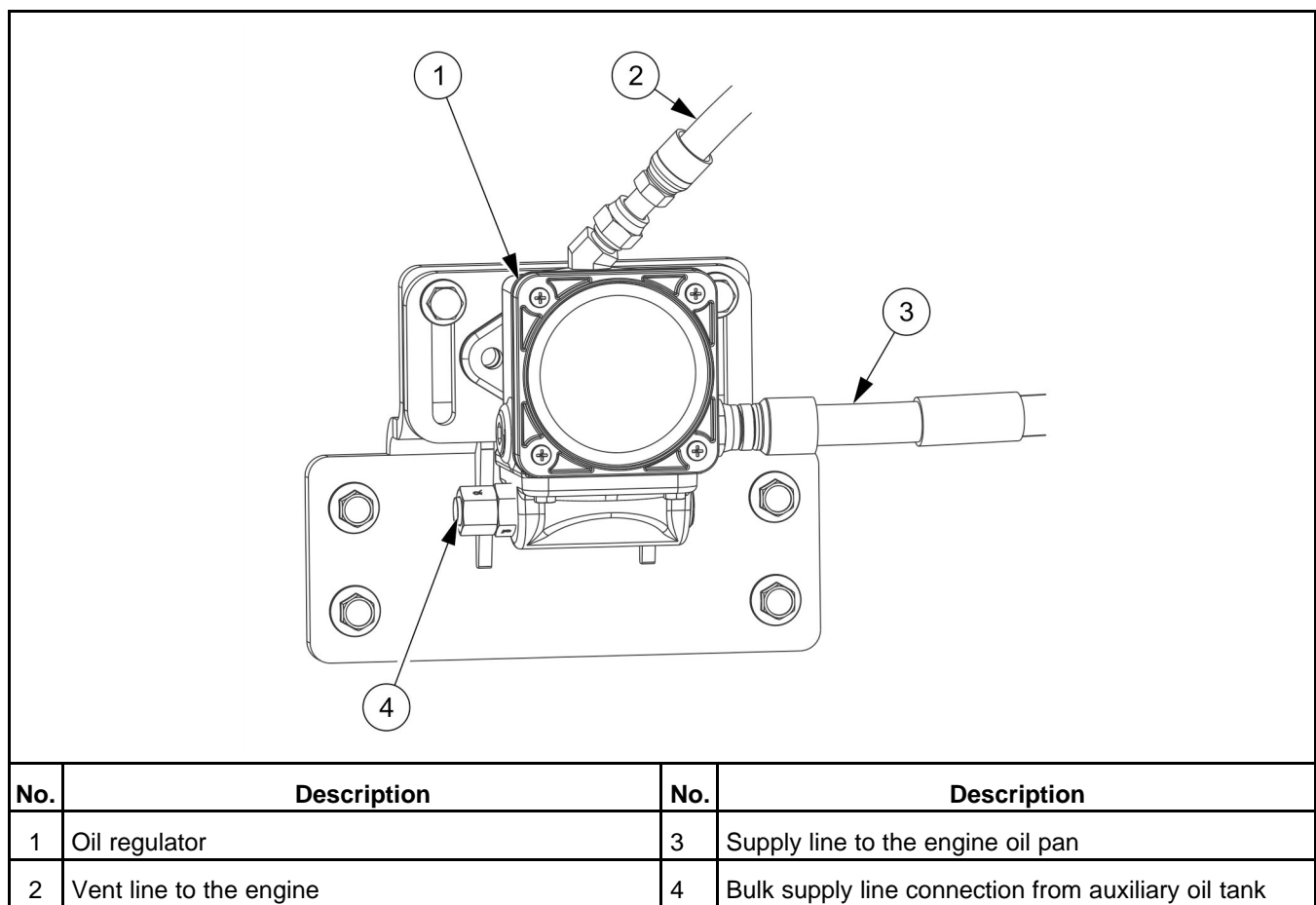

FIGURE 10. OIL MAINTAINER

3.12.8 Coolant Heater

NOTICE	
<p>Operating the heater or heaters when the coolant system has been drained, or there is a suspicion that the coolant is frozen, can result in equipment damage.</p> <p>Always make sure the coolant is not frozen and the radiator is filled to the recommended level before energizing the heater or heaters.</p>	

A coolant heater keeps the engine coolant warm when the engine is shut down. It heats and circulates the coolant within the engine. This reduces start-up time and lessens engine wear caused by cold starts. It is electrically operated and thermostatically controlled.

3.12.9 Heater Distribution Panel

The heater distribution panel provides a centralized power source for alternator and control panel heater systems.

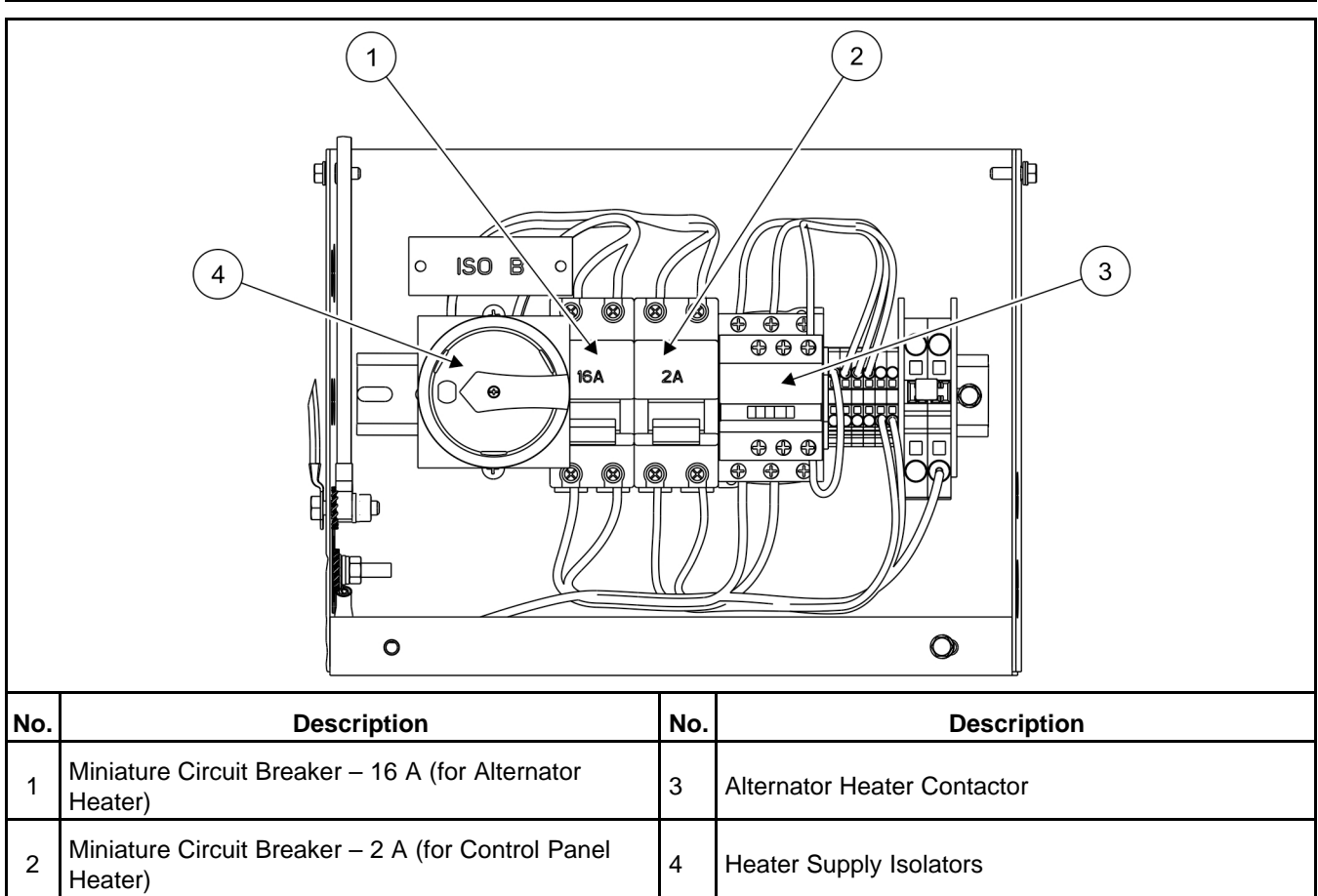

FIGURE 11. OIL MAINTAINER

4 Control System - PowerCommand 3.3

4.1 Control System Description

The control system is used to start and stop the generator set from the display screen in either Manual or Auto mode. It is suitable for standalone or paralleling generator sets in both standby and prime-power applications, providing full generator set monitoring capability and protection. It monitors the engine for temperature, oil pressure and speed, and provides voltage and current metering. In the event of a fault the unit indicates the fault type and automatically shuts down the generator set on critical faults.

All indicators, control buttons and the display screen are on the face of the operator panel as illustrated in the following figure.

There are two fault level signals generated by the control system as follows:

- **Warning:** signals an imminent or non-critical fault for the engine. The control provides an indication only for this condition.
- **Shutdown:** signals a potentially critical fault for the engine. The control immediately takes the engine off-load and automatically shuts it down.

The standard control system operates on 12 VDC or 24 VDC battery power. The auxiliary equipment operates on LV AC power. The history data is stored in non-volatile memory and is not deleted if battery power is lost.

4.1.1 Control System Panel

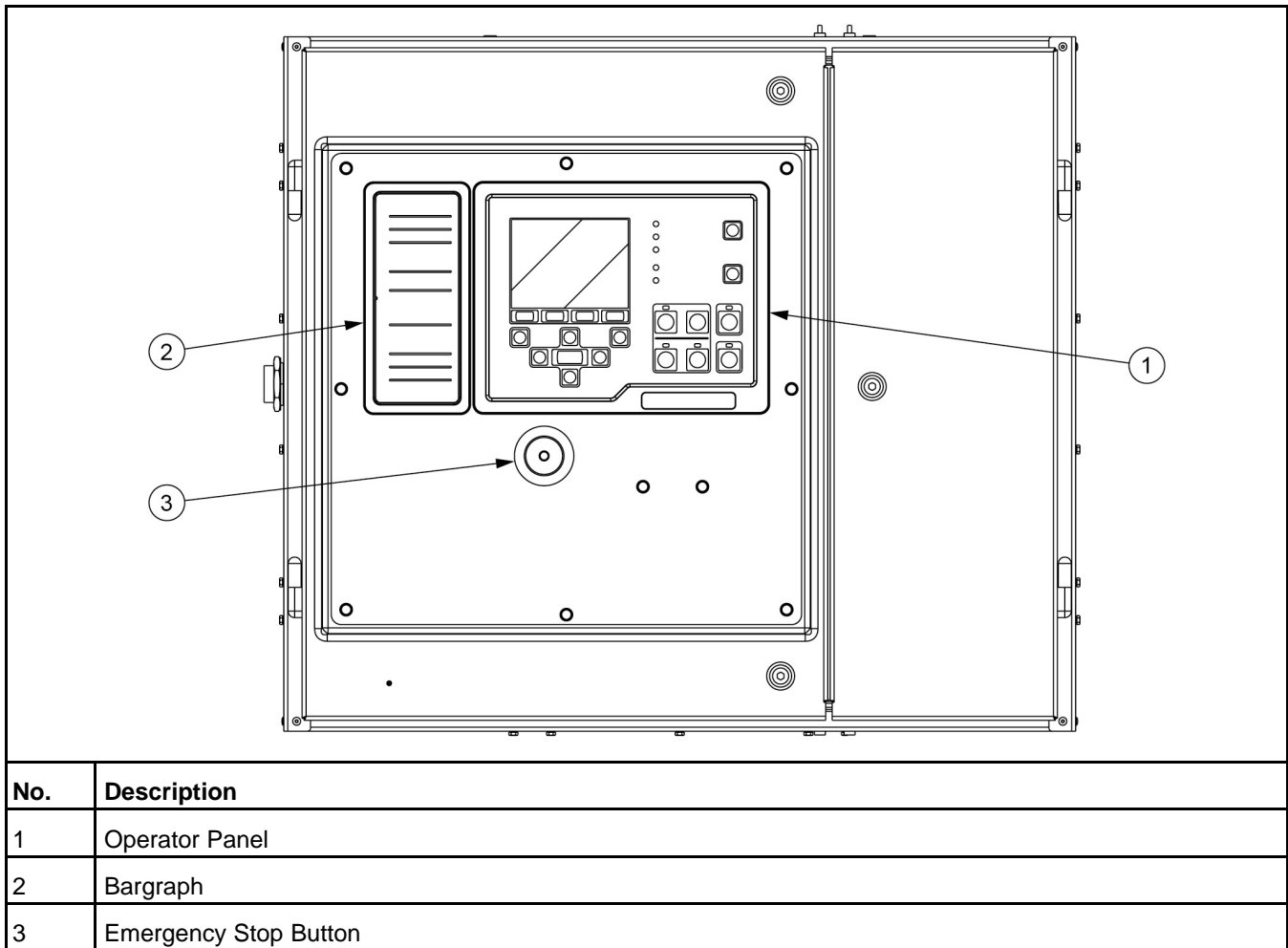

FIGURE 12. TYPICAL CONTROL SYSTEM PANEL (HMI 330)

4.1.2 Operating Modes

The PowerCommand® 3.3 control is operated by the **Start/Stop/Manual/Auto** buttons on the Operator Panel. Refer to [Figure 13 on page 40](#).

NOTICE

If the Mode Change access feature is enabled, a password is required to use these buttons to change the mode of operation. Contact your authorized distributor for options.

4.1.2.1 Stop Button

Press this button to put the generator set into the Off mode. This disables Auto and Manual modes. The green lamp above this button lights when the generator set is in the Off mode.

If the generator set is running, in either Manual or Auto mode, and the **Stop** button is pressed, the engine shuts down.

Refer to the Selecting Operating Modes section for more information on stopping in Auto or Manual mode.

NOTICE

If possible, hot shutdown under load should be avoided to help prolong the reliability of the generator set.

4.1.2.2 Manual Button



Press this button to put the generator set into the Manual mode. The **Start** button must then be pressed within ten seconds. Failure to do this results in the control mode defaulting, putting the generator set into the Off mode.

The green lamp above this button is lit when the generator set is in Manual mode.

NOTICE

If the Mode Change access password feature is enabled, the password must be entered before pressing the Start button. See the Passwords and Mode Change section.

4.1.2.3 Start Button



When the **Manual** button is pressed, this **Start** button must be pressed within ten seconds to start the generator set. The generator set starts up normally but without the Time Delay to Start.

In other modes, this button has no effect.

NOTICE

If the Start button is not pressed within the ten seconds of pressing the Manual button, the generator set mode changes to the Off mode automatically.

4.1.2.4 Auto Button



Press this button to put the generator set into the Auto mode. In this mode, the generator set is controlled by a remote switch or device (e.g. transfer switch).

The green lamp above this button lights when the generator set is in Auto mode.

4.1.2.5 Battle Short Mode

⚠ WARNING

Automated Machinery

Battle Short mode overrides some parameters of generator set control. Unmonitored generator sets can cause a fire or electrical hazard, resulting in severe personal injury or death.

Make sure that the operation of the set is supervised during Battle Short operation.

Battle Short mode is not a distinct mode of operation. The PowerCommand® control is still in the Off, Manual, or Auto mode while Battle Short mode is active. The PowerCommand® control still follows the appropriate sequence of operation to start and stop the generator set. Battle Short mode is a generator set mode of operation that prevents the generator set from being shut down by all but a few, select, critical shutdown faults.

The purpose of Battle Short mode is to satisfy local code requirements, where necessary. To use this feature, the necessary software must be installed at the factory when the PowerCommand® control is purchased. Only authorized service personnel can enable this feature. When shipped from the factory, this feature is disabled.

NOTICE

The Battle Short feature must be enabled or disabled using the InPower service tool.

This feature must only be used during supervised, temporary operation of the generator set. The faults that are overridden when in Battle Short mode can affect generator set performance, or cause permanent engine, alternator or connected equipment damage.

NOTICE

If this mode of operation is selected, the protection of load devices will be disabled. Cummins will not be responsible for any claim resulting from the use of this mode.

NOTICE

All shutdown faults, including those overridden by Battle Short, must be acted upon immediately to ensure the safety and well-being of the operator and the generator set.

Battle Short is turned on or off with an external switch connected to one of the two customer configured inputs or a soft switch on the operator panel.

When enabled, **Battle Short** switch input can be set using a Setup menu. To turn Battle Short mode on using the soft switch in the operator panel, **Battle Short** must be set to "Operator Panel" and enabled using the InPower service tool (default is Inactive).

When Battle Short mode is enabled, the Warning status indicator lights and code "1131 – Battle Short Active" is displayed.

When Battle Short mode is enabled and an overridden shutdown fault occurs, the shutdown lamp remains lit even though the set continues to run. "Fault code 1416 – Fail to Shutdown" is displayed. If the fault is acknowledged, the fault message is cleared from the display but remains in the Fault History file as long as Battle Short mode is enabled.

Battle Short is suspended and a shutdown occurs immediately if any of the following critical shutdown faults occur:

- Speed Signal Lost (Loss of Speed Sense) - Fault code 121
- Overspeed - Fault code 234
- Local Emergency Stop - Fault code 1433
- Remote Emergency Stop - Fault code 1434
- Excitation Fault (Loss of Voltage Sense) - Fault code 2335

Or

The Battle Short feature is disabled after an overridden shutdown fault occurred while in Battle Short mode. Fault code "1123 – Shutdown After Battle Short" is then displayed.

4.1.3 Power On and Sleep Modes

The operating modes of the control panel and operating software are Power On and Sleep.

Power On Mode

In this mode, power is continuously supplied to the control panel. The control's operating software and control panel lamps/graphical display remain active until the Sleep mode is activated.

Sleep Mode

Sleep mode is used to reduce battery power consumption when the control is not being used and it is in the Off or Auto mode. In this mode, the control's operating software is inactive and the lamps and graphical display on the control panel are all off.

When all conditions are met (i.e. no unacknowledged faults and the control is in the Off/Auto mode), the sleep mode activates after five minutes of keypad inactivity. This length of time is configurable.

To activate the control and view the menu display without starting the generator set, press any control button.

NOTICE

Sleep mode can be enabled/disabled. Contact your authorized distributor for options.

4.1.4 AmpSentry Maintenance Mode

AmpSentry Maintenance Mode (AMM) is an instantaneous overcurrent relay. With AMM enabled, if the control senses current in excess of 300% of nominal standby current in any of the three phases, the generator set will shut down instantaneously, bypassing any time delays. AMM reduces the risk of injury due to arc flash.

Qualified service technicians can enable AMM either by plugging the InPower Service tool into the control or by configuring customer inputs.

4.2 Operator Panel

Figure 13 shows the features of the front panel. It includes five lamp indicators; the graphical display with four menu select and seven menu navigation buttons; and six control mode buttons. This display panel enables the operator to look at the status, adjust the settings, and start and stop the generator set.

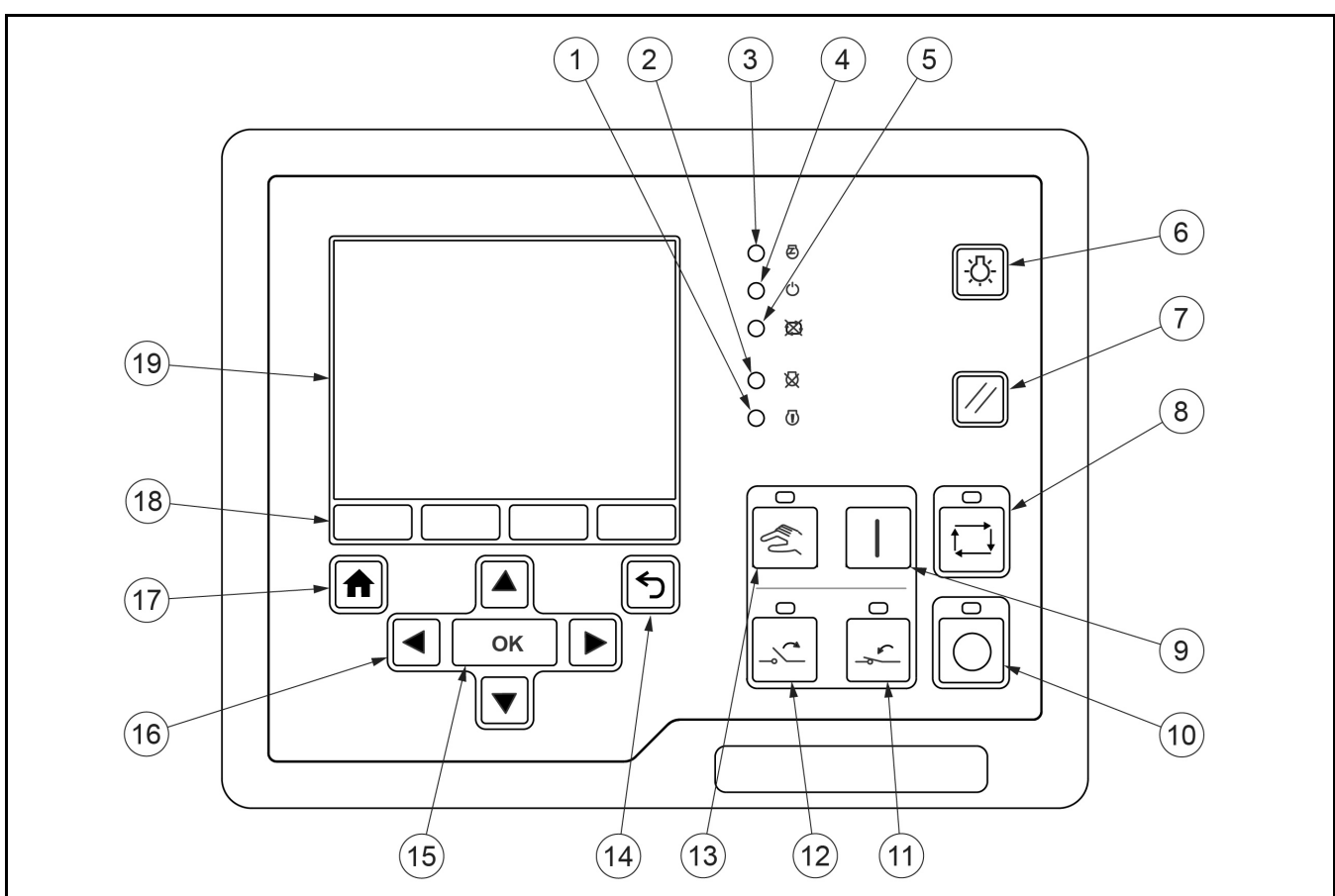

No.	Description	No.	Description
1	Indicator Lamp – Warning	11	Circuit Breaker – Closed Button
2	Indicator Lamp – Shutdown	12	Circuit Breaker – Open Button
3	Indicator Lamp – Genset Running	13	Manual Button
4	Indicator Lamp – Remote Start	14	Back/Previous Menu Button (or Clear)*
5	Indicator Lamp – Not in Auto	15	Item Select Button (OK)
6	Lamp Test Button	16	Menu Navigation Buttons (Up, Down, Left, Right)
7	Reset Button	17	Home Button
8	Auto Mode Button	18	Menu Select Buttons (Used with Graphical Display)
9	Start Button	19	Graphical Display
10	Stop Button		

FIGURE 13. OPERATOR PANEL

* Operator Panels manufactured before 2025 will have a C button instead of the back button, text labels, and buttons with text descriptors. This change does not affect operation.

4.2.1 Selection Buttons

Four momentary buttons are used to navigate and change the selection in the graphical display:

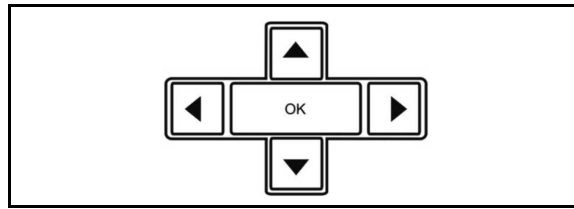

FIGURE 14. SELECTION BUTTONS

Press the **OK** button to select the item that is currently highlighted in the graphical display:

Item	Results of Pressing OK
Menu	Opens the sub-menu or screen
Parameter	Allows adjustment of the parameter (if possible) or prompts for a password
Adjusted Value	Saves the change
Action	The graphical display runs the action or prompts for a password

4.2.2 Default Settings

The operator panel can display SAE or Metric units of measurement and should be set during the initial setup of the generator set. Only trained and experienced personnel are allowed to change the default setting. Contact your authorized distributor.

4.2.3 Lamp Indicators

[Figure 13 on page 40](#) shows the front panel of the Operator Panel with the five lamp indicators.

4.2.3.1 Warning

This amber lamp is lit whenever the control detects a Warning condition. This lamp is automatically shut off when the Warning condition no longer exists.

4.2.3.2 Shutdown Status

This red lamp is lit when the control detects a Shutdown condition. The generator set cannot be started when this lamp is on. After the condition has been corrected, the lamp can be reset by first pressing the **Stop** button and then the **Reset** button.

4.2.3.3 Not in Auto

This red lamp is lit when the control is not in Auto.

4.2.3.4 Remote Start

This green lamp indicates the control is receiving a Remote Run signal. The Remote Run signal has no effect unless the generator set is in Auto.

4.2.3.5 Generator Set Running Lamp

The green lamp is lit when the generator set is running at, or near, rated speed and voltage. This is not lit while the generator set is warming up or cooling down.

4.2.4 Lamp (LED) Test Button

Press this button to test the lamps (LEDs). All of the lamps should turn on for five seconds.

Press and hold this for three seconds to turn on or off (to toggle) an external panel lamp.

4.2.5 Reset Button

Press this to reset any active faults.

If the condition(s) that caused an existing shutdown fault still exists, the generator set generates the fault again.

If the condition(s) that caused an existing warning fault still exists, the generator set generates the fault again, but the operator panel stops displaying it in the graphical display.

4.2.6 CB Open Button

The Circuit Breaker Open button is used for electrically operated circuit breakers in Manual mode only. When pressed, it enables the generator set circuit breaker to open and disconnect from the load.

4.2.7 CB Closed Button

The Circuit Breaker Closed button is used for electrically operated circuit breakers in Manual mode only. When pressed it enables the generator set circuit breaker to close when the set is up to speed and voltage and therefore, ready to accept the load.

NOTICE

This button has no effect unless the bus is dead, or the generator set is synchronized with the other source.

4.2.8 Graphical Display and Buttons

[Figure 15 on page 43](#) shows the graphical display and the relevant menu selection buttons.

The graphical display is used to view menus of the menu-driven operating system. System messages (communication, event, and fault) are also shown on the display.

Four momentary soft-key buttons (item 5) are used to change menus, or pages within each screen. These selection buttons are active when any text or the up and down triangles (▲ and ▼ in Section 4) are displayed in the graphical display. Some sub-menus do not include any active buttons.

Use the graphical display to view event/fault information, status, screens, and parameters.

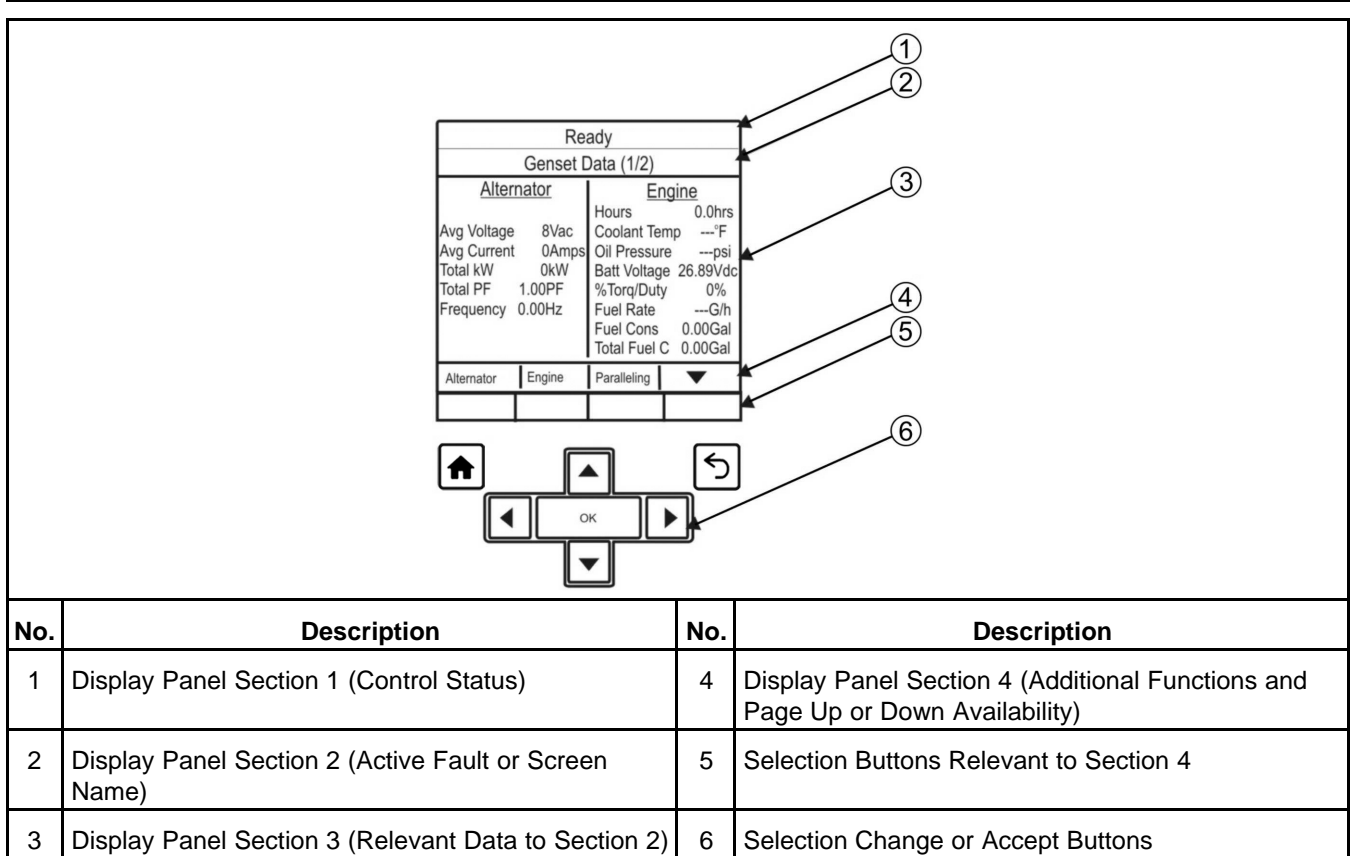

FIGURE 15. GRAPHICAL DISPLAY WITH TYPICAL SCREENSHOT

4.2.8.1 Section 1 - Control Status

Section 1 displays the status of the controller.

TABLE 3. CONTROL STATUS

Status	Description
Ready	This is the default state. The controller is ready to start the generator set, or it has started one of the start sequences but has not started the engine yet.
Starting	The controller is starting the engine in one of the start sequences, and the engine speed is greater than zero.
Idle Warmup	The controller is raising the engine speed to idle speed, or the engine is running at idle speed in one of the start sequences.
Rated Freq and Voltage	The controller is raising the engine speed to rated speed; the generator set is running at rated speed and voltage; or the controller has started one of the stop sequences but has not started reducing the engine speed yet.
Idle Cooldown	The controller is reducing the engine speed to idle speed, or the engine is running at idle speed in one of the stop sequences.
Stopping	The controller is stopping the engine, and the engine speed is still greater than zero.
Emergency Stop	There is an active shutdown fault.
Setup Mode	The controller is in Setup mode.

Status	Description
Wait to Powerdown	The controller is ready to enter Powerdown mode, but another device is sending a System Wakeup signal.
Off	The controller is in the process of entering power-down mode. The controller is performing some last-second checks.
Demo Mode	The controller is running a demonstration. Every screen is available in the demonstration, and any changes you make in the demonstration will have no effect on the controller. To end the demonstration, the operator panel must be turned off.

4.2.8.2 Section 2 - Active Fault or Screen Name

Section 2 displays the screen name and information about the last active shutdown fault. If there are no active shutdown faults, it displays the last active warning fault.

If there is an active fault, the operator panel displays the following information about it:

- Fault type
- Event/fault code
- Name of the controller that detected the fault (e.g., the engine ECM unit); this is blank if the controller detected the fault
- Fault name

If you press the **Reset** button, the operator panel stops displaying active warning faults, even if the condition(s) that caused the fault(s) has not been corrected. However, the Warning LED remains on.

The operator panel always displays any active shutdown faults, even if the **Reset** button is pressed.

TABLE 4. ACTIVE FAULT TYPES

Fault Type	Description
Warning	This is a warning fault. (See the Troubleshooting section.)
Derate	This is a derate fault. (See the Troubleshooting section.)
Shutdown	This is a shutdown fault that initiates a Shutdown Without Cooldown sequence. (See the Troubleshooting section.)
Shutdown with Cooldown	This is a shutdown fault that initiates a Shutdown With Cooldown sequence.

4.2.8.3 Section 3 - Interactive Screen or Menu

Section 3 shows information relevant to Section 2. You can view the operating values for the generator set, navigate through screens and adjust parameters (if permitted).

The default screen is the Genset Data screen.

The following table explains how the operator panel displays when the value of a specific parameter is missing, unexpected, or outside the range allowed for the parameter.

TABLE 5. PARAMETER VALUES THAT ARE MISSING, UNEXPECTED, OR OUTSIDE THE RANGE ALLOWED

Operator Panel	Description
NWF	Network Failure - There is a PCCNet network failure or a CAN (ECM) failure.

Operator Panel	Description
OORL	Out Of Range Low - The value is less than the lowest allowed value for this parameter.
OORH	Out Of Range High - This value is greater than the highest allowed value for this parameter.
-- -- --	This value is not applicable.

4.2.8.4 Section 4 - Additional Functions Indicators

Section 4 indicates if additional information or further sub-menus are available by up or down arrows (▲ and ▼). If that particular page or menu has no additional information, then no arrow will be visible at this time.

For example if the graphical display is not big enough to display the screen at one time an up and/or down arrow (▲ and ▼) will be visible. Press the appropriate selection button beneath the graphical display to look at the previous or next page of information in that screen.

4.2.8.5 Menu Navigation Buttons

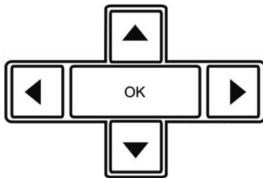

Four momentary buttons are used to navigate and change the selection in the graphical display.

Press the **OK** button to select the item that is currently highlighted in the graphical display:

- If the selected item is a menu item, this opens the sub-menu or screen.
- If the selected item is a parameter, this lets you adjust the parameter (if possible) or prompts you for a password.
- If the selected item is a value you have just adjusted, this saves the change.
- If the selected item is an action, the graphical display runs the action or prompts you for a password.

4.3 Operator Panel - Initial Operator Menu

[Figure 16 on page 47](#) shows the initial menu which is displayed over two pages. Use the soft-key buttons below the up and down arrows (▲ and ▼) to toggle between the two pages.

Use the soft-key buttons below Genset, Alternator, or Engine to short-cut to those menus.

Pressing the **Home** button  from any screen will return the display to the main menu screens.

4.3.1 Initial Menu Data

This menu displays the information available through the menus.

TABLE 6. INITIAL MENU DATA

Name	Description
History/About	Use this screen to view historical information about your generator set.
Faults:	If there are no active Faults, these screens will not be available.

Name	Description
Active Shutdowns	Use this screen to view active Shutdown faults.
Active Warning	Use this screen to view active Warning faults.
History	Use this screen to view faults that have been cleared.
Paralleling Status	Use this screen to view the bus, circuit breakers, and paralleling states.
Genset Data	Use this screen to view the status of the generator set.
Alternator Data	Use this screen to view the status of the alternator.
Engine Data	Use this screen to view the status of the engine.
Advanced Status:	
Genset	Use this screen to view power, energy, phase difference, and other detailed generator set information.
Controller	Use this screen to view sequences of operation, configurable inputs and outputs, and other detailed controller information.
Engine	Use this screen to view pressures, voltages, temperatures, and other detailed engine information.
Help	Use this screen to obtain more information regarding the operator panel.
Setup Menus:	
Adjust	The use of these screens is restricted to authorized personnel only.
Genset Setup	
Paralleling Setup	
OEM Setup	
PCCnet Setup	
Modbus Setup	
Display Options	
Clock Setup	
Configurable IO	
Calibration	
Save/Reserve	

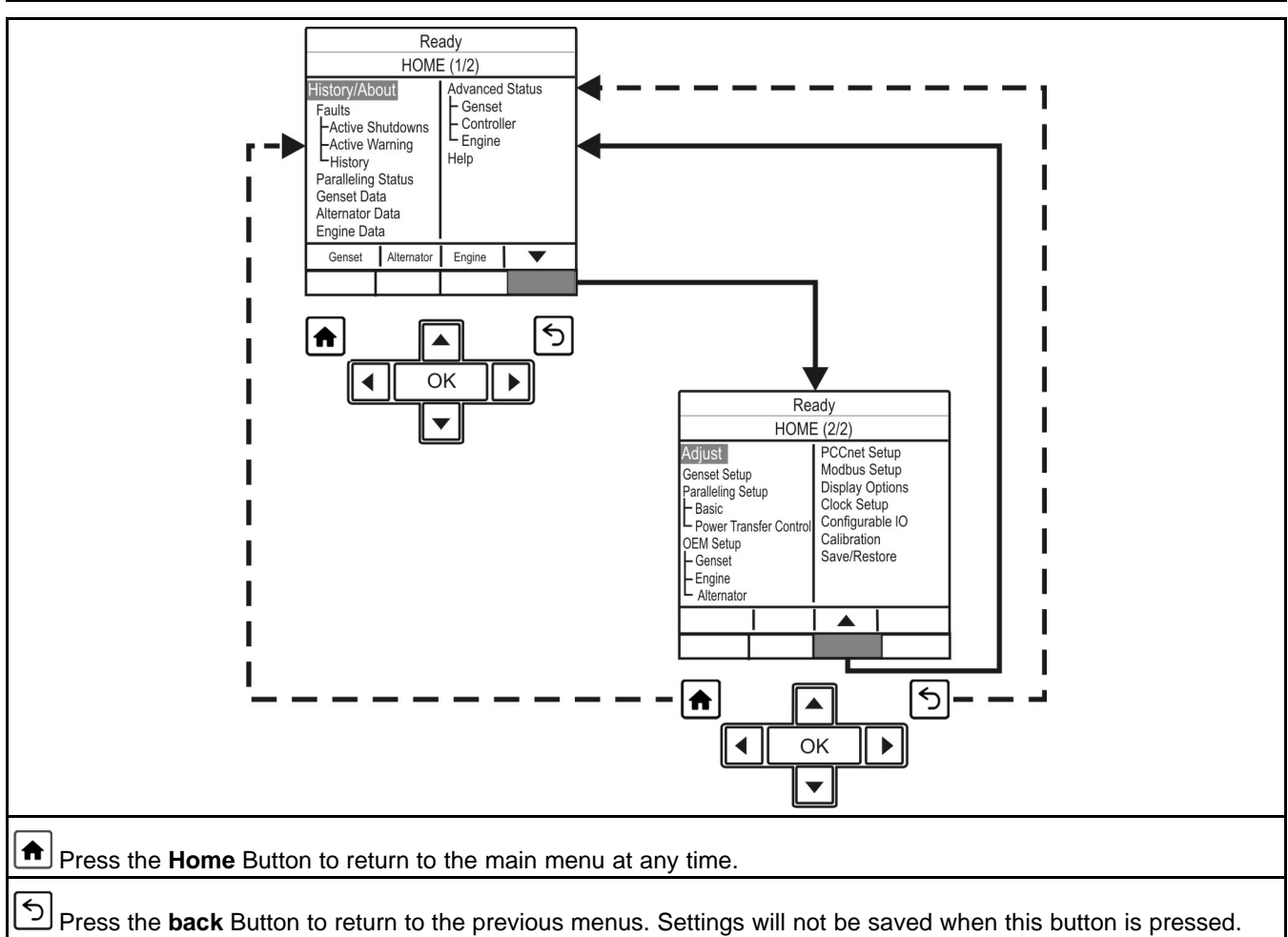
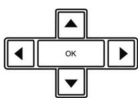

FIGURE 16. INITIAL OPERATOR MENU

4.4 Operator Panel - Generator Set Data Operator Menu

Figure 17 shows a block representation of a typical Genset Data menu. To navigate from the Home menu (HOME [1/2]), press the soft-key button below the function button indicating Genset. This will take you directly to the Genset menu.



The Genset Data menu is displayed on two pages. Use the two soft-key buttons below the up and down arrows (▲ and ▼) to toggle between the pages.

4.4.1 Generator Set Data

Use this menu to look at the status of the generator set.

TABLE 7. GENERATOR SET DATA

PARAMETER	DESCRIPTION
Alternator	
Genset LL Average Voltage	Generator Set Line to Line average voltage
Genset Average Current	Generator Set average current
Genset Total kW	Generator Set total kW
Genset Total Power Factor	Generator Set L1 power factor
Genset Frequency	Generator Set frequency
Engine	
Engine Running Time	Total engine run time
Coolant Temperature	Monitor point for the Coolant Temperature
Oil Pressure	Monitor point for the Oil Pressure Allowed values: 0–145 PSI.
Battery Voltage	Battery voltage value.
Percent Engine Torque/Duty Cycle	Monitor point for the percent engine torque output and the governor percent duty cycle output when used with the HM ECM Allowed values: –125–125%.
Fuel Rate	Monitor point for the Fuel Rate Allowed values: 0–845 liters/hr (223.2 gal/hr)
Fuel Consumption Since Reset	Fuel consumption since last reset.
Total Fuel Consumption	Total fuel consumption since start of engine.
Genset Application	
Genset Application kW rating	The Generator Set KW rating.
Genset Application kVA rating	The Generator Set KVA rating.
Genset Application Nominal Current	The value of the Generator Set application nominal current.
Genset Standby	
Genset Standby kW rating	KW rating for the Generator Set in Standby configuration.
Genset Standby kVA rating	KVA rating for the Generator Set in Standby configuration.
Genset Standby Nominal Current	The value of the Generator Set standby nominal current.

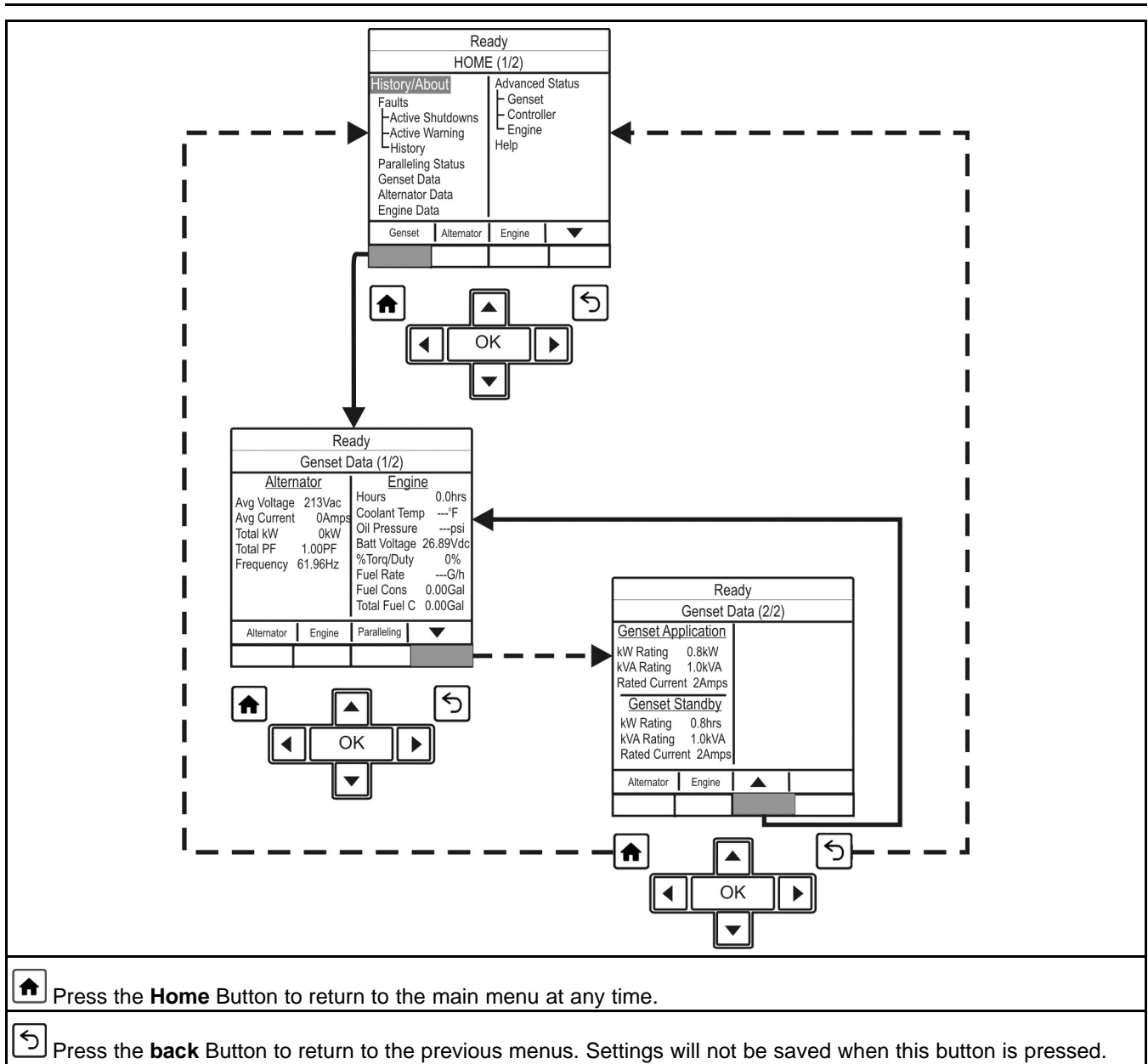

FIGURE 17. GENERATOR SET DATA MENU - TYPICAL DATA

4.5 Operator Panel - Engine Data Operator Menu

Figure 18 on page 51 shows a block representation of a typical Engine Data menu. To navigate from the Home menu (HOME [1/2]), press the soft-key button below the function button indicating Engine. This will take you directly to the Engine menu.

The Engine Data menu is displayed on one page.

4.5.1 Engine Data

Use this menu to look at the status of the engine.

TABLE 8. ENGINE DATA (LBNG GENSET ENABLE IS SET TO DISABLE)

Name	Description
Oil Pressure	Monitor point for the Oil Pressure Allowed values: 0–145 PSI.
Boost Pressure	Monitor point for the Boost Absolute Pressure Allowed values: 0–148 PSI.
Coolant Pressure	Monitor point for the Coolant Pressure Allowed values: 0–145 PSI.
Fuel Supply Pressure	Monitor point for the Fuel Supply Pressure Allowed values: 0–145 PSI.
Fuel Outlet Pressure	Monitor point for the Fuel Outlet Pressure Allowed values: 0–36404 PSI.
Crankcase Pressure	Monitor point for the Crankcase Pressure Allowed values: –35.67–38 PSI.
Barometric Absolute Pressure	Monitor point for the Barometric Absolute Pressure Allowed values: 0–37 PSI.
Coolant Temperature	Monitor point for the Coolant Temperature
Oil Temperature	Monitor point for the Oil Temperature Allowed values: –40–770 °C (–40–410 °F)
Intake Manifold Temperature	Monitor point for the Intake Manifold Temperature Allowed values: –40–770 °C (–40–410 °F)
Fuel Temperature	Monitor point for the Fuel Temperature Allowed values: –40–770 °C (–40–410 °F)
Aftercooler Temperature	Monitor point for the Aftercooler Temperature Allowed values: –40–770 °C (–40–410 °F)
Battery Voltage	Battery voltage value
Average Engine Speed	Monitor point for the Average Engine Speed
Engine Running Time	Total engine run time
Glow Plug Command	Output of glow plug logic Allowed values: Driver Off, Driver On
Oil Pressure Switch Status	Low or Not Low. Allowed values: Not Low, Low

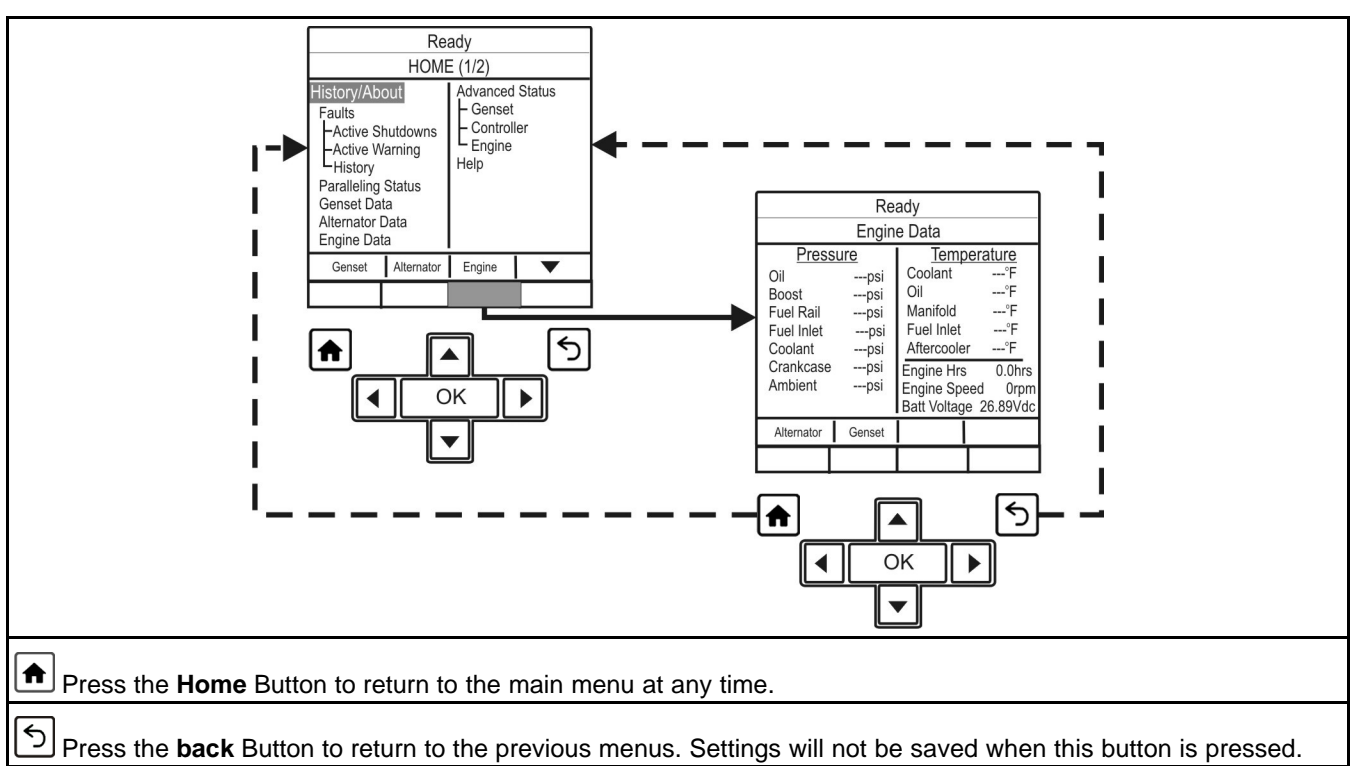

FIGURE 18. ENGINE DATA MENU - TYPICAL DATA

4.5.2 History/About Menu

[Figure 19 on page 53](#) shows a block representation of a typical History/About menu.

To navigate from the Home menu, toggle down until the History/About line of text is highlighted and press the **OK** button. This information is displayed over three pages. Use the two soft-key buttons below the up and down arrows (▲ and ▼) to toggle between the pages.

This screen displays the historical information about the generator set.

TABLE 9. HISTORY/ABOUT

Name	Description
Start Attempts (Starts)	Total number of start attempts Allowed values: 0–65535
Total Number of Runs (Runs)	Total number of generator set runs Allowed values: 0–65535
Engine Running Time (Engine Hours)	Total engine run time in hours
Controller On Time (Control Hours)	Controller ON time in hours, Upper limit is 136 years Allowed values: 0–4294967291 hours
Generator Set Total Net (Kw Hours)	Generator set total net kWh accumulation Allowed values: –2147483648–2147483643 kWh
Generator Set Model Number (Gen Mod #)	Number identifying the model of this generator set (Password level: 2)

Name	Description
Generator Set Serial Number (Gen Ser #)	Serial number identifying this generator set
Generator Set Nominal Voltage (Nominal Voltage)	Generator set nominal line-line voltage (Password level: 1) Allowed values: 1–45000 VAC (Default: 1 VAC)
Generator Set Delta/Wye Connection (Wye/Delta)	Delta or Wye for generator set connection (Password level: 1) Allowed values: Delta, Wye (Default: Wye)
Application Rating Select (Rating Select)	Selects generator set's standby/prime/base application rating (Password level: 1) Allowed values: Standby, Prime, Base (Default: Standby)
Controller Device Type (Contr Type)	Used by the PC Tool Allowed values: PCC3300, PCC3300 with Masterless Load Demand (MLD)
Calibration Part Number (Calib Part)	The unique calibration part number loaded into this control (Password level: 3)
Calibration Revision Date (Calib Date)	The revision date of the calibration part number loaded into this control (Password level: 3)
Firmware Version Number (Contr H/ ver)	Version of S/W loaded into this control, obtained from PCC Filename

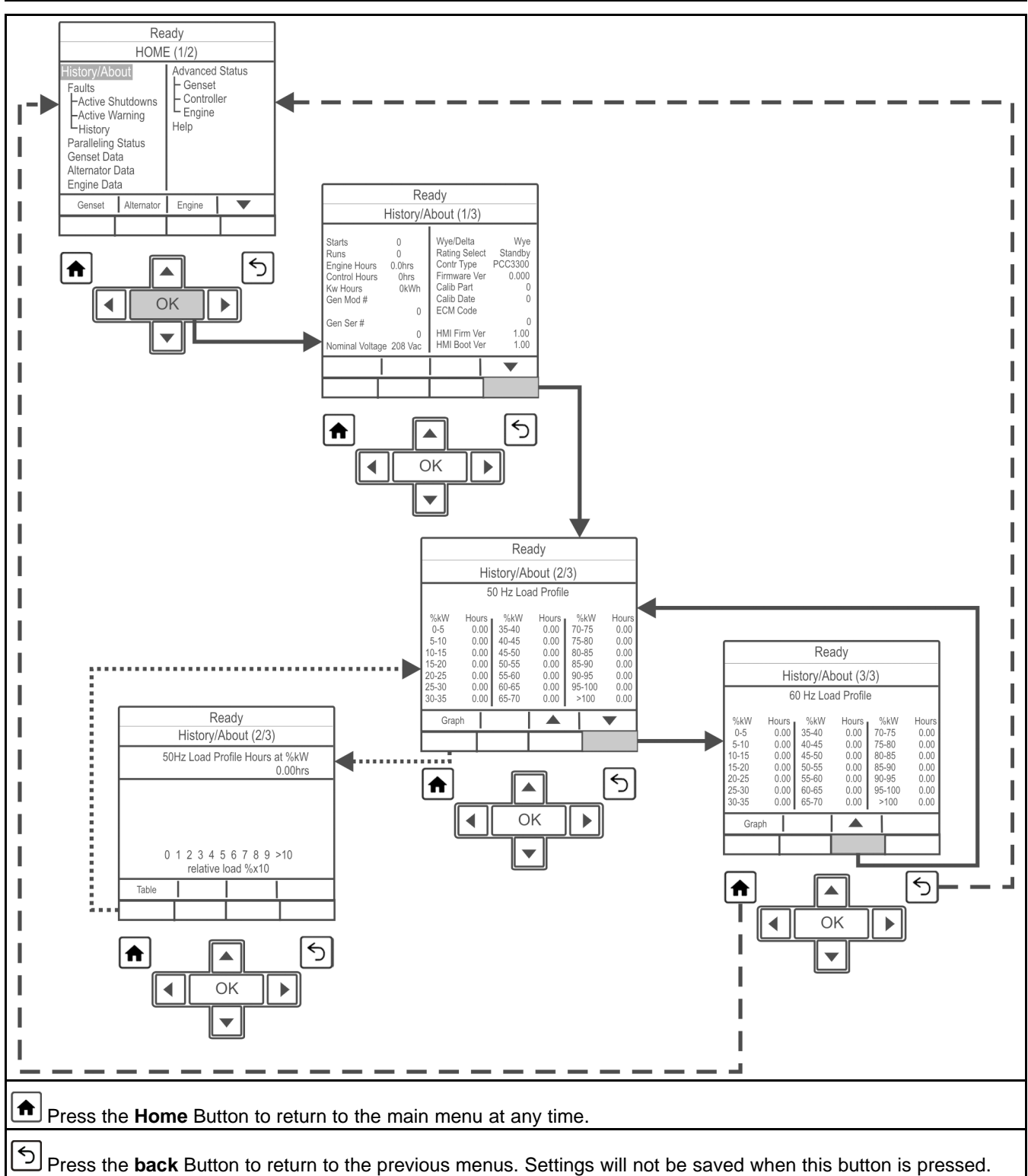

FIGURE 19. HISTORY/ABOUT MENU - TYPICAL DATA

4.6 Operator Panel - Alternator Data Operator Menu

[Figure 20 on page 56](#) shows a block representation of a typical Alternator Data menu. To navigate from the Home menu (HOME [1/2]), press the soft-key button below the function button indicating Alternator. This will take you directly to the Alternator menu.

The Alternator Data menu is displayed on one page.

4.6.1 Alternator Data

Use this menu to look at the status of the alternator. This menu displays line-to-line voltage, line-to-neutral voltage, current, and generator set power (in kVA). Some values are not available, dependent on the number of phases (one or three) and whether or not the application has current transformers.

TABLE 10. ALTERNATOR DATA

Parameter	Description
Genset L1L2 Voltage	Generator Set L1L2 voltage
Genset L1N Voltage	Generator Set L1N voltage
Genset L1 Current	Monitors the genset L1 current value
Genset L1 kW	Generator Set L1 kW
Genset L1 KVA	Generator Set L1 kVA
Genset L1 Power Factor	Generator Set L2 power factor Allowed values: -1.28-1.27 PF
Genset L2L3 Voltage	Generator Set L2L3 voltage
Genset L2N Voltage	Generator Set L2N voltage
Genset L2 Current	Generator Set L2 current
Genset L2 kW	Generator Set L2 kW Allowed values: -32768-32762 kW
Genset L2 KVA	Generator Set L2 kVA
Genset L2 Power Factor	Generator Set L2 power factor Allowed values: -1.28-1.27 PF
Genset L3L1 Voltage	Generator Set L3L1 voltage
Genset L3N Voltage	Generator Set L3N voltage
Genset L3 Current	Generator Set L3 current
Genset L3 kW	Generator Set L3 kW Allowed values: -32768-32762 kW
Genset L3 KVA	Generator Set L3 kVA Allowed values: 0-4294967.29 kVA
Genset L3 Power Factor	Generator Set L3 power factor Allowed values: -1.28-1.22 PF
Genset Total kW	Generator Set total kW
Genset Total KVA	Generator Set total kVA

Parameter	Description
Genset Total Power Factor	Generator Set L1 power factor
Genset Frequency	Generator Set frequency
AVR PWM Command	The AVR PWM software command. Linear relationship between counts and % duty cycle with 10000 counts=100% duty cycle
Genset Neutral Current	Generator Set neutral current This is not displayed if the neutral current is not available.
Ground Current	Ground current
Alternator Temperatures	
Non-Drive End Bearing Temperature (Aux101)	Monitor point for the Non-Drive End Bearing Temp input from the I/O Module. Allowed values: -117929-117995 °C (65534-65535 °F)
Drive End Bearing Temperature (Aux101)	Monitor point for the Drive End Bearing Temp input from the I/O Module. Allowed values: -58949-59004 °C (-32767-32762 °F)
Alternator Temperature 1 (Aux101)	Monitor point for the Alternator Temp 1 input from the Aux 101 I/O Module. Allowed values: -58949-59004 °C (-32767-32762 °F)
Alternator Temperature 2 (Aux101)	Monitor point for the Alternator Temp 2 input from the Aux 101 I/O Module. Allowed values: -58949-59004 °C (-32767-32762 °F)
Alternator Temperature 3 (Aux101)	Monitor point for the Alternator Temp 3 input from the Aux 101 I/O Module. Allowed values: -58949-59004 °C (-32767-32762 °F)

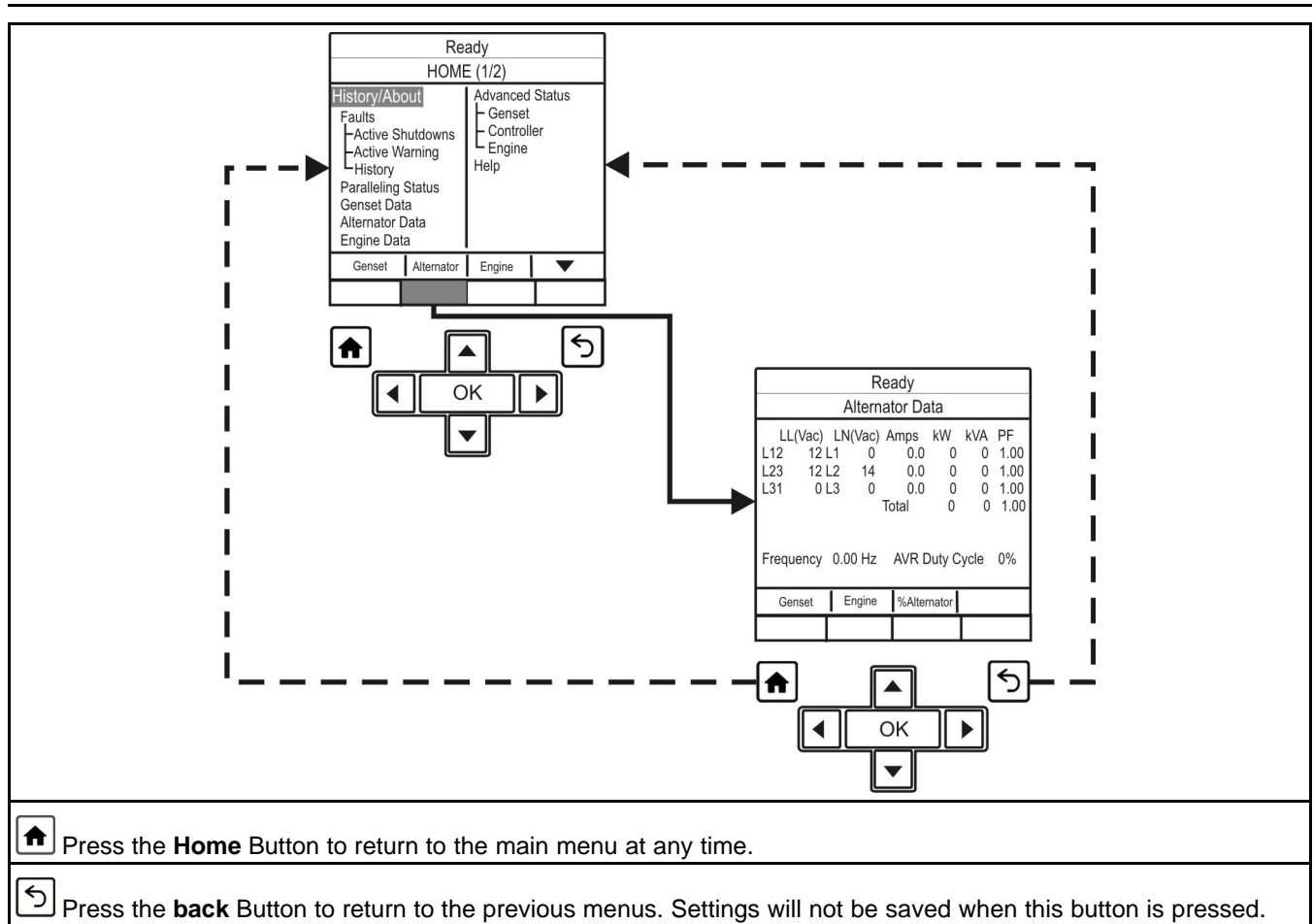

FIGURE 20. ALTERNATOR DATA MENU - TYPICAL DATA

4.7 Operator Panel - Faults and Warnings Menu

The Faults and Warning menu is divided into three main sub-sections; Shutdown Faults (Active Shutdowns); Warning Faults (Active Warnings); and Faults History (showing up to thirty-two faults that have been cleared).

4.7.1 Fault Menu

Figure 21 shows a block representation of a typical Fault menu.

To navigate from the Home menu, select the Fault menu from the Home screen.

The fault menu home screen displays, which is divided into three main sub-sections: Active Faults (Active Shutdowns), Active Warnings, and Faults History. The Faults History screen shows up to 32 faults that have been cleared.

Use the 2 soft-key buttons below the up and down arrows (▲ and ▼) to toggle between the pages.

TABLE 11. ACTIVE SHUTDOWN FAULTS

Name	Description
Index	This is the index number of the fault.

Name	Description
Fault	This is the fault code.
SA	Source Address This is the controller that identified the fault. It is blank if the PCC identified the fault.
Eng Hrs	This is how many hours the engine had run (not necessarily continuously) when the fault was generated.
YY/MM/DD	This is the date the fault was generated.
HH:MM:SS	This is the time the fault was generated.
Response	This is the type of fault that was generated.
	The name of the fault appears below the rest of the information.

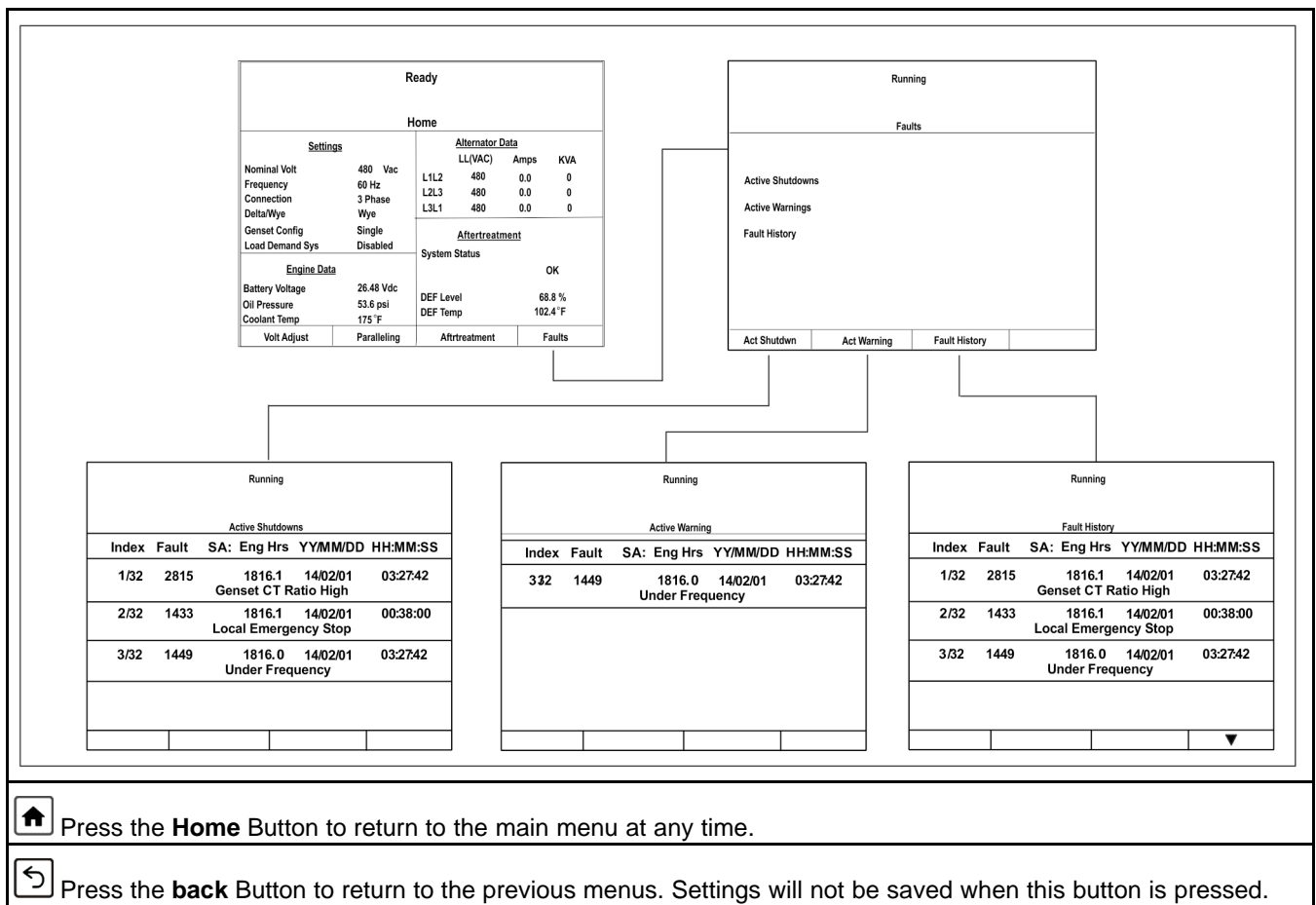

FIGURE 21. FAULTS MENU

4.7.2 Fault Messages

Ready Fault History				
Index	Fault SA:	Eng Hrs	DD/MM/YY	HH:MM:SS
427 1/2		0.0	15/06 00	18:50:41 CAN Data Link Degraded
1689 2/2		0.0	00/00/00	00:00:00 Reset Real Time Clock
Warnings Shutdowns				

FIGURE 22. FAULT MESSAGE DISPLAY SCREEN

A Fault message is an indicator of a Warning or Shutdown condition. It includes the fault number, and a short description. It also includes where the fault occurred if the generator set control did not detect the fault and is simply reporting the fault. For a list of the fault codes, types, and message displayed, see [Chapter 8 on page 159](#).

Active and acknowledged faults may be viewed in the Faults menu.

4.7.3 Fault Acknowledgement

Shutdown faults must be acknowledged after the fault has been corrected. If in Auto or Manual mode, the control must be set to Stop mode (Off). Faults are cleared from the control panel display by pressing the **Reset** button.

Faults are re-announced if they are detected again after being acknowledged. See the Reset Button section.

NOTICE

Faults may also be acknowledged when in Auto mode and the Remote Start command is removed. Contact your authorized distributor for this option.

4.7.4 Warning Fault Menu

[Figure 23](#) shows a block representation of a typical Warning Fault menu.

To navigate from the Home menu, toggle down until the Faults - Warning Fault line of text is highlighted and press the **OK** button. This will then display information regarding the current fault. Use the 2 soft-key buttons below the up and down arrows (▲ and ▼) to toggle between the pages.

This menu displays up to 32 faults. The same event/fault code may appear multiple times if detected by different sources.

TABLE 12. ACTIVE WARNING FAULTS

Name	Description
Index	This is the index number of the fault.
Fault	This is the Fault code.
SA	Source Address This is the controller that identified the fault. It is blank if the PCC identified the fault.
Eng Hrs	This is how many hours the engine had run (not necessarily continuously) when the fault was generated.
HH:MM:SS	This is the time the fault was generated.
Response	This is the type of fault that was generated.
	The name of the fault appears below the rest of the information.

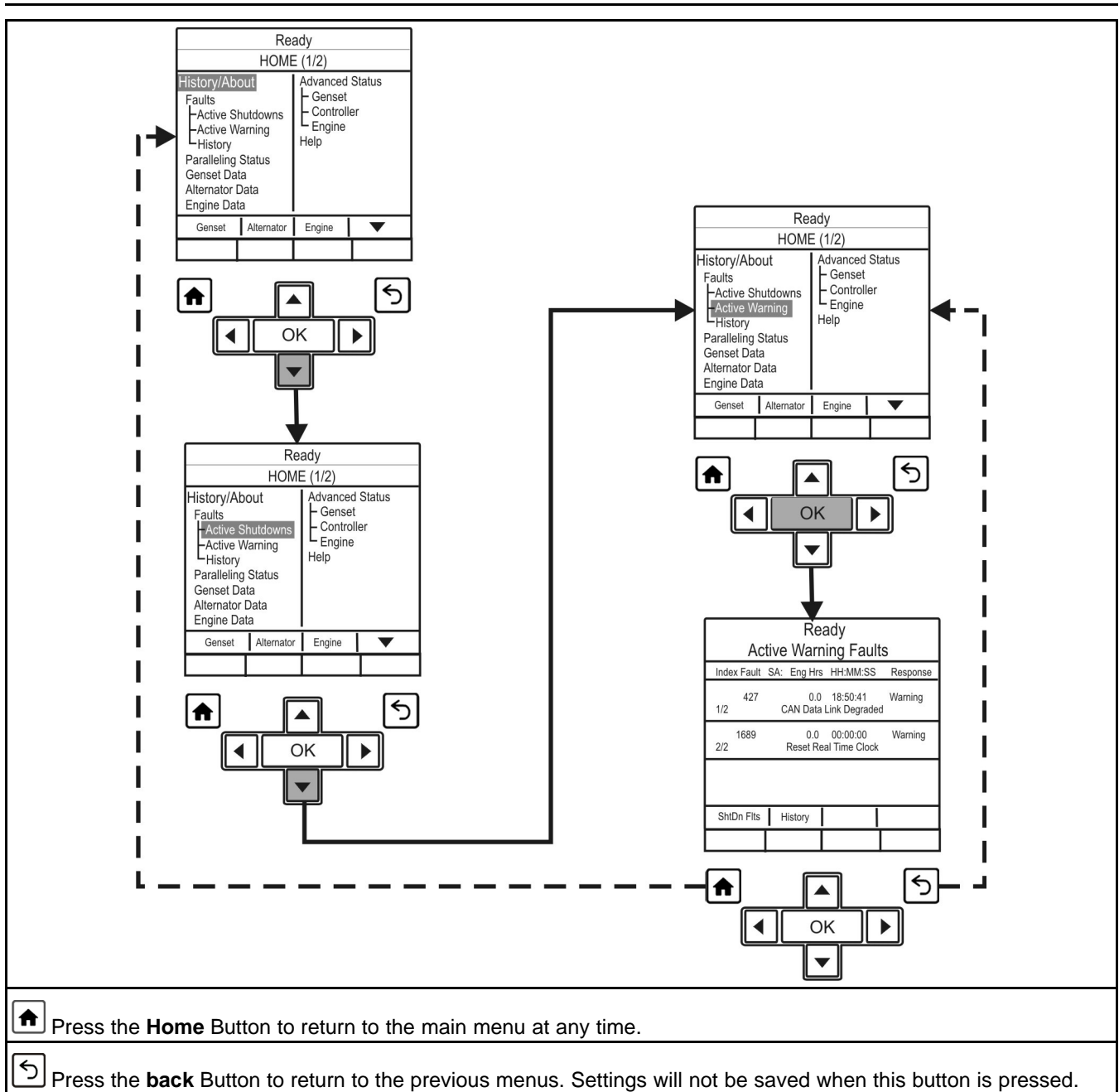

FIGURE 23. WARNING FAULT MENU - TYPICAL DATA

4.7.5 Faults History Data Operator Menu

Figure 24 on page 62 shows a block representation of a typical Fault History menu.

To navigate from the Home menu, toggle down until the Faults -History line of text is highlighted and press the **OK** button. This will then display information regarding the fault(s) history. Use the 2 soft-key buttons below the up and down arrows (▲ and ▼) to toggle between the pages.

This menu displays up to 32 faults. The same event/fault code may appear multiple times if detected by different sources.

TABLE 13. FAULTS HISTORY DATA OPERATOR MENU

Name	Description
Index	This is the index number of the fault.
Fault	This is the Fault code.
SA	This is the controller that identified the fault. It is blank if the PowerCommand® 3.3 control identified the fault.
Engine Hrs	This is how many hours the engine had run (not necessarily continuously) when the fault was generated.
MM/DD/YY	This is the date the fault was generated.
HH/MM/SS	This is the time the fault was generated.
	The name of the fault appears below the rest of the information.

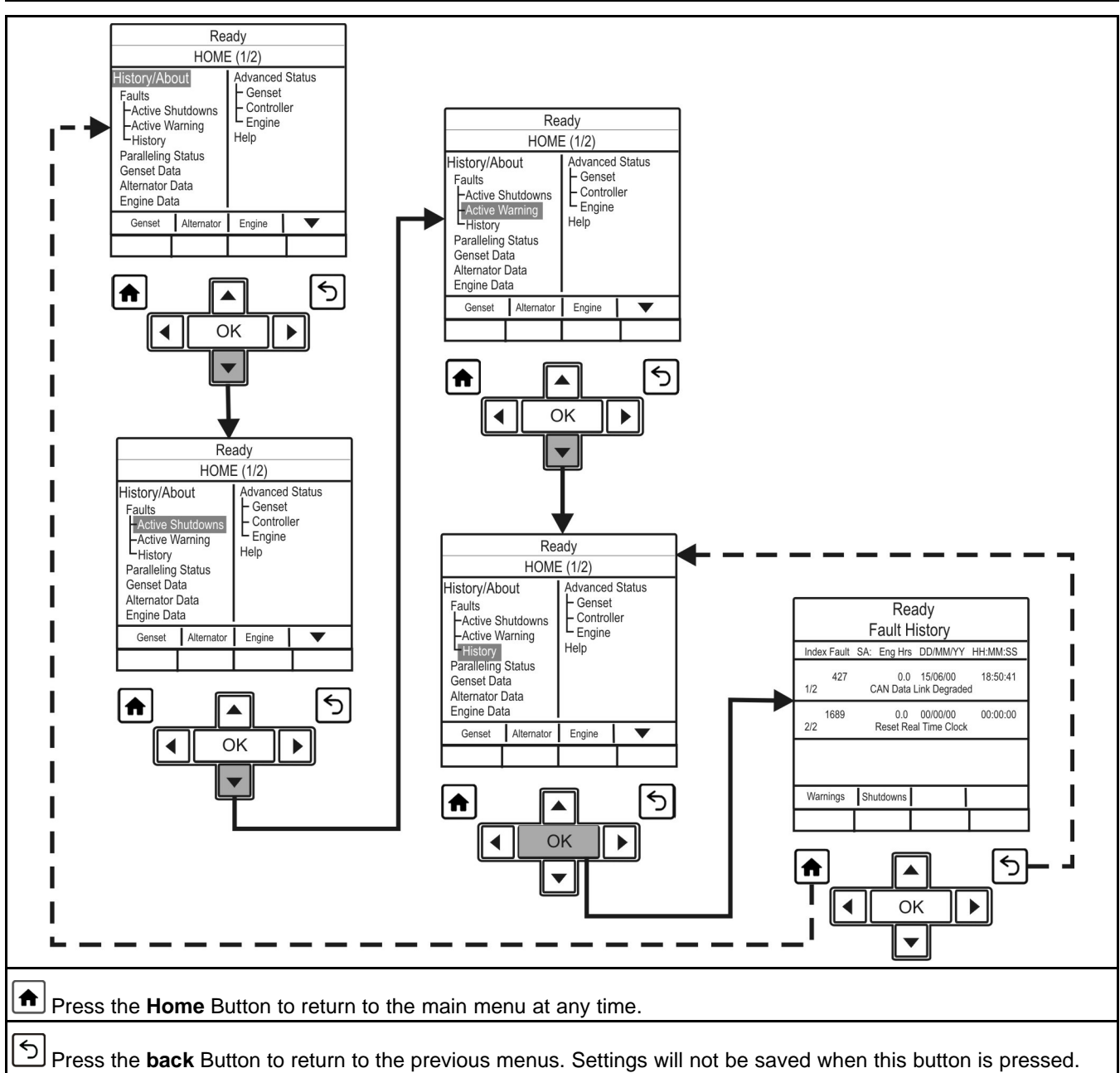

FIGURE 24. HISTORY FAULT MENU - TYPICAL DATA

4.8 Operator Panel - Adjust Menu

Figure 25 on page 64 shows a block representation of a typical Adjust menu. To navigate from the Home menu (HOME (1/2)), press the soft-key button below the down arrow in the display window. This will show the second page of the Home menu (HOME (2/2)). With the Adjust line of text highlighted, press the **OK** button to display the information.

The Adjust menu is displayed on one page.

NOTICE

Should any of these settings require amendment or change, please contact your authorized service center.

NOTICE

You cannot adjust Frequency Adjust or Voltage Adjust if Paralleling Speed Control Mode is set to Synchronize, Load Share, or Load Govern.

TABLE 14. OPERATOR PANEL - ADJUST MENU

Name	Description
Voltage Adjust	
Genset LL Average Voltage	Generator set Line-to-Line average voltage.
Voltage Adjust	A trim that allows the user to add/subtract an offset to the nominal voltage when calculating the voltage setpoint. Allowed values: -5-5%. Default value: 0%
Rated/Idle Sw	Allowed values: Rated, Idle. Default value: Rated.
Exer Switch	Allowed values: Inactive, Active. Default value: Inactive.
Man Warm Byp	Allowed values: Normal, Bypass Warmup.
Keyswitch	
Keyswitch Status	Allowed values: Inactive, Active.
Frequency Adjust	
Final Frequency Reference	The frequency scaled version of the final speed reference. Allowed values: 0-100 Hz.
Frequency Adjust	A method of adding in a frequency offset to the base frequency subject to high and low limit calibrations. Allowed values: -6-6 Hz. Default value: 0 Hz.
Avr Gain	A trim that allows the user to modify the overall gains of the AVR. Allowed values: 0.05-10. Default value: 1
Governor Gain	A trim that allows the user to modify the overall gain of the governor. Allowed values: 0.05-10. Default value: 1
Start Delay	Allowed values: 0-300 seconds. Default value: 0 seconds.
Stop Delay	Allowed values: 0-600 seconds. Default value: 0 seconds.

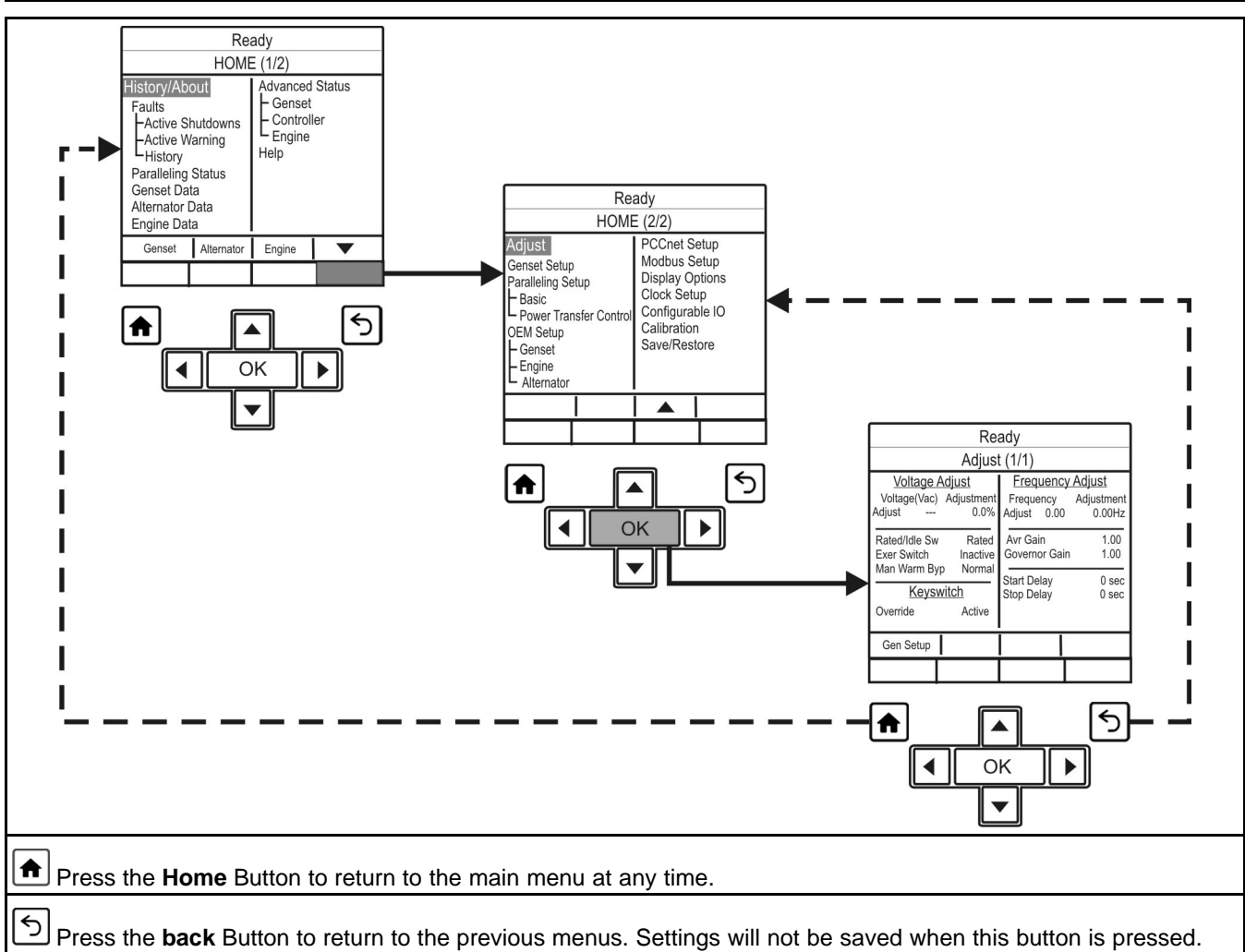

FIGURE 25. ADJUST MENU - TYPICAL DATA

4.9 Operator Panel - Genset Setup Data Operator Menu

Figure 26 on page 65 shows block representations of the Genset Setup Data menu.

Page down to the second page of the Home menu (using the 2 soft-key buttons below the up and down arrows [▲ and ▼]). See Section 4.3 on page 45.

In the HOME (2/2) menu, using the up and down arrows, toggle down again until the Genset Setup text is highlighted.

With the Genset Setup line of text highlighted, press the **OK** button. This will display the Setup Menu.

Use the 2 soft-key buttons below the up and down arrows [▲ and ▼] to page through the 5 pages of the Setup data.

NOTICE

Should any of these settings require amendment or change, please contact your authorized service center.

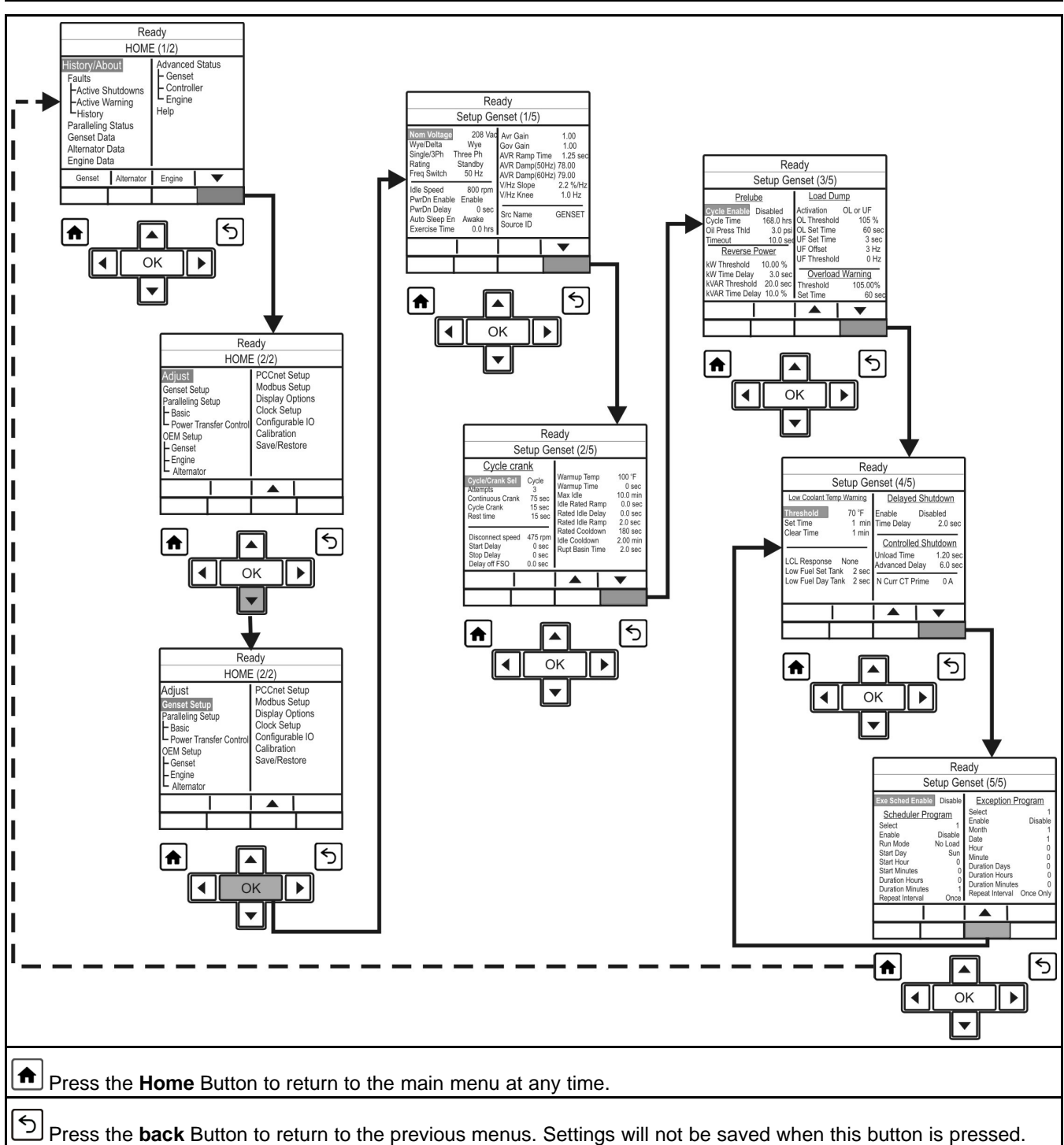

FIGURE 26. SETUP DATA MENU - TYPICAL DATA

4.10 Operator Panel - Paralleling Status Menu

Figure 27 on page 72 and Figure 28 on page 73 show block representations of a typical Paralleling Status menu. This screen varies according to the application type. See Section 5.9.3.

In the HOME (1/2) menu, using the up and down arrows, toggle down until the Paralleling Status text is highlighted.

With the Paralleling Status line of text highlighted, press the **OK** button. This will then display the Paralleling Status Menu (if the generator set application type is not Standalone).

Use the two soft-key buttons below the up and down arrows [**▲** and **▼**] to page through the six pages of the Paralleling Status menu.

TABLE 15. PARALLELING STATUS

Parameter	Description
ES State	Internal paralleling status variable Allowed values: Standby, Dead Bus, Synchronize, Load Share, Load Govern
Genset LL Average Voltage	Generator set line-to-line average voltage
Genset Frequency	Generator set frequency
Genset Total kW	Generator set total kW
Genset Total kVAR	Generator set total kVAR
Genset Total Power Factor	Generator set L1 power factor
Genset CB Position Status	Indicates generator set breaker position Allowed values: Open, Closed, Not Available
Phase Match Error	Phase error signal for the synchronizer control algorithm
Load Demand Stop Command	Indicates status of the final load demand stop command to generator set start stop control function Allowed values: Don't Stop, Stop
Genset Bus LL Average Voltage	Generator set bus line-to-line average voltage
Genset Bus Frequency	Generator set bus line frequency
Genset Bus Total kW	Generator set bus total kW
Genset Bus Total kVAR	Generator set bus total kVAR
Genset Bus Total Power Factor	Generator set bus total power factor
Synchronizer Status	Indicates whether synchronizer is on or off Allowed values: Synchronizer Off, Synchronizer On
Bus Status	Indicates status of the bus Allowed values: Unavailable, Dead, Live
Permissive Close Allowed	Indicates when permissive sync check conditions have been met Allowed values: Not Allowed, Allowed
Phase Matched	Sync check phase match status Allowed values: Inactive, Active
Voltage Matched	Sync check voltage match status Allowed values: Inactive, Active
Frequency Matched	Sync check frequency match status Allowed values: Inactive, Active
Phase Match Error	Phase error signal for the synchronizer control algorithm

Parameter	Description
Frequency Match Error	Frequency match error value used by frequency match PI loop
Voltage Match Error	Voltage match error value used by voltage match PI loop
Load Govern kW Target	Indicates the final target set point for generator set kW output when paralleled to utility
Load Govern kVAR Target	Indicates the final target set point for generator set kVAR output when paralleled to utility
Power Factor Setpoint	Indicates analog input power factor set point derived from kVAR analog input
Paralleling Speed Control Mode	Indicates which speed control algorithm is in effect Allowed values: Isochronous, Droop, Synchronize, Load Share, Load Govern
Paralleling Voltage Control Mode	Indicates which voltage control algorithm is in effect Allowed values: Isochronous, Droop, Synchronize, Load Share, Load Govern
Genset CB Tripped Command	Generator set CB tripped command Allowed values: Inactive, Active (Default: Inactive)
Genset CB Inhibit Command	Generator set CB inhibit command Allowed values: Inactive, Active (Default: Inactive)
Load Share %kW Error	Indicates %kW error for load sharing control algorithm
Utility CB Tripped Command	Utility CB tripped command Allowed values: Inactive, Active (Default: Inactive)
Load Share %kVAR Error	Indicates %kVAR error for load sharing control algorithm
Utility CB Inhibit Command	Utility CB inhibit command Allowed values: Inactive, Active (Default: Inactive)
Utility Current Based Breaker Position	Indicates utility breaker position based on current
Genset Bus L1L2 Voltage	Generator set bus L1L2 voltage
Genset Bus L2L3 Voltage	Generator set bus L2L3 voltage
Genset Bus L3L1 Voltage	Generator set bus L3L1 voltage
Genset Bus L1N Voltage	Generator set bus L1N voltage
Genset Bus L2N Voltage	Generator set bus L2N voltage
Genset Bus L3N Voltage	Generator set bus L3N voltage
Genset Bus L1 Current	Generator set bus L1 current Allowed values: 0~65530 amps
Genset Bus L2 Current	Generator set bus L2 current Allowed values: 0~65530 amps
Genset Bus L3 Current	Generator set bus L3 current Allowed values: 0~65530 amps
Genset Bus L1 kW	Generator set bus L1 kW Allowed values: -32768~32762 kW

Parameter	Description
Genset Bus L2 kW	Generator set bus L2 kW Allowed values: -32768~32762 kW
Genset Bus L3 kW	Generator set bus L3 kW Allowed values: -32768~32762 kW
Genset Bus Total kW	Generator set bus total kW
Genset Bus L1 kVA	Generator set bus L1 kVA
Genset Bus L2 kVA	Generator set bus L2 kVA
Genset Bus L3 kVA	Generator set bus L3 kVA
Genset Bus Total kVA	Generator set bus total kVA
Genset Bus L1 Power Factor	Generator set bus L1 power factor Allowed values: -1.28~1.22 PF
Genset Bus L2 Power Factor	Generator set bus L2 power factor Allowed values: -1.28~1.22 PF
Genset Bus L3 Power Factor	Generator set bus L3 power factor Allowed values: -1.28~1.22 PF
Genset Bus Total Power Factor	Generator set bus total power factor
Genset Bus Frequency	Generator set bus line frequency
Genset Bus L1 Positive kWh	Generator set bus L1 positive kWh accumulation Allowed values: 0~4294967290 kWh (Default: 0 kWh)
Genset Bus L2 Positive kWh	Generator set bus L2 positive kWh accumulation Allowed values: 0~4294967290 kWh (Default: 0 kWh)
Genset Bus L3 Positive kWh	Generator set bus L3 positive kWh accumulation Allowed values: 0~4294967290 kWh (Default: 0 kWh)
Genset Bus Total Positive kWh	Generator set bus total positive kWh accumulation
Genset Bus L1 Negative kWh	Generator set bus L1 negative kWh accumulation Allowed values: 0~4294967290 kWh (Default: 0 kWh)
Genset Bus L2 Negative kWh	Generator set bus L2 negative kWh accumulation Allowed values: 0~4294967290 kWh (Default: 0 kWh)
Genset Bus L3 Negative kWh	Generator set bus L3 negative kWh accumulation Allowed values: 0~4294967290 kWh (Default: 0 kWh)
Genset Bus Total Negative kWh	Generator set bus total negative kWh accumulation
Genset Bus Total Net kWh	Generator set bus total net kWh accumulation
Genset Bus L1 Positive kVARh	Generator set bus L1 positive kVARh accumulation Allowed values: 0~4294967290 kVARh (Default: 0 kVARh)
Genset Bus L2 Positive kVARh	Generator set bus L2 positive kVARh accumulation Allowed values: 0~4294967290 kVARh (Default: 0 kVARh)

Parameter	Description
Genset Bus L3 Positive kVARh	Generator set bus L3 positive kVARh accumulation Allowed values: 0~4294967290 kVARh (Default: 0 kVARh)
Genset Bus Total Positive kVARh	Generator set bus total positive kVARh accumulation
Genset Bus L1 Negative kVARh	Generator set bus L1 negative kVARh accumulation Allowed values: 0~4294967290 kVARh (Default: 0 kVARh)
Genset Bus L2 Negative kVARh	Generator set bus L2 negative kVARh accumulation Allowed values: 0~4294967290 kVARh (Default: 0 kVARh)
Genset Bus L3 Negative kVARh	Generator set bus L3 negative kVARh accumulation Allowed values: 0~4294967290 kVARh (Default: 0 kVARh)
Genset Bus Total Negative kVARh	Generator set bus total negative kVARh accumulation
Genset Bus Total Net kVARh	Generator set bus total net kVARh accumulation
Genset Bus Reset All Energy Meters Timestamp - Hour	Time stamp of when energy meters were last reset Allowed values: 0~23 (Default: 0)
Genset Bus Reset All Energy Meters Timestamp - Minute	Time stamp of when energy meters were last reset Allowed values: 0~59 (Default: 0)
Genset Bus Reset All Energy Meters Timestamp - Second	Time stamp of when energy meters were last reset Allowed values: 0~59 (Default: 0)
Genset Bus Reset All Energy Meters Timestamp - Day	Time stamp of when energy meters were last reset Allowed values: 1~31 (Default: 1)
Genset Bus Reset All Energy Meters Timestamp - Month	Time stamp of when energy meters were last reset Allowed values: 1~12 (Default: 1)
Genset Bus Reset All Energy Meters Timestamp - Year	Time stamp of when energy meters were last reset Allowed values: 0~99 (Default: 0)
Genset Bus L1 kVAR	Generator set bus L1 kVAR Allowed values: -32678~32672 kVAR
Genset Bus L2 kVAR	Generator set bus L2 kVAR Allowed values: -32768~32762 kVAR
Genset Bus L3 kVAR	Generator set bus L3 kVAR Allowed values: -32768~32762 kVAR
Genset Bus L1L2 Phase Difference	Generator set bus L1L2 voltage phase angle
Genset Bus L2L3 Phase Difference	Generator set bus L2L3 voltage phase angle
Genset Bus L3L1 Phase Difference	Generator set bus L3L1 voltage phase angle
Genset Bus L1 kVAh	Generator set bus L1 kVAh accumulation Allowed values: 0~4294967290 kVAh (Default: 0 kVAh)

Parameter	Description
Genset Bus L2 kVAh	Generator set bus L2 kVAh accumulation Allowed values: 0~4294967290 kVAh (Default: 0 kVAh)
Genset Bus L3 kVAh	Generator set bus L3 kVAh accumulation Allowed values: 0~4294967295 kVAh (Default: 0 kVAh)
Genset Bus Total kVAh	Generator set bus total kVAh accumulation
Genset Bus Phase Rotation	Generator set bus phase rotation Allowed values: L1-L2-L3, L1-L3-L2, Not Available
System Network Termination Resistor Switch Status	Indicates the status of the on-board CAN termination resistor switch (S1)
Load Demand State	Indicates the status of load demand operation PCC3300 MLD controls only
Load Demand Online Capacity	Indicates the total amount of online kW bus capacity for load demand Only generator sets which are eligible for load demand count PCC3300 MLD controls only
Load Demand Genset Bus Total kW	Indicates the total load of system network connected generator sets PCC3300 MLD controls only
Load Demand Surplus Capacity	Indicates the amount of unused online kW bus capacity (spinning reserve) PCC3300 MLD controls only
Load Demand Total Spare Capacity Requested	Indicates the total kW value of all currently active spare capacity requests in the system PCC3300 MLD controls only
Load Demand Spare Capacity Available	Indicates when the current load and spare capacity requirements are satisfied PCC3300 MLD controls only
Load Demand Next Stop Threshold (kW)	The kW load at which the next generator set will be stopped PCC3300 MLD controls only
Load Demand Next Start Threshold (kW)	The kW load at which the next generator set will be started PCC3300 MLD controls only
Load Demand Next Gen to Start	Indicates Genset ID of the next generator set to start PCC3300 MLD controls only
Load Demand Next Gen to Stop	Indicates Genset ID of the next generator set to stop PCC3300 MLD controls only
Load Demand Initial Delay Timer	Indicates the time remaining before generator sets are allowed to stop after initial start or after resuming from halted load demand This timer is set by Load Demand Initial Delay PCC3300 MLD controls only
Load Demand Start Delay Timer	Indicates the time remaining before next generator set is allowed to start This timer is set by Load Demand Start Delay PCC3300 MLD controls only

Parameter	Description
Load Demand Stop Delay Timer	Indicates the time remaining before next generator set is allowed to stop This timer is set by Load Demand Stop Delay PCC3300 MLD controls only
Load Demand Inhibit Local	Indicates the status of the Load Demand Inhibit input When Active all the generator sets will start PCC3300 MLD controls only
Load Demand Genset Status Table	Indicates the load demand priorities and status of all load demand system network connected generator sets PCC3300 MLD controls only
Genset ID	Generator set identifier. All load demand generator sets must have a unique Genset ID PCC3300 MLD controls only
Load Demand Genset Run Hours	Run hour accumulator used for load demand run hour equalization This is writable Allowed Values: 0~999999.9 hours (Default: 0 hours) PCC3300 MLD controls only
System Network Datalink Status	Indicates communication status of the local generator set on system network (used for load demand) PCC3300 MLD controls only
Load Demand Spare Capacity Request Status	Indicates the status of the spare capacity request input When Active additional spare capacity (set by Load Demand Spare Capacity Request Value) is requested PCC3300 MLD controls only

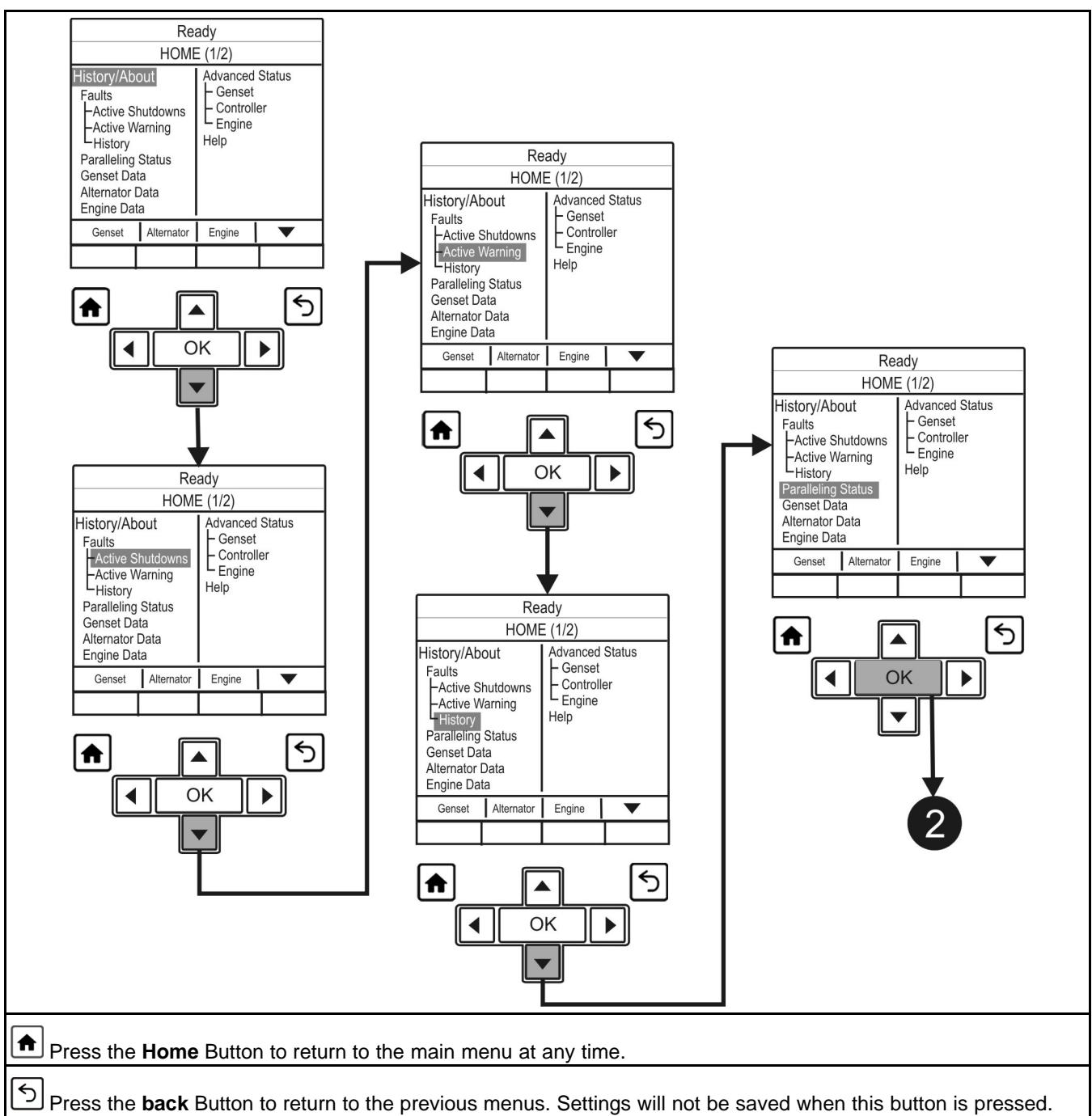

FIGURE 27. PARALLELING STATUS DATA SHEET 1 - TYPICAL DATA

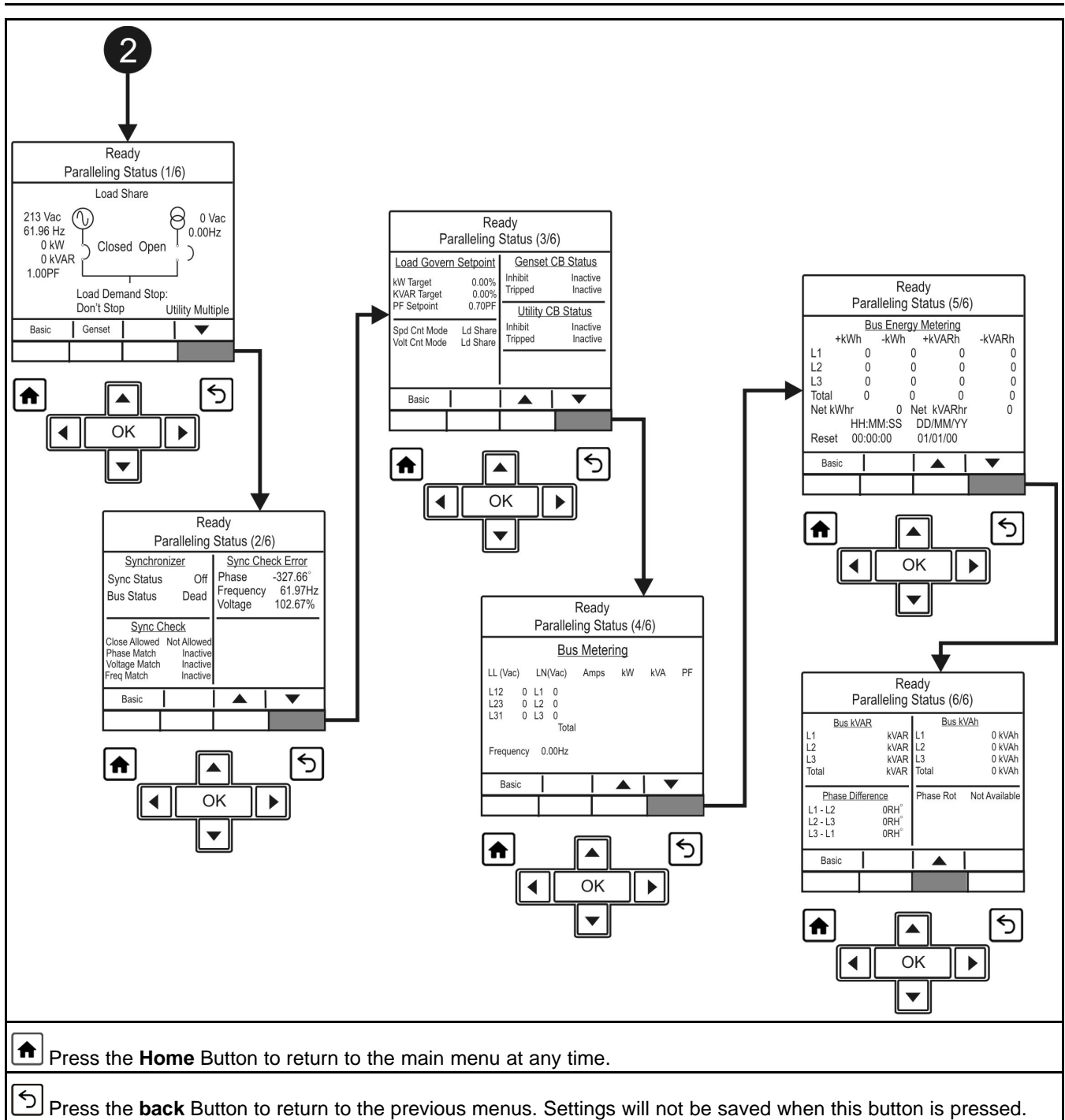

FIGURE 28. PARALLELING STATUS DATA SHEET 2 - TYPICAL DATA

4.11 Operator Panel - Paralleling/Basic Setup Menu

Figure 29 on page 75 and Figure 30 on page 76 show block representations of a typical Paralleling/Basic Setup menu.

To navigate from the HOME (1/2) menu, press the soft-key button below the down arrow in the display window. This will show the second page of the home menu (HOME 2/2). Using the up and down arrows, toggle down until the Paralleling/Basic Setup text is highlighted.

With the Paralleling/Basic Setup line of text highlighted, press the **OK** button. This will then display the Paralleling/Basic Setup Menu.

NOTICE

It is also possible to shortcut to this menu by pressing the soft-key button below the function button indicating Basic within the Paralleling Status menu.

Use the 2 soft-key buttons below the up and down arrows [▲ and ▼] to page through the 6 pages of the Paralleling/Basic Setup menu.

The adjustment of these submenus is intended for qualified service personnel and site personnel only and may require a user password for this operation. If a password is required the user password menu will appear when you try to modify the menu. (Refer to Password Menu in [Section 4.12.1.1 on page 77](#))

NOTICE

Should any of these settings require amendment or change, please contact your authorized service center.

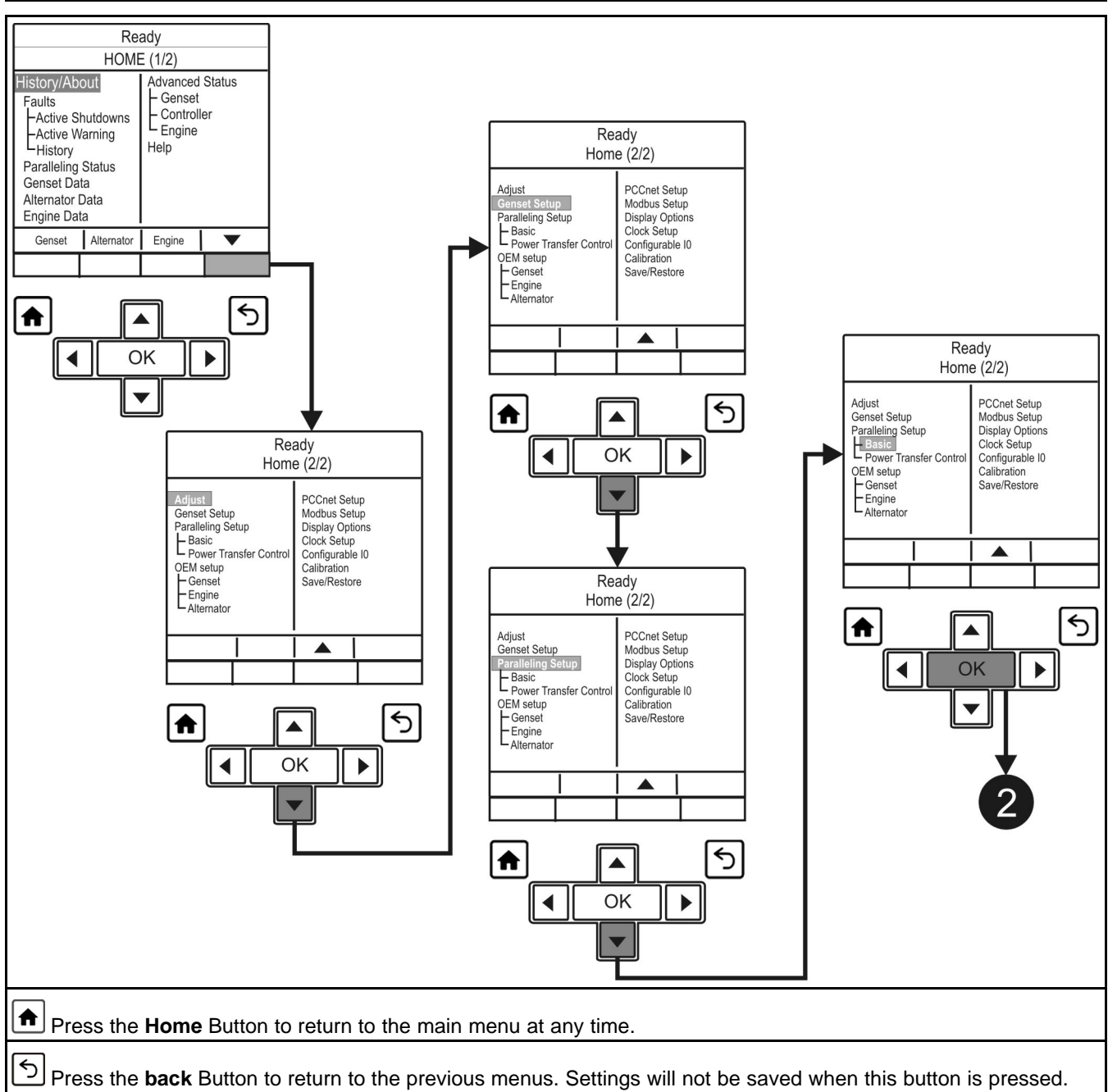

FIGURE 29. PARALLELING/BASIC DATA (SHEET 1 OF 2) - TYPICAL DATA

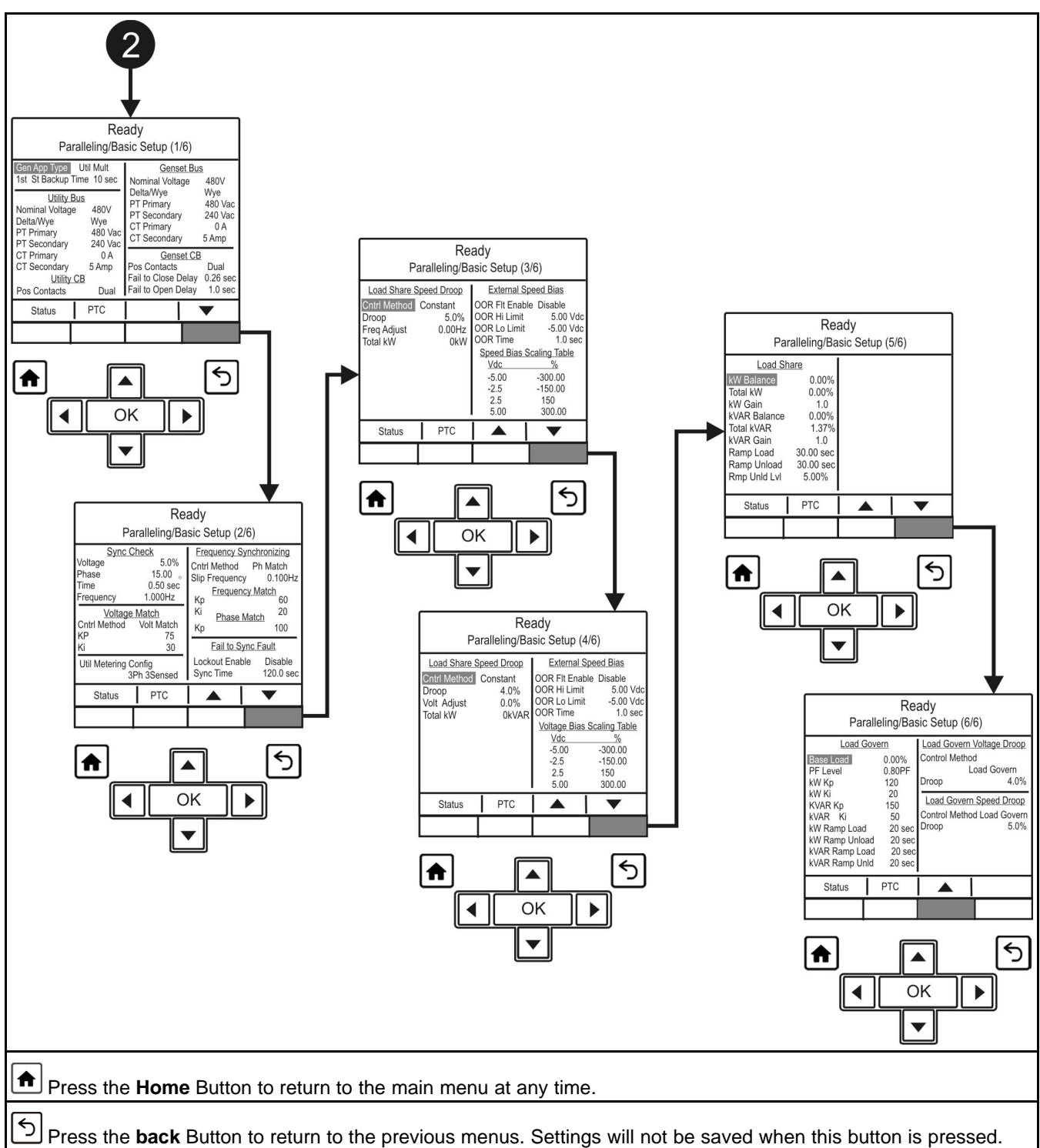

FIGURE 30. PARALLELING/BASIC DATA (SHEET 2 OF 2) - TYPICAL DATA

4.12 Selecting Operating Modes

4.12.1 Passwords and Mode Change Access

4.12.1.1 Entering the Mode Change Access Code

The Mode Change submenus are intended for qualified service personnel and site personnel only, and by default will require an Access password. If a password is required, the Mode Change – Access Code menu will appear when you try to switch between Auto, Manual Run, or Stop modes.

To enter the mode access code:

1. With the first character highlighted, press the up and down arrow buttons until the required value is displayed.
2. Press the left arrow button to move to the next numeric character.
3. Repeat steps 1 and 2 until all characters of the Access Code are correct.
4. After you have completed entering the password, press the **OK** button.

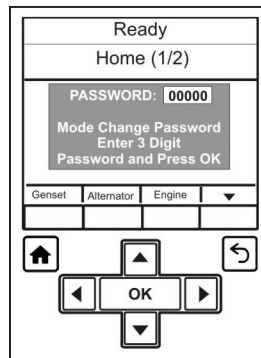

FIGURE 31. MODE CHANGE ACCESS CODE DISPLAY SCREEN

NOTICE

If an incorrect password is entered, the Operator menu that was displayed before Auto, Manual Run, or Stop mode was selected is re-displayed.

4.12.1.1.1 Passwords

It is possible for the operator to view every parameter in the graphical display; however, a password may be required before adjustment of a parameter is permitted. The generator set will prompt you if a password is required and inform you of the level of password required.

TABLE 16. PASSWORDS



Level	Description	Comment
0	No password	None required
1	Operator password	Restricted
2	Service password	Restricted
3	Engineering password	Restricted

4.12.2 Selecting Manual Run Mode

NOTICE

When changing modes, the generator set may start or stop without warning. Make sure there is no danger to personnel or equipment should the generator set unexpectedly start or stop.



Press the **Manual** button  and then (within ten seconds) the **Start** button . This bypasses the "Time Delay to Start" function and activates the engine control system and the starting system.



If the engine does not start, the starter disengages after a specified period of time and the controller indicates a "Fail to Start" shutdown.

The generator set can be configured for 1–7 starting cycles with set times for crank and rest periods for all starting modes (manual/remote). The default setting is 3 start cycles, composed of 15 seconds of cranking and 30 seconds of rest.

NOTICE

The InPower service tool or access to the setup menu is required to change the cycle number, and crank and rest times. Contact your authorized distributor for assistance.



To clear a Fail to Start shutdown, press the **Stop** button  and then press the **Reset** button .



Before attempting to restart, wait 2 minutes for the starter motor to cool and repeat the starting procedure. If the engine does not run after a second attempt, refer to the Troubleshooting section.

4.12.3 Selecting Auto Mode

NOTICE

When changing modes, the generator set can start or stop without warning. Make sure there is no danger to personnel or equipment should the generator set start or stop.

NOTICE

Make sure that it is safe to do so before proceeding to change the mode.



Press the **Auto** button . This allows the generator set to be started from a remote switch or device (e.g. transfer switch).

In response to the **Remote Start**, the control lights the Remote Start indicator and initiates the starting sequence. This start incorporates a Time Delay to Start function.

NOTICE

The InPower service tool or access to the setup menu is required to change the cycle number, and crank and rest times. Contact your authorized distributor for assistance.

NOTICE

Should a remote start signal be received, the generator set starts automatically. Make sure there is no danger to personnel or equipment should the generator set start without warning.

The starting/stopping sequence for a remote start is as follows:

1. A Remote Start signal is received at the customer connection on the generator set. This input signal is received from a transfer switch, a remote start switch, etc.
2. The Time Delay to Start (0–300 seconds) begins.
3. When the Time Delay to Start has expired, the engine starts. Once it has reached its rated speed and voltage, the generator set is available for use.
4. When the Remote Start signal is removed, a Time Delay to Stop (0–600 seconds) begins. This time delay is used to transfer the load, if connected to another power source, and let the engine cool down.
5. When the Time Delay to Stop has expired, the engine stops.

NOTICE

If the emergency stop or control off button is pressed at any time during the starting/stopping sequence, the engine immediately stops, bypassing the cooldown sequence.

4.12.4 Selecting Off Mode

NOTICE

When changing modes, the generator set can stop without warning. Make sure there is no danger to personnel or equipment should the generator set stop.



Press the **Stop** button  to put the generator set into the Off mode. This disables Auto and Manual modes.

If the generator set is running in either Manual or Auto mode, and the **Stop** button is pressed, the engine will shut down. This action may include a cool down run.

NOTICE

Do not perform a hot shutdown under load; a hot shutdown may result in engine damage.

4.13 Changing the Display Language on the HMI

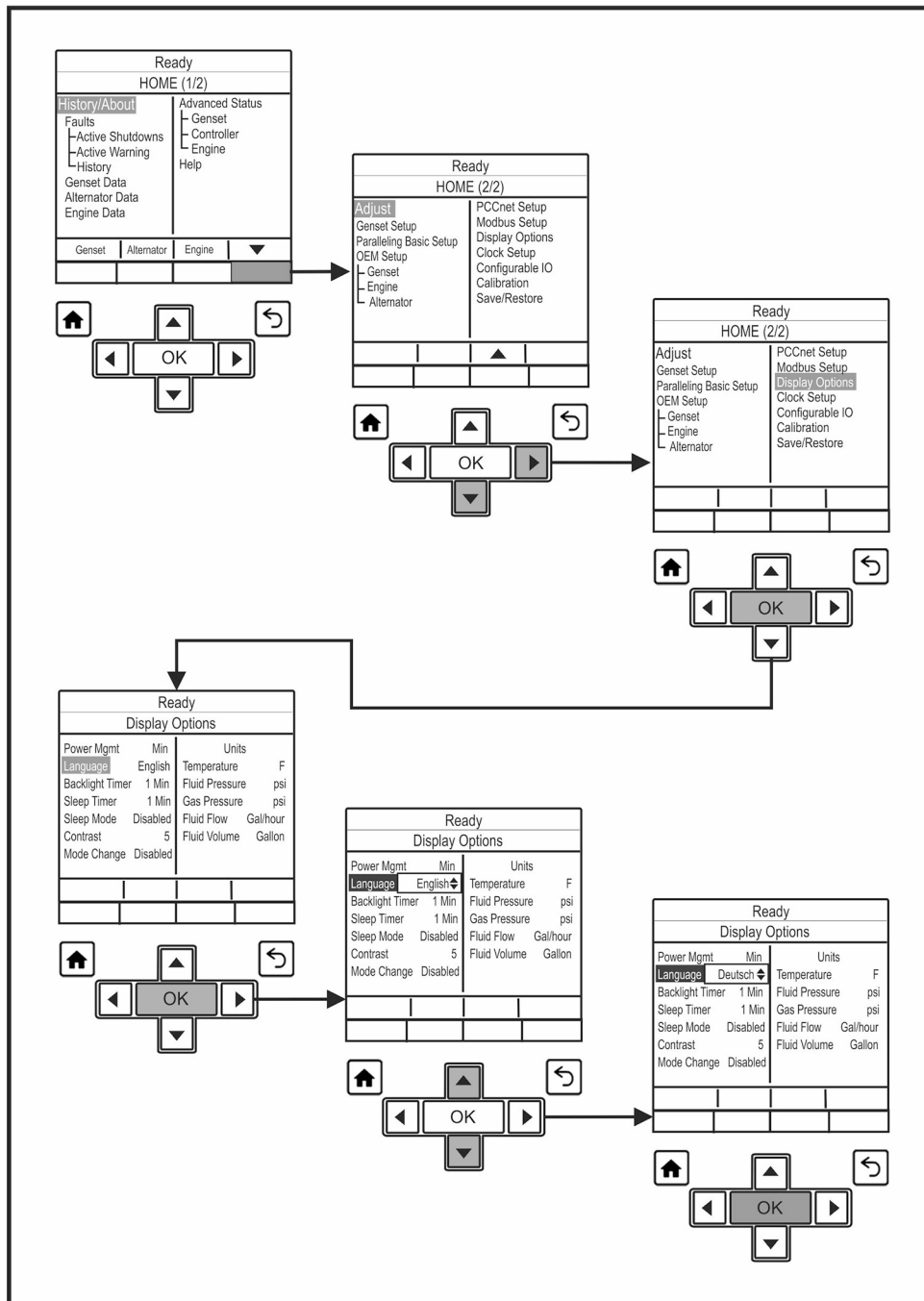

FIGURE 32. CHANGING THE DISPLAY LANGUAGE MENUS

1. Press the **Home** button.
2. Press the page down arrow to move to Home page 2.
3. Use the scroll arrows to select **Display Options** and press **OK**.
4. Scroll down to select **Languages** and press **OK**.
5. Use the up and down scroll buttons to select the required language and press **OK**.

5 Operation - PowerCommand 3.3

5.1 Safety

WARNING

Toxic Gases

Inhalation of exhaust gases can cause asphyxiation and death.

Use extreme care during installation to provide a tight exhaust system. Terminate exhaust pipes away from enclosed or sheltered areas, windows, doors, and vents. Do not use exhaust heat to warm a room, compartment, or storage area.

WARNING

Hazardous Voltage

Contact with high voltages can cause severe electrical shock, burns, or death.

Do not open the generator set output box while the generator set is running. Read and observe all warnings and cautions in the generator set manuals.

CAUTION

Hazardous Voltage

Contact with high voltages can cause severe electrical shock, burns, or death.

Make sure that only suitably trained and experienced service personnel perform electrical and/or mechanical service. Even with the power removed, improper handling of components can cause electrostatic discharge.

Only trained and experienced personnel should carry out generator set operations. Before operating the system, the operator should become familiar with all health and safety procedures, warnings, cautions, precautions, and the other documentation supplied with the generator set. Observe all of the warnings and cautions at all times.

NOTICE

Before operating the generator set become familiar with the equipment and how it is operated (including all controls, manually operated valves, and alarm devices). Safe and efficient operation can only be achieved if the generator set is operated correctly.

5.2 Introduction

This section describes the operation of the generator set. The text should be read in conjunction with the System Overview and the Control System Sections of this manual.

All indicators, control switches/buttons, and graphical display are located on the face of the Operator Panel as illustrated in [Figure 13 on page 40](#).

5.3 Maintenance

To ensure maximum performance and reliability from your generator set, it is essential that certain components are inspected periodically and, where necessary, maintenance procedures are carried out, as detailed in the Maintenance chapter.

5.4 Operating Recommendations

5.4.1 Running-in

Refer to the *Maintenance* chapter of this manual. Special running-in oils are not recommended for new or rebuilt Cummins engines. Use the same type of oil during running-in as is used in normal operation.

The engine should be run at varying loads during the first few hours of operation to allow the components to bed in. Avoid long periods of light load or full load running particularly during the early life of the engine.

5.4.2 No and Low Load Operation

Periods of no and low load operation less than 30% standby rating should be held to no longer than 15 minutes. Longer periods of operation at these conditions can result in engine or aftertreatment damage.

If it is necessary to keep the engine running for long periods of time when no electric output is required, best engine performance will be obtained by connecting a load of at least 30% rated load, but not to exceed rated load. Such a load could consist of a heater element or load bank.

5.4.3 Exercise Period

Generator sets on continuous standby must be able to go from a cold start to being fully operational in a matter of seconds. This can impose a severe burden on engine parts.

Regular exercising keeps engine parts lubricated, prevents oxidation of electrical contacts, and in general helps provide reliable engine starting.

Exercise the set for a minimum of 30 minutes with load at least once each month so that the engine reaches normal operating temperatures.

5.4.4 Low Operating Temperatures

NOTICE

Operating engines at idle (650–1000 rpm) in cold ambient temperatures wastes fuel, accelerates wear, and can result in serious engine damage. Under low temperature conditions, incomplete combustion will occur, allowing deposits of unburned tars and carbon to build up on the valve guide and valves, and eventually cause valve sticking.

In cold climates it is critical that the following items are appropriately maintained and selected based on ambient operating temperatures. Check to make sure:

- The battery is properly sized.
- An appropriate mixture of antifreeze is used in the cooling system.
- The proper grade of fuel is being used.
- The correct weight of engine oil is being used.

Use a coolant heater if a separate source of power is available. The optional heater available from Cummins will help provide reliable starting under adverse weather conditions. Make sure the voltage of the separate power source is correct for the heater element rating.

5.4.5 High Operating Temperatures

In high ambient temperatures, when operating at full load, it is normal for the high temperature warning to be given. This indicates that the engine is operating close to its maximum capacity and is normal. If operation in high temperature environments is anticipated, increase the frequency of checks for coolant level and make sure all generator set doors are closed. Also, clear obstructions of cooling air inlets and outlets, and remove debris at the radiator.

Refer to the generator set nameplate for the maximum operating temperature, if applicable.

5.4.6 Operating Conditions

NOTICE

All generator sets supplied by Cummins must be run under the following operating conditions, and in accordance with the operating information contained within the literature package supplied with each generator set.

5.4.6.1 Continuous Power Rating (COP) for Constant Load Applications

The Continuous Power Rating (COP) is applicable to utility parallel and other non-variable load applications for supplying power continuously to a load of up to 100% of the continuous rating for an unlimited number of hours per year between the stated maintenance intervals and under stated ambient conditions. All maintenance must be carried out as prescribed in Cummins manuals. No overload capability is available at this rating. This rating is applicable for utility base load operation. In these applications, generator sets are operated in parallel with a utility source and run under constant loads for extended periods of time.

5.4.6.2 Prime Power Rating (PRP) for Variable Load Applications

The Prime Power Rating (PRP) is the maximum power available during a variable load sequence which may be run for an unlimited number of hours per year, between the stated maintenance intervals and under the stated ambient conditions. All maintenance must be carried out as prescribed in Cummins manuals. Prime power applications fall into one of the following two categories:

- Unlimited time prime power (for variable load applications)

Prime power is available for an unlimited number of annual operating hours in variable load applications. The permissible average power output under variable load shall not exceed a 70% average of the prime power rating during any operation of 250 hours. The total operating time at 100% prime power shall not exceed 500 hours per year. A 10% overload capability is available for a period of 1 hour within a 12-hour period of operation, in accordance with ISO 8528-1-2018. Total operating time at the 10% overload power shall not exceed 25 hours per year.

- Limited running time prime power (for constant load applications) (LTP)

Prime power is available for a limited number of hours in a non-variable load application. It is intended for use in situations where power outages are contracted, such as utility power curtailment. Generator sets may be operated in parallel with the public utility up to 750 hours per year at power levels never to exceed the prime power rating. No sustained overload capability is available at this rating. The customer should be aware, however, that the life of any generator set will be reduced by constant high load operation. Any operation exceeding 750 hours per year at the prime power rating should use the Continuous Power Rating.

5.4.6.3 Emergency Standby Power Rating (ESP) for Variable Load Applications

The Emergency Standby Power Rating (ESP) is applicable for supplying emergency power for the duration of a utility power interruption, between the stated maintenance intervals and under the stated ambient conditions. All maintenance must be carried out as prescribed in Cummins manuals. No overload capability is available for this rating and utility parallel operation is not permitted at the standby power rating. For applications requiring sustained utility parallel operation, the limited time prime power rating or continuous power rating must be utilized as applicable.

This rating is applicable to installations served by a reliable normal utility source. Generator sets should be sized for a maximum average load factor of 80% of the standby power rating with a maximum of 200 hours of operation per year, which includes less than 25 hours per year at the standby power rating. In installations served by unreliable utility sources (where outages last longer or occur more frequently), where operation is likely to exceed 200 hours per year, the prime power rating should be applied. The standby rating is only applicable for emergency and standby applications where the generator set serves as the back up to the normal utility source. Negotiated power outages are not considered as emergencies.

5.4.6.4 Applicable to All Ratings

The following information applies to all ratings, unless otherwise agreed by the Regional Sales Manager of Cummins in writing:

- When determining the actual average power output of a variable power sequence in any of the ratings above, powers of less than 30% of the emergency standby power are taken as 30% and time at no load shall not be counted.
- Variable load is calculated in accordance with methods and formulas given in ISO 8528-1-2018.
- All three-phase generators are rated for 0.8 power factor lag. Single-phase generators are rated for 1.0 power factor.
- All ratings are based on the following reference conditions:
 - Ambient temperature: 27 °C (81 °F)
 - Altitude above sea level: 150 m (490 ft)
 - Relative humidity: 60%
- If any of the above conditions are exceeded, the output may be subject to de-rate.
- If any of the above conditions are not satisfied, the operational life of the generating set may be reduced.
- Short term parallel operation with the utility for load transfer purposes only is permitted with all ratings.

5.4.7 Derating Factors

Engine power and resulting electrical output decrease as ambient temperature or altitude increases. For derating factors applicable at specific sites, contact your authorized distributor.

5.5 Generator Set Operation

⚠ WARNING

Combustible Vapors

Engine over speeding can cause component failure, fire, or an explosion; which can cause severe personal injury or death.

Do not operate an engine where there are or can be combustible vapors.

Correct care of the engine will result in longer life, better performance, and more economical operation.

Numerous safety devices may be available, such as air intake shutoff devices, to minimize the risk of overspeeding in which an engine, because of application, might operate in a combustible environment (from a fuel spill or gas leak, for example). Cummins does not know how the engine will be used. The equipment owner and operator, therefore, is responsible for safe operation in a hostile environment. Consult your authorized distributor for further information.

NOTICE

Cummins recommends the installation of an air intake shutoff device or a similar safety device to minimize the risk of overspeeding where an engine will be operated in a combustible environment.

NOTICE

Long periods of idling (more than ten minutes) can damage an engine. Do not idle the engine for excessively long periods.

5.5.1 Sequence of Operation

The generator set is run automatically using a **Remote Start** signal, or manually using the generator set control panel buttons. LEDs are provided on the operator panel to indicate the operating run mode of the generator set. The PowerCommand® control initiates a starter cranking signal and performs an automatically sequenced manual start, under a complete engine protection system combined with full monitoring capability. If a fault is sensed at start-up, the engine is locked out and will not start.

The choice of **Auto** or **Manual Run** mode is decided by authorized personnel during the generator set initial setup. An access code is required to switch between the **Auto**, **Manual Run**, or **Off** modes, and this facility may be permitted or denied by the authorized personnel during the initial setup of the generator set.

5.6 Before Starting

NOTICE

One operator should be in complete charge, or working under the direction of someone who is in charge. Remember that, upon starting the engine, cables and switchgear will become energized, possibly for the first time. Furthermore, equipment that does not form part of the generator set installation may become electrically charged. Only authorized and competent personnel should carry out this work.

NOTICE

Do not use the Emergency Stop button to shut down an engine unless a serious fault develops. The Emergency Stop button must not be used for a normal shut-down as this will prevent a cooling down run in which the lubricating oil and engine coolant carry the heat away from the engine combustion chamber and bearings in a safe manner.

NOTICE

***Diesel engines only:* Avoid off-load running for other than short periods. A minimum loading of 30% is recommended. The engine must be shut down as soon as possible after the appropriate functions have been checked.**

NOTICE

***Gaseous engines only:* Avoid running the generator set at no-load and light-loads for extended periods.**

Before attempting to start the generator set, the operator should read through this entire manual and the specific literature provided as part of the documentation pack supplied with the generator set. It is essential that the operator be completely familiar with the generator set and the PowerCommand® control.

The sub-sections below cover the systems used to start and stop the generator set.

Before starting the generator set, make sure that exhaust and fuel fittings are tight and properly positioned, and that proper maintenance and pre-start checks have been performed.

During starting, automatic checks are carried out for the integrity of various protection systems. The PowerCommand® control will not allow the generator set to continue the starting sequence if the integrity of a sensor is considered to be in doubt.

The generator set can be configured for a number of starting cycles (one to seven) with set times for crank and rest periods for all starting modes (manual/remote). The default setting is for three start cycles, composed of fifteen seconds of cranking and 30 seconds of rest.

NOTICE

The number of starting cycles, and the crank and rest times are set from within the Setup menu. Trained and experienced service personnel are required to change the default setting. Contact your authorized Cummins distributor.

5.6.1 Operator's Pre-Start Checks

 WARNING***Arc Flash and Shock Hazard***

Electric arc flash can cause electrical shock, severe burns, or death.

Make sure the alternator is dry before the generator set is operated.

⚠ WARNING
<p>Hot Pressurized Liquid Contact with hot liquid can cause severe burns. Do not open the pressure cap while the engine is running. Let the engine cool down before removing the cap. Turn the cap slowly and do not open it fully until the pressure has been relieved.</p>

NOTICE
<p>Radiators with 2 fill necks only: Both fill necks must be filled when the cooling system has been drained.</p>

TABLE 17. OPERATOR’S PRE-START CHECKS

Check	Description
Fuel Supply (Diesel Only)	<p>Make sure that:</p> <ul style="list-style-type: none"> • The fuel tank is filled to the normal level with clean water-free fuel and that the fuel system is primed. • All the valves required for operation are open. • There are no leaks and that all fittings are tight. • If equipped, the auxiliary fuel system is properly connected.
DEF Supply (If Equipped)	<p>Make sure that:</p> <ul style="list-style-type: none"> • The DEF tank is filled to the normal full level with DEF. • If equipped, the auxiliary DEF system is properly connected.
Lubrication	With the engine stationary, check the engine lubrication oil level and make sure that the correct level is always maintained.
Coolant	Check the engine coolant level and make sure that the level is always maintained at the coolant expansion tank. Fill the cooling system to the bottom of the fill neck in the radiator fill or expansion tank. Do not check while the engine is hot.
Cooling Air Inlet/Outlets	Make sure that the cooling air inlets/outlets are unobstructed.
Exhaust Outlet	<p>Make sure that:</p> <ul style="list-style-type: none"> • Exhaust components are secured and not warped. • The exhaust outlet is unobstructed. • No combustible materials are near the system. • Gases are discharged away from building openings. • There are no leaks and that all fittings are tight.
Batteries	Make sure that the batteries are charged, and that all connections are clean, correct and tight (if applicable).
Auxiliary Powered AC Supplies	Make sure that all auxiliary equipment is receiving power from the customer’s supply.
Emergency Stop	Make sure that the emergency stop button is fully operational.

5.6.2 Starting at Operator Panel (Manual Run Mode)

NOTICE

Make sure that all Pre-start Checks are carried out before starting the generator set. Do not attempt to start the generator set until it is safe to do so. Warn all others in the vicinity of the generator set and the connected load equipment that the generator set is about to start.

1. Make sure the main circuit breaker is in the open position.

2. To start the generator set in the **Manual Run** mode, press the **Manual** button  on the Operator



Panel, and then press the **Start** button  within ten seconds. Failure to press the **Start** button within this time will result in the generator set changing to the **Off** mode. (Refer also to [Section 4.12.2 on page 78](#)).

NOTICE

If the mode change access code feature has been enabled, enter the access code when prompted. (See [Section 4.12.1 on page 77](#)).

The PowerCommand® control will initiate a starter cranking signal and will perform an automatically sequenced manual start, under a complete engine protection system combined with full monitoring capability. This will activate the engine control system and the starting procedure. The starter will begin cranking, and after a few seconds the engine will start and the starter will disconnect.

Should the engine fail to start, the starter will disengage after a specified period of time and the control will indicate a Fail to Start shutdown.

To clear a Fail to Start shutdown, press the **Stop** button  and then press the **Reset** button.  Before attempting to re-start wait a minimum of two minutes for the starter motor to cool and then repeat the starting procedure. If the engine does not run after a second attempt, refer to [Chapter 8](#).

To disable **Manual** mode, change to **Auto** or **Off** mode. If the generator set is running when it leaves **Manual** mode, it will continue to run if **Auto** mode has been selected and the remote start signal is active. If there is no active remote start signal, the generator set will stop.

3. Allow the engine to warm up and reach the rated speed and voltage.

4. Close the main circuit breaker and apply load as required.

5.6.3 Starting from Remote Location (Auto Mode)

NOTICE

Make sure that all Pre-start Checks are carried out before starting the generator set. Do not attempt to start the generator set until it is safe to do so. Warn all others in the vicinity that the generator set is about to start.

To start the generator set in the **Auto Run** mode, select the **Auto** button  from the Operator Panel. (Refer also to [Section 4.12.3 on page 78](#)).

Only on receipt of a remote start signal, and after a Time Delay to Start, will the PowerCommand® control initiate the starting sequence as above.

The Remote Start LED will be lit.

There are two start modes that are selectable for the Remote Start input; one for non-emergency start and the other for emergency start. In the non-emergency start, the control will complete the warm-up at idle. In the emergency mode, the generator set will omit the warm-up stage and proceed directly to rated speed and voltage.

In response to the Remote Start signal, or the control detects the loss of the Utility voltage, the control lights the Remote Start indicator and initiates the starting sequence, except for the following:

- In Auto position, the control will complete the Time Delay to Start (0 to 300 seconds) for a non-emergency start signal only.

NOTICE

If the mode change access code feature has been enabled, enter the access code when prompted. (See [Section 4.12.1 on page 77](#))

To disable **Auto** mode, change to **Manual** or **Stop** mode. Refer to [Section 5.7 on page 90](#).

5.6.4 Cold Starting with Loads

NOTICE

Make sure that all prestart checks are carried out before starting the generator set. Do not attempt to start the generator set until it is safe to do so. Warn all others in the vicinity that the generator set is about to start.

Use a coolant heater if a separate source of power is available. The optional heater available from Cummins will help provide reliable starting under adverse weather conditions. Be sure the voltage of the separate power source is correct for the heater element rating.

Cummins recommends equipping standby generator sets (life safety systems) with engine water jacket coolant heaters to maintain the coolant at a minimum of 32 °C (90 °F) and, for most applications, accept the emergency load in ten seconds or less. Although most Cummins generator sets will start in temperatures down to -32 °C (-25 °F) when equipped with engine water jacket coolant heaters, it might take more than ten seconds to warm the engine up before a load can be applied when ambient temperatures are below 4 °C (40 °F).

The **Low Coolant Temp** (Code 1435) message along with the lighting of the **Warning** LED are provided to alert the operator of a possible delay in accepting the load. The engine cold sensing logic initiates a warning when the engine water jacket coolant temperature falls below 21 °C (70 °F). In applications where the ambient temperature falls below 4 °C (40 °F), a cold engine may be indicated even though the coolant heaters are connected and functioning correctly. Under these conditions, although the generator set may start, it may not be able to accept load within ten seconds. When this condition occurs, check the coolant heaters for correct operation. If the coolant heaters are operating correctly, other precautions may be necessary to warm the engine before applying a load.

5.6.4.1 Checking Coolant Heater Operation

⚠ WARNING

Hot Surfaces

Contact with the hot surfaces can cause severe burns.

Avoid contact with hot parts. Allow hot parts to completely cool.

Do not touch the cooling system outlet hose. The coolant heater is operating if radiant heat can be felt with your hand held close to the outlet hose and the engine is not running.

5.7 Stopping

NOTICE

The access code may be required before initiating the Off button sequence. See the Passwords and Mode Change Access section.

NOTICE

Run the generator set at no load for three to five minutes before stopping. This allows the lubricating oil and engine coolant to carry heat away from the combustion chamber and bearings.

5.7.1 Stopping at the Operator Panel (Manual Mode)

NOTICE

If possible, hot shutdown under load should be avoided to help prolong the reliability of the set. A hot shutdown results in a Hot Shutdown Warning.

NOTICE

Hot shutdown under load should be avoided whenever possible to prolong the reliability of the set. A hot shutdown may result in a Hot Shutdown Warning.

NOTICE

Pressing the **Stop** button twice stops the generator set immediately without a cool down run after which the set enters the Off mode.

To shut down a generator set that was started in Manual mode.

1. Remove the load.
2. Open the main circuit breaker.
3. Press the **Stop** button on the HMI operator panel. This initiates the generator set cool down run. The HMI displays the cool down count down timer. Once the cool down timer has expired, the generator set shuts off and enters Off mode.

5.7.2 Stopping from Operator Panel (Auto Mode)

If the generator set was started in Auto mode, press the **Stop** button  once to stop the generator set immediately without a Cooldown run. Thereafter, the generator set enters the Off mode.

If possible re-start the generator set in Manual mode with the circuit breaker open, and allow to stop with a Cooldown run.

NOTICE

If possible, hot shutdown under load should be avoided to help prolong the reliability of the set. A hot shutdown will result in a Hot Shutdown Warning.

NOTICE

When MLD is enabled, stopping a generator set may cause one or more stopped generator sets to start.

5.7.3 Stopping from Remote Location (Auto Mode)

If the control receives a remote stop signal, the generator set completes its normal shutdown sequence incorporating a cooldown run (Refer to [Section 4.12.3](#)). The remote stop signal is actually the removal of the remote start signal to the control.

The generator set stops after completing the following cooldown sequence:

- Time delay to Stop function (0–600 seconds)
- Cooldown at idle (0–10 minutes) or longer, if necessary to obtain normal operating temperature before shutdown.

The set will remain in the Auto mode, and subject to a remote start signal, unless the **Stop** button is pressed. If this button is pressed the set will enter the Off mode.

NOTICE

The InPower service tool or access to the Setup menus is required to enable and change the time delay start/stop settings. Contact your authorized distributor for assistance.

5.7.4 Code 1433 or 1434 - Emergency Stop

The local **Emergency Stop** button is situated on the front of the operator panel. This is a mechanically latched switch that will unconditionally stop the engine when pressed, bypassing any time delay to stop. Push this button for emergency shutdown of the engine.

NOTICE

If the engine is not running, pushing the button will prevent the starting of the engine, regardless of the start signal source (Manual or Auto - Remote).

When the **Stop** button is pressed, the display will indicate the shutdown condition by illuminating the red

Shutdown status LED  and displaying the following message on the graphical LCD display:

- Fault Number: 1433 LOCAL EMERGENCY STOP

A remote **Emergency Stop** button may be incorporated within the installation. If this remote **Emergency Stop** button is activated, the following message will be displayed:

- Fault Number: 1434 REMOTE EMERGENCY STOP

To reset:

1. Pull, or twist and pull the button out.
2. Press the **Stop** button on the operator panel to acknowledge this action.

3. Press the **Reset** button.
4. Press the **Auto** or **Manual Run** button, as previously determined. See the *Selecting Operating Modes* section.

NOTICE

Do not use an Emergency Stop button to shut down an engine unless a serious fault develops. The Emergency Stop button must not be used for a normal shut-down because this will prevent a cooling down run in which the lubricating oil and engine coolant safely carry away heat from the engine combustion chamber and bearings.

NOTICE

Make sure that the cause of the Emergency Stop is fully investigated and remedied before a fault reset and generator set start are attempted.

NOTICE

An Emergency Stop button is situated in close proximity to the operator panel viewing window.

5.8 Frequency Changing

⚠ WARNING

Hazardous Voltage

Contact with high voltages can cause severe electrical shock, burns, or death.

Make sure that only technically trained and experienced service personnel adjust the voltage and frequency settings. These settings may only be adjusted to correspond to the parameters of the installed input power supply.

NOTICE

Any change to the frequency settings must only be carried out by the rental fleet owner.

Within the PowerCommand® control Setup menu is the option to select 50 Hz or 60 Hz running. This option is password protected and is determined at the initial setting up of the generator set.

The Setup menu is used to control the displaying of a further menu that allows for adjusting the generator set frequency settings.

The Frequency menu is designed only for use with rental generator sets. Changing the parameters on this menu must only be done by trained service personnel.

5.9 Paralleling Operation

5.9.1 Speed and Voltage Matching

Once the generator set has achieved nominal voltage and frequency, the set is ready to be paralleled with the busbar supply. Each generator set is paralleled completely independently of any others.

The PowerCommand® 3.3 control unit monitors both the incoming supply and the busbar voltage and frequency. It adjusts the incoming supply to match the busbar supply over a wide span of busbar parameters. Synchronization is achieved under full control and at the correct phase coincidence.

In Automatic mode, the PowerCommand® 3.3 control receives a breaker close signal when synchronization has been achieved, and signals the main breaker to close. In Manual mode, the main breaker is closed to connect the generator set to the busbars by using the breaker Close button.

NOTICE

The PowerCommand® 3.3 control performs a synchronization check in both Manual and Auto modes before allowing the generator set circuit breaker to close.

5.9.2 Operation When in Parallel

When in parallel with the busbar supply, the generator set voltage and frequency are dependent upon the busbar parameters and the control is changed to kW and kVAR load management.

Each generator set is individually controlled by a separate PowerCommand® 3.3 control.

Apart from the protection systems, there is no common coupling between generator sets. This allows for any set, or its relevant controls, to be under maintenance without affecting the others.

When the control system detects that the generator set is up to speed and voltage, the load ramps from the mains to the generator set. The engine governor control system keeps the electrical output within the correct parameters.

5.9.3 Generator Set Application Type

The generator set application type is the primary setting for configuring the paralleling features of the PowerCommand® 3.3 control. [Table 18](#) provides more information about each generator set application type. It indicates how the generator set can run in parallel, what paralleling states or processes are available together, and how much control the PowerCommand® 3.3 control over the circuit breakers.

TABLE 18. OVERVIEW OF GENERATOR SET APPLICATION STATES

Paralleling	Generator Set Application Types					
	Standalone	Synchronizer Only	Isolated Bus Only	Utility Single	Utility Multiple	Power Transfer Control
Parallel Process with Utility				■	■	■
Parallel Process with Other Generator Sets			■		■	
Paralleling States:						
• Standby	■	■	■	■	■	■
• Dead Bus/ First Start			■	■	■	
• Synchronize		■	■	■	■	■

Paralleling	Generator Set Application Types					
	Standalone	Synchronizer Only	Isolated Bus Only	Utility Single	Utility Multiple	Power Transfer Control
• Load Share			■		■	
• Load Govern				■	■	■
• Masterless Load Demand (MLD)			■			
• Generator Set CB Trip	■	■				
• Generator Set CB Control			■	■	■	■
• Utility CB Control						■

In general, generator set application types are distinguished by what may be run in parallel with the generator set. Synchronizer Only and Power Transfer Control are further distinguished by other characteristics as follows:

- *Synchronizer Only*: The generator set is not running in parallel with other generator sets or with the utility, but the PowerCommand® 3.3 control can synchronize its voltage, frequency and phase with one other power source. This is typically for use in applications with transfer switches which use fast-close transitions but do not have a built in synchronizer.
- *In Power Transfer Control*: The PowerCommand® 3.3 controls the generator set’s circuit breaker and utility circuit breaker to ensure the load has power. The PowerCommand® 3.3 control does not control the utility circuit breaker in any other generator set application type.

NOTICE

The PowerCommand® 3.3 control does not support paralleling in a Single-Phase configuration. If Single/3-Phase Configuration is set to Single-Phase, the generator set application type is Standalone.

5.9.4 Standalone Application

In the generator set application shown in [Figure 33](#), the generator set is not running in parallel with other sets or with the utility. The controller is always in the Standby state and may be in either the Power On or Sleep mode.

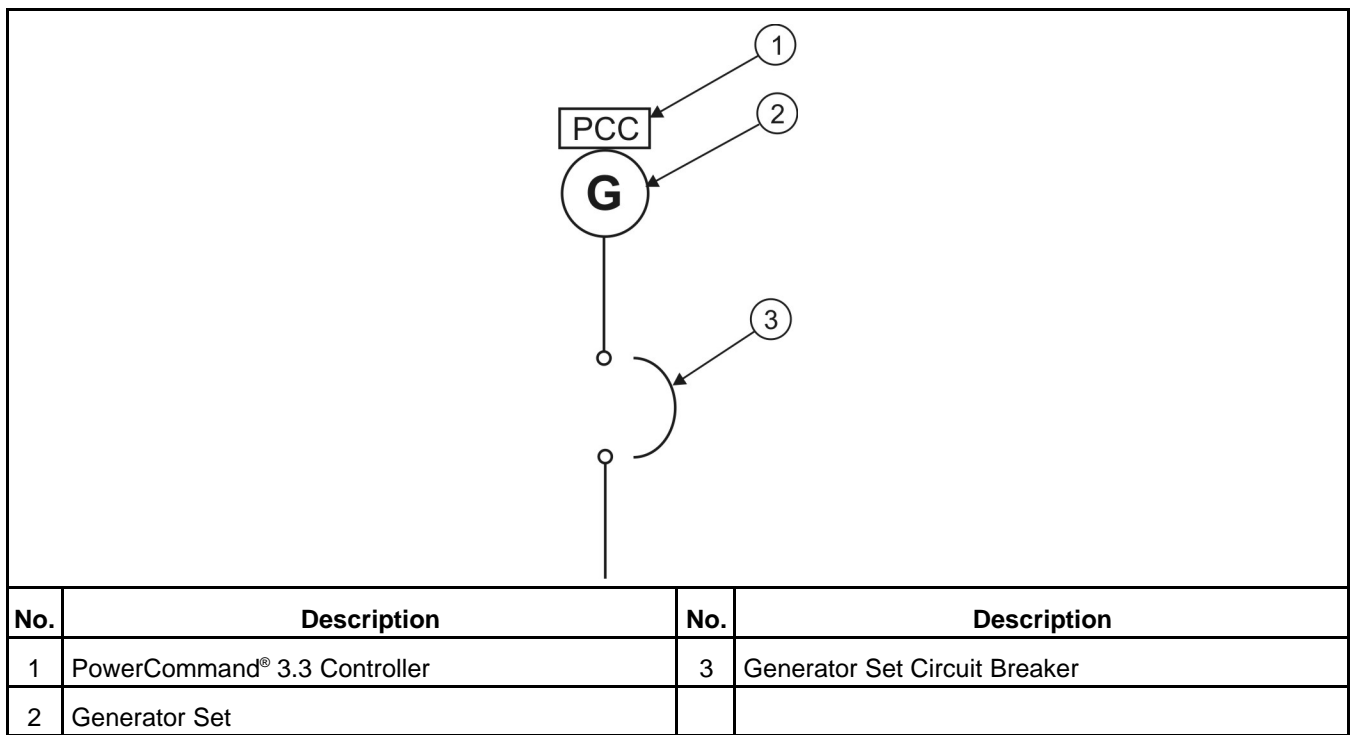

FIGURE 33. STANDALONE

When the generator set is required to accept a load, the generator set must be started in either Manual or Auto mode. When the set has run up to speed, the circuit breaker must be closed in either the Manual or Auto mode to accept the load.

5.9.5 Synchronize Only

In the generator set application shown in [Figure 34](#), the generator set is not running in parallel with other sets or with the utility, but the PowerCommand® 3.3 control can synchronize the voltage, frequency and phase with one other power source. This is typically used in applications with transfer switches that use fast-close transitions but do not have a built in synchronizer.

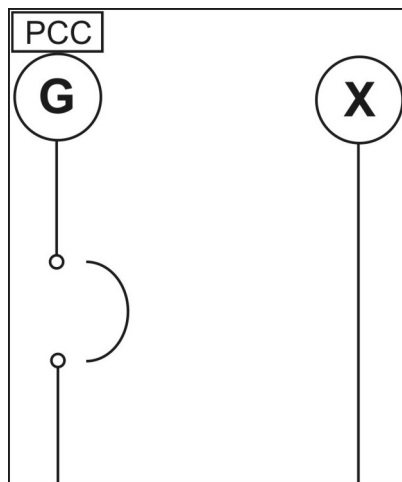

FIGURE 34. SYNCHRONIZED ONLY

The PowerCommand® 3.3 control is in the Standby paralleling state until event 1465 (Ready to Load) is active. Then the PowerCommand® 3.3 control synchronizes if all of the following conditions are met:

- The sync enable signal is active.
- The synchronizer conditions are met.

If any of these conditions are not met the PowerCommand® 3.3 control remains in the Standby paralleling state.

The Sync Enable Signal may come from the PowerCommand® 3.3 control's Sync Enable connection or Modbus networks. This signal becomes active when any of these sources are present and remains active until any of these conditions are changed. When this signal becomes active the PowerCommand® 3.3 control synchronizes with the live bus.

5.9.6 Isolated Bus Only

In the generator set application shown in [Figure 35](#), the generator set is running in parallel with other generator sets.

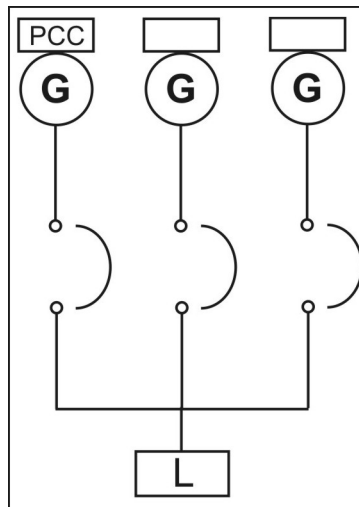

FIGURE 35. ISOLATED BUS ONLY – STANDBY PARALLELING STATE

The generator set is in the Standby paralleling state until event 1465 (Ready to Load) is active. The PowerCommand® 3.3 control then considers the current position of the generator set circuit breaker.

Before the PowerCommand® 3.3 control closes the generator set circuit breaker, all of the following conditions must be met:

- Initially the First Start process determines whether or not to close the generator set circuit breaker onto a dead bus when it is in parallel with other generator sets (provided the sets are in Auto setup).
- The generator set circuit breaker is then closed if the following conditions are met:
 1. There are no generator set circuit breaker Open requests.
 2. There is a generator set circuit breaker Close request.

If the PowerCommand® 3.3 control is in Manual mode, the CB Close button must be pressed.

NOTICE

The PowerCommand® 3.3 control inhibits closure of the paralleling breaker outside the sync-check window. Therefore the breaker close button can be operated even before synchronization, although the breaker will not close until a signal is sent from the PowerCommand® 3.3 control to allow it.

When all the above conditions are met and the generator set circuit breaker is closed, the generator set will parallel with the other generator sets to share the load.

In [Figure 36](#) the PowerCommand® 3.3 control is now in the Load Share paralleling state, all of the generator sets' circuit breakers are closed, so the load is now receiving power from all sources.

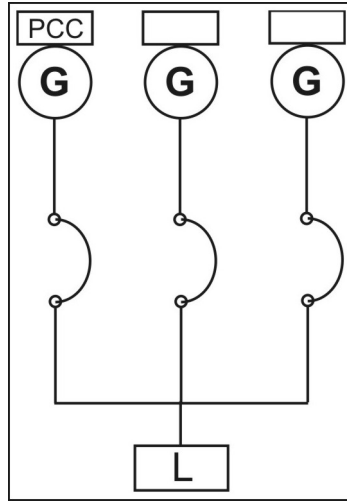

FIGURE 36. ISOLATED BUS ONLY - LOAD SHARE PARALLELING STATE

Open the generator set circuit breaker if there are any generator set circuit breaker Open requests. This places the generator set back into the Standby paralleling state and therefore no longer supplies power to the load.

5.9.7 Power Transfer Control

In the generator set application shown in [Figure 37](#) (utility circuit breaker closed and taking the load), a single generator set runs in parallel with the utility; no other generators are connected. This is the only application whereby the PowerCommand® 3.3 control controls the utility circuit breaker as well as the generator set to make sure the load has continuous power.

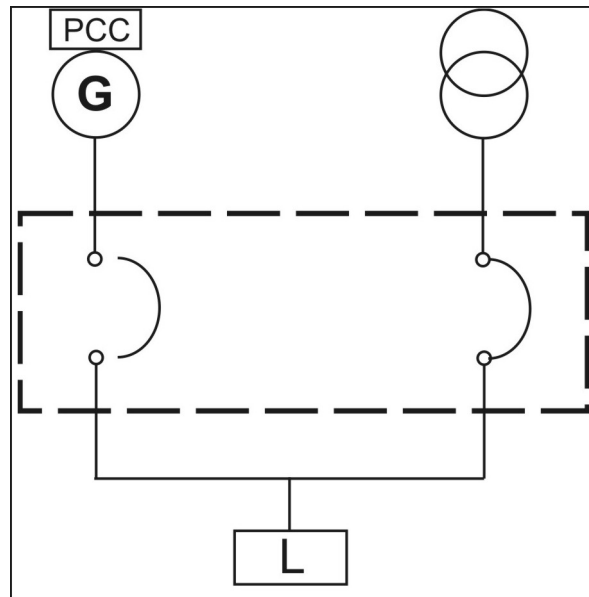

FIGURE 37. POWER TRANSFER CONTROL

The PowerCommand® 3.3 controls the generator set, the generator set circuit breaker, and the utility circuit breaker to make sure the load has power. For example, the PowerCommand® 3.3 control monitors the utility; if the utility fails, the PowerCommand® 3.3 control starts the generator and transfers the load to the generator set. When the utility is available again, the PowerCommand® 3.3 control transfers the load to the utility and shuts down the generator. In this Power Transfer Control (PTC), you can also test the generator set, exercise the generator set, and run the generator set in parallel with the utility.

NOTICE

In this generator set application type, Utility Single Mode verify/configurable input #29 function pointer must be set to Default if the PowerCommand® 3.3 control is allowed to close the generator circuit breaker onto a dead bus.

The PTC operating mode determines the conditions under which the PowerCommand® 3.3 control opens and closes the generator set circuit breaker and the utility circuit breaker, as well as conditions under which the PowerCommand® 3.3 control starts and stops the generator set.

The PTC operating mode is related to the mode of operation. [Table 19](#) provides a summary of the relationships between the mode of operation and the PTC operating mode.

TABLE 19. SUMMARY OF RELATIONSHIPS BETWEEN MODES OF OPERATION AND PTC OPERATING MODES.

Mode of Operation	Condition	PTC Operating Mode
Off	Default Mode	Off
Auto	Default Mode	Normal
	PTC Mode Switch Signal	Manual
	Exercise Signal	Exercise
	Remote Start Signal	Test
	Extended Parallel Signal	Extended Parallel
	Generator Set is Unavailable	Normal Override
	Utility is Unavailable	Utility Fail
Manual	Default Mode	Manual

5.9.7.1 Exercise Mode

In this PTC operating mode the PowerCommand® 3.3 control responds to the Exercise signal. This operating mode is similar to the test PTC operating mode with the following exceptions:

- The Exercise signal replaces the Remote Start signal (the Remote Start signal must be inactive).
- If the Exercise Scheduler is active, Scheduler Program Run mode replaces Test With Load Enable.

5.9.7.2 Extended Parallel Mode

In this PTC operating mode, the PowerCommand® 3.3 control responds to the Extended Parallel signal. The PowerCommand® 3.3 control is in the PTC operating mode when all the following conditions are met:

- Single/3-phase connection is set to 3-phase.
- The PTC mode switch signal is inactive.
- The PowerCommand® 3.3 control is in Auto mode.

- The Extended Parallel signal is active.
- Extended Parallel Enable is set to enable.
- Utility circuit breaker Position Status is set to Closed, or the generator set is available and the generator circuit breaker position status is set to Closed.

5.9.7.3 Manual Mode

This is the default PTC operating mode when Single/3-Phase Connection is set to 3-Phase and one of these conditions is met:

- The PTC mode switch signal is active.
- The PowerCommand® 3.3 control is in Manual mode.

When the PowerCommand® 3.3 control enters this PTC operating mode, it considers the current position of both the generator's and the utility's circuit breaker. However, the generator set must be started manually and the generator set's circuit breaker will not close to accept the load until the generator set is up to speed and voltage.

NOTICE

In the following sequences the PowerCommand® 3.3 control must be in the Standby Paralleling State unless otherwise stated and assumes that the PowerCommand® 3.3 control menus have been set for the correct paralleling parameters.

[Figure 38 on page 100](#), [Figure 39 on page 101](#), [Figure 40 on page 101](#) and [Figure 41 on page 102](#) illustrate the various conditions which may be set manually while in a paralleling state. In this instance, an operator controls how the load is shared by operating the circuit breakers on both the generator and the utility for the desired mode.

In [Figure 38 on page 100](#), the Utility has become unavailable while the generator set is in the Standby paralleling state.

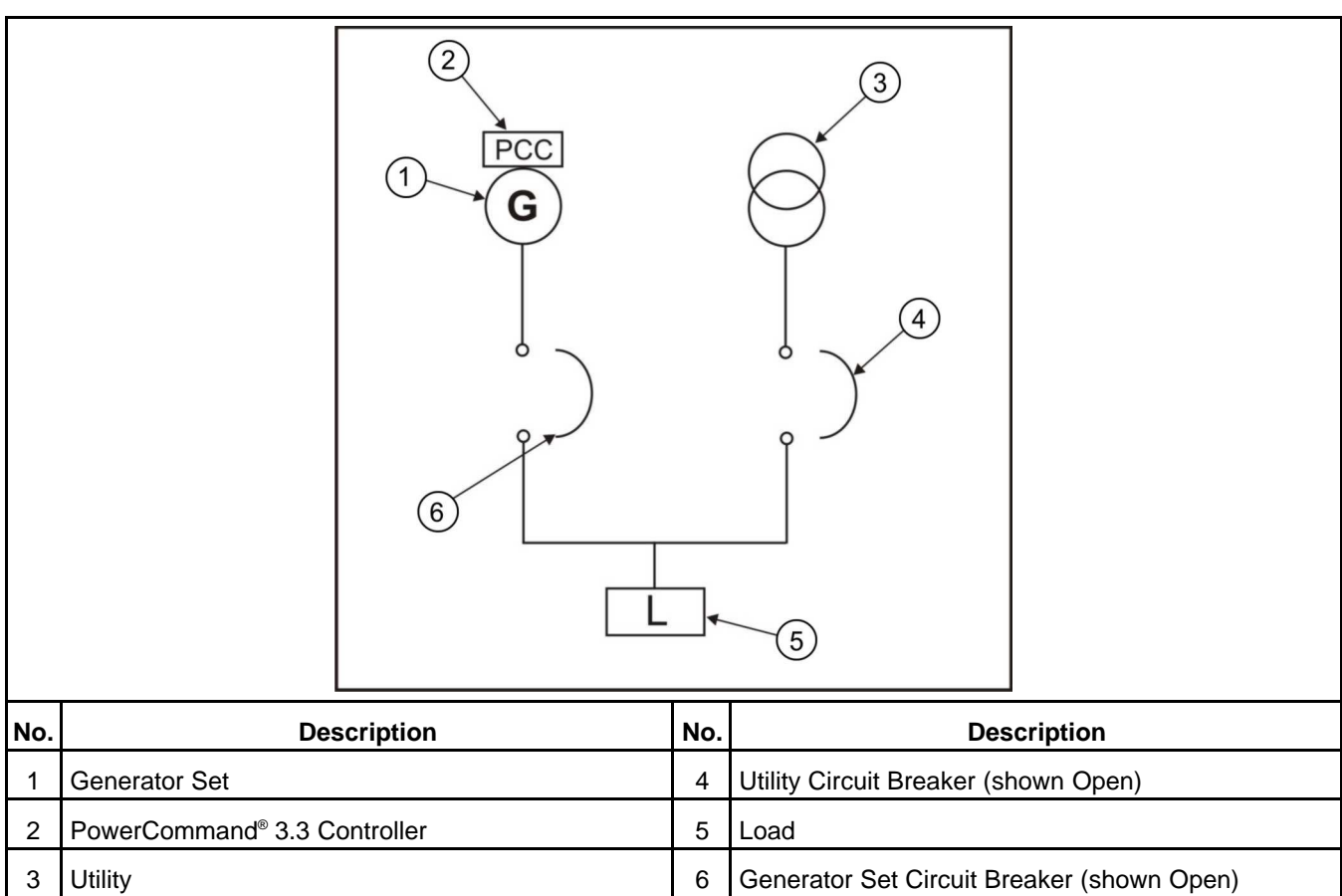

FIGURE 38. MANUAL MODE – CIRCUIT BREAKER CONTROL SEQUENCE 1

Start the generator set in Manual mode. When the generator set is up to speed and voltage, press the circuit breaker Close button to enable the generator set to accept the load.

NOTICE
<i>The PowerCommand® 3.3 control inhibits closure of the paralleling breaker outside the sync-check window. Therefore, the breaker close button can be operated even before synchronization, although the breaker will not close until a signal is sent from the PowerCommand® 3.3 control to allow it.</i>

In [Figure 39 on page 101](#), the generator set’s circuit breaker is open while the utility circuit breaker is closed and is therefore accepting the load.

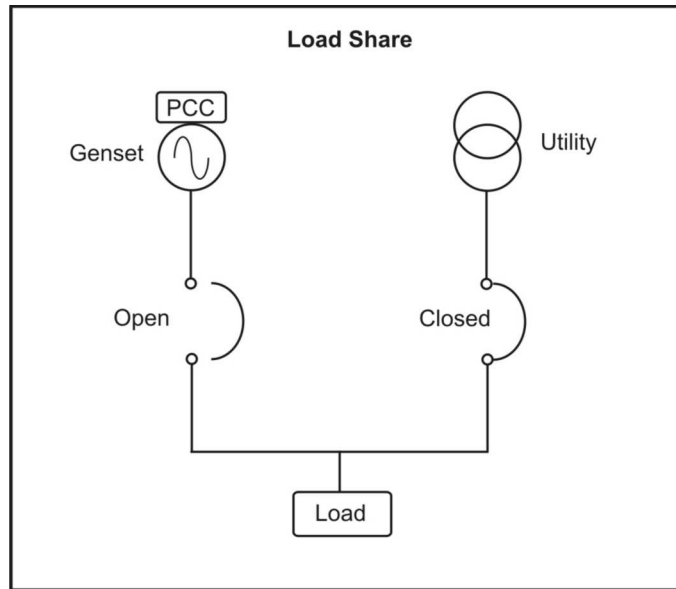

FIGURE 39. MANUAL MODE – CIRCUIT BREAKER CONTROL SEQUENCE 2

The generator's circuit breaker remains open while the utility circuit breaker is closed. The generator is running and the load is receiving power from the utility only. In this condition, the Transition Type must be set to hard or soft closed and the generator and utility must be fully synchronized.

NOTICE

Synchronization requires the Sync Enable signal to be present; otherwise, the PowerCommand® 3.3 control does not automatically synchronize the generator and the utility together.

To progress further, the generator set circuit breaker closed button must be pressed. This will enable the generator set to load share with the utility.

In [Figure 40 on page 101](#), the generator set's circuit breaker is closed and the utility circuit breaker is open. The load in this instance is receiving power from the generator set only.

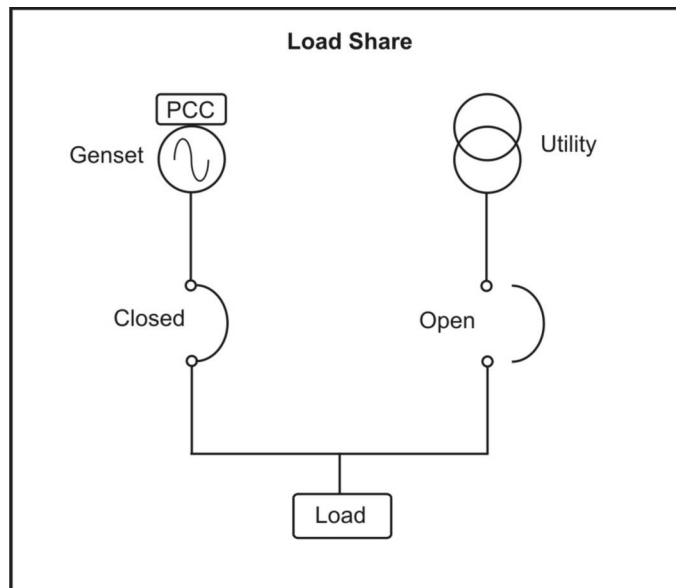

FIGURE 40. MANUAL MODE – CIRCUIT BREAKER CONTROL SEQUENCE 3

When the utility is again providing power, the utility circuit breaker can be closed.

In [Figure 41 on page 102](#), both generator set and utility are providing power for the load.

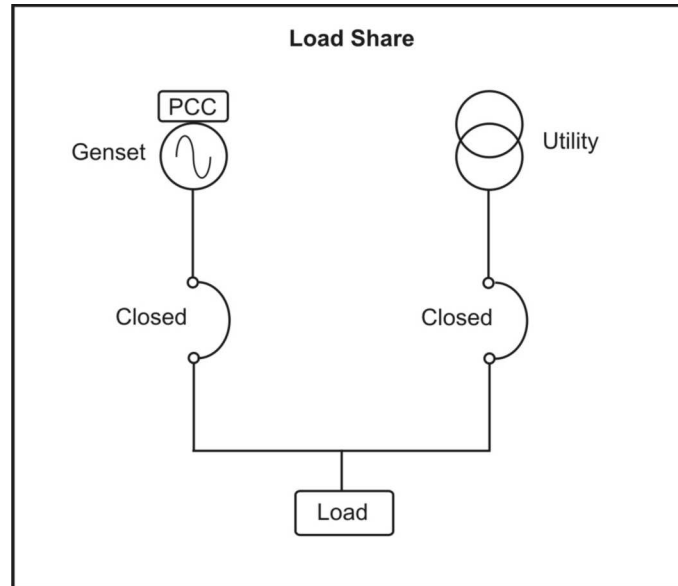

FIGURE 41. MANUAL MODE – CIRCUIT BREAKER CONTROL SEQUENCE 4

In this condition, the PowerCommand® 3.3 control is in the Load Govern paralleling state; both the generator and utility circuit breakers are closed, so the load is now receiving power from both sources. In this condition, the Transition Type is set to Open Transition and the Maximum Parallel Time (TDMO) has expired.

The Power Transfer menu also indicates if either/both utility and the generator set are available to accept a load. This will only be allowed if both sources are fully synchronized.

5.9.8 Conditions for Each Paralleling State

5.9.8.1 Utility Single

In this application, the generator set is running in parallel with the utility. There are no other generator sets employed in this type of system.

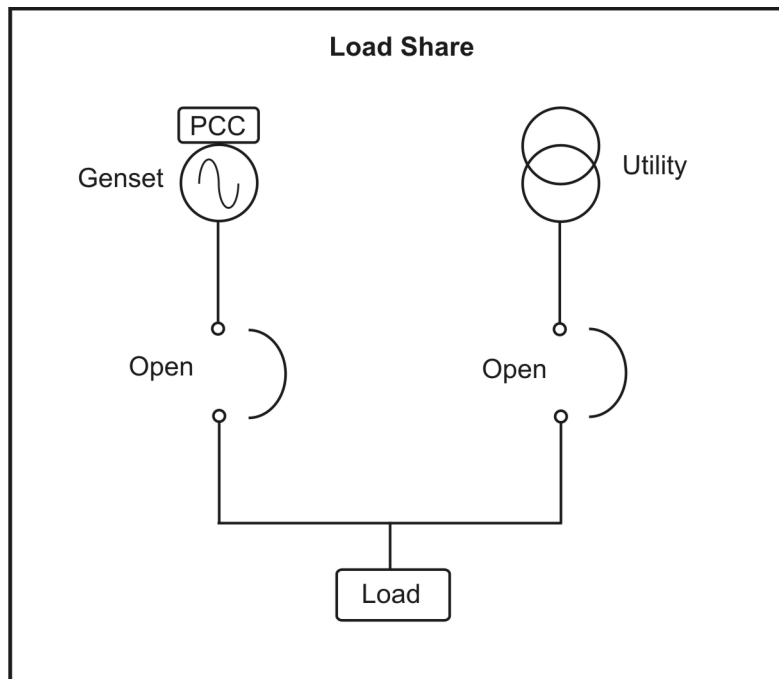

FIGURE 42. UTILITY - SINGLE MODE

The generator set is in the Standby paralleling state until event 1465 (Ready to Load) is active. The controller then considers the current position of both the generator set and the utility circuit breakers, as illustrated in [Figure 42 on page 103](#).

[Figure 43 on page 104](#), [Figure 44 on page 105](#), [Figure 45 on page 106](#) and [Figure 46 on page 107](#) illustrate the various conditions for each paralleling state.

NOTICE

In the following sequences, the PowerCommand® 3.3 control must be in the Standby Paralleling state unless otherwise stated and assumes that the PowerCommand® 3.3 control menus have been set with the correct paralleling parameters.

In [Figure 43 on page 104](#), the circuit breakers on both the generator set and utility are open. The generator set is running and power from the utility is available. In this condition, the load is receiving no power from either source.

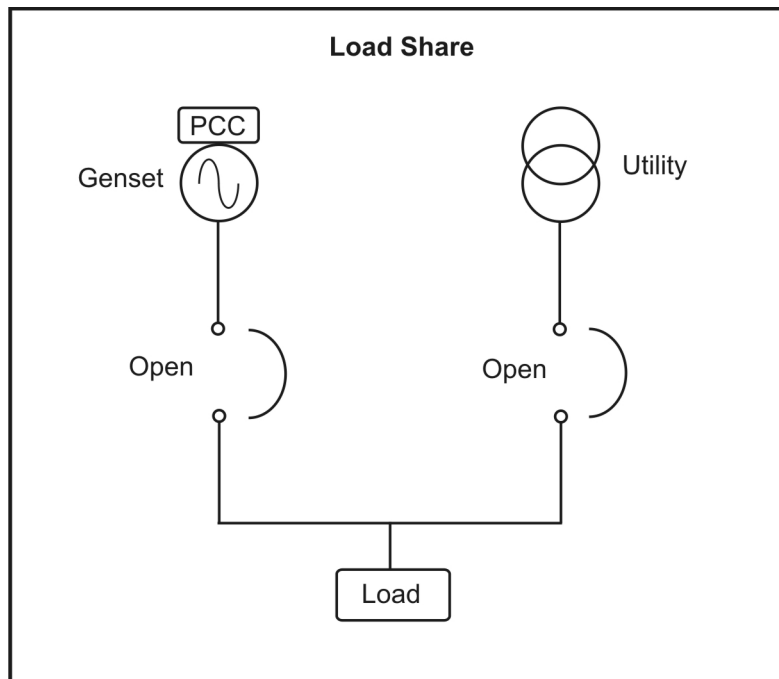

FIGURE 43. UTILITY SINGLE – SEQUENCE 1

Before the PowerCommand® 3.3 control closes the generator set circuit breaker, all of the following conditions must be met:

- There is a generator set circuit breaker Close request.
- There are no generator set circuit breaker Open requests.
- Utility Single Mode Verify/Configurable Input #29 Function Pointer is set to Default.
- Configurable Input #29 is active.

If the PowerCommand® 3.3 control is in Manual mode, the circuit breaker **Close** button must be pressed.

The generator set will then provide power for the load.

NOTICE

The PowerCommand® 3.3 control inhibits closure of the paralleling breaker outside the sync-check window. Therefore, the breaker close button can be operated even before synchronization, although the breaker will not close until a signal is sent from the PowerCommand® 3.3 control to allow it.

In [Figure 44 on page 105](#), the generator set is running with the circuit breaker open and the utility circuit breaker closed, providing power for the load.

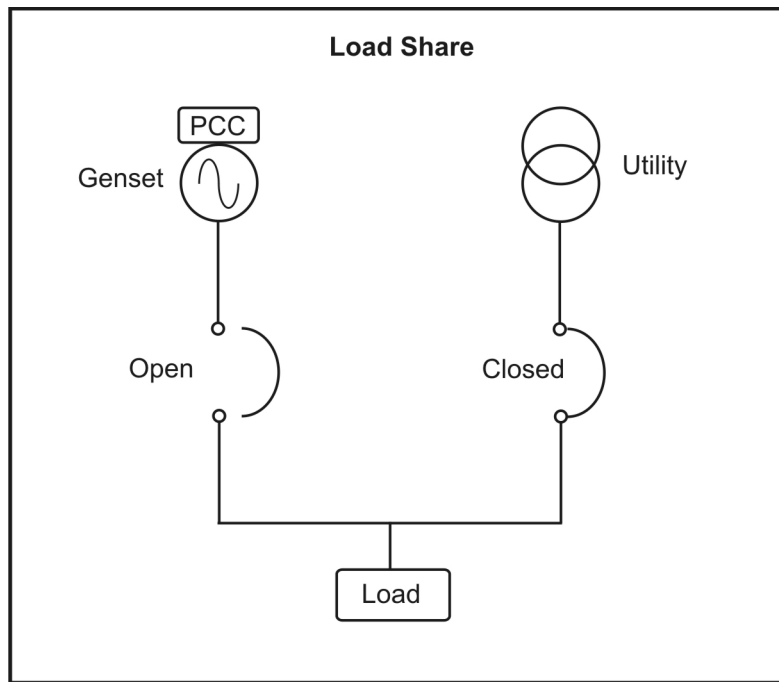

FIGURE 44. UTILITY SINGLE – SEQUENCE 2

The PowerCommand® 3.3 control automatically initiates the Synchronize procedure, since it is synchronizing to the utility.

Before the PowerCommand® 3.3 control closes the generator set circuit breaker, both of the following conditions must be met:

- There are no generator set circuit breaker Open requests.
- There is a generator set circuit breaker Close request.

If the PowerCommand® 3.3 control is in Manual mode, the circuit breaker **Close** button must be pressed. The generator set will then load share with the utility.

In [Figure 45 on page 106](#), the utility circuit breaker is open and the generator set is running with the circuit breaker closed, providing power for the load.

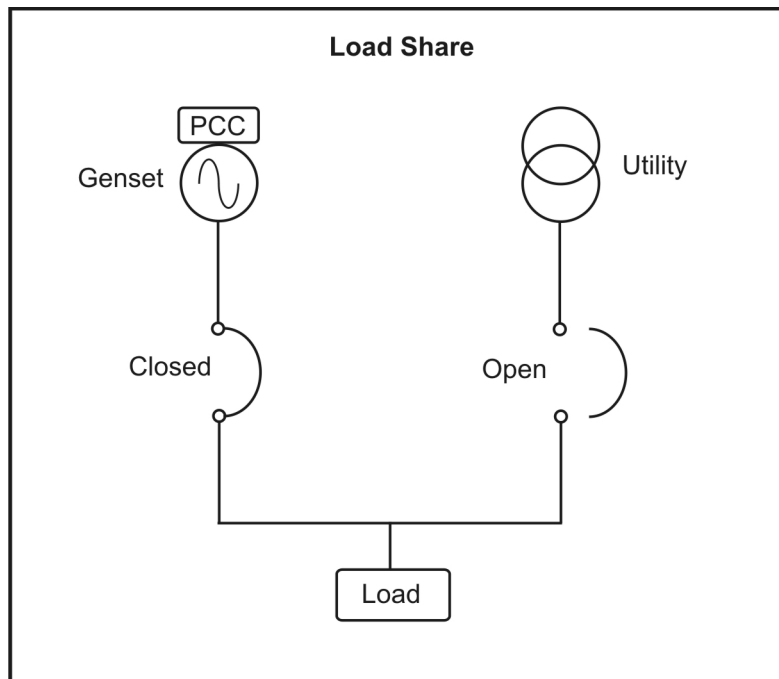

FIGURE 45. UTILITY SINGLE – SEQUENCE 3

When the utility is available, its circuit breaker may be closed and therefore available to supply power to the load. The generator set circuit breaker may then be opened, returning the generator set to the Standby paralleling state. The generator set will therefore no longer supply power to the load.

The Sync Enable input must be closed to enable the synchronizer, thereby allowing a re-transfer of load back to the utility.

NOTICE

Utility CB sync check and utility breaker controls are not part of the PowerCommand@3.3 control system.

NOTICE

In Manual mode, it will be necessary to press the CB Open button on the operator panel.

In this condition (see [Figure 46 on page 107](#)), the PowerCommand® 3.3 control is now in the Load Govern paralleling state. Both the generator set and utility circuit breakers are closed; therefore, the load is now receiving power from both sources.

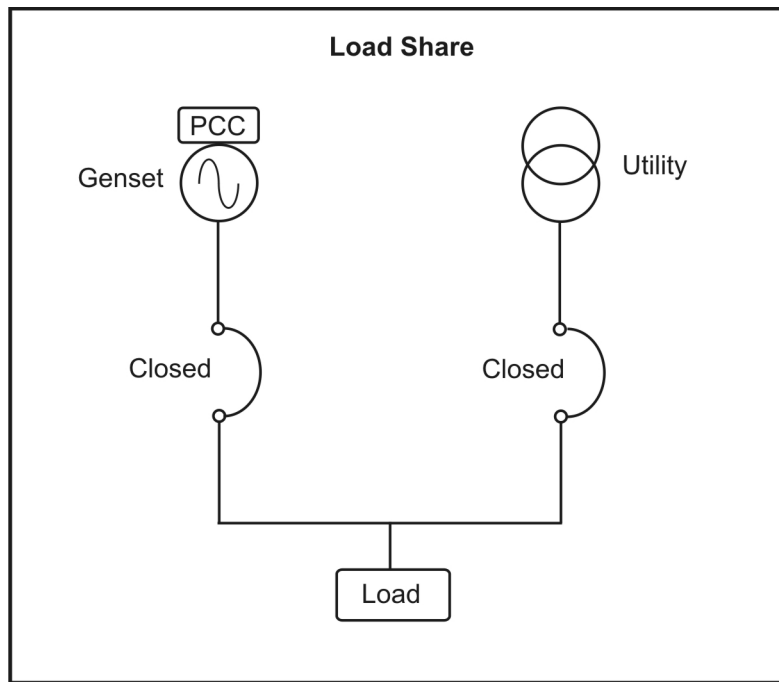

FIGURE 46. UTILITY SINGLE – SEQUENCE 4

Open the generator set circuit breaker if there are any generator set circuit breaker Open requests.

5.9.8.2 Utility Multiple

NOTICE

For paralleling with a PC 3.3 Controller and Motorised Circuit Breaker, to avoid false tripping of the circuit breaker it is recommended to switch off the earth fault protection. The earth fault protection switch is located on the control panel.

In the generator set application shown in [Figure 47 on page 108](#), the generator set is running in parallel with other generator sets which in turn are running in parallel with the utility.

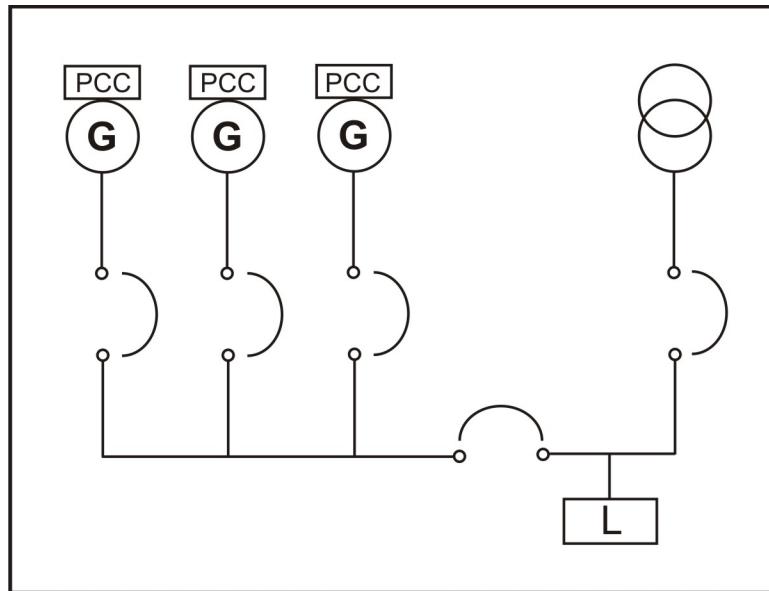

FIGURE 47. UTILITY MULTIPLE

The PowerCommand® 3.3 control is in the Standby paralleling state until Event 1465 (Ready to Load) is active. The PowerCommand® 3.3 control then considers the current position of the generator set circuit breaker and the utility circuit breaker, as illustrated in [Figure 47 on page 108](#). To ensure a seamless transfer of the load between the utility and generator set(s), a closed transition transfer switch is incorporated.

The generator sets may be in Auto or Manual setup. If in Auto setup, the First Start process will be available to enable a generator set to close the circuit breaker onto a dead bus. The remaining generator sets then wait for the bus to go live before synchronizing to it.

[Figure 48 on page 109](#), [Figure 49 on page 110](#), [Figure 50 on page 110](#) and [Figure 51 on page 111](#) illustrate the various conditions for each paralleling state.

NOTICE

In the following sequences, the PowerCommand® 3.3 control must be in the Standby Paralleling State unless otherwise stated and assumes that the PowerCommand® 3.3 control menus have been set with the correct paralleling parameters.

In [Figure 48 on page 109](#), the circuit breakers on both the generator set and utility are open. The generator set is running and power from the utility is available. In this condition the load is receiving no power from either source.

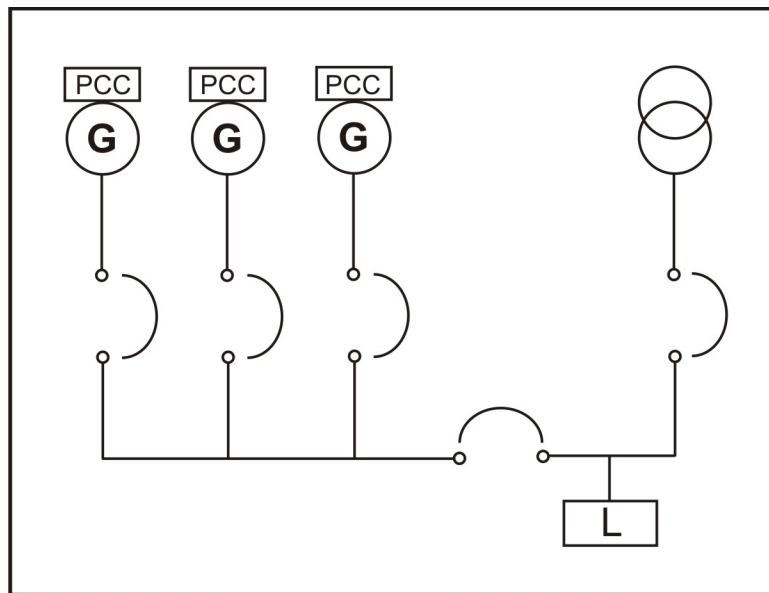

FIGURE 48. UTILITY MULTIPLE – SEQUENCE 1

Before the PowerCommand® 3.3 control closes the generator set circuit breaker, all of the following conditions must be met:

- Initially the First Start process determines whether or not to close the generator set circuit breaker onto a dead bus when it is in parallel with other generator sets (provided the sets are in Auto setup).
- The generator set circuit breaker is then closed if the following conditions are met:
 1. There are no generator set circuit breaker Open requests.
 2. There is a generator set circuit breaker Close request.

If the PowerCommand® 3.3 control is in Manual mode, the circuit breaker **Close** button must be pressed.

NOTICE

The PowerCommand® 3.3 control inhibits closure of the paralleling breaker outside the sync-check window. Therefore, the breaker close button can be operated even before synchronization, although the breaker will not close until a signal is sent from the PowerCommand® 3.3 control to allow it.

When all the above conditions are met and the generator set circuit breaker is closed, the generator set will parallel with the other generator sets and/or the utility to share the load.

In [Figure 49 on page 110](#), the generator set is running with the circuit breaker open and the utility circuit breaker closed, providing power for the load.

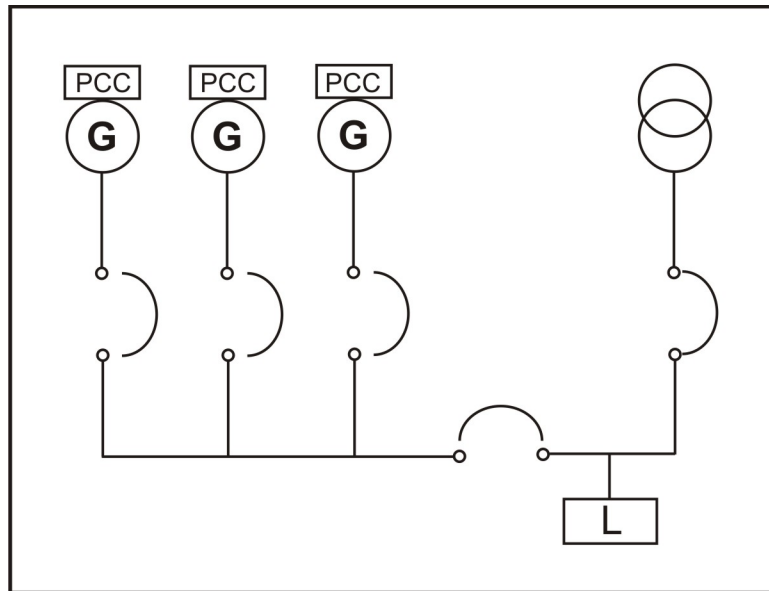

FIGURE 49. UTILITY MULTIPLE – SEQUENCE 2

The PowerCommand® 3.3 control will automatically initiate the Synchronize procedure since it is synchronizing to the utility.

Before the PowerCommand® 3.3 control closes the generator set circuit breaker, all of the following conditions must be met:

- There are no generator set circuit breaker Open requests.
- There is a generator set circuit breaker Close request.

If the PowerCommand® 3.3 control is in Manual mode, the circuit breaker **Close** button must be pressed. The generator set will then load share with the utility.

In [Figure 50 on page 110](#), the utility circuit breaker is open and a generator set is running with the circuit breaker closed, providing power for the load.

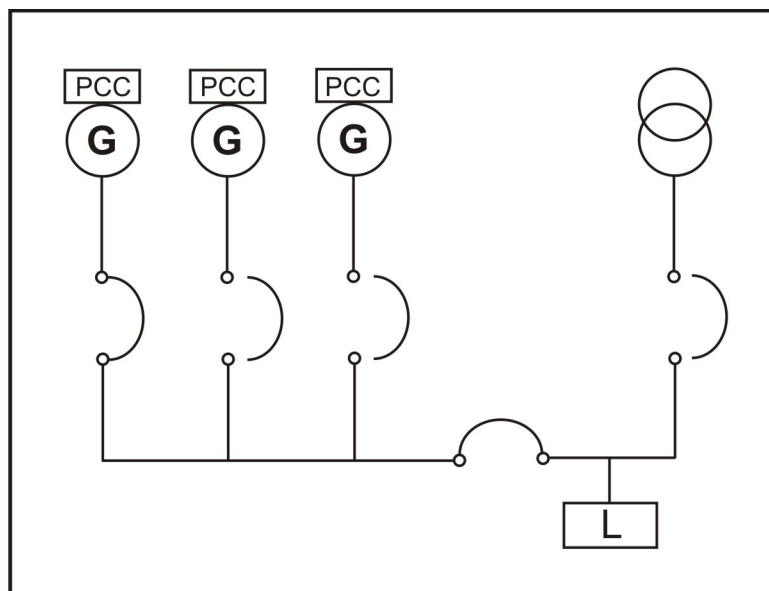

FIGURE 50. UTILITY MULTIPLE - SEQUENCE 3

When the utility is again available to supply the load, open the generator set circuit breaker if there are any generator set circuit breaker Open requests. This will place the generator set back into the Standby paralleling state and therefore will no longer supply power to the load.

In [Figure 51 on page 111](#), the PowerCommand® 3.3 control is now in the Load Govern paralleling state. Both the generator set and utility circuit breakers are closed, so the load is now receiving power from both sources.

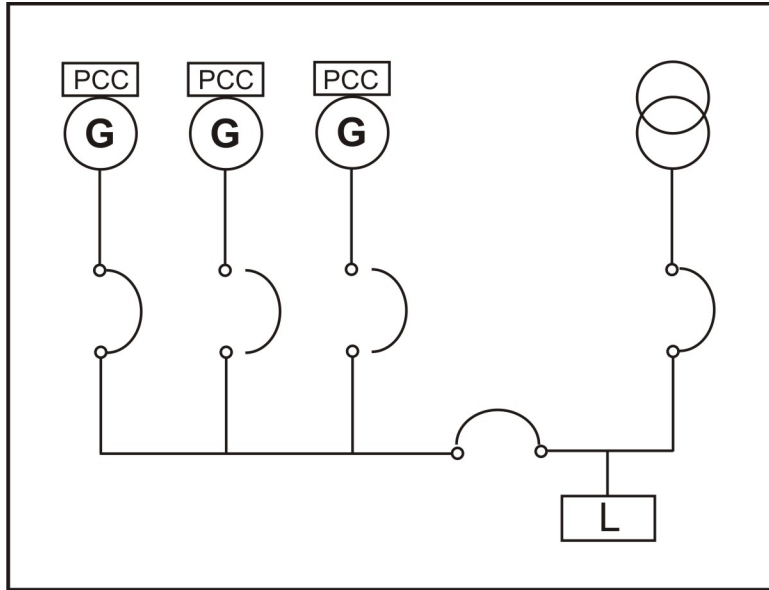

FIGURE 51. UTILITY MULTIPLE - SEQUENCE 4

Open the generator set circuit breaker if there are any generator set circuit breaker Open requests. This will place the generator set back into the Standby paralleling state and therefore will no longer supply power to the load.

This page is intentionally blank.

6 Maintenance

WARNING

Automated Machinery

Accidental or remote starting of the generator set can cause severe personal injury or death. Make sure that the generator set cannot be started accidentally or remotely before starting work on the generator.

WARNING

Fall Hazard

Falls can result in severe personal injury or death. Make sure that suitable equipment for performing tasks at height are used in accordance with local guidelines and legislation.

WARNING

Mechanical Hazard

Failed components may be ejected or operate incorrectly which can cause severe personal injury or death. Do not climb the generator set; this may damage critical parts.

WARNING

Combustible Gases

Ignition of battery gases is a fire and explosion hazard which can cause severe personal injury or death. Do not smoke, or switch the trouble light ON or OFF near a battery. Touch a grounded metal surface first before touching batteries to discharge static electricity. Stop the generator set and disconnect the battery charger before disconnecting battery cables. Using an insulated wrench, disconnect the negative (-) cable first and reconnect it last.

WARNING

Electric Shock Hazard

Voltages and currents present an electrical shock hazard that can cause severe burns or death. Make sure that only personnel who are trained and experienced work with distribution voltages. Even after generator set shutdown, an electrical shock hazard may still exist, caused by induced or residual voltage within the alternator or cables. Some interfaces may display zero voltage even when voltages are present.

WARNING

Electrical Generating Equipment

Incorrect operation and maintenance can result in severe personal injury or death. Make sure that only suitably trained and experienced service personnel perform electrical and/or mechanical service.

NOTICE

Only authorized and qualified maintenance technicians, who are familiar with the equipment and its operation, should carry out maintenance.

NOTICE

Dependent upon the control system fitted, this unit may operate automatically and could start without warning.

NOTICE

Before carrying out any maintenance work, become familiar with [Section 1.3 on page 5](#), together with all the documentation supplied with the generator set.

NOTICE

Always disconnect a battery charger from its AC source before disconnecting the battery cables. Failure to do so can result in voltage spikes high enough to damage the DC control circuits of the generator set.

All maintenance tasks must be assessed for health and safety risks, the preventative measures identified must be actioned. Accompaniment is required for tasks where the presence of someone else will add significantly to the safety of the task.

Read, understand, and comply with all *Caution and Warning Notes* in this section, those contained within [Chapter 1](#), and those contained within the documentation supplied with the generator set.

Ensure adequate lighting and staging (where required) are installed.

NOTICE

Before carrying out any maintenance work, lock the generator set out of service for safe working.

6.1 Locking the Generator Set Out of Service

Before any work is carried out for maintenance, etc., the generator set must be immobilized. Even if the generator set is put out of service by pressing the **Off** switch on the operator panel, the generator set cannot be considered safe to work on until the engine is properly immobilized, as detailed in the following procedures.

NOTICE

Refer also to the engine specific Operator Manual. This manual contains specific equipment instructions that may differ from the standard generator set.

6.1.1 Immobilizing for Safe Working

To immobilize the generator set:

1. Press the **Off** mode switch on the operator panel to shut down the generator set.
2. Press the **Emergency Stop** button. This prevents the generator set starting, regardless of the Start signal source and provides an additional safety step for immobilizing the generator set.

NOTICE

When the Emergency Stop button is pressed, the operator panel indicates a Shutdown condition. The red Shutdown status LED  illuminates and a message is displayed.

NOTICE

Do not cover Emergency stop button in any situation for easy accessibility

NOTICE

This condition is stored in the Fault History.

3. Isolate and lock off the starting battery/batteries.
4. As an additional precaution, thoroughly ventilate the plant room before disconnecting any leads.
5. Isolate and lock off the supply to the heater, where fitted.
6. Isolate and lock off the supply to the battery charger, where fitted.
7. Isolate the fuel supply to the engine.
8. Using an insulated wrench, disconnect the negative (-) cable first on the starting batteries and control system batteries (if separate).
9. Fit warning notices at each of the above points to indicate Maintenance in Progress — Plant Immobilized for Safe Working.

This page is intentionally blank.

7 Periodic Maintenance

The periodic maintenance procedures should be performed at whichever interval occurs first. At each scheduled maintenance interval, perform all previous maintenance checks that are due for scheduled maintenance.

The tabular data that follows gives the recommended service intervals for a generator set on Standby service. If the generator set will be subjected to Prime usage or extreme operating conditions, the service intervals should be reduced accordingly.

Some of the factors that can affect the maintenance schedule are:

- Use for continuous duty (prime power)
- Extremes in ambient temperature
- Exposure to elements
- Exposure to salt water
- Exposure to windblown dust or sand
- Poor quality of fuel

Consult with an authorized distributor if the generator set will be subjected to any extreme operating conditions and determine if extra protection or a reduction in service intervals is needed. Use the running time meter to keep an accurate log of all service performed for warranty support. Perform all service at the time period indicated, or after the number of operating hours indicated, whichever comes first.

7.1 Periodic Maintenance Schedule

7.1.1 Air Intake Maintenance Schedule

TABLE 20. AIR INTAKE MAINTENANCE

MAINTENANCE ITEMS	Daily 8 Hours	Weekly 50 Hours	6 Months 250 Hours	12 Months 500 Hours	12 Months 1000 Hours	1500 Hours 12 Months	2000 Hours	2 Years 6000 Hours
Perform maintenance tasks as specified using Daily or Hourly periods – whichever occurs first								
Task	Operator Task		Service Technician Task					
Check air cleaner restriction indicator (where fitted): If the service indicator shows red, replace air cleaner elements and reset the air cleaner service indicator.	■							
Check air intake system for leaks: Visually inspect the air intake system for signs of wear or damage. Check audibly when the generator set is running. To replace, contact your authorized distributor.	■							
Replace Air Filter Elements - Normal Duty					■ ¹			

¹ Use this replacement interval or as shown by the air restriction indicator.

7.1.2 Control Maintenance Schedule

TABLE 21. CONTROL MAINTENANCE

MAINTENANCE ITEMS	Daily 8 Hours	Weekly 50 Hours	6 Months 250 Hours	12 Months 500 Hours	1500 Hours 12 Months	2000 Hours	2 Years 6000 Hours
Perform maintenance tasks as specified using Daily or Hourly periods – whichever occurs first							
Task	Operator Task		Service Technician Task				
Check operation of Control Panel: Check display (the system will perform a control panel test on initial activation). To replace, contact your authorized distributor.	■						
Check operation of Emergency Stop Button: With the generator set running, press the Emergency Stop button. Check all systems, before resetting the fault.		■					

7.1.3 Cooling Maintenance Schedule

TABLE 22. COOLING MAINTENANCE

MAINTENANCE ITEMS	Daily 8 Hours	Weekly 50 Hours	6 Months 250 Hours	12 Months 500 Hours	1500 Hours 12 Months	2000 Hours	2 Years 6000 Hours	3 Years
Perform maintenance tasks as specified using Daily or Hourly periods – whichever occurs first								
Task	Operator Task		Service Technician Task					
Check coolant level of radiator(s): If low, top up to coolant system specifications level, with Cummins recommended coolant mix.	■		■					
Check cooling fan blades: Visually inspect the fan blades through the guarding for signs of wear or damage. To replace, contact your authorized distributor.	■		■					
Check drive belt, condition and tension: Visually check belt for evidence of wear or slippage. To replace, contact your authorized distributor.	■		■					
Check coolant lines and radiator hoses for leaks, wear, and cracks: Visually check for leaks, worn or damages hoses. To replace, contact your authorized distributor.	■		■					

MAINTENANCE ITEMS	Daily 8 Hours	Weekly 50 Hours	6 Months 250 Hours	12 Months 500 Hours	1500 Hours 12 Months	2000 Hours	2 Years 6000 Hours	3 Years
Task	Operator Task		Service Technician Task					
Check radiator air flow: Visually inspect the radiator through the guarding for blockage, build up of debris, signs of wear or damage. To clean or replace, contact your authorized distributor.	■							
Check anti-freeze and DCA concentration			■					
Clean radiator core.			■ ¹					
Re-grease bearings			■					
Check water pump.						■		
Change coolant filter.			■					
Check coolant heater.			■					
Fan drive idler arm and fan belt tensioner check.					■			
Replace cooling system coolant.							■	
Pressure test Radiator Pressure Cap.				■				
Replace Radiator Pressure Cap								■
■ ¹ – Cleaning schedule may be reduced depending on operating conditions/environment. Contact your authorized distributor.								

7.1.4 Engine Maintenance Schedule

TABLE 23. ENGINE MAINTENANCE

MAINTENANCE ITEMS	Daily 8 Hours	Weekly 50 Hours	6 Months 250 Hours	6 Months 500 Hours	12 Months 500 Hours	12 Months 1500 Hours	3 Years 500 Hours	2 Years 6000 Hours
Task	Operator Task		Service Technician Task					
Check fuel lines and hoses: Visually check for leaks, worn or damages hoses. To replace, contact your authorized distributor.	■ ¹							
Check engine oil level: If low, top up to engine specifications level, with recommended oil.	■							
Drain water from fuel system primary filter/water separator: Drain one cup, or more, of fuel to remove water and sediment. See procedure in this chapter.	■							

MAINTENANCE ITEMS	Daily 8 Hours	Weekly 50 Hours	6 Months 250 Hours	6 Months 500 Hours	12 Months 500 Hours	12 Months 1500 Hours	3 Years 500 Hours	2 Years 6000 Hours
Perform maintenance tasks as specified using Daily or Hourly periods – whichever occurs first								
Task	Operator Task		Service Technician Task					
Crankcase breather tube/collector. Check for condensed oil. Drain and dispose of in accordance with local legislation.	■							
Check closed crankcase vent (CCV) check the filter service indicator (if equipped).	■			■				
Check charge alternator: Check visually and audibly when the generator set is running. To replace, contact your authorized distributor.	■							
Check engine oil make-up system: If low, top up to indicated level, with Cummins recommended oil.	■							
Check engine coolant heater: Check coolant heater has power and is running. To replace, contact your authorized distributor.	■							
Check all hardware (fittings, clamps, fasteners, etc.)			■					
Replace lubricating oil and filters.					■ 2			
Check engine ground. Clean as necessary.					■			
Replace water separator element.							■	
Replace fuel system secondary filter.							■	
Check engine mounts.					■			
Check starting motor.						■		
Check turbocharger.						■		
Engine oil heater check.						■		
Engine steam clean.						■		
1 – Check before starting and again with the generator set running. 2 – Oil change interval may differ and be up to three years depending on oil grade and fuel sulfur content. Refer to Cummins Bulletin 5677186.								

7.1.5 Exhaust Maintenance Schedule

TABLE 24. EXHAUST MAINTENANCE

MAINTENANCE ITEMS	Daily 8 Hours	Weekly 50 Hours	6 Months 250 Hours	12 Months 500 Hours	1500 Hours 12 Months	2000 Hours	2 Years 6000 Hours
Perform maintenance tasks as specified using Daily or Hourly periods – whichever occurs first							
Task	Operator Task		Service Technician Task				
Check all exhaust components, and hardware (fittings, clamps, fasteners, etc.): Visually inspect the exhaust system for signs of wear or damage. Check audibly when the generator set is running. To replace, contact your authorized distributor.	■						
Check exhaust condensation trap: Drain condensation into a suitable container. Dispose of fluids in accordance with local legislation.	■						

7.1.6 Generator Set Maintenance Schedule

TABLE 25. GENERATOR SET MAINTENANCE

MAINTENANCE ITEMS	Daily 8 Hours	Weekly 50 Hours	6 Months 250 Hours	12 Months 500 Hours	12 Months 1000 Hours	1500 Hours 12 Months	2000 Hours	2 Years 6000 Hours
Perform maintenance tasks as specified using Daily or Hourly periods – whichever occurs first								
Task	Operator Task		Service Technician Task					
Check fuel level in tank: If low, add fuel (A full tank reduces condensation.)	■							
Check bedframe/enclosure fluid containment (where fitted): Drain as necessary. Clean all contaminated areas. Dispose of fluids in accordance with local legislation.	■							
Inspect Engine/Alternator Flexible Rubber Coupling					■			
Check generator set enclosure: Visually check enclosure, walk around inspection of generator set. Make sure no inlets/outlets are covered/restricted, service access doors are operational and safety systems are in place and operational. To replace damaged parts, contact your authorized distributor.	■							

MAINTENANCE ITEMS	Daily 8 Hours	Weekly 50 Hours	6 Months 250 Hours	12 Months 500 Hours	12 Months 1000 Hours	1500 Hours 12 Months	2000 Hours	2 Years 6000 Hours
Perform maintenance tasks as specified using Daily or Hourly periods – whichever occurs first								
Task	Operator Task		Service Technician Task					
Check batteries: Check connections are secure and battery area is free from tools and other items.		■				■		
Check battery electrolyte level.				■				
Check electrical connections (battery, starter motor and alternator connections).				■		■		
Check power cable connections going in and out of main circuit breaker. Make sure the connections are all tight and torque to specifications if required.				■				

7.1.7 Alternator Service Schedule

TABLE 26. ALTERNATOR SERVICE SCHEDULE

System	SERVICE ACTIVITY X = required * = if necessary	Alternator running	TYPE				SERVICE LEVEL								
			Inspect	Test	Clean	Refill/Replace	Commission	Post Commission	250 hrs / 0.5 year	Level 1	1000 hrs / 1 year	Level 2	10,000 hrs / 2 years	Level 3	30,000 hrs / 5 years
Alternator	Alternator rating		X				X								
	Bedplate arrangement		X				X								
	Coupling arrangement		X				X				*		X		
	Environmental conditions and cleanliness		X				X	X		X		X		X	
	Ambient temperature (inside & outside)			X			X	X		X		X		X	
	Complete machine - damage, loose parts & earth bonds		X				X	X		X		X		X	
	Guards, screens, warning and safety labels		X				X	X		X		X		X	
	Maintenance access		X				X								
	Electrical nominal operating conditions & excitation	X		X			X	X		X		X		X	
	Vibration	X		X			X	X		X		X		X	
Windings	Condition of windings		X				X	X		X		X		X	
	Insulation resistance of all windings (PI test for MV/HV)			X			X	*		*		X		X	
	Insulation resistance of rotor, exciter and PMG			X				X		X					
	Temperature sensors	X		X			X	X		X		X		X	
	Customer settings for temperature sensors		X				X								

System	SERVICE ACTIVITY X = required * = if necessary	Alternator running	TYPE				SERVICE LEVEL							
			Inspect	Test	Clean	Refill/Replace	Commission	Post Commission	250 hrs / 0.5 year	Level 1	1000 hrs / 1 year	Level 2	10,000 hrs / 2 years	Level 3
Bearings	Condition of bearings		X				X							X
	Grease exhaust & trap				X			every 3000 to 3500 hours / 6 months						
	Re-grease bearing(s) (A to H core length)	X				X		every 3000 to 3500 hours / 6 months						
	Replace re-greasable bearing(s)					X					*		X	
	Temperature sensors	X		X			X	X	X	X	X	X		
	Customer settings for temperature sensors		X				X							
Terminal Box	All alternator/customer connections and cabling		X				X	X	X	X	X	X		
Controls & Auxiliaries	Initial AVR & PFC set up	X		X			X							
	AVR & PFC settings	X		X				X	X	X	X	X		
	Customer connection of auxiliaries			X			X		X	X	X	X		
	Function of auxiliaries			X			X	X	X	X	X	X		
	Synchronization settings		X				X							
	Synchronization	X		X			X	X	X	X	X	X		
	Anti condensation heater					X					*	X		
Rectifier	Diodes and varistors		X				X	X	X	X	X			
	Diodes and varistors					X						X		
Cooling	Air inlet temperature	X		X			X	X	X	X	X	X		
	Air flow (rate & direction)	X	X				X							
	Condition of fan		X				X	X	X	X	X	X		
	Condition of air filter (where fitted)			X			X	X	X	X	X	X		
	Air filters (where fitted)				X	X			*	*	*	*		

7.2 Generator Set Long Term Storage

7.2.1 Required Materials

- Tectyl™ 915W40 or equivalent engine preservative oil that meets military specification MIL-PRF-21260, type P-10, Grade 2, SAE 30
- Tectyl™ 511-M, or equivalent rust preventative compound that meets military specification MIL-C-16173C, type P-2, Grade 1 or 2
- Daubert Chemical NoxRust No. 518 or equivalent preservative oil that meets military specification MIL-L-644, type P-9
- Moisture indicating silica desiccant gel packs
- Heavy paper or plastic and tape
- Corrosion inhibiting plastic such as Zerust

NOTICE

Do not leave Bio-Free diesel fuel in the fuel system longer than 6 months.

NOTICE

Do not leave diesel fuel containing bio components in the fuel system during storage. Fuel properties degradation may cause damages and lead to premature failure of fuel system components.

7.2.2 Procedure

⚠ WARNING

Hot Pressurized Liquid

Contact with hot liquid can cause severe burns.

Do not open the pressure cap while the engine is running. Let the engine cool down before removing the cap. Turn the cap slowly and do not open it fully until the pressure has been relieved.

⚠ WARNING

Moving Parts

Moving parts can cause severe personal injury.

Use extreme caution around moving parts. All guards must be properly fastened to prevent unintended contact.

⚠ WARNING

Persons working close to the generator during lightning risk receiving an electric shock.

⚠ WARNING

High Noise Level

Generator sets in operation emit noise, which can cause hearing damage.

Wear appropriate ear protection at all times.

⚠ WARNING**Hot Surfaces**

Contact with hot surfaces can cause severe burns.

Wear appropriate PPE when working on hot equipment and avoid physical contact with hot surfaces.

NOTICE

Keep multi-class ABC fire extinguishers handy. Class A fires involve ordinary combustible materials such as wood and cloth. Class B fires involve combustible and flammable liquid fuels and gaseous fuels. Class C fires involve live electrical equipment. (Refer to NFPA No. 10 in applicable region.)

NOTICE

Failure to follow these instructions may invalidate the warranty and may result in reduced reliability. Please contact your local factory representative for more details.

1. Follow the proper starting procedure to start the generator set.
2. Bring the generator set to rated speed with no load.
3. Operate the generator set until the coolant temperature reaches 160° F (70° C).
4. Follow the proper procedure to turn off the generator set.
5. Follow the necessary lock-out-tag-out procedures to ensure the generator does not start.
6. Drain the engine oil from the oil sump.
7. Install the drain plug and fill the engine to the high mark with the Tectyl™ 915W40, or equivalent engine preservative oil.
8. Disconnect the inlet fuel line to the engine fuel filter.
9. Disconnect the injector fuel return line.

NOTICE

Refer to the fuel consumption specifications to determine the amount of fuel required to run the engine for 25 minutes.

10. Put both fuel lines in the container of bio-free diesel fuel.
11. Follow the proper starting procedure to start the generator set.
12. Once the engine is operating smoothly, transfer the fuel supply line to the container of the Daubert Chemical NoxRust No. 518 or equivalent preservative oil outlined in the **Required Materials Section**.
13. Operate the generator at idle for 25 minutes to ensure the engine preservative oil and the fuel system preservative is fully distributed.

NOTICE

Dispose of the mixed fuel in accordance with local regulations.

14. Follow the proper procedure to turn off the generator set.
15. Follow the necessary lock-out-tag-out procedures to ensure the generator set does not start.

16. Re-connect both fuel lines.
17. Drain the preservative oil from the engine oil pan sump, oil filter and fuel filters.
18. Install the drain plug in the oil sump. The sump can remain empty until the engine is ready to put in a service application.
19. Remove the intake and exhaust manifolds.
20. Spray Tectyl™ 511-M or equivalent into the intake and exhaust ports in the cylinder heads and in the manifolds.

NOTICE

Do NOT spray Tectyl™ 511-M or equivalent preservative oil on the intake manifold or any fuel system components as this may permanently damage sensors or valves.

21. Brush or spray Tectyl™ 511-M or equivalent on all the exposed surfaces that are not painted. Preservative oil should not be applied to any plastic, rubber or similar surfaces. Make sure to coat the flywheel, flywheel housing and all other unpainted machined surfaces with this preservative oil.
22. Remove the rocker lever covers.
23. Spray Tectyl™ 511-M or equivalent onto the rocker levers, valve stems, springs, valve guides, crossheads and push rods.
24. Install the covers.
25. Remove camshaft inspection covers.
26. Spray Tectyl™ 511-M or equivalent onto the camshaft.
27. Install the covers.
28. For components containing exposed bearings that are not easily accessible (e.g. fan hubs), remove the component to aid access. Brush or spray Tectyl™ 511-M or equivalent on all surfaces that are not painted and refit the component.
29. Remove any external drive belts to prevent localized stretching and deformation.
30. If the generator set will remain in storage for 24 months or more, the cooling system must be drained.

NOTICE

If the storage period will be less than 24 months, and if it meets Cummins coolant specifications for anti-freeze with anti-corrosion inhibitor, then it is not necessary to drain the coolant.

NOTICE

The engine cooling system must be drained and flushed with a suitable solvent or a hot, lightweight mineral oil after each 24-month period.

31. Place a warning tag on the generator stating "Engine Does NOT Contain Oil" and "Do NOT Operate."
32. Store the generator set in a clean, dry, vibration free and climate controlled area.
33. Place silicon gel packs in the following areas.
 - Generator control panel
 - Intake manifold

- Exhaust manifold

7.2.3 Additional Steps

NOTICE

For two bearing alternators, decouple the alternator from the engine. For single bearing machines, do not decouple.

NOTICE

Do not rotate the engine during long term storage.

NOTICE

If the two bearing alternator is decoupled, rotate only the alternator 6 complete revolutions every 4 weeks. For single bearing machines, do not rotate

- Leave the alternator anti-condensation heaters in operation. If power to the heaters is unavailable, then place multiple silica desiccant gel packs in the core of the alternator at both ends of the rotor and in the terminal box.
- Place multiple silica desiccant gel packs on the outside of the generator at, or near the following areas:
 - Intake/exhaust manifolds
 - Generator set control panel
 - ECM's
 - Alternator entrance box

NOTICE

The amount of silica desiccant gel packs required and the replacement interval for the silica gel packs will vary based on manufacturer and the environment the generator is exposed to. Follow manufacturer guidelines for replacement intervals and to determine the amount needed. Moisture indicating gel packs will better determine when the replacements need to occur. Inspect the silica gel packs once a month.

- If necessary, disconnect the generator set batteries. Follow the manufacturer's storage procedures to store the batteries.
- Cover all openings with heavy paper or plastic and tape to prevent dirt and moisture from entering the engine/alternator.
- Place a warning tag on the generator set stating there are silica desiccant gel packs at the locations placed.
- Wrap the generator set in a corrosion inhibiting plastic such as Zerust.

7.2.4 Returning the Generator Set to Service

1. Remove the protective paper and plastic coverings.
2. Remove all silica desiccant gel packs.

3. For alternators with re-greasable bearings:
 - If the alternator has been rotated during the storage period and has been in storage between 6 and 24 months, re-grease the bearings during the first run. Follow the recommended re-greasing procedure found in the specific alternator service manual.
 - If the alternator has not been rotated during the storage period and has been in storage for a period longer than 12 months, replace the bearings. Follow the recommended re-replacement procedure found in the specific alternator service manual.
4. For alternators with sealed for life bearings:
 - If the alternator has been rotated during the storage period and has been in storage for a period longer than 24 months, replace the bearings. Follow the recommended replacement procedure found in the specific alternator service manual.
 - If the alternator has not been rotated during the storage period and has been in storage for a period longer than 12 months, replace the bearings. Follow the recommended replacement procedure found in the specific alternator service manual.
5. For two bearing machines, recouple the alternator to the engine if necessary.
6. For the alternator, carry out the "pre-running" checks as detailed in the specific alternator model service manual to determine the condition of the windings.
7. Flush the engine preservative oil out of the engine by removing the plug from the main engine oil rifle and pumping a hot, lightweight mineral oil through it. Make sure that the engine crankshaft is barred at least 3 to 4 revolutions during this flushing procedure.
8. Drain all the mineral oil that was used to flush the engine clean and the engine preservative oil.
9. Install the drain plugs.
10. If necessary fill or flush/fill the cooling system:
 - If the generator set has been in storage for less than 24 months and if the cooling system was drained, fill the cooling system with new coolant.
 - If the generator set has been in storage for 24 months or more, the cooling system must be drained and flushed with a suitable solvent or a hot, lightweight mineral oil.
 - If the generator set has been in storage for less than 24 months and the cooling system has an extended life coolant with a rust inhibitor, then drain and fill the cooling system with new coolant.
11. Fill and install new oil, fuel and coolant filters.
12. Fill the oil pan sump.
13. If necessary, re-connect the generator set batteries.
14. Prime the lubricating system using the main oil rifles of the engine.
15. Reinstall any belts that were removed.

NOTICE

The engine may run unstable until the fuel system is completely primed, or until the preservative fluid is completely flushed out of the fuel system.

7.3 Maintenance Procedures - Daily or When Refueling

Monitor fluid levels, oil pressure, and coolant temperature frequently. During operation, be alert for mechanical problems that could create unsafe or hazardous conditions. The following sections cover several areas that should be frequently inspected for continued safe operation.

NOTICE

Components that have guards against inadvertent touching must be visually inspected only. Do not remove the guards to do the inspection.

7.3.1 General Information

Preventive maintenance begins with day-to-day awareness of the condition of the generator set. Before starting the generator set, check and look for:

- Oil and coolant levels
- Leaks
- Loose or damaged parts
- Worn or damaged belts
- Any change in engine noise or performance
- Generator set appearance

7.3.2 Engine Operation Report

The engine must be maintained in good mechanical condition if the operator is to obtain optimum satisfaction from its use. Running reports are necessary to enable programmed or emergency servicing to be carried out.

Comparison and intelligent interpretation of the running report, together with a practical follow-up action will eliminate most failures and emergency repairs.

Most engine problems give an early warning. Look and listen for changes in engine performance, sound, or appearance that can indicate service or repair is needed. Some engine changes to look for and report on are:

- Low lubricating oil pressure
- Low power
- Abnormal water or oil temperature
- Unusual engine noise
- Excessive use of coolant, fuel or lubricating oil
- Any coolant, fuel, or lubricating oil leaks
- Misfire
- Unexplained frequency fluctuation
- Significant vibration
- Excessive white and/or black exhaust smoke.

7.4 Cooling System

NOTICE

Loss of coolant can allow the engine to overheat if it does not have the protection of a shutdown device. This can cause severe damage to the engine. Maintain coolant level for proper operation of high engine temperature shutdown system. If applicable, see the *Model Specifications* section for more information.

7.4.1 Water Quality Check

Excessive levels of calcium and magnesium contribute to scaling problems, and excessive levels of chloride and sulfate cause cooling system corrosion. If water quality is unknown, it can be tested with the Fleetguard® Monitor C™ program or Water-Chek™ test strip. Water test results can also be obtained from local water utility departments. Test data must show the following elements, and the levels must not exceed the published limits for use in cooling systems.

Calcium, Magnesium (Hardness) Maximum level 170 ppm (as CaCO₃)

Chloride 40 ppm (as Cl)

Sulfate 100 ppm (as SO₄)

Fleetguard® Water-Chek™ Test Strip, Part Number CC2609, can be used to determine the quality of make-up and shop tap water. The Water-Chek™ test strip measures hardness, pH, and chloride levels in make-up water.

For additional information or advice refer to your local distributor.

7.4.2 Coolant Level Check - Introduction

⚠ WARNING

Fall Hazard

Falls can result in severe personal injury or death.

Make sure that suitable equipment for performing tasks at height are used in accordance with local guidelines and legislation.

⚠ WARNING

Hot Pressurized Liquid

Contact with hot liquid can cause severe burns.

Do not open the pressure cap while the engine is running. Let the engine cool down before removing the cap. Turn the cap slowly and do not open it fully until the pressure has been relieved.

⚠ CAUTION

Hazardous Liquid

Prolonged or repeated skin contact can cause severe personal injury.

Avoid prolonged or repeated skin contact. Comply with all local health and safety regulations/codes during handling or disposal.

NOTICE

Do not add cold coolant to a hot engine. Damage to the engine can occur. Allow the engine to cool to below 50 °C (122 °F) before adding coolant.

NOTICE

Never use a sealing additive to stop leaks in the coolant system. This can result in a blocked coolant system and inadequate coolant flow causing the engine to overheat.

NOTICE

On applications that use a coolant recovery system, check to make sure the coolant is at the appropriate level on the coolant recovery tank dependent on engine temperature. Fill the cooling system with coolant to the bottom of the fill neck in the radiator or expansion tank, with the coolant temperature at 50 °C (122 °F) or lower.

NOTICE

Some radiators have two fill necks, both of which must be filled. Refer to the generator set specific drawings supplied with the generator set.

Coolant level must be checked daily.

Top up the cooling system with premixed fully formulated coolant or with a 50/50 mixture of high-quality water distilled or deionized and fully formulated concentrated antifreeze. The fully formulated coolant/antifreeze, either ethylene glycol or propylene glycol, must meet Cummins Engineering Standard 14603. Cummins Inc. recommends using Fleetguard® coolants containing DCA4. If the radiators are not filled using Fleetguard "Compleat" brand antifreeze or equivalent antifreeze, the DCA4 needs to be added to the cooling systems. If water quality is unknown, it can be tested with the Fleetguard® Monitor C™ program or Water-Chek™ test strip.

7.4.2.1 Coolant Level - Check

Top up the cooling system with premixed fully formulated coolant or with a 50/50 mixture of high-quality water distilled or deionized and fully formulated concentrated antifreeze. The fully formulated coolant/antifreeze, either ethylene glycol or propylene glycol, must meet Cummins Engineering Standard 14603. Cummins Inc. recommends using Fleetguard® coolants containing DCA4. If the radiators are not filled using Fleetguard "Compleat" brand antifreeze or equivalent antifreeze, the DCA4 needs to be added to the cooling systems.

If water quality is unknown, it can be tested with the Fleetguard® Monitor C™ program or Water-Chek™ test strip.

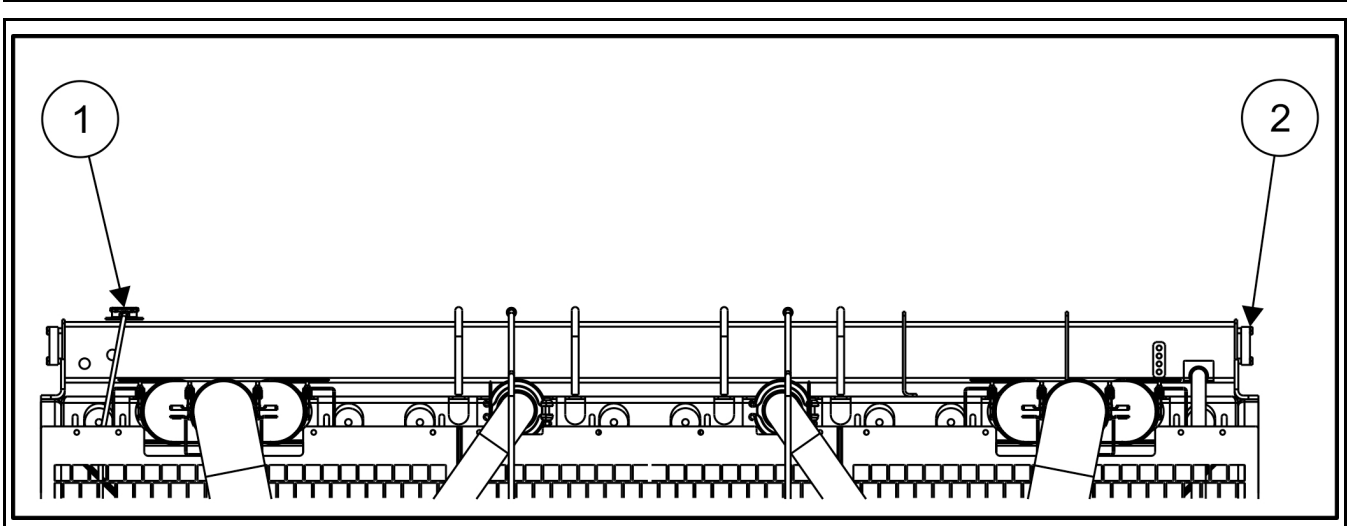

FIGURE 52. HEADER TANK

1. Observe the coolant level through the sight glass (2) at the top of the expansion tank. Coolant level should be approximately at the fill level in the sight glass.
2. Isolate the generator set to prevent accidental starting while filling the radiator.
3. Slowly remove the radiator filler cap (1).

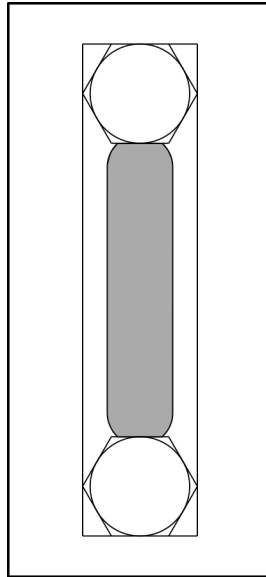

FIGURE 53. SIGHT GLASS

4. Begin slowly filling the radiator with a 50/50 mixture of fully formulated coolant and DCA4 (or equivalent) until the sight glass shows the correct level.
5. Replace the radiator cap securely. Push down and twist clockwise until the cap lip hits the tank stop flange.
6. Start the generator set and check for leaks.

7.4.3 Drive Belt - Inspection

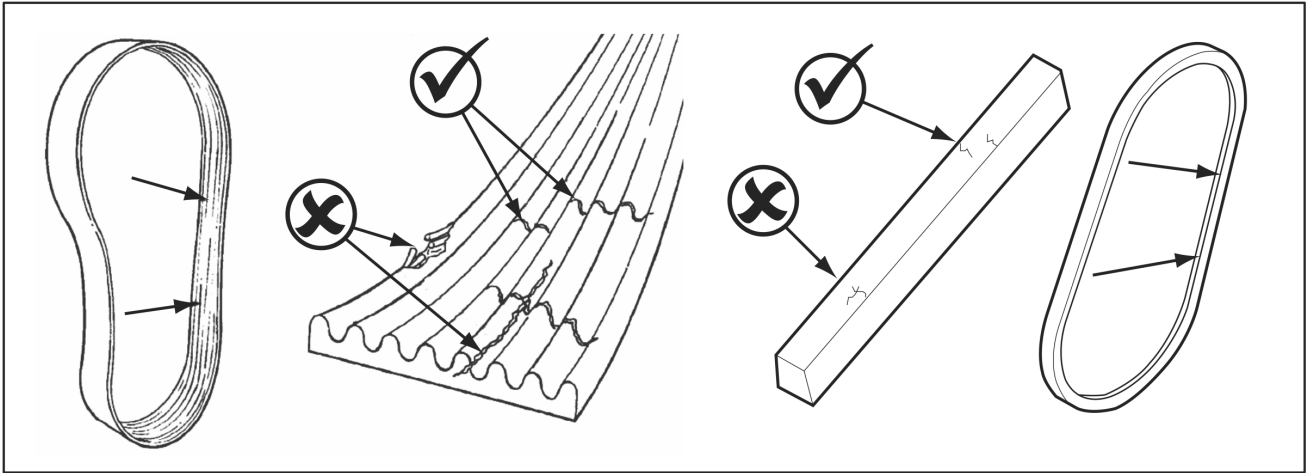

FIGURE 54. DRIVE BELT INSPECTION

Visually inspect the belt through the guarding.

Check for:

- Intersecting cracks. Small transverse (across the belt width) cracks are acceptable. Longitudinal (direction of belt length) cracks that intersect with transverse cracks are not acceptable.
- Frays or pieces of material missing.
- Glazed or cracked side walls.
- Uneven wear on sidewalls of belt.

NOTICE

Do not mix old and new V-belts on the same drive.

Contact your authorized distributor to have worn belts replaced.

Visually inspect sheaves through the guarding.

Check for:

- Damaged or worn grooves.
- Breaks on flanges of grooves.
- Frays or pieces of material missing.
- Glazed or cracked side walls.
- Uneven wear on sidewalls of belt.

NOTICE

V-Belts should never ride in the bottom of the groove. Damaged or worn grooves should not be used.

NOTICE

Keep foreign materials away from sheaves and belts as this may cause belt slip.

Contact your authorized distributor to have worn sheaves replaced.

7.4.4 Radiator Check

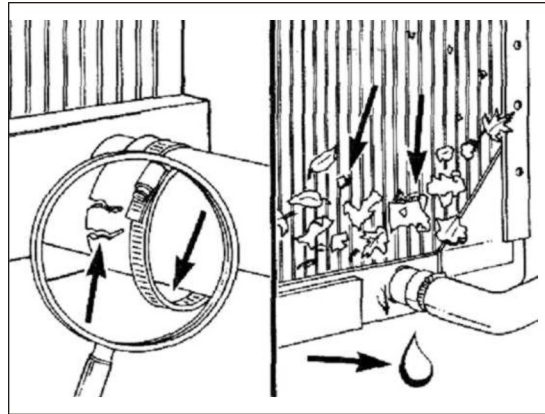

FIGURE 55. RADIATOR CHECK

Check for damaged hoses and loose and damaged hose clamps.

Inspect the exterior of the radiator (through the guarding) for obstructions. During the service life of a radiator a buildup of foreign matter can obstruct the flow of air through the radiator cores, reducing the cooling capability. To continue the efficiency of the radiator, the core will require cleaning.

Cleaning of the radiator core must only be undertaken by suitably trained and experienced service personnel.

7.4.5 Cooling Fan - Inspection

⚠ WARNING

Moving Parts

Moving parts can cause severe personal injury.

Use extreme caution around moving parts. All guards must be properly fastened to prevent unintended contact.

NOTICE

Never pull or pry on the fan. This can damage the fan blade(s) and cause fan failure.

A visual inspection of the cooling fan is required daily. Check for loose rivets or retaining bolts, for cracks, and bent or loose blades .

Do not operate the generator set with a damaged fan. Contact your authorized distributor for repair or replacement of a damaged fan.

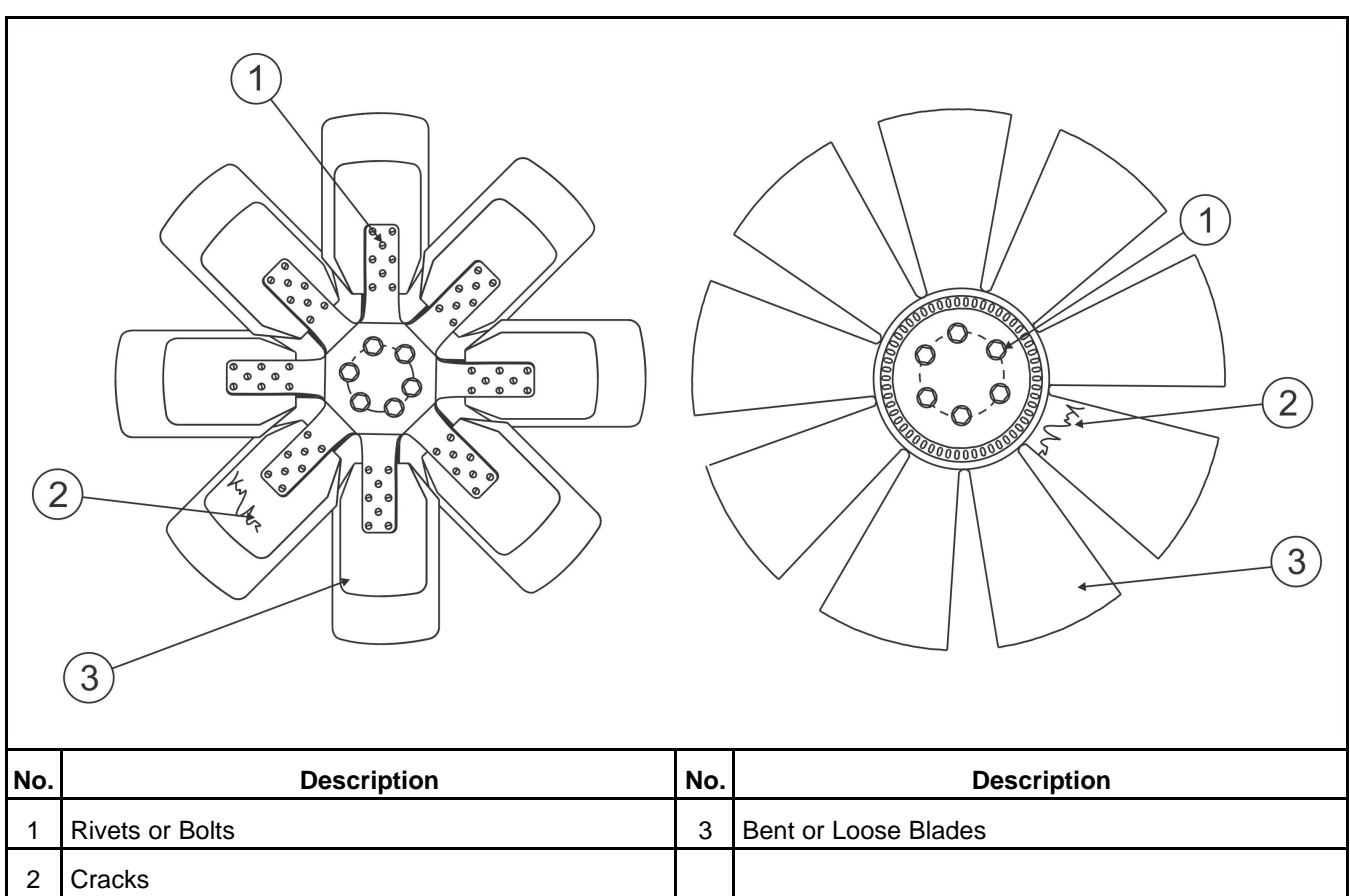

FIGURE 56. COOLING FAN INSPECTION CHECKPOINTS

7.5 Engine Oil

7.5.1 Level Check

⚠ WARNING

Hot Pressurized Liquid
 Contact with hot liquid can cause severe burns.
 Crankcase pressure can blow out hot oil. Do not check the oil while the generator set is operating.

⚠ CAUTION

Hazardous Liquid
 Prolonged or repeated skin contact can cause severe personal injury.
 Avoid prolonged or repeated skin contact. Comply with all local health and safety regulations/codes during handling or disposal.

NOTICE

Do not operate the engine with the oil level below the low mark or above the high mark. Overfilling can cause foaming or aeration of the oil while operation below the low mark may cause loss of oil pressure.

NOTICE

Use high-quality multi-viscosity lubricating oil such as Cummins Premium Blue® or its equivalent. Consult your authorized distributor for the correct lubricating oil specifications for your operating conditions.

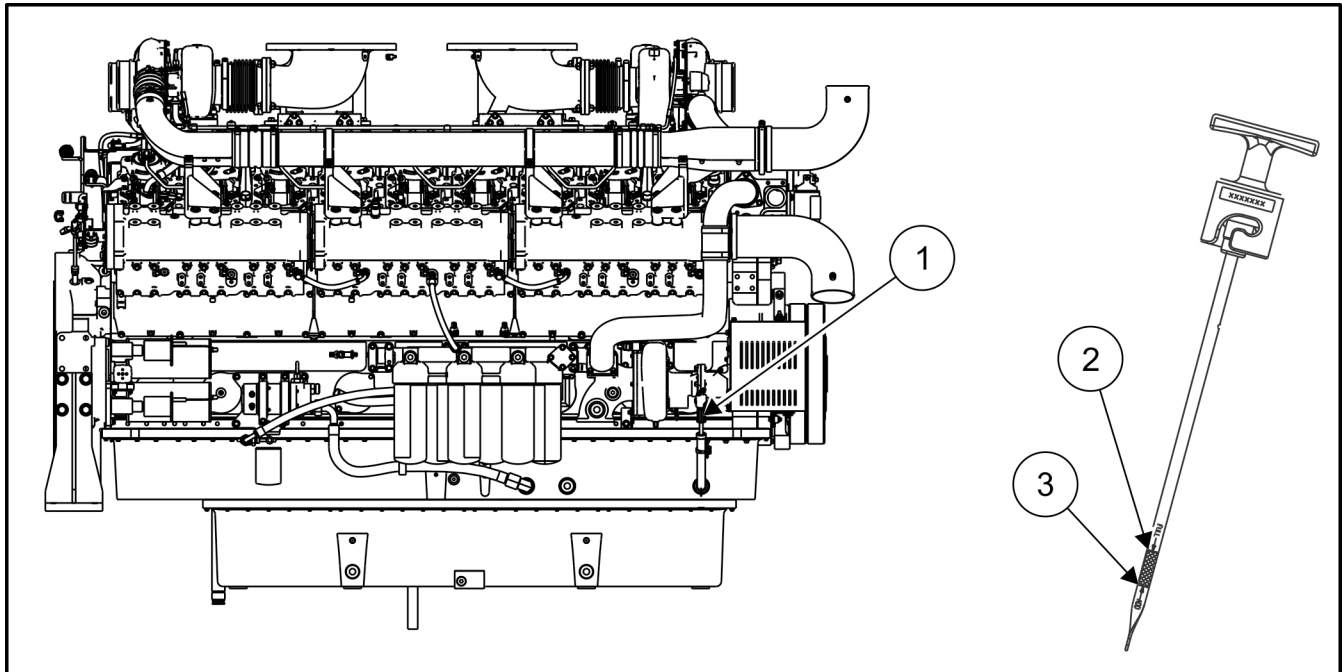

FIGURE 57. OIL LEVEL CHECK

The engine oil level must be checked daily before starting the engine, when the generator set is not running.

Never operate the engine with the oil level below the L (Low) mark (3), or above the H (High) mark (2).

1. Remove the dipstick (1) and with a lint free cloth wipe the dipstick clean.
2. Fully replace the dipstick.
3. Remove the dipstick and check the level of oil against the High and Low marks on the dipstick.
4. Top up to the High mark (2) if necessary with the correct grade of oil for your application.
 - a. Remove the filler cap.
 - b. Place a lint free cloth beneath or around the oil filler neck to minimize spillage.
 - c. Where possible use a funnel to help pour the new engine oil into the oil filler neck to the correct level.
 - d. Using the dipstick check the oil level, do not overfill the system. If more oil is needed then continue to fill with oil until the correct level is reached. If the level is too high then some of the oil will need to be drained of, refer to the engine operator and maintenance manual.
 - e. Replace the dipstick and oil filler cap.

- f. Remove the lint free cloth, start the engine and allow to idle for five minutes, switch the engine off wait five minutes to allow the oil to drain back to the oil pan.
- g. Check the oil level. Repeat steps (1-5) if oil needs to be added.

Clean up any spillage and dispose of materials in accordance with local regulations.

7.5.2 Oil Fill

NOTICE

Before carrying out any maintenance, isolate all supplies to the generator set and any control panels. Render the set inoperative by disconnecting the battery.

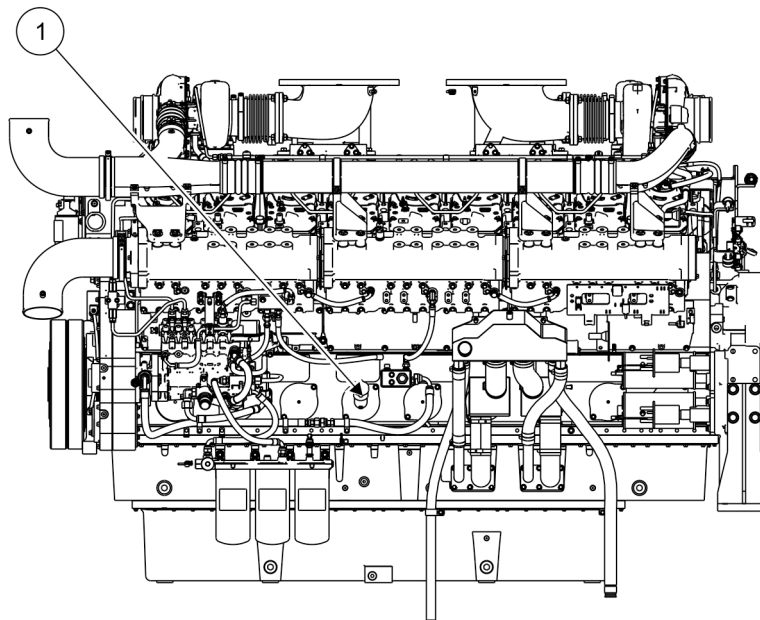

No.	Description
1	Oil Fill Cap

FIGURE 58. ENGINE OIL FILL LOCATION

1. Complete lock out procedure to ensure safe working environment.
2. Refer to the Engine Operation & Maintenance Manual for the correct grade of oil to be used. Or consult your authorized distributor for the correct lubricating oil for your operating conditions.
3. Fill the engine to the correct level with clean engine oil.
4. Check the oil level on the dipstick. The level must be on the high (H) mark on the dipstick. **Do Not Overfill.**

NOTICE

If the oil level is exceeded, drain off excess oil.

5. Return the generator set to the proper operating conditions.
6. Operate the generator set at idle speed and check for leaks.
7. Shut down the generator set.
8. Wait approximately 5 minutes to allow the oil to drain from the upper parts of the engine.
9. Rectify any leaks.
10. Check the oil level.
11. Add oil as necessary to bring the oil level to the high (H) mark on the dipstick.
12. Dispose of waste material in accordance with local regulations.

7.5.3 Oil Sampling

It is important to conduct oil analysis on new (unused) oil to establish a baseline. New (unused) oil analysis samples should be taken twice a year or each time the oil type is changed at a minimum. Samples should be taken from the bulk supply tanks to determine the makeup of the oil and also to confirm that no contaminants are being introduced by the storage system.

The sample to be used for analysis must be representative of the oil in the engine. Use the following guidelines when collecting oil samples:

- Bring the engine to operating temperature prior to sampling. This will make sure representative contaminant levels are in the sampled increment.
- Successive samples must be taken in the same manner and from the same location.
- Take the oil sample before adding any new oil to the engine.
- Always collect the oil in a clean, dry container.
- Fill the sample bottle as directed by the instructions supplied with the oil sampling kit/laboratory

Further details are available on Cummins Service Bulletin (3810340) for Cummins Engine Oil and Oil Analysis Recommendations.

7.5.3.1 Oil Sampling Valve

WARNING

Moving Parts

Moving parts can cause severe personal injury.

Use extreme caution around moving parts. All guards must be properly fastened to prevent unintended contact.

WARNING

Toxic Hazard

Used engine oils have been identified by some state and federal agencies to cause cancer or reproductive toxicity.

Do not ingest, breathe the fumes, or contact used oil when checking or changing engine oil. Wear protective gloves and face guard.

⚠ WARNING**Hot Oil**

Contact with hot oil can cause severe burns.

Avoid direct contact with hot oil. Allow the engine to cool down before carrying out any maintenance.

NOTICE

The oil sampling intervals are dependent on usage, location and customers own requirements.

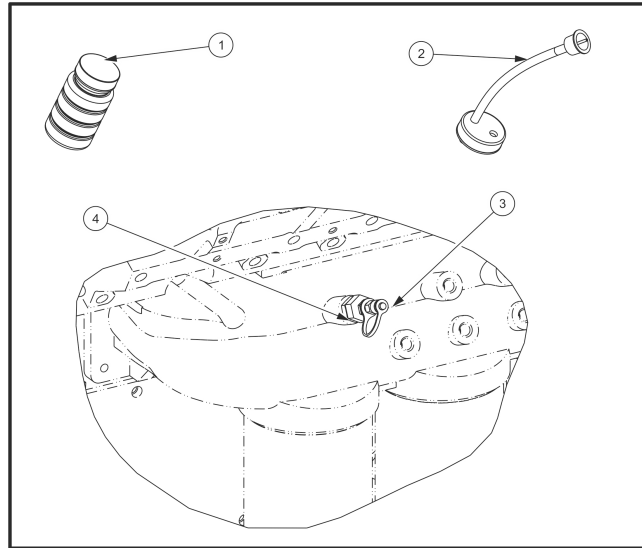

FIGURE 59. TYPICAL OIL SAMPLING VALVE

1. Remove the cap from the sample bottle (1) and attach the live sampling cap (2).
2. Remove the oil sampling drain valve cap (3) from the valve (4).
3. With the engine running at normal operating temperature, screw the live sampling cap (2) onto the drain valve (4), to allow the needle to fully depress the ball valve.
4. Fill the sample bottle as directed by the instructions supplied with the oil sampling kit/laboratory.
5. Remove the sample bottle (1) and replace the valve cap (3).
6. Remove the live sampling cap (2) from the sample bottle (1).
7. Replace the oil sampling bottle cap (1) and send for analysing.
8. Clean up any spillage and dispose of contaminated materials in accordance with local regulations.

7.6 Fuel System

⚠ WARNING**Combustible Liquid**

Diesel fuel is a fire and explosion hazard which can cause severe personal injury or death.

Do not permit any open flame, or other igniter near the fuel system, or in areas sharing ventilation.

⚠ WARNING***Combustible Liquid***

Mixing gasoline or alcohol with diesel fuel is an explosion hazard which can result in severe personal injury or death.

Do not mix gasoline or alcohol with diesel fuels.

NOTICE

Engine fuel actuators can operate at voltages up to 140 volts DC.

NOTICE

Due to the precise tolerances of diesel injection systems, it is extremely important that the fuel be kept clean and free of dirt or water. Dirt or water in the system can cause severe damage to both the injection pump and the injection nozzles.

Use ASTM No. 2D fuel with a minimum Cetane number of 40. No. 2 diesel fuel gives the best economy and performance under most operating conditions. Fuels with Cetane numbers higher than 40 are often needed in high altitudes, or extremely low ambient temperatures, to prevent misfires and excessive smoke. Contact your authorized distributor for your operating conditions.

NOTICE

A diesel fuel to BS 2869:2010+A1:2011 (Fuel oils for agricultural, domestic, and industrial engine and boilers. Specification), conforming to the requirements and test methods of that specification would be an acceptable alternative to ASTM No. 2D.

7.6.1 Fuel Level

To avoid condensation problems, keep fuel supply tanks as full as possible by filling up each time the engine is used. Condensation (water) can cause clogging of the fuel filters as well as possible freezing problems. In addition, water mixing with the sulfur in the fuel forms acid which can corrode and damage engine parts.

NOTICE

When refueling, make sure that the fuel level does not exceed the maximum limit. If the fuel level exceeds the limit, it can cause leakage and can obstruct the fuel cap breather.

NOTICE

When filling the generator set fuel tank, make sure the fuel filler cap breather is not blocked. If the fuel cap breather is blocked it can cause air intake into the fuel tank to be erratic. Make sure the fuel filler cap is cleaned after each fill.

7.6.2 Fuel/Water Separator - Spin on Type

A set-mounted integral fuel/water separator is fitted to provide protection for the engine fuel injection system as water-free fuel supplies cannot be guaranteed.

Drain the water and sediment from the separator daily.

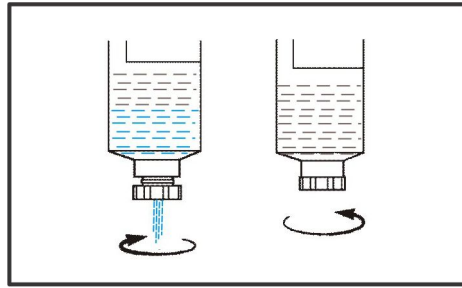

FIGURE 60. DRAINING THE FUEL/WATER-SEPARATOR

1. Shut off the engine.
2. Wait 1 minute to remove any pressure in the fuel line.
3. Place a suitable container under the fuel filter.

NOTICE

If more than 60 ml (2 oz) is drained, refilling of the filter is required to prevent hard starting.

4. Turn the valve clockwise, four complete turns, until the valve drops down one inch. Drain the filter sump of water until clear fuel is visible.

NOTICE

Do not over tighten the valve. Over tightening can damage the threads.

5. When clear fuel begins to flow out of the drain, push the valve up and turn the valve counterclockwise to close drain valve.
6. Before starting the engine, be sure to remove the container and clean up any fuel spillage.
7. Start the engine and check for any leaks.

NOTICE

The drained liquids must be disposed of in accordance with local environmental regulations.

7.7 Fuel Filter Maintenance

7.7.1 Fuel Filters - Drain

Refer to the engine specific manual for a more detailed procedure for draining the fuel filters.

Drain the water and sediment daily. The fuel filters can be inspected for collected water by checking the clear bowl at the bottom of each filter.

To drain the water:

1. Shut off the engine.
2. Place a suitable container under the fuel filter.
3. With the fuel supply valve closed, open the vent cap to break the airlock in the filter.
4. Open the drain valve. Accumulated water will drain first.

5. When fuel begins to flow out of the drain, close the drain valve.

The drained liquids must be disposed of in accordance with local environmental regulations.

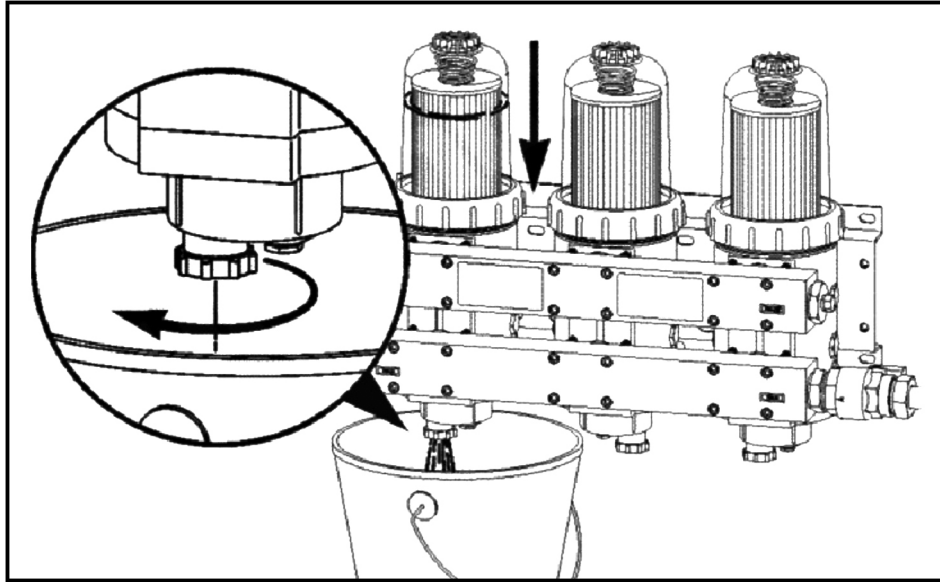

FIGURE 61. DRAINING THE FILTER/SEPARATORS

7.7.2 Fuel Filters - Element Removal

WARNING

Combustible Liquid

Diesel fuel is a fire and explosion hazard which can cause severe personal injury or death. Do not permit any open flame, or other igniter near the fuel system, or in areas sharing ventilation.

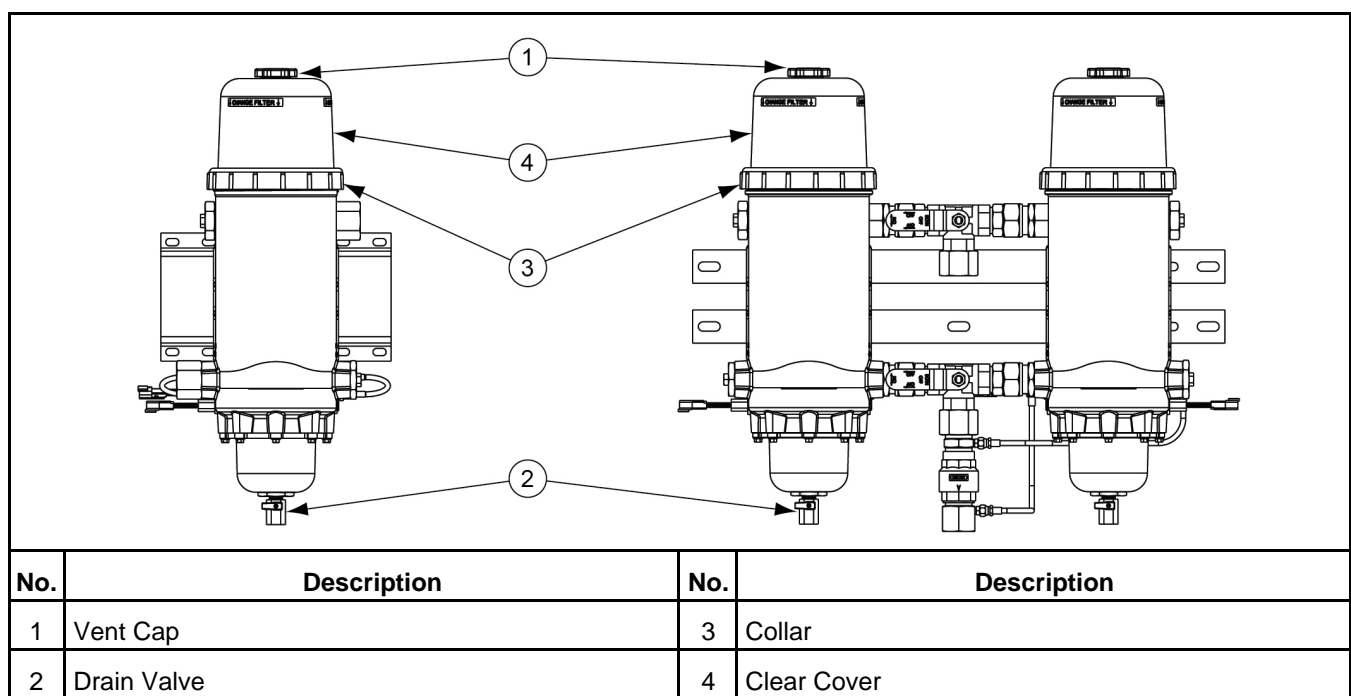

FIGURE 62. FUEL FILTER REMOVAL - SINGLE TALL AND DUPLEX FUEL FILTERS

NOTICE

The fuel must be drained from the filter head prior to removing the element. Do not allow fuel to drain onto the ground. Drained fuel must be collected and disposed of in accordance with local environmental regulations.

1. Shut down the engine.
2. Close the fuel supply shutoff valve.
3. Place a suitable container under the filter to be replaced.
4. Use the collar/vent cap wrench to open the vent cap to break the air lock in the filter.
5. Open the drain valve, and allow the fuel level to drain to a point below the collar.
6. Close the drain valve.
7. Loosen the collar with the collar/vent cap wrench.
8. Remove the clear cover, filter spring, fuel filter element, and o-ring.
9. Remove the sealing grommet.
10. Discard the o-ring and grommet.

7.7.3 Fuel Filters - Element Removal

WARNING

Combustible Liquid

Diesel fuel is a fire and explosion hazard which can cause severe personal injury or death. Do not permit any open flame, or other igniter near the fuel system, or in areas sharing ventilation.

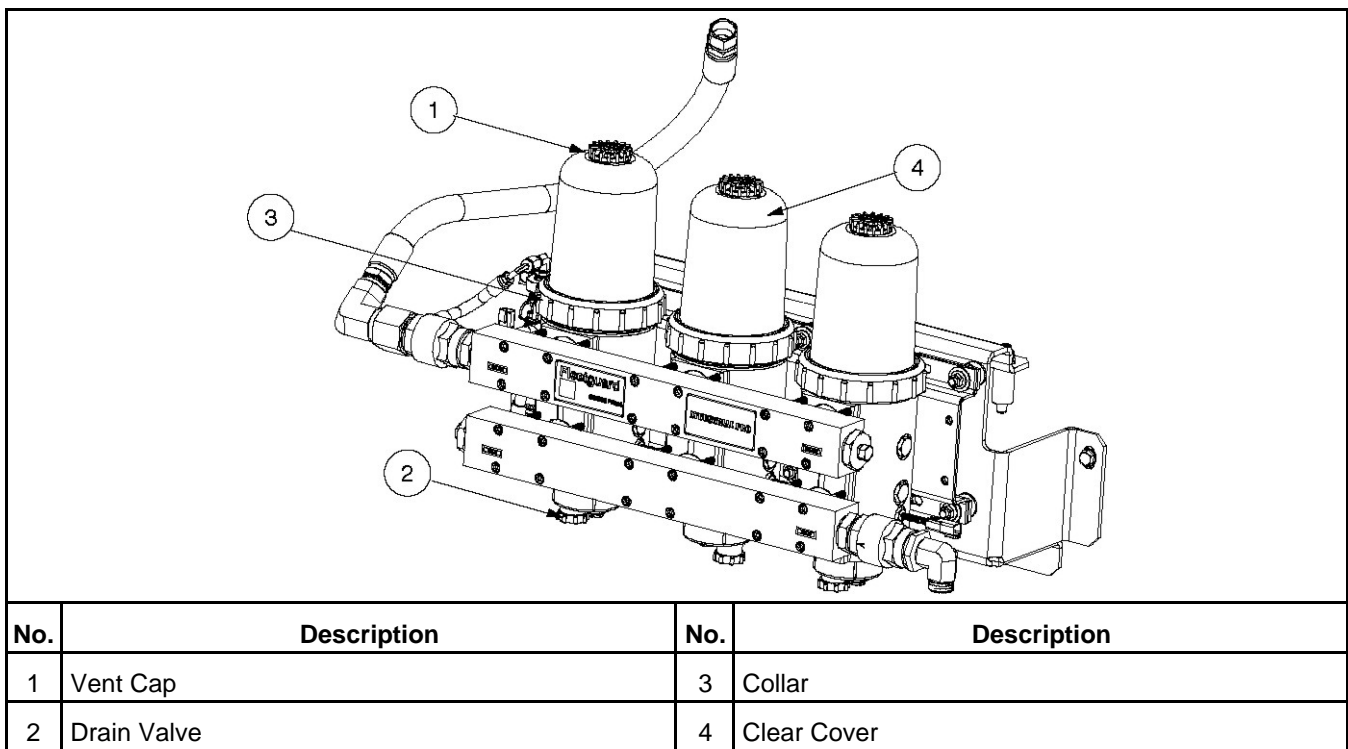

FIGURE 63. FUEL FILTER REMOVAL

NOTICE

The fuel must be drained from the filter head prior to removing the element. Do not allow fuel to drain onto the ground. Drained fuel must be collected and disposed of in accordance with local environmental regulations.

1. Shut down the engine.
2. Close the fuel supply shutoff valve.
3. Place a suitable container under the filter to be replaced.
4. Use the collar/vent cap wrench to open the vent cap to break the air lock in the filter.
5. Open the drain valve, and allow the fuel level to drain to a point below the collar.
6. Close the drain valve.
7. Loosen the collar with the collar/vent cap wrench.
8. Remove the clear cover, filter spring, fuel filter element, and o-ring.
9. Remove the sealing grommet.
10. Discard the o-ring and grommet.

7.7.4 Fuel Filter - Element Replacement

⚠ WARNING

Combustible Liquid

Diesel fuel is a fire and explosion hazard which can cause severe personal injury or death. Do not permit any open flame, or other igniter near the fuel system, or in areas sharing ventilation.

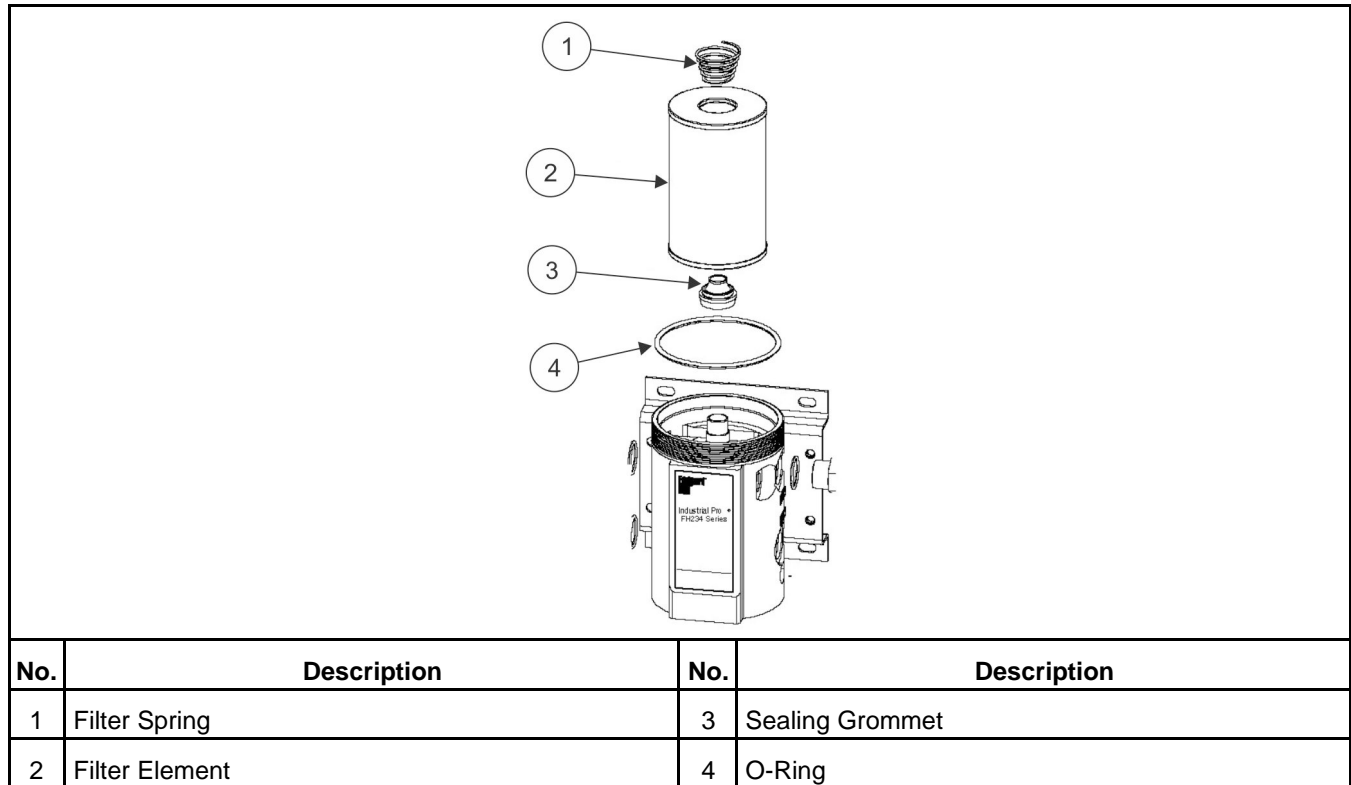

FIGURE 64. FUEL FILTER ELEMENT

NOTICE

Fuel filter replacement includes the appropriate o-ring and sealing grommet. The o-ring and grommet must be replaced with the filter element to make sure of proper operation.

1. Install a new o-ring, filter element (supplied with a sealing grommet inserted into the filter element), filter spring, and clear cover.
2. Install the vent cap and the collar onto the clear cover.
3. Hand tighten. Do not use tools to tighten the collar.

7.8 Fluid Containment

The bedframe fluid containment area (if applicable) must be inspected at regular intervals and any liquid should be drained off and disposed of in accordance with local health and safety regulations. Failure to perform this action may result in spillage of liquids likely to contaminate the surrounding area.

Any other fluid containment area must also be checked and emptied, as above.

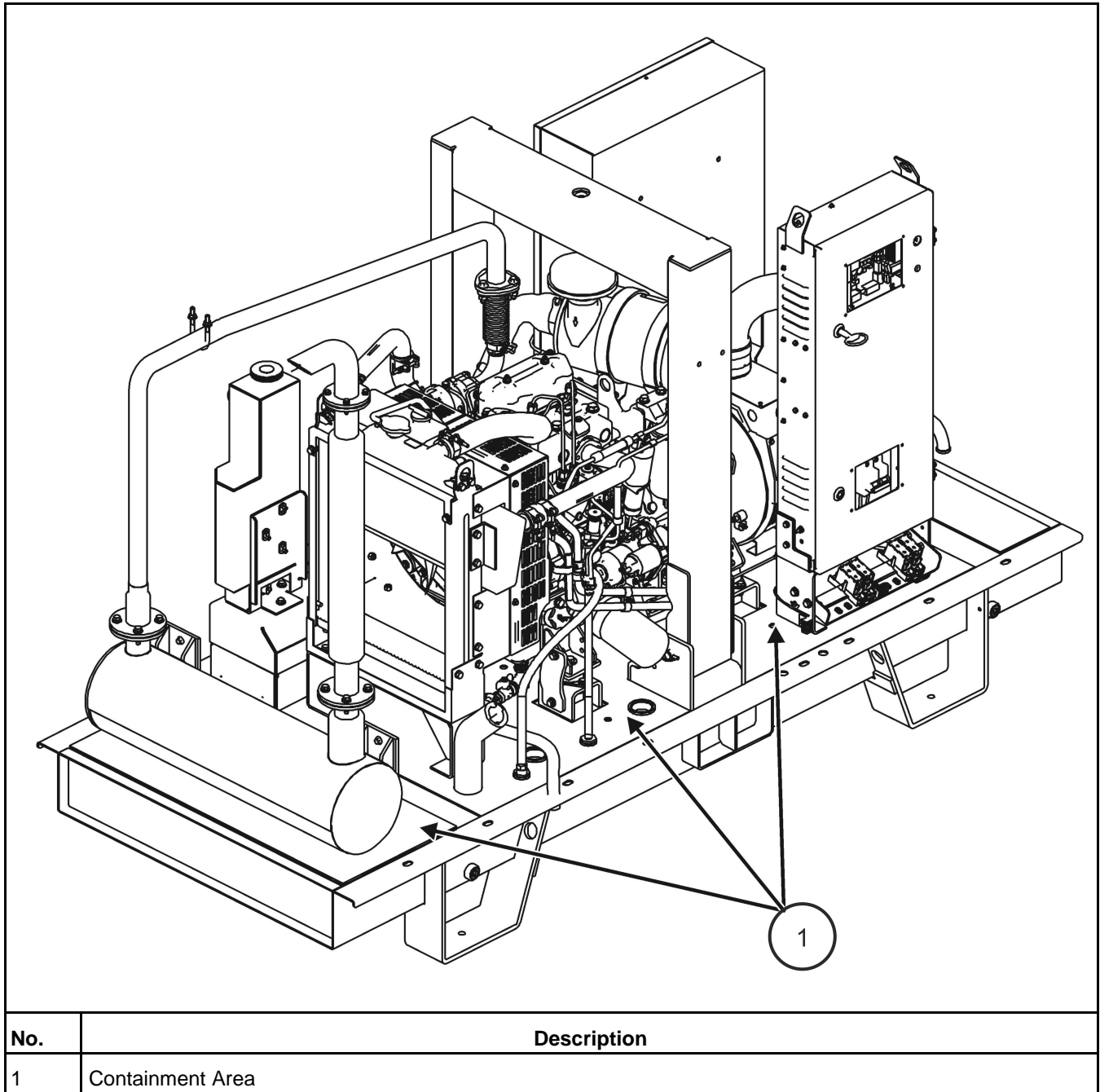

FIGURE 65. TYPICAL FLUID CONTAINMENT AREA (ENCLOSURE REMOVED FOR CLARITY)

NOTICE

Generator set shown is not representative of all models.

7.9 Hoses and Fuel Lines - Check

⚠ WARNING

Moving Parts

Moving parts can cause severe personal injury.

Use extreme caution around moving parts. All guards must be properly fastened to prevent unintended contact.

⚠ WARNING

Hot Surfaces

Contact with the hot surfaces can cause severe burns.

Avoid contact with hot parts. Allow hot parts to completely cool.

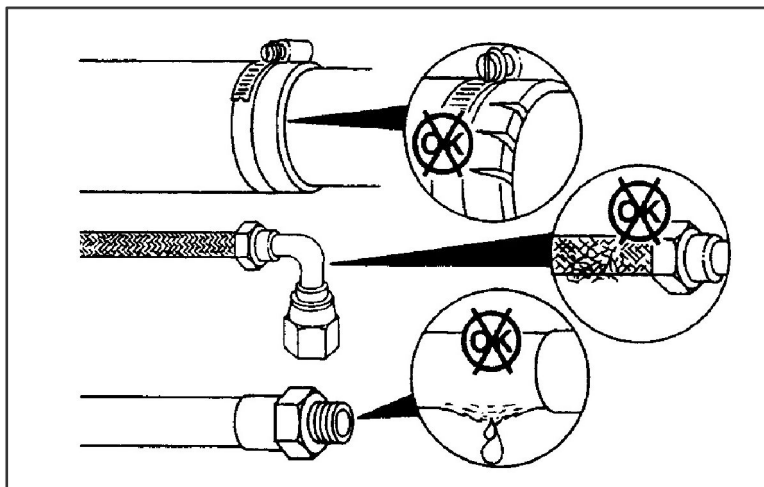

FIGURE 66. HOSES AND FUEL LINE INSPECTION

While the generator set is in operation, visually inspect the fuel lines, filters, and fittings for leaks. Check any flexible sections for cuts, cracks and abrasions and make sure they are not rubbing against anything that could cause breakage. If any leaks are detected, shut down the generator set (if possible). Contact your authorized distributor and have the leaks repaired immediately.

7.10 Air Intake System

The direct flow air cleaner consists of a primary filter and a secondary filter within the air cleaner housing. The air cleaner has been designed for a maximum restriction, at which point the filter elements should be changed. Refer to the Model Specifications section.

7.10.1 Air Cleaner Service Indicator

⚠ WARNING

Moving Parts

Moving parts can cause severe personal injury.

Use extreme caution around moving parts. All guards must be properly fastened to prevent unintended contact.

⚠ WARNING
<p>Hot Surfaces Contact with the hot surfaces can cause severe burns. Avoid contact with hot parts. Allow hot parts to completely cool.</p>

The air cleaner service indicator is located either on the air cleaner assembly or between the assembly and the inlet side of the turbocharger.

Check the air cleaner service indicator. If the gauge has crossed the red mark (1), replace the filter.

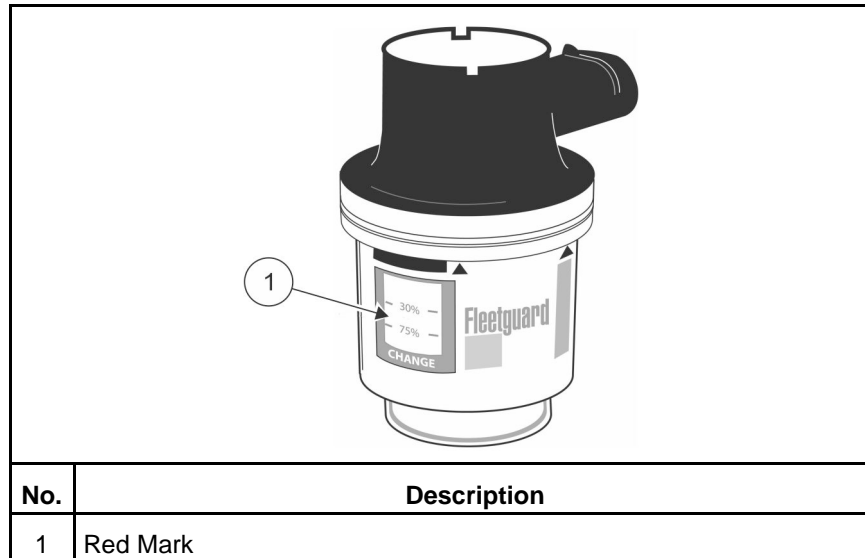

FIGURE 67. AIR CLEANER SERVICE INDICATOR

7.10.2 Normal Duty Air Cleaner

7.10.2.1 Air Filter Element Removal

NOTICE
<p>Holes, loose-end seals, dented sealing surfaces, corrosion of pipes, and other forms of damage render the air cleaner inoperative and require immediate element replacement or engine damage can occur.</p>

NOTICE
<p>Cummins Inc. does not recommend cleaning paper-type air cleaner elements. Elements that have been cleaned will clog, and airflow to the engine will be restricted.</p>

Use care when servicing components for the engine combustion air intake system.

- Loosen air filter straps (1) and band clamp (2).
- Slide the air filter element (3) straight toward the front of the engine to remove.
- Repeat steps 1-3 to remove the remaining three filter elements.

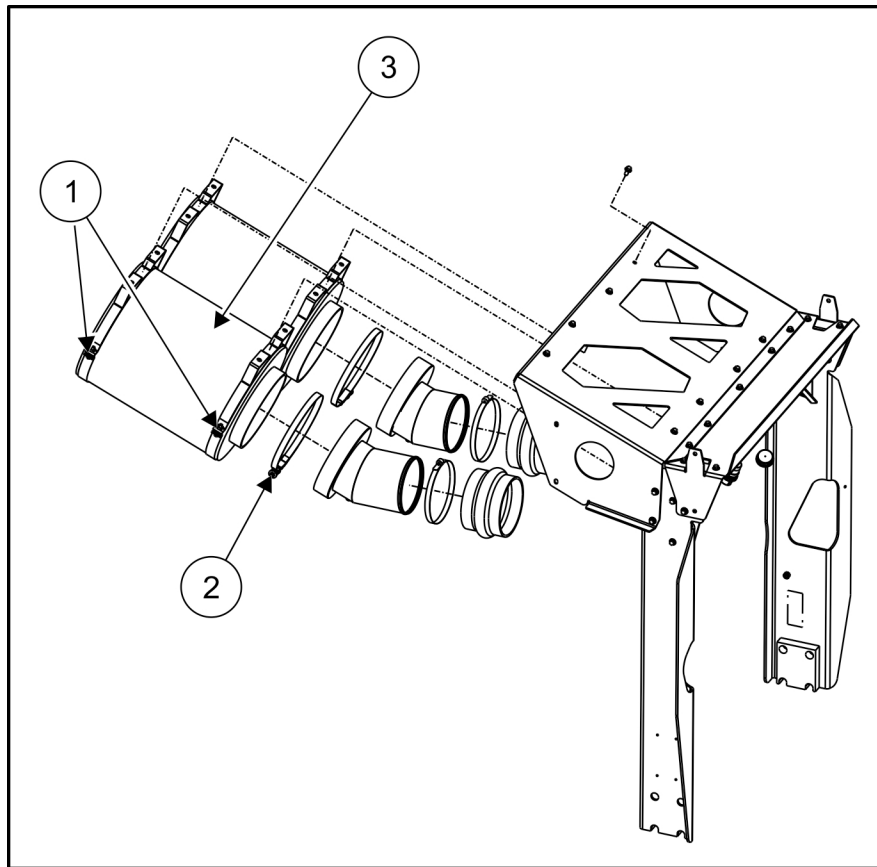

FIGURE 68. NORMAL DUTY AIR CLEANER

7.10.2.2 Air Filter Element Installation

1. Install the new air filter element (3) by sliding toward the rear of the engine within the air filter straps (1).

NOTICE

Air filter straps must be aligned with the black rubber air filter element ends. Failure to properly align the air filter element could result in damage to the air filter element.

2. Tighten the band clamp to secure the air filter element to the air induction pipe (2). Torque to 11 nm (97 in-lb).
3. Tighten the two air filter straps to secure the air filter element (1). Torque to 4.5 nm (40 in-lb).
4. Repeat steps 1-3 to remove the remaining three air filter elements.

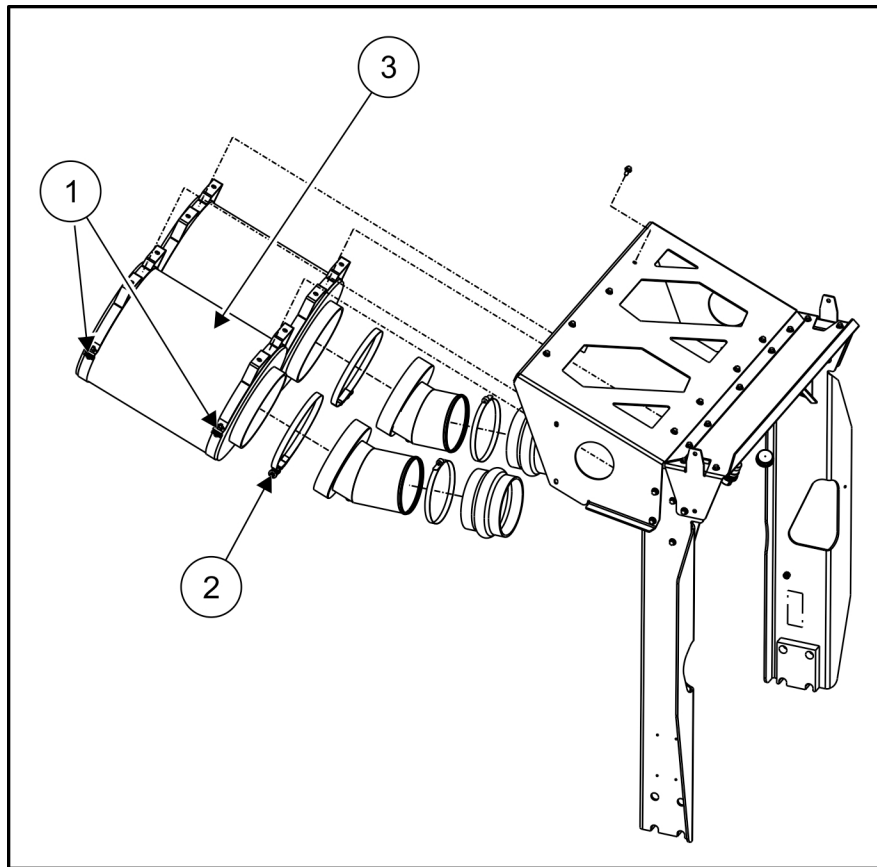

FIGURE 69. NORMAL DUTY AIR CLEANER

7.11 Exhaust System

⚠ WARNING

Hot Surfaces

Contact with the hot surfaces can cause severe burns.
 Avoid contact with hot parts. Allow hot parts to completely cool.

⚠ WARNING

Moving Parts

Moving parts can cause severe personal injury.
 Use extreme caution around moving parts. All guards must be properly fastened to prevent unintended contact.

⚠ WARNING

Toxic Gases

Substances in exhaust gases have been identified by some state and federal agencies to cause cancer or reproductive toxicity.
 Do not breathe in or come into contact with exhaust gases.

While the generator set is in operation, inspect the entire exhaust system visually and audibly including the exhaust manifold, muffler, and exhaust pipe without removing guarding and panels. Check for leaks at all connections, welds, gaskets and joints, and make sure that exhaust pipes are not heating surrounding areas excessively. If any leaks are detected, shut down the generator set (if possible). Contact your authorized distributor and have the leaks repaired immediately.

7.12 Generator Set Output - AC Electric System

Check the following while the generator set is operating:

- Frequency: The generator set frequency should be stable and the reading should be the same as the generator set nameplate rating (50 Hz / 1500 RPM or 60 Hz / 1800 RPM).
- AC Voltage: At no load, the line-to-line voltage, or voltages, should be the same as the generator set nameplate rating.
- AC Ammeter: At no load, the current readings should be zero. With a load applied, each line current should be similar.
- Panel Lamps: When the Operating Panel is first connected to the DC supply, the system runs a check, illuminating each of the indicator lamps in turn.

7.13 DC Electrical System

⚠ WARNING

Combustible Gases

Ignition of battery gases is a fire and explosion hazard which can cause severe personal injury or death.

Do not smoke, or switch the trouble light ON or OFF near a battery. Touch a grounded metal surface first before touching batteries to discharge static electricity. Stop the generator set and disconnect the battery charger before disconnecting battery cables. Using an insulated wrench, disconnect the negative (-) cable first and reconnect it last.

1. Check the harness connections. If any harness connections are damaged, contact your service representative.

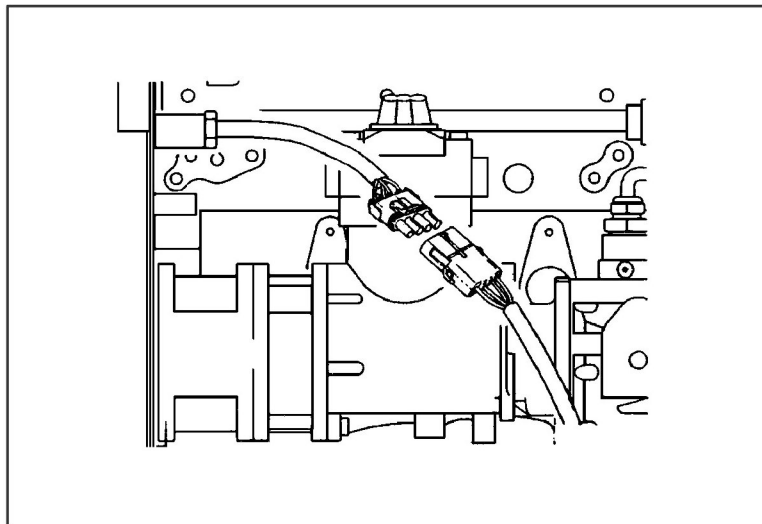

FIGURE 70. CHECK HARNESS CONNECTIONS

2. Check the terminals on the batteries for clean and tight connections. Loose or corroded connections create resistance, which can hinder starting. Clean and reconnect the battery cables if loose, using an insulated wrench. Always disconnect both ends of the negative battery cable. Reconnect one end of the cable to the negative battery terminal and the other end to ground. This will make sure that any arcing will be away from the battery and least likely to ignite explosive battery gases.
3. Check connections at the battery charging alternator.
4. Visually inspect the alternator belt to make sure it is not loose or cracked.

7.14 Batteries

Batteries are an essential part of any standby generator system. Roughly 90% of all generator failures are due to batteries.

It is important that batteries are stored, commissioned, and maintained as detailed here. Refer also to the *Battery Manufacturer's Instructions*.

Always use correct handling techniques when moving or lifting batteries. Batteries can be heavy and may require more than one person to lift and a suitable trolley for transportation.

Batteries are usually supplied with the generator in 'dry-charged' form. In order to commission dry-charged lead-acid batteries, pre-mixed electrolyte of the correct type and specific gravity must be added to the cells of the battery. Refer to the *Manufacturer's Service Literature*.

Maintenance free batteries supplied with the generator need no maintenance for commissioning.

7.14.1 Storage

Batteries must be stored in a cool, dry, well-ventilated place, in the upright position, and with the vent caps securely in place.

Batteries must never be stacked on top of each other and must be protected from the floor by a wooden pallet or suitably thick cardboard sheet.

7.14.2 Battery Type Specification

TABLE 27. BATTERY SPECIFICATION

Electrical System	
Starting Voltage	24 Volts DC
Battery Group Number	8D
CCA (minimum) Cold Soak at -18 °C (0 °F)	1400
Required Battery Quantity	6

7.14.3 Safety Precautions

Servicing of batteries are to be performed or supervised by personnel knowledgeable of batteries and the required precautions. Keep unauthorized personnel away from batteries.

7.14.3.1 General Precautions

WARNING

Combustible Gases

Ignition of battery gases is a fire and explosion hazard which can cause severe personal injury or death.

Laying tools or metal objects across the battery can cause arcing. Never lay tools or metal objects across the top of the battery.

- Use proper PPE. Do not wear jewelry. Remove any conductive items from pockets. These items can fall into equipment and result in a short circuit, which can cause shock or burning. Refer to local standards for PPE details.
- Use tools with insulated handles to prevent the risk of electric shock.

7.14.3.2 Fire Hazard

NOTICE

During the charging of a battery, explosive gases are given off. Keep the battery area well ventilated and away from naked flames and sparks. Do not smoke.

- Before disconnecting a battery, isolate the utility powered battery charger (where fitted).
- To disconnect the battery, use an insulated wrench to disconnect the negative cable first.
- To connect the battery, use an insulated wrench to connect the negative cable last.

7.14.3.3 Fluid Hazard

WARNING

Toxic Hazard

Contact with electrolyte can cause severe personal injury.

Wear appropriate PPE when handling electrolyte: acid-proof protective apron, goggles, rubber gloves and boots. If electrolyte is splashed on the skin or in the eyes, flush the affected areas immediately with water and seek medical attention.

WARNING

Hazardous Liquid

Uncontrolled chemical reactions can cause severe chemical burns or death.

Never add undiluted sulfuric acid to a battery.

7.14.4 Battery Maintenance

WARNING

Combustible Gases

Ignition of battery gases is a fire and explosion hazard which can cause severe personal injury or death.

Do not smoke, or switch the trouble light ON or OFF near a battery. Touch a grounded metal surface first before touching batteries to discharge static electricity. Stop the generator set and disconnect the battery charger before disconnecting battery cables. Using an insulated wrench, disconnect the negative (-) cable first and reconnect it last.

NOTICE

To prevent dangerous arcing, always disconnect the negative (-) ground cable from the battery using an insulated wrench before working on any parts of the electrical system or the engine. Before touching batteries, discharge static electricity from body by first touching a grounded metal surface.

NOTICE

Always disconnect a battery charger from its AC source before disconnecting the battery leads. Failure to do so can result in voltage spikes high enough to damage the DC control circuits of the generator set.

NOTICE

Maintenance-free batteries are sealed and do not require the addition of electrolyte. Some manufacturers of maintenance-free batteries provide an 'eye' or some visible means of telling when the battery is discharged or approaching the end of its useful life.

NOTICE

In generator sets equipped with an electronic Engine Control Module (ECM), press the emergency stop button and wait 90 seconds prior to disconnecting the battery. By not performing this step the ECM may experience a data save process interruption and set Fault Code 1117 (SPN/FMI 3597/2).

Batteries require attention at all times, even when not working. A battery will not last if it is neglected. Maintenance is carried out as follows:

1. Keep the battery and the battery area clean and dry. If fitted, make sure that the vent caps are securely screwed down, or pushed home.
2. To avoid contamination of the battery, clean it only when the vent plugs (if fitted) are in place.
3. Keep the battery terminals and connections free from corrosion by lightly coating them with petroleum jelly.
4. Secure the battery(s) to prevent movement and internal damage to plates.
5. Check the condition of the starting batteries.

7.14.4.1 Cleaning Batteries

⚠ WARNING

Toxic Hazard

Contact with electrolyte can cause severe personal injury.

Wear appropriate PPE when handling electrolyte: acid-proof protective apron, goggles, rubber gloves and boots. If electrolyte is splashed on the skin or in the eyes, flush the affected areas immediately with water and seek medical attention.

⚠ CAUTION

A deformed battery may lead to explosion which can result in burn hazard.

Prevent a buildup of dirt or corrosion by wiping the batteries with a damp cloth. Use a solution consisting of 0.11 kg (1/4 lb) of baking soda added to 0.96 liters (1 quart) of water to neutralize any possible acid. Be sure the vent plugs (if fitted) are tight to prevent any cleaning solution from entering the cells.

After cleaning, make sure the battery and surrounding areas are dry.

After making connections, coat the terminals with a light application of petroleum jelly to retard corrosion. Keep the battery terminals clean and tight. A loose connection can reduce battery standby time and cause battery fires.

7.14.4.2 Charging

When generator sets are used infrequently, batteries must be re-charged monthly to maintain a fully-charged condition.

NOTICE

Never allow a battery to become completely flat (fully discharged), or to stand in a discharged condition, or damage will result.

⚠ CAUTION

Battery cable should be connected in proper sequence. Positive Terminal should be connected first to avoid any spark or Burn Hazard.

1. Do not put a battery into storage without first giving the battery a commissioning charge.
2. Batteries must be given a further charge every 3 months at the normal initial charge rate until the voltage ceases to rise. Refer to the manufacturer's service literature.

The expected battery recharge time depends on the existing battery charge. The battery charge is directly proportional to its voltage. The following table shows the typical battery charging percentage based on the voltage.

TABLE 28. BATTERY CHARGE AND VOLTAGE

Battery Voltage with no Load Connected (Volts)	Battery Charging (%)
> 12.60	100%
12.40 – 12.59	80% to 99%
12.10 – 12.39	60% to 79%

Battery Voltage with no Load Connected (Volts)	Battery Charging (%)
12.00 – 12.09	40% to 59%
11.70 – 11.99	30% to 40%
< 11.70	< 30%

The charging time also depends on the state of health of the battery and the current supplied by the charger. Batteries must not be recharged with a current that is greater than 10% of the battery rated load capacity. The following table shows the typical battery charging time when it is charged to 10% of its nominal charge capacity.

TABLE 29. TYPICAL CHARGING TIME

Battery Charging (%)	Typical Recharging Time (hours)
> 60%	> 4.5
40% to 59%	> 7
30% to 39%	> 9
< 30%	> 11

7.14.4.3 Trickle/Boost Charging (Option)

The battery automatically receives a trickle-charge from the battery charger (when switched ON) to prevent the battery from becoming discharged below its optimum charge level.

⚠ CAUTION
<i>Possible Short circuit or thermal burn hazard due to hanging battery charger near alternator or Flywheel Housing.</i>

During trickle-charging, not all cells in the battery receive the same charge. Over a period of several months, this may affect battery performance. It is therefore good practice to give batteries a regular charge at their full rate to return all cells to full capacity. This is referred to as boost-charging, or equalize-charging.

If the charger is fitted with a **Boost Charge** switch, the **Boost** position should be selected at intervals detailed by the battery manufacturer (normally around every six months).

NOTICE
Batteries should not be left on Boost Charge for extended periods as this may impair battery performance.

A boost charge not exceeding twice the bench charge rate may be used, providing that the battery volts do not reach 15 V (for a 12 V battery). If this happens, reduce the charge rate to the normal bench rate. For tropical climates the temperature must not exceed 49 °C (120 °F).

NOTICE

The charge period should be extended:

- To 8 hours if the battery has been in storage for three months or more at temperatures in excess of 30 °C (86 °F), or if humidity is above 80%.
- To 12 hours if the battery has been in storage for twelve months or more.

7.14.5 Battery Fault Finding

The following table shows some typical faults and their possible causes and remedies.

TABLE 30. FAULT FINDING

Symptom	Possible Fault	Remedy
Battery completely discharged	Poor battery terminal connection	Clean connections, replace and tighten.
	Charge alternator/ alternator connection fault	Contact your nearest Cummins distributor.
	Mains battery charger/ charger connections fault/ mains supply fault	Contact your nearest Cummins distributor.
	Blown fuse	Contact your nearest Cummins distributor.
	Battery fault	Contact your nearest Cummins distributor.
Battery low charge	Poor battery connection	Clean connections, reconnect and tighten securely.
	Charge alternator/ alternator connection fault	Contact your nearest Cummins distributor.
	Mains battery charger/ charger connections fault	Contact your nearest Cummins distributor.
	Inequality in cell charge	Contact your nearest Cummins distributor.
	Battery fault	Contact your nearest Cummins distributor.
Battery overcharged	Charge alternator fault	Contact your nearest Cummins distributor.
	Mains battery charge fault	Contact your nearest Cummins distributor.
Battery terminals getting hot	Poor battery connection	Clean connections, reconnect and tighten securely.
		Contact your nearest Cummins distributor.

8 Troubleshooting

Fault code information, together with warning and shutdown information, is provided in this section to assist in locating and identifying the possible causes of faults in the generator set system.

Refer also to the Operator's engine specific manual. The engine manual contains additional information regarding the running and care of the generator set as well as specific equipment instructions that may differ from the standard generator set.

8.1 Control System

The generator set control system continuously monitors engine sensors for abnormal conditions, such as low oil pressure and high coolant temperature. If any of these conditions occur, the control will light a yellow Warning lamp or a red Shutdown lamp and will display a message on the graphical display panel. In the event of an engine shutdown fault (red Shutdown LED), the control will stop the engine immediately.

8.2 Safety Considerations

WARNING

Hazardous Voltage

Contact with high voltages can cause severe electrical shock, burns, or death.

Make sure that only personnel who are trained and qualified to work on this equipment are allowed to operate the generator set and perform maintenance on it.

WARNING

Automated Machinery

Accidental or remote starting of the generator set can cause severe personal injury or death.

Make sure that the generator set cannot be started accidentally or remotely before starting work on the generator.

WARNING

Combustible Gases

Ignition of battery gases is a fire and explosion hazard which can cause severe personal injury or death.

Do not smoke, or switch the trouble light ON or OFF near a battery. Touch a grounded metal surface first before touching batteries to discharge static electricity. Stop the generator set and disconnect the battery charger before disconnecting battery cables. Using an insulated wrench, disconnect the negative (-) cable first and reconnect it last.

CAUTION

Hazardous Voltage

Contact with high voltages can cause severe electrical shock, burns, or death.

Isolate all external electrical supplies prior to access of the control panel. Internal components have live exposed terminations even when the generator set is not running.

NOTICE

Isolator switch only: Do not open the output box while the generator set is running as the isolator switch will cause the generator set to shut down. Keep the output box covers in place during troubleshooting.

NOTICE

Always disconnect a battery charger from its AC source before disconnecting the battery cables. Failure to do so can result in voltage spikes high enough to damage the DC control circuits of the generator set.

NOTICE

Ventilate the battery area before working on or near the battery. Wear goggles. Stop the generator set and disconnect the battery charger before disconnecting the battery cables using an insulated wrench. Disconnect the negative (-) cable first and reconnect it last.

All maintenance tasks must be assessed for health and safety risks; the preventive measures identified must be performed. An additional person is required for any task where doing so significantly adds to the safety of the task.

The installation of a generator set can be designed for remote starting. When troubleshooting a generator set that is shut down, make sure that the generator set cannot be accidentally restarted. Refer to the *Locking the Generator Set Out of Service* section.

8.3 Fault Finding

⚠ WARNING***Electrical Generating Equipment***

Incorrect operation and maintenance can result in severe personal injury or death.

Make sure that only suitably trained and experienced service personnel perform electrical and/or mechanical service.

⚠ WARNING***Risk of Fire***

Using incorrect/inappropriate parts can affect generator set operation which may result in severe personal injury or death.

Replace fuses only with same type and ratings of fuse.

NOTICE

Review safety precautions listed within [Chapter 1](#) of this manual together with the documentation supplied with the generator set.

Should a fault condition occur during operation, follow the procedures in the following tables to locate and correct the problem. For any symptom not listed, contact your authorized distributor for assistance.

Before starting any fault finding, ensure that the following basic checks are carried out:

- All switches and controls are in their correct positions.
- Fuel system is connected and fuel is available.

- The lubricating oil level is correct.
- The coolant level is correct.
- The radiator matrix is free from obstruction.
- The battery charge condition is satisfactory and the connections are secure.
- The generator set electrics and alternator connections are secure.
- The panel connections are secure.
- The protection circuits have been reset.
- Blown fuses have been replaced.
- Tripped contacts or circuit breakers have been reset.
- Battery isolator is to the ON position (if fitted).

8.4 Status Indicators - PowerCommand 3.3

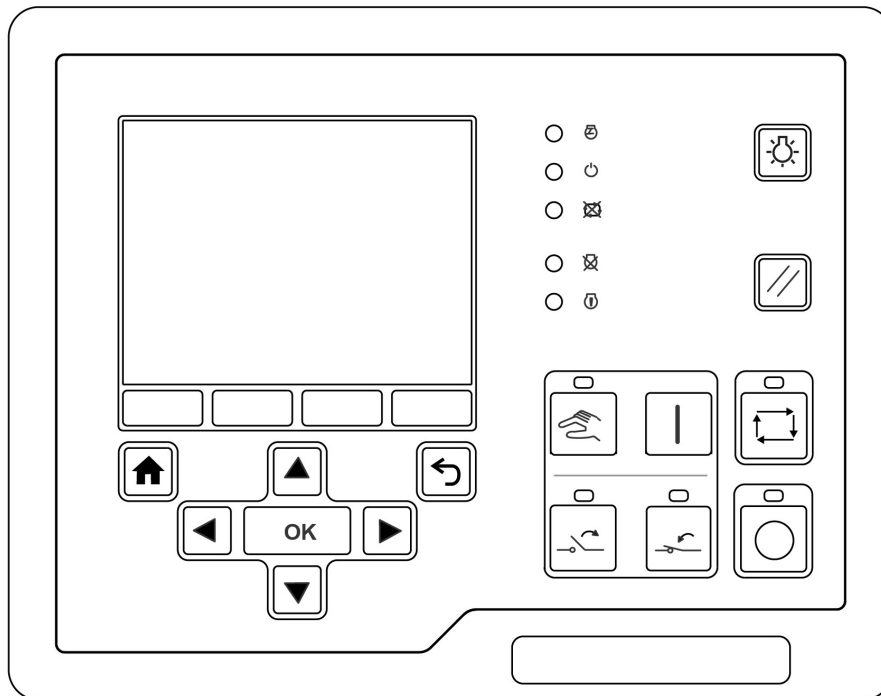

FIGURE 71. OPERATOR PANEL (HMI 320)

8.4.1 Not in Auto

This red lamp is lit when the control is not in Auto.

8.4.2 Remote Start

This green lamp indicates the control is receiving a Remote Run signal. The Remote Run signal has no effect unless the generator set is in Auto.

8.4.3 Warning

This amber lamp is lit whenever the control detects a Warning condition. This lamp is automatically shut off when the Warning condition no longer exists.

8.4.4 Shutdown Status

This red lamp is lit when the control detects a Shutdown condition. The generator set cannot be started when this lamp is on. After the condition has been corrected, the lamp can be reset by first pressing the **Stop** button and then the **Reset** button.

8.4.5 Generator Set Running Lamp

The green lamp is lit when the generator set is running at, or near, rated speed and voltage. This is not lit while the generator set is warming up or cooling down.

8.5 Fault/Status Codes - PowerCommand 3.3

WARNING

Troubleshooting procedures.

Troubleshooting procedures present hazards that can result in severe personal injury or death.

Only trained and experienced service personnel with knowledge of fuels, electricity, and machinery hazards should perform service procedures.

WARNING

Accidental starting.

Accidental starting of the generator set while working on it can cause severe personal injury or death.

Prevent accidental starting by disconnecting the starting battery leads (negative [-] first).

NOTICE

Gaps in the code numbers are for codes that do not apply to this generator set. Some of the codes listed are feature dependent and will not be displayed by this control.

8.5.1 Fault Messages

A Fault message is an indicator of a Warning or Shutdown condition. It includes the fault type (Warning or Shutdown), fault number, and a short description. It also includes where the fault occurred if the generator set control did not detect the fault and is simply reporting the fault.

Active and acknowledged faults may be viewed in the Faults menu.

8.5.2 Fault Acknowledgement

Shutdown faults must be acknowledged after the fault has been corrected. If in Auto or Manual mode, the control must be set to Stop mode (Off). Faults are cleared from the control panel display by pressing the **Reset** button.

Faults are also acknowledged when in Auto mode and the remote start command is removed.

Faults are re-announced if they are detected again after being acknowledged.

8.5.3 Fault Codes - PowerCommand 3.3

TABLE 31. FAULT CODES

Code	Lamp	Displayed Message
111	Shutdown	Internal ECM Failure
115	Shutdown	Eng Crank Sensor Error
121	Warning	Engine Magnetic Crankshaft Speed or Position Lost One of Two Signals
122	Warning	Manifold 1 Press High
123	Warning	Manifold 1 Press Low
124	Warning	Manifold 1 Press High
135	Warning	High Oil Rifle 1 Pressure
137	Warning	Oil Inlet Pressure Low Error
141	Warning	Low Oil Rifle 1 Pressure
142	Warning	Oil Overpressure
143	Warning	Low Oil Rifle Pressure
144	Warning	High Coolant 1 Temp
145	Warning	Low Coolant 1 Temp
146	Derate	Pre-High Engine Coolant Temperature
151	Shutdown	High Coolant Temp
153	Warning	High Intake Manf 1 Temp
154	Warning	Low Intake Manf 1 Temp
155	Shutdown	High Intake Manf 1 Temp
156	Warning	Intake Manifold Temp 2 OOR High
157	Warning	Intake Manifold Temp 2 OOR Low
158	Shutdown	Intake Manifold Temp 2 High
159	Warning	Intake Manifold Temp 3 OOR High
161	Warning	Intake Manifold Temp 3 OOR Low
162	Shutdown	Intake Manifold Temp 3 High
163	Warning	Intake Manifold Temp 4 OOR High
164	Warning	Intake Manifold Temp 4 OOR Low
165	Shutdown	Intake Manifold Temp 4 High
175	Shutdown	Throttle Control OOR High
176	Shutdown	Throttle Control OOR Low
177	Shutdown	Throttle Control Out of Adjustment

Code	Lamp	Displayed Message
187	Warning	Sensor Supply 2 Low
189	Shutdown	HT Coolant Temperature Cause Unknown
195	Warning	High Coolant 1 Level
196	Warning	Low Coolant 1 Level
197	Warning	Low Coolant Level
212	Warning	High Oil 1 Temperature
213	Warning	Low Oil 1 Temperature
214	Shutdown	High Oil 1 Temp
219	Warning	Eng Oil Level Remote Reservoir: Least Severe Level
221	Warning	Air Pressure Sensor High
222	Warning	Air Pressure Sensor Low
223	Warning	Oil Burn Valve Sol Low
224	Warning	Oil Burn Valve Sol High
227	Warning	Sensor Supply 2 Low
228	Shutdown	Low Coolant Pressure
229	Warning	HT Coolant Pressure Incorrect
231	Warning	High Coolant Pressure
232	Warning	Low Coolant Pressure
233	Warning	HT Coolant Pressure Moderate Low
234	Shutdown	Crankshaft Speed High
235	Shutdown	Low Coolant Level
236	Shutdown	Both Engine Speed Signals Lost
238	Warning	Sensor Supply 3 Low
239	Warning	Main Supply High
244	Warning	Red Stop Lamp Driver OOR Low
245	Warning	Fan Control Low
246	Warning	Exhaust Gas Temp Sensor 1 OOR High
247	Warning	Exhaust Gas Temp Sensor 1 OOR Low
248	Shutdown	Exhaust Gas Temp Sensor 1 High
253	Shutdown	Oil Level Low
254	Shutdown	FSO PWM High Control Error
255	Warning	FSO PWM Low Control Error
259	Warning	Engine Fuel Shutoff Valve Stuck Open
261	Warning	High Fuel Temperature

Code	Lamp	Displayed Message
263	Warning	High Fuel 1 Temperature
265	Warning	Low Fuel 1 Temperature
266	Shutdown	High Fuel Temperature
271	Warning	Low Fuel Pump Press
272	Warning	High Fuel Pump Press
277	Warning	Fuel Control Valve Out of Adjustment
281	Warning	Cylinder Press Imbalance
284	Warning	Eng Speed/Position Sensor: Voltage Below Normal
285	Warning	CAN Mux PGN Rate Error
286	Warning	CAN Mux Calibration Error
287	Warning	CAN Mux Accel Data Error
295	Warning	Key On Air Pressure Error
311	Warning	ACT1 FF Shorted HS TO LS Error
312	Warning	ACT5 Shorted HS TO LS Error
313	Warning	ACT3 RF Shorted HS TO LS Error
314	Warning	ACT6 Shorted HS TO LS Error
315	Warning	ACT2 FT Shorted HS TO LS_Error
319	Warning	RTC PWR Intr: Data Erratic Intermittent or Wrong
321	Warning	ACT4 RT Shorted HS TO LS Error
322	Warning	Inj 1 Solenoid Low Curr
323	Warning	Inj 5 Solenoid Low Curr
324	Warning	Inj 3 Solenoid Low Curr
325	Warning	Inj 6 Solenoid Low Curr
331	Warning	Inj 2 Solenoid Low Curr
332	Warning	Inj 4 Solenoid Low Curr
334	Warning	HT Coolant Temperature Incorrect
341	Warning	Engine Control Module Data Lost
342	Shutdown	Calibration Code Fail
343	Warning	ECM Hardware Failure
346	Warning	Powerdown Data Lost
351	Warning	Injector Supply Failure
352	Warning	Sensor Supply 1 Low
354	Warning	Manifold Absolute Pressure 1 High
355	Warning	Manifold Absolute Pressure 1 Low

Code	Lamp	Displayed Message
359	Shutdown	Fail to Start
378	Warning	Elect Fuel Inj Cntrl Valve Ckt: Curr Below Normal
379	Warning	Elect Fuel Inj Cntrl Valve Ckt: Curr Above Normal
386	Warning	Sensor Supply 1 High
394	Warning	Eng Timing Actuator Driver: Curr Below Normal
395	Warning	Eng Timing Actuator Driver: Curr Above Normal
396	Warning	Fuel Cntl Valve Solenoid Driver 2 Sensor Ckt: OC
397	Warning	Fuel Cntl Valve Solenoid Driver 2 -
398	Warning	Eng Timing Actuator Driver 2 Circuit: OC
399	Warning	Eng Timing Actuator Driver 2: Grounded Ckt
412	Event	J1708 Link Cannot Transmit
414	Event	J1708 Link Not Fast Enough
415	Shutdown	Low Oil Rifle Press
418	Warning	High H2O in Fuel
419	Warning	Intake Manifold Pres Bank Imbalance: Data Erratic
421	Warning	High Oil Temperature
422	Warning	Coolant Level Data Error
425	Warning	Oil Temperature Error
426	Event	SAE J1939 Datalink - Data Erratic, Intermittent, or Incorrect
427	Warning	CAN Data Link Degraded
428	Warning	Water In Fuel Indicator Sensor: Volt Above Normal
429	Warning	Water In Fuel Indicator Sensor: Volt Below Normal
433	Warning	Intake Manifold Press Sensor Ckt: Data Erratic
435	Warning	Oil Pressure Switch Error
441	Warning	Low Battery 1 Voltage
442	Warning	High Battery 1 Voltage
449	Shutdown	Inj Metering 1 Press High
451	Warning	Inj Metering 1 Press High
452	Warning	Inj Metering 1 Press Low
453	Warning	Gas Mass Flow High
454	Warning	Gas Mass Flow Low
458	Shutdown	Spark Timing B Error
459	Shutdown	Spark Timing A Error
461	Shutdown	Spark Reference B Error

Code	Lamp	Displayed Message
462	Shutdown	Spark Reference A Error
471	Warning	Sump Oil Level Warning
477	Warning	Isolated Battery Voltage Low
478	Warning	Isolated Battery Voltage High
479	Warning	Exhaust Gas Temperature Data Incorrect
482	Warning	Fuel Press Low: Valid But Below Normal: Mod Severe
483	Warning	IMR 2 Pressure Sensor Circuit Shorted to High
484	Warning	IMR 2 Pressure Sensor Circuit Shorted to Low
488	Derate	High Intake Manf 1 Temp
496	Warning	Eng Speed Sensor 2 Supply Volt: Root Cause Unknown
512	Warning	Throttle Position 1 Feedback OOR High
513	Warning	Throttle Position 1 Feedback OOR Low
515	Warning	Sensor Supply 6 Circuit OORH
516	Warning	Sensor Supply 6 Circuit OORL
546	Warning	Fuel Delivery Press High
547	Warning	Fuel Delivery Press Low
553	Warning	APC Pressure High
554	Warning	APC Pressure Error
555	Warning	Crankcase Pressure High: Above Normal
556	Shutdown	Crankcase Pressure High
557	Shutdown	Fuel Control Valve 2 OOR High
558	Warning	Fuel Control Valve 2 OOR Low
559	Warning	Inj Metering 1 Press Low
561	Shutdown	Heavy Knock Error 1 (A1)
562	Shutdown	Heavy Knock Error 2 (B1)
563	Shutdown	Heavy Knock Error 3 (A2)
564	Shutdown	Heavy Knock Error 4 (B2)
565	Shutdown	Heavy Knock Error 5 (A3)
566	Shutdown	Heavy Knock Error 6 (B3)
567	Shutdown	Heavy Knock Error 7 (A4)
568	Shutdown	Heavy Knock Error 8 (B4)
569	Shutdown	Heavy Knock Error 9 (A5)
571	Warning	Knock Cylinder 1 (A1) OOR Low
572	Warning	Knock Cylinder 2 (B1) OOR Low

Code	Lamp	Displayed Message
573	Warning	Knock Cylinder 3 (A2) OOR Low
574	Warning	Knock Cylinder 4 (B2) OOR Low
575	Warning	Knock Cylinder 5 (A3) OOR Low
576	Warning	Knock Cylinder 6 (B3) OOR Low
577	Warning	Knock Cylinder 7 (A4) OOR Low
578	Warning	Knock Cylinder 8 (B4) OOR Low
579	Warning	Knock Cylinder 9 (A5) OOR Low
581	Warning	Fuel Pump Intake Pressure Sensor OOR Hi
582	Warning	Fuel Pump Intake Pressure Sensor OOR Lo
583	Warning	Low Fuel Pump Intake Pressure
584	Warning	High Side DRV3 High Control Error
585	Warning	High Side DRV3 Low Control Error
591	Warning	Exhaust Backpressure High
592	Warning	Exhaust Backpressure Low
595	Warning	Turbo 1 Overspeed Warning Erro
611	Warning	Engine Hot Shut Down
618	Warning	Turbo 1 Inlet Pressure High
619	Warning	Turbo 2 Inlet Pressure High
621	None	Exh Gas Temp Cyl 1 Deviation Low: Below Normal
622	None	Exh Gas Temp Cyl 3 Deviation Low: Below Normal
623	None	Exh Gas Temp Cyl 5 Deviation Low: Below Normal
624	None	Exh Gas Temp Cyl 7 Deviation Low: Below Normal
625	None	Exh Gas Temp Cyl 9 Deviation Low: Below Normal
626	None	Exh Gas Temp Cyl 11 Deviation Low: Below Normal
627	None	Exh Gas Temp Cyl 13 Deviation Low: Below Normal
628	None	Exh Gas Temp Cyl 15 Deviation Low: Below Normal
631	None	Exh Gas Temp Cyl 2 Deviation Low: Below Normal
632	None	Exh Gas Temp Cyl 4 Deviation Low: Below Normal
633	None	Exh Gas Temp Cyl 6 Deviation Low: Below Normal
634	None	Exh Gas Temp Cyl 8 Deviation Low: Below Normal
635	None	Exh Gas Temp Cyl 10 Deviation Low: Below Normal
636	None	Exh Gas Temp Cyl 12 Deviation Low: Below Normal
637	None	Exh Gas Temp Cyl 14 Deviation Low: Below Normal
638	None	Exh Gas Temp Cyl 16 Deviation Low: Below Normal

Code	Lamp	Displayed Message
641	Shutdown	Exhaust Temperature 1 (A1) High
642	Shutdown	Exhaust Temperature 3 (A2) High
643	Shutdown	Exhaust Temperature 5 (A3) High
644	Shutdown	Exhaust Temperature 7 (A4) High
645	Shutdown	Exhaust Temperature 9 (A5) High
646	Shutdown	Exhaust Temperature 11 (A6) High
647	Shutdown	Exhaust Temperature 13 (A7) High
648	Shutdown	Exhaust Temperature 15 (A8) High
649	None	Engine Oil Change Needed
651	Shutdown	Exhaust Temperature 17 (A9) High
652	Shutdown	Exhaust Temperature 2 (B1) High
653	Shutdown	Exhaust Temperature 4 (B2) High
654	Shutdown	Exhaust Temperature 6 (B3) High
655	Shutdown	Exhaust Temperature 8 (B4) High
656	Shutdown	Exhaust Temperature 10 (B5) High
657	Shutdown	Exhaust Temperature 12 (B6) High
658	Shutdown	Exhaust Temperature 14 (B7) High
671	Warning	Exhaust Gas Temperature Cylinder 1 (A1) OOR Low
672	Warning	Exhaust Gas Temperature Cylinder 3 (A2) OOR Low
673	Warning	Exhaust Gas Temperature Cylinder 5 (A3) OOR Low
674	Warning	Exhaust Gas Temperature Cylinder 7 (A4) OOR Low
675	Warning	Exhaust Gas Temperature Cylinder 9 (A5) OOR Low
676	Warning	Exhaust Gas Temperature Cylinder 11 (A6) OOR Low
677	Warning	Exhaust Gas Temperature Cylinder 13 (A7) OOR Low
678	Warning	Exhaust Gas Temperature Cylinder 15 (A8) OOR Low
683	Warning	Turbo 2 Speed Moderate High
684	Warning	Turbo 2 Speed Moderate Low
685	Warning	Turbo 2 Speed Incorrect
686	Warning	Turbo 1 Speed Incorrect
687	Warning	Turbo 1 Speed Low
689	Warning	Crankshaft Speed Error
691	Warning	Turbocharger 1 Comp Intake Temp:Volt Above Normal
692	Warning	Turbocharger 1 Comp Intake Temp:Volt Below Normal
697	Warning	ECM Temperature High

Code	Lamp	Displayed Message
698	Warning	ECM Temperature Low
721	Warning	Exhaust Gas Temperature 2 (B1) OOR Low
722	Warning	Exhaust Gas Temperature 4 (B2) OOR Low
723	Warning	Exhaust Gas Temperature 6 (B3) OOR Low
724	Warning	Exhaust Gas Temperature 8 (B4) OOR Low
725	Warning	Exhaust Gas Temperature 10 (B5) OOR Low
726	Warning	Exhaust Gas Temperature 12 (B6) OOR Low
727	Warning	Exhaust Gas Temperature 14 (B7) OOR Low
728	Warning	Exhaust Gas Temperature 16 (B8) OOR Low
731	Warning	Crankshaft Mech Misalign
736	Warning	Starter Air Pressure OOR Low
737	Warning	Starter Air Pressure OOR High
738	Warning	Starter Air Pressure Underpressure Error
741	Warning	Air Filter Restriction Pressure High Error
742	Warning	Air Filter Restriction Pressure Low Error
743	Warning	Turbocharger 1 Compressor Intake Pressure Error
751	Warning	Gas Mass Flow In Range Error
752	Warning	Exhaust Gas Oxygen In Range Error
755	Warning	Injector Metering Rail 1 Pressure System Error
757	Warning	All Persistent Data Lost Error
778	Warning	EPS Backup Lost Sync Error
781	Shutdown	CAN Data Link Failure
782	Warning	SAE J1939 Data Link 2 Engine Network No Data Received – Condition Exists
783	Shutdown	Intake Manf 1 Rate Error
831	Warning	Spark Plug 1 (A1) OOR Low
832	Warning	Spark Plug 2 (B1) OOR Low
833	Warning	Spark Plug 3 (A2) OOR Low
834	Warning	Spark Plug 4 (B2) OOR Low
835	Warning	Spark Plug 5 (A3) OOR Low
836	Warning	Spark Plug 6 (B3) OOR Low
837	Warning	Spark Plug 7 (A4) OOR Low
838	Warning	Spark Plug 8 (B4) OOR Low
839	Warning	Spark Plug 9 (A5) OOR Low
841	Warning	Spark Plug 10 (B5) OOR Low

Code	Lamp	Displayed Message
842	Warning	Spark Plug 11 (A6) OOR Low
843	Warning	Spark Plug 12 (B6) OOR Low
844	Warning	Spark Plug 13 (A7) OOR Low
845	Warning	Spark Plug 14 (B7) OOR Low
846	Warning	Spark Plug 15 (A8) OOR Low
847	Warning	Spark Plug 16 (B8) OOR Low
848	Warning	Spark Plug 17 (A9) OOR Low
849	Warning	Spark Plug 18 (B9) OOR Low
891	Warning	Spark Plug 1 (A1) Root Cause Unknown
893	Warning	Spark Plug 3 (A2) Root Cause Unknown
894	Warning	Spark Plug 4 (B2) Root Cause Unknown
895	Warning	Spark Plug 5 (A3) Root Cause Unknown
896	Warning	Spark Plug 6 (B3) Root Cause Unknown
897	Warning	Spark Plug 7 (A4) Root Cause Unknown
898	Warning	Spark Plug 8 (B4) Root Cause Unknown
899	Warning	Spark Plug 9 (A5) Root Cause Unknown
911	Warning	Spark Plug 10 (B5) Root Cause Unknown
912	Warning	Spark Plug 11 (A6) Root Cause Unknown
913	Warning	Spark Plug 12 (B6) Root Cause Unknown
914	Warning	Spark Plug 13 (A7) Root Cause Unknown
915	Warning	Spark Plug 14 (B7) Root Cause Unknown
916	Warning	Spark Plug 15 (A8) Root Cause Unknown
917	Warning	Spark Plug 16 (B8) Root Cause Unknown
918	Warning	Spark Plug 17 (A9) Root Cause Unknown
919	Warning	Spark Plug 18 (B9) Root Cause Unknown
982	Warning	Spark Plug 2 (B1) Root Cause Unknown
1117	Warning	Power Lost With Ignition On
1121	Warning	Fail To Disconnect
1122	Event	Rated To Idle Delay
1124	Warning	Delayed Shutdown
1128	Warning	Mixer Inlet Humidity Sensor:Volt Above Normal
1129	Warning	Mixer Inlet Humidity Sensor:Volt Below Normal
1131	Warning	Battle Short Active
1132	Warning	Controlled Shutdown

Code	Lamp	Displayed Message
1139	Warning	UFD Injector 1 Error
1141	Warning	UFD Injector 2 Error
1142	Warning	UFD Injector 3 Error
1143	Warning	UFD Injector 4 Error
1144	Warning	UFD Injector 5 Error
1145	Warning	UFD Injector 6 Error
1213	Shutdown	Compressor Overboost Error
1219	Warning	Utility Breaker Tripped
1223	Warning	Utility Frequency
1224	Warning	Genset Overvoltage
1225	Warning	Genset Undervoltage
1226	Warning	Genset Frequency
1243	Derate	Engine Derated
1244	Shutdown	Engine Normal Shutdown
1245	Shutdown	Engine Shutdown Fault
1246	Warning	Unknown Engine Fault
1247	Shutdown	Unannounced Engine Shutdown
1248	Warning	Engine Warning
1256	Warning	Ctrl Mod ID In State Error
1257	Shutdown	Ctrl Mod ID In State Fail
1274	Shutdown	Heavy Knock Error 10 (B5)
1275	Warning	Knock Cylinder 10 (B5) OOR Low
1276	Warning	Knock Cylinder 10 (B5) OOR High
1277	Warning	Knock Cylinder 11 (A6) OOR Low
1278	Warning	Knock Cylinder 11 (A6) OOR High
1279	Warning	Knock 12 (B6) High
1281	Shutdown	Heavy Knock Error 12 (B6)
1282	Warning	Knock Cylinder 12 (B6) OOR Low
1283	Warning	Knock Cylinder 12 (B6) OOR High
1284	Warning	Knock 13 (B7) High
1285	Shutdown	Continuous Light Knock Error 13 (A7)
1286	Shutdown	Heavy Knock Error 13 (A7)
1287	Warning	Knock Cylinder 13 (A7) OOR Low
1288	Warning	Knock Cylinder 13 (A7) OOR High

Code	Lamp	Displayed Message
1289	Warning	Knock 14 (B7) High Warning
1291	Shutdown	Heavy Knock Error 14 (B7)
1292	Warning	Knock Cylinder 14 (B7) OOR Low
1293	Warning	Knock Cylinder 14 (B7) OOR High
1294	Warning	Knock 15 (A8) High Warning
1295	Shutdown	Continuous Light Knock Error 15 (A8)
1296	Shutdown	Heavy Knock Error 15 (A8)
1297	Warning	Knock Cylinder 15 (A8) OOR Low
1298	Warning	Knock Cylinder 15 (A8) OOR High
1299	Warning	Knock 16 (B8) High Warning
1311	Shutdown	Heavy Knock Error 16 (B8)
1312	Event	Configurable Input # 2
1317	Event	Configurable Input # 13
1318	Event	Configurable Input # 14
1322	Warning	kW Load Setpoint OOR High
1323	Warning	kW Load Setpoint OOR Low
1324	Warning	kVAR Load Setpoint OOR High
1325	Warning	kVAR Load Setpoint OOR Low
1328	Warning	Genset Breaker Tripped
1336	Shutdown	Cooldown Complete
1338	Warning	Knock Cylinder 18 (B9) OOR Low
1339	Warning	Knock Cylinder 18 (B9) OOR High
1352	Warning	Knock 20 (B10) High Warning
1353	Shutdown	Continuous Light Knock Error 20 (B10)
1354	Shutdown	Heavy Knock Error 20 (B10)
1355	Warning	Knock Cylinder 20 (B10) OOR Low
1356	Warning	Knock Cylinder 20 (B10) OOR High
1357	Warning	Oil Remote Level Low
1362	Warning	Oil Filter Restriction Error
1363	Warning	Intake Manf 1 Press Low
1367	Event	High Prefilter Oil Press
1368	Event	Low Prefilter Oil Press
1369	None	Aux Temp 1 Sensor OORH
1373	None	Start Enable Device 1: Cause Unknown

Code	Lamp	Displayed Message
1376	Warning	Camshaft Speed Error
1377	None	Post Oil Filter Pressure OORH
1378	None	Post Oil Filter Pressure OORL
1379	None	Low Fuel Pump Intake Pressure - None severity
1383	None	Intake Manifold 1 Pressure OORH
1384	None	Intake Manifold 1 Pressure OORL
1385	None	Intake Manifold 2 Pressure OORH
1386	None	Intake Manifold 2 Pressure OORL
1389	None	High Fuel Pump Intake Pressure
1411	Warning	High Out Freq Adjust Pot
1412	Warning	High Droop Adjust Pot
1416	Warning	Fail To Shutdown
1417	Warning	Power Down Failure
1418	Warning	High Gain Adjust Pot
1427	Warning	Overspeed Relay Error
1428	Warning	LOP Relay Error
1429	Warning	HET Relay Error
1431	Warning	Pre-LOP Relay Error
1432	Warning	Pre-HET Relay Error
1433	Shutdown	Local Emergency Stop
1434	Shutdown	Remote Emergency Stop
1435	Warning	Low Coolant Temperature
1438	Shutdown	Fail To Crank
1439	Warning	Low Day Tank Fuel Switch
1441	Warning	Low Fuel Level
1442	Shutdown	Weak Battery
1443	Shutdown	Dead Battery
1444	Warning	Overload
1445	Shutdown	Short Circuit
1446	Shutdown	High AC Voltage
1447	Shutdown	Low AC Voltage
1448	Shutdown	Under Frequency
1449	Warning	Over Frequency
1451	Warning	Gen/Bus Voltages Out of Calibration

Code	Lamp	Displayed Message
1452	Warning	Genset Breaker Fail To Close
1453	Warning	Genset Breaker Fail To Open
1454	Warning	Genset Breaker Position Contact
1455	Warning	Utility Breaker Position Contact
1456	Warning	Bus Out Of Synchronizer Range
1457	Warning	Fail To Synchronize
1458	Warning	Sync Phase Rotation Mismatch Overfrequency
1459	Shutdown	Reverse Power
1461	Shutdown	Loss of Field (Reverse kVAR)
1463	Event	Not In Auto
1464	Warning	Load Dump Fault
1465	Event	Ready To Load
1469	Shutdown	Speed/Hz Mismatch
1471	Warning	Over Current
1472	Shutdown	Over Current
1474	Shutdown	ECM Software Mismatch
1475	Warning	First Start Backup
1483	Event	Common Alarm
1517	Shutdown	Failed Module Shutdown
1518	Warning	Failed Module Warning
1519	Warning	At Least One Module Has: Least Severe Fault
1521	Warning	Exhaust Gas Temperature 3 (A2) OOR High
1522	Warning	Exhaust Gas Temperature 5 (A3) OOR High
1523	Warning	Exhaust Gas Temperature 7 (A4) OOR High
1524	Warning	Exhaust Gas Temperature 9 (A5) OOR High
1525	Warning	Exhaust Gas Temperature 11 (A6) OOR High
1526	Warning	Exhaust Gas Temperature 13 (A7) OOR High
1527	Warning	Exhaust Gas Temperature 15 (A8) OOR High
1528	Warning	Exhaust Gas Temperature 17 (A9) OOR High
1529	Warning	Exhaust Gas Temperature 2 (B1) OOR High
1531	Warning	Exhaust Gas Temperature 6 (B3) OOR High
1532	Warning	Exhaust Gas Temperature 8 (B4) OOR High
1533	Warning	Exhaust Gas Temperature 10 (B5) OOR High
1534	Warning	Exhaust Gas Temperature 12 (B6) OOR High

Code	Lamp	Displayed Message
1535	Warning	Exhaust Gas Temperature 14 (B7) OOR High
1536	Warning	Exhaust Gas Temperature 16 (B8) OOR High
1537	Warning	Exhaust Gas Temperature 18 (B9) OOR High
1540	Event	Common Warning
1541	Event	Common Shutdown
1545	Warning	EPS Backup Channel Lost
1546	Warning	EPS Main Channel Lost
1548	Warning	Inj 7 Solenoid Low Curr
1549	Warning	Inj 8 Solenoid Low Curr
1551	Warning	Inj 7 Solenoid Low Curr
1552	Warning	Inj 7 Solenoid Low Curr
1553	Warning	Inj 7 Solenoid Low Curr
1554	Warning	Inj 7 Solenoid Low Curr
1555	Warning	Inj 7 Solenoid Low Curr
1556	Warning	Inj 7 Solenoid Low Curr
1557	Warning	Inj 7 Solenoid Low Curr
1572	Shutdown	Continuous Light Knock Error 19 (A10)
1573	Event	Configurable Input #1
1574	Shutdown	Heavy Knock Error 19 (A10)
1575	Warning	Knock Cylinder 19 (A10) OOR Low
1576	Warning	Knock Cylinder 19 (A10) OOR High
1579	Shutdown	Continuous Light Knock Error 12 (B6)
1581	Shutdown	Continuous Light Knock Error 14 (B7)
1582	Shutdown	Continuous Light Knock Error 16 (B8)
1583	Shutdown	Heavy Knock Error 16 (B8)
1584	Warning	Knock Cylinder 16 (B8) OOR Low
1585	Warning	Knock Cylinder 16 (B8) OOR High
1586	Warning	Knock 17 (A9) High Warning
1587	Shutdown	Continuous Light Knock Error 17 (A9)
1588	Shutdown	Heavy Knock Error 17 (A9)
1589	Warning	Knock Cylinder 17 (A9) OOR Low
1591	Warning	Knock Cylinder 17 (A9) OOR High
1592	Warning	Knock 18 (B9) High Warning
1593	Shutdown	Continuous Light Knock Error 18 (B9)

Code	Lamp	Displayed Message
1594	Warning	Knock 19 (A10) High Warning
1596	None	Aux Temp 1 Sensor OORL
1597	Event	ECM Device/Component
1618	Warning	Exhaust Gas Temperature, Cylinder 1 (A1) OOR High
1619	Warning	Exhaust Gas Temperature, Cylinder 4 (B2) OOR High
1622	Warning	Inj 9 Solenoid Low Curr
1636	Warning	Intake Manifold Pressure 2 OOR High
1637	Warning	Intake Manifold Pressure 2 OOR Low
1664	Warning	Exh Aft Oxidation Catalyst Missing
1665	Warning	Aftertreatment Exhaust Gas Temp1:Volt Below Normal
1666	Warning	Aftertreatment Ext Gas Temp 1:Volt Above Normal
1668	Warning	AT1 DEF Tank Level Sensor OOR Low
1669	Warning	AT1 DEF Tank Level Sensor OOR High
1673	Warning	AT1 Diesel Exhaust Fluid Tank Level Low
1674	Warning	Aftertreatment Exhaust Gas Temp2:Volt Below Normal
1675	Warning	Aftertreatment Exhaust Gas Temp2:Volt Above Normal
1677	Warning	AT1 DEF Tank Temperature Sensor OOR Low
1678	Warning	AT1 DEF Tank Temperature Sensor OOR High
1679	Warning	AT1 Diesel Exhaust Fluid Tank Temperature Error
1682	Warning	AT1 DEF Dosing Unit Input Lines condition
1683	Warning	AT1 Diesel Exhaust Fluid Tank Heater OOR High
1684	Warning	AT1 Diesel Exhaust Fluid Tank Heater OOR Low
1685	Warning	AT Diesel Exhaust Fluid Quality Sensor OOR Low
1686	Warning	AT Diesel Exhaust Fluid Quality Sensor OOR High
1689	Warning	Real Time Clock Power
1691	Warning	Aft Oxidation Catalyst Efficiency: Below Normal
1695	Warning	Sensor Supply 5 High
1696	Warning	Sensor Supply 5 Low
1712	Warning	AT1 Diesel Exhaust Fluid Tank Heater Low
1713	Warning	AT1 Diesel Exhaust Fluid Tank Heater High
1714	Warning	Aftertreatment Diesel Exhaust Fluid Quality Error
1715	Warning	AT Diesel Exhaust Fluid Quality Root unknown
1737	Shutdown	CAN Throttle Internal Failure Error
1738	Warning	CAN Throttle Internal Fault Error

Code	Lamp	Displayed Message
1739	Warning	Engine Throttle Control Condition Exists
1741	Warning	CAN Throttle High Temp Warning Error
1742	Warning	CAN Throttle Temperature Limiting Error
1743	Shutdown	Throttle Control 2 OOR High
1744	Shutdown	Throttle Control 2 OOR Low
1745	Shutdown	Throttle Control 2 Incorrect
1746	Shutdown	Throttle Control 2 Out of Adjustment
1747	Shutdown	Throttle Control 2 Bad Device
1748	Warning	Throttle Control 2 Root Unknown
1749	Warning	Throttle Control 2 Condition Exists
1751	Warning	Throttle Control 2 Warning High
1752	Warning	Throttle Control 2 Moderate High
1753	Warning	Fuel Shutoff 2 OOR High
1754	Warning	Fuel Temperature 2 OOR High
1755	Warning	Fuel Temperature 2 OOR Low
1756	Warning	Gas Flow 2 OOR High
1757	Warning	Gas Flow 2 OOR Low
1758	Warning	Gas Flow 2 Incorrect Data
1759	Shutdown	FCV 2 Positive Feedback Incorrect
1761	Shutdown	FCV Actuator Error
1765	Warning	Engine Gas Control Valve Inlet Pressure 2 OOR High
1766	Warning	Engine Gas Control Valve Inlet Pressure 2 OOR Low
1767	Warning	Engine Gas Control Valve Outlet Pressure 2 OOR High
1768	Warning	Engine Gas Control Valve Outlet Pressure 2 OOR Low
1769	Warning	Engine Emergency Shutdown Indication OOR High
1771	Warning	Engine Emergency Shutdown Indication OOR Low
1772	Warning	Engine Derate Request OOR High
1773	Warning	Engine Derate Request OOR Low
1774	Warning	Oil Priming Pump OOR High
1775	Warning	Oil Priming Pump OOR Low
1778	Warning	Engine Heater Control Driver High Error
1779	Warning	Engine Heater Control Driver Low Error
1781	Warning	Shutdown Request OOR High
1782	Warning	Shutdown Request OOR Low

Code	Lamp	Displayed Message
1783	Warning	Coolant Pump Control Driver High Error
1784	Warning	Coolant Pump Control Driver Low Error
1785	Warning	Oil Priming Pump Manual Override Input On
1786	Warning	Oil Priming Pump Stuck On Error
1787	Warning	Post Lube Oil Priming Error
1788	Warning	Maintenance Lube Oil Priming Error
1789	Shutdown	Pre-start Lube Oil Priming Error
1791	Shutdown	Failure To Meet Load Speed Error
1792	Warning	Idle when Circuit Breaker Closed
1794	Shutdown	Fire Detected
1795	Warning	Compressor Bypass Position High Error
1796	Warning	Compressor Bypass Position Low Error
1797	Warning	Compressor Bypass Control OOR High
1798	Warning	Compressor Bypass Control OOR Low
1799	Warning	Circuit Breaker Position Error Status
1811	Warning	High Side Driver 2 High Control Error (VPS)
1812	Warning	High Side Driver 2 Low Control Error (VPS)
1813	Warning	Valve Proving System Test Failed Warning Error
1814	Shutdown	Valve Proving System Test Failed Shutdown Error
1815	Warning	RLY14 High Control Error
1816	Warning	Oil Pre-heater Control OOR Low
1817	Warning	Oil Pre-heater Tripped Error
1818	Warning	Oil Pre-heater Not Warming Error
1819	Warning	Common AC Aux Circuit Breaker Tripped
1821	Shutdown	Minimum FSO Speed Error
1822	Shutdown	LT Coolant Level Low Shutdown Error
1823	Warning	LT Coolant Level Low Warning Error
1824	Warning	Idle Rated Trans Oil Temperature Low Error
1825	Warning	Dirty Oil Level Error
1826	Shutdown	ECM Software Incompatible
1827	Warning	Fuel Inlet Pressure High Error
1828	Warning	Fuel Inlet Pressure Low Error
1829	Shutdown	Vent Gas Valve Error
1831	Shutdown	Upstream FSO Valve Error

Code	Lamp	Displayed Message
1832	Shutdown	Downstream FSO Valve Error
1833	Warning	Engine Heater Trip Error
1834	Warning	Coolant Pump Trip Error
1835	Warning	Oil Priming Pump Tripped Error
1836	Shutdown	LCP (LT) Low Serious Error
1837	Shutdown	Permanent FS Cam Sync Lost Error
1838	Shutdown	Partial Engine Overload Shutdown Error
1839	Warning	Fuel Supply Pressure High Error
1841	Warning	Fuel Supply Pressure Low Error
1842	Warning	Radiator Fan Trip Error
1843	Warning	Crankcase Press High
1844	Warning	Crankcase Press Low
1845	Warning	H2O In Fuel Sens High
1846	Warning	H2O In Fuel Sens Low
1847	Shutdown	Eng Coolant Temp - Shutdown w/Cool
1852	Warning	Pre-High H2O In Fuel
1853	Event	Annunciator Input 1 Fault
1854	Event	Annunciator Input 2 Fault
1855	Event	Annunciator Input 3 Fault
1858	Warning	Exhaust After Inlet O2 OOR High
1859	Warning	Exhaust After Inlet O2 OOR Low
1861	Warning	Exhaust After Inlet O2 Incorrect
1862	Warning	Exhaust After Outlet O2 OOR High
1863	Warning	Exhaust After Outlet O2 OOR Low
1864	Warning	Exhaust After Outlet O2 Incorrect
1866	Warning	EGR DP Autozero Error
1867	Warning	Exhaust Gas Recirculation Temperature Error
1879	Warning	Aft Particulate Filter Pressure OORH
1881	Warning	Aft Particulate Filter Pressure OORL
1883	Warning	Aft Particulate Filter Pressure: Incorrect
1885	Warning	Aftertreatment 1Intake NoxSensor:Volt Below Normal
1887	Warning	AT1 Outlet NOx Sensor Circuit OOR Low
1891	Warning	Change Oil
1893	Warning	CAN EGR Valve Comm

Code	Lamp	Displayed Message
1894	Warning	CAN VGT Comm Error
1895	Warning	EGA DL Mismatch Error
1896	Warning	EGR DL Valve Stuck
1898	Warning	VGT Actuator Controller Out of Calibration
1899	Warning	Low EGR Dif Pressure
1911	Warning	Inj Metering 1 Press High
1912	Warning	Utility Loss Of Phase
1913	Warning	Genset Loss Of Phase
1914	Warning	Utility Phase Rotation
1915	Warning	Genset Phase Rotation
1916	Event	Sync Check OK
1917	Warning	Fuel Level High
1918	Shutdown	Fuel Level Low
1921	Warning	Aftertreatment DPF Differential Pressure
1922	Shutdown	Aftertreatment DPF Differential Pressure Severe
1933	Warning	High EGR Data Link Volt
1934	Warning	Low EGR Data Link Volt
1935	Warning	EGR DL Cmd Source Err
1938	Warning	ECU Power Output Volt: Below Normal
1942	Warning	THD AZ Error
1943	Event	CBR Density Derate Error ID
1944	Warning	HMI 113 Out Config Error
1961	Warning	High EGR DL EDU Temp
1962	Warning	VGT Actuator Driver Temperature: Above Normal
1965	Warning	Aftertreatment Ext Gas Temp1:Data Above Normal
1966	Shutdown	Aftertmt Ext Gas Temp1:Above Normal-Most Severe
1968	Warning	Aftertmt Ext Gas Temp2:Above Normal-Severe
1969	Shutdown	Aftertmt Ext Gas Temp2:Above Normal-Most Severe
1974	Warning	Crankcase Press High
1978	Warning	Speed Bias OOR High
1979	Warning	Speed Bias OOR Low
1982	Shutdown	Catalyst Over Temp:Data Above Normal - Most Severe
1983	Warning	Catalyst Over Temperature Data Above Normal Severe
1984	Warning	Int Man 2 Tmp Moderate High

Code	Lamp	Displayed Message
1985	Warning	Int Man 3 Temperature Moderate High
1986	Warning	Int Man 4 Temperature Moderate High
1992	Shutdown	Crankcase Sensor High
1993	Warning	Aft Particulate Filter Missing
1999	Warning	Maximum Parallel Time
2111	Warning	Coolant Inlet Temperature (LT) High Error
2112	Warning	Coolant Inlet Temperature (LT) Low Error
2113	Warning	CIT (LT) High Warning Error
2114	Shutdown	CIT (LT) High Serious Error
2115	Warning	LT Coolant Pressure High Error
2116	Warning	LT Coolant Pressure Low Error
2117	Warning	LCP (LT) Low Warning Error
2118	Warning	Low Fuel Pressure
2121	Warning	Exhaust Temperature 1 (A1) High Warning Error
2122	Warning	Exhaust Temperature 3 (A2) High Warning Error
2123	Warning	Exhaust Temperature 5 (A3) High Warning Error
2124	Warning	Exhaust Temperature 7 (A4) High Warning Error
2125	Warning	Exhaust Temperature 9 (A5) High Warning Error
2126	Warning	Exhaust Temperature 11 (A6) High Warning Error
2127	Warning	Exhaust Temperature 13 (A7) High Warning Error
2128	Warning	Exhaust Temperature 15 (A8) High Warning Error
2129	Warning	Exhaust Temperature 17 (A9) High Warning Error
2131	Warning	Exhaust Temperature 2 (B1) High Warning Error
2132	Warning	Exhaust Temperature 4 (B2) High Warning Error
2133	Warning	Exhaust Temperature 6 (B3) High Warning Error
2134	Warning	Exhaust Temperature 8 (B4) High Warning Error
2135	Warning	Exhaust Temperature 10 (B5) High Warning Error
2136	Warning	Exhaust Temperature 12 (B6) High Warning Error
2137	Warning	Exhaust Temperature 14 (B7) High Warning Error
2138	Warning	Exhaust Temperature 16 (B8) High Warning Error
2139	Warning	Exhaust Temperature 18 (B9) High Warning Error
2141	Warning	Start Air Pressure High Error
2142	Warning	Start Air Pressure Low Error
2143	Warning	SAP Overpressure Error

Code	Lamp	Displayed Message
2144	Shutdown	Exhaust Temperature 16 (B8) High Serious Error
2145	Shutdown	Exhaust Temperature 18 (B9) High Serious Error
2146	Warning	EGT 17 (A9) OOR Low
2147	Warning	EGT 18 (B9) OOR Low
2154	Warning	Oil Filter Outlet Pressure High Error
2155	Warning	Oil Filter Outlet Pressure Low Error
2157	Shutdown	Int Man 2 Temp Abnormal Rate
2158	Shutdown	Int Man 3 Tmp Abnormal Rate
2159	Shutdown	Int Man 4 Tmp Abnormal Rate
2184	Warning	Fuel Injection Control Valve Root Cause Unknown
2185	Warning	Sensor Supply 4 High
2186	Warning	Sensor Supply 4 Low
2188	Warning	Exhaust O2 OOR High
2191	Warning	ST Throttle Pressure Error Status
2192	Warning	Exhaust O2 OOR Low
2193	Warning	HT Coolant Level Moderate High
2198	Warning	VGT Actuator Driver Circuit: Unknown Cause
2215	Warning	Fuel Pump Press Low
2217	Warning	RAM Image Word Error
2219	Warning	Exhaust O2 Moderate High
2221	Warning	Exhaust O2 Moderate Low
2231	Warning	Knock Cylinder 1 (A1) OOR High
2232	Warning	Knock Cylinder 2 (B1) OOR High
2233	Warning	Knock Cylinder 3 (A2) OOR High
2234	Warning	Knock Cylinder 4 (B2) OOR High
2235	Warning	Knock Cylinder 5 (A3) OOR High
2236	Warning	Knock Cylinder 6 (B3) OOR High
2237	Warning	Knock Cylinder 7 (A4) OOR High
2238	Warning	Knock Cylinder 8 (B4) OOR High
2239	Warning	Knock Cylinder 9 (A5) OOR High
2249	Warning	APC 2 Pressure Low
2261	Warning	Fuel Pump Press High
2262	Warning	Fuel Pump Press Low
2265	Warning	High Fuel Lift Pump Volt

Code	Lamp	Displayed Message
2266	Warning	Low Fuel Lift Pump Volt
2272	Warning	EGR DL POS Sensor Error
2273	Warning	EGR Delta P OOR High Error
2274	Warning	EGR Delta P OOR Low Error
2279	Warning	Knock 11 (A6) High Warning
2281	Shutdown	Knock 11 (A6) Moderate Warning
2282	Shutdown	Knock 11 (A6) Critical Warning
2288	None	Turbo Charger 1 Speed: Above Normal
2292	Warning	APC Flow high
2293	Warning	APC Flow Low
2298	Warning	Fuel Shutoff 2 OOR Low
2311	Warning	EFI Control Valve Fail
2313	Warning	Fuel Control Valve Error
2315	Warning	Red Lamp OOR High
2316	Warning	Amber Lamp OOR High
2317	Warning	Amber Lamp OOR Low
2328	Event	Utility Available
2331	Warning	Utility Undervoltage
2332	Event	Utility Connected
2333	Event	Genset Connected
2335	Shutdown	AC Voltage Sensing Lost (Excitation Fault)
2336	Shutdown	Checksum Fault
2342	Warning	Too Long In Idle
2343	None	Fuel Filter Press Hi Above Normal
2346	Event	CBR TFC Derate Error ID
2349	Warning	EGR DL Motor Open Error
2351	Warning	EGR DL Motor Short Error
2353	Warning	EGR Valve Control Circuit: Current OORH
2357	Warning	EGR DL Motor Lock Error
2358	Warning	Utility Overvoltage
2359	Warning	EGR Delta P IR High Error
2372	Warning	Fuel Filter Pressure: Above Normal
2373	Warning	Exhaust Pressure: OORH
2374	Warning	Exhaust Pressure: OORL

Code	Lamp	Displayed Message
2375	Warning	EGR Orifice TMPTR OOR High Error
2376	Warning	EGR Orifice TMPTR OOR Low Error
2377	Warning	High Fan Control Voltage
2387	Warning	VGT Actuator: Mechanical Sys Not Responding
2396	Warning	Utility Breaker Fail To Close
2397	Warning	Utility Breaker Fail To Open
2412	Shutdown w/Cooldown	Fan Speed Error
2427	Warning	Fuel Outlet Pressure High Error
2428	Warning	Fuel Outlet Pressure Low Error
2431	Warning	Knock 1 (A1) High Warning
2432	Warning	Knock 2 (B1) High Warning
2433	Warning	Knock 3 (A2) High Warning
2434	Warning	Knock 4 (B2) High Warning
2435	Warning	Knock 5 (A3) High Warning
2436	Warning	Knock 6 (B3) High Warning
2437	Warning	Knock 7 (A4) High Warning
2438	Warning	Knock 8 (B4) High Warning
2439	Warning	Knock 9 (A5) High Warning
2441	Warning	Knock 10 (B5) High Warning
2442	Warning	Inj Solenoid Driver 1 Calib Error
2443	Warning	Inj Solenoid Driver 2 Calib Error
2444	Warning	Inj Solenoid Driver 3 Calib Error
2445	Warning	Inj Solenoid Driver 4 Calib Error
2446	Warning	Inj Solenoid Driver 5 Calib Error
2447	Warning	Inj Solenoid Driver 6 Calib Error
2448	Warning	Coolant Level Moderately Low
2449	Shutdown	VGT Actuator Controller: Out of Calibration
2453	Warning	Total Real Power Circuit OOR High
2454	Warning	Total Real Power Circuit OORL
2455	Warning	Speed Bias Low Error
2456	Warning	Speed Bias High Error
2457	Shutdown	Max Total Misfire Error
2458	Warning	Cylinder 2 (B1) Total Misfire Error

Code	Lamp	Displayed Message
2459	Warning	Cylinder 4 (B2) Total Misfire Error
2461	Warning	Cylinder 6 (B3) Total Misfire Error
2462	Warning	Cylinder 8 (B4) Total Misfire Error
2463	Warning	Cylinder 10 (B5) Total Misfire Error
2464	Warning	Cylinder 12 (B6) Total Misfire Error
2465	Warning	Cylinder 14 (B7) Total Misfire Error
2466	Warning	Cylinder 16 (B8) Total Misfire Error
2467	Warning	Cylinder 18 (B9) Total Misfire Error
2469	Warning	Cylinder 1 (A1) Total Misfire Error
2471	Warning	Cylinder 3 (A2) Total Misfire Error
2472	Warning	Cylinder 5 (A3) Total Misfire Error
2473	Warning	Cylinder 7 (A4) Total Misfire Error
2475	Warning	Cylinder 9 (A5) Total Misfire Error
2476	Warning	Cylinder 11 (A6) Total Misfire Error
2477	Warning	Cylinder 13 (A7) Total Misfire Error
2478	Warning	Cylinder 15 (A8) Total Misfire Error
2479	Warning	Cylinder 17 (A9) Total Misfire Error
2482	Shutdown	Start Before Ready Error
2483	Shutdown	Continuous Starter Failure Error
2484	Shutdown	Exhaust Temperature 1 (A1) Abnormal Rate
2485	Shutdown	Exhaust Temperature 3 (A2) Abnormal Rate
2486	Shutdown	Exhaust Temperature 5 (A3) Abnormal Rate
2487	Shutdown	Exhaust Temperature 7 (A4) Abnormal Rate
2488	Shutdown	Exhaust Temperature 9 (A5) Abnormal Rate
2489	Shutdown	Exhaust Temperature 11 (A6) Abnormal Rate
2491	Shutdown	Exhaust Temperature 13 (A7) Abnormal Rate
2492	Shutdown	Exhaust Temperature 15 (A8) Abnormal Rate
2493	Shutdown	Exhaust Temperature 17 (A9) Abnormal Rate
2494	Shutdown	Exhaust Temperature 2 (B1) Abnormal Rate
2495	Shutdown	Exhaust Temperature 4 (B2) Abnormal Rate
2496	Shutdown	Exhaust Temperature 6 (B3) Abnormal Rate
2497	Shutdown	Exhaust Temperature 8 (B4) Abnormal Rate
2498	Shutdown	Exhaust Temperature 10 (B5) Abnormal Rate
2499	Shutdown	Exhaust Temperature 12 (B6) Abnormal Rate

Code	Lamp	Displayed Message
2511	Shutdown	Exhaust Temperature 14 (B7) Abnormal Rate
2512	Shutdown	Exhaust Temperature 16 (B8) Abnormal Rate
2513	Shutdown	Exhaust Temperature 18 (B9) Abnormal Rate
2514	Shutdown	Exhaust Temperature 19 (A10) Abnormal Rate
2515	Shutdown	Exhaust Temperature 20 (B10) Abnormal Rate
2517	Warning	Compressor Outlet Pressure High Error
2518	Warning	Compressor Outlet Pressure Low Error
2521	Shutdown	Bank ID Error
2522	Shutdown	Continuous Light Knock Error 1 (A1)
2523	Shutdown	Continuous Light Knock Error 2 (B1)
2524	Shutdown	Continuous Light Knock Error 3 (A2)
2525	Shutdown	Continuous Light Knock Error 4 (B2)
2526	Shutdown	Continuous Light Knock Error 5 (A3)
2527	Shutdown	Continuous Light Knock Error 6 (B3)
2528	Shutdown	Continuous Light Knock Error 7 (A3)
2529	Shutdown	Continuous Light Knock Error 8 (B4)
2531	Shutdown	Continuous Light Knock Error 9 (A5)
2532	Shutdown	Continuous Light Knock Error 10 (B5)
2539	Warning	High Voltage Bias
2541	Warning	Low Voltage Bias
2544	Shutdown w/Cooldown	ECM Overtemp Error
2545	Warning	Keysw Reset Required
2553	Warning	Engine Oil Level Low Warning Error
2554	Warning	Exhaust Gas Pressure: Incorrect
2555	Warning	Low GHC 1 Voltage
2556	Warning	High GHC 1 Voltage
2557	Warning	Auxiliary PWM Driver 1 Circuit OOR High
2558	Warning	Auxiliary PWM Driver 1 Circuit OOR Low
2567	Warning	DG Air Compressor Trip Error
2568	Shutdown	Gas Supply Pressure Critical High
2569	Shutdown	Gas Supply Pressure Critical Low
2586	Event	Spark Plug 1 (A1) High Warning
2587	Event	Spark Plug 2 (B1) High Warning

Code	Lamp	Displayed Message
2588	Event	Spark Plug 3 (A2) High Warning
2589	Event	Spark Plug 4 (BS) High Warning
2591	Event	Spark Plug 5 (A3) High Warning
2592	Event	Spark Plug 6 (B3) High Warning
2593	Event	Spark Plug 1 (A1) Low Warning
2594	Event	Spark Plug 2 (B1) Low Warning
2595	Event	Spark Plug 3 (A2) Low Warning
2596	Event	Spark Plug 4 (B2) Low Warning
2597	Event	Spark Plug 5 (A3) Low Warning
2598	Event	Spark Plug 6 (B3) Low Warning
2619	Warning	Aux101 0 Input 1 Fault
2621	Warning	Aux101 0 Input 2 Fault
2622	Warning	Aux101 0 Input 3 Fault
2623	Warning	Aux101 0 Input 4 Fault
2624	Warning	Aux101 0 Input 5 Fault
2625	Warning	Aux101 0 Input 6 Fault
2626	Warning	Aux101 0 Input 7 Fault
2627	Warning	Aux101 0 Input 8 Fault
2628	Warning	Aux102 0 Expansion Input 9 Fault
2629	Warning	Aux102 0 Expansion Input 10 Fault
2631	Warning	Aux102 0 Expansion Input 11 Fault
2632	Warning	Aux102 0 Expansion Input 12 Fault
2634	Shutdown	VGT Actuator Controller: Bad Device/Component
2635	Shutdown	VGT Actuator Driver Condition Exists
2636	Shutdown	VGT Actuator Circuit: Abnormal Update Rate
2637	None	Aft Catalyst Face Plugged: Reason Unknown
2639	None	Aftertreatment DPF Differential Press Least Severe
2643	Warning	Throttle Position 2 Feedback OOR High
2644	Warning	Throttle Position 2 Feedback OOR Low
2646	Warning	HT Coolant Temperature Condition Exists
2651	None	Exhaust Gas Temperature Right Manifold: OORH
2652	None	Exhaust Gas Temperature Right Manifold: OORL
2653	Warning	Exhaust St 2 Temp High
2654	Shutdown	Exhaust Stack Temp Right Bank Above Sh Threshold

Code	Lamp	Displayed Message
2655	None	Exhaust Gas Temperature Left Manifold: OORH
2656	None	Exhaust Gas Temperature Left Manifold: OORL
2657	Warning	Exhaust St 1 Temp High
2658	Shutdown	Exhaust Stack Temp Left Bank Above Sh Threshold
2661	Shutdown	At Least One Unacknowledged Most Severe Fault 0 Condition Exists
2662	Warning	At Least One acknowledged: Most Severe Fault
2677	Shutdown	Fail To Stop
2678	Warning	Charging Alternator Fail
2724	Warning	Gas Supply Pressure Moderate High
2725	Warning	Gas Supply Pressure Moderate Low
2727	Warning	Critical CEN Not Accessible Error
2737	Shutdown	Exhaust Gas Temperature Critical High
2738	Warning	Ether INJ Low CTRL Error
2739	Warning	Ether INJ High CTRL Error
2752	Shutdown	Throttle Actuator - Shorted High
2753	Shutdown	Exhaust Gas Recirculation Temp: Above Normal
2754	Warning	Diesel Particulate Filter Int Press: Above Normal
2765	None	Engine Inj Bank 1 Barcode: Out Of Calibration
2766	Shutdown	Bank A CCD Failed Error
2767	Shutdown	Bank B CCD Failed Error
2768	Shutdown	CAN Parent Communication Incorrect
2769	Shutdown	CAN Child Communication Incorrect
2771	Warning	Aftertreatment 1 Outlet NOx Sensor Abnormal
2774	Warning	EGR DP Clogged Tubes Error
2777	None	Particulate Trap Regen Inhibit: Condition Exists
2779	Event	Utility Unloaded Event
2789	Warning	COT Low Error
2793	Shutdown	COT Low Serious Error
2794	Warning	Ignition Shutdown Relay OOR High
2795	Warning	Ignition Shutdown Relay OOR Low
2796	Warning	Partial Engine Overload Warning Error
2797	Warning	Inlet Gas Diff Pressure OOR High
2798	Warning	Inlet Gas Diff Pressure OOR Low
2799	Shutdown	IMOP Compressor Outlet Pressure Delta Error

Code	Lamp	Displayed Message
2811	Shutdown	IMOP Compressor Outlet Pressure Maximum Error
2812	Shutdown	Throttle Control Actuator Error
2814	Shutdown	Genset CT Ratio Low
2815	Warning	Genset CT Ratio High
2816	Shutdown	Genset PT Ratio Low
2817	Warning	Genset PT Ratio High
2818	Shutdown	Bus PT Ratio Low
2819	Warning	Bus PT Ratio High
2821	Warning	Utility PT Ratio Low
2822	Warning	Utility PT Ratio High
2837	Warning	Exhaust Temperature 1 (A1) Deviation Error
2838	Warning	Exhaust Temperature 3 (A2) Deviation Error
2839	Warning	Exhaust Temperature 5 (A3) Deviation Error
2841	Warning	Exhaust Temperature 7 (A4) Deviation Error
2842	Warning	Exhaust Temperature 9 (A5) Deviation Error
2843	Warning	Exhaust Temperature 11 (A6) Deviation Error
2844	Warning	Exhaust Temperature 13 (A7) Deviation Error
2845	Warning	Exhaust Temperature 15 (A8) Deviation Error
2846	Warning	Exhaust Temperature 17 (A9) Deviation Error
2847	Warning	Exhaust Temperature 2 (B1) Deviation Error
2848	Warning	Exhaust Temperature 4 (B2) Deviation Error
2849	Warning	Exhaust Temperature 6 (B3) Deviation Error
2851	Warning	Exhaust Temperature 8 (B4) Deviation Error
2852	Warning	Exhaust Temperature 10 (B5) Deviation Error
2853	Warning	Exhaust Temperature 12 (B6) Deviation Error
2854	Warning	Exhaust Temperature 14 (B7) Deviation Error
2855	Warning	Exhaust Temperature 16 (B8) Deviation Error
2856	Warning	Exhaust Temperature 18 (B9) Deviation Error
2857	Shutdown	Turbo 1 Overspeed Critical Error
2858	Shutdown	Turbo 2 Overspeed Critical Error
2859	Warning	Alt Heater ctrl OOR High
2861	Warning	Alt Heater ctrl OOR Low
2862	Warning	Gen Alternator 1st Start Cond Exists
2863	Shutdown	Genset to Engine Com Incorrect

Code	Lamp	Displayed Message
2864	Shutdown	FSO NON High Control Error
2866	Warning	FCV Position High Error
2867	Warning	FCV Position Low Error
2868	Warning	Engine Heater Over-Temperature Alarm Error
2869	Warning	HT Cool Temp Driver OOR High
2871	Warning	HT Cool Temp Driver OOR Low
2872	Warning	HT Cool Temp Driver Cond Exists
2873	Warning	LT Cool Temp Driver OOR High
2874	Warning	LT Cool Temp Driver OOR Low
2875	Warning	LT Cool Temp Driver Cond Exists
2876	Shutdown	Comp Surge Shutdown Error
2877	Warning	Comp Surge Derate Error
2882	Warning	Aux101 1 Input 1 Fault
2883	Warning	Aux101 1 Input 2 Fault
2884	Warning	Aux101 1 Input 3 Fault
2885	Warning	Aux101 1 Input 4 Fault
2886	Warning	Aux101 1 Input 5 Fault
2887	Warning	Aux101 1 Input 6 Fault
2888	Warning	Aux101 1 Input 7 Fault
2889	Warning	Aux101 1 Input 8 Fault
2891	Warning	Aux102 1 Expansion Input 9 Fault
2892	Warning	Aux102 1 Expansion Input 10 Fault
2893	Warning	Aux102 1 Expansion Input 11 Fault
2894	Warning	Aux102 1 Expansion Input 12 Fault
2895	Warning	PCCNet Device Failed
2896	Shutdown	Critical PCCNet Dev Fail
2912	Shutdown	Voltage Reconnection Switch Operated
2913	Warning	Reconnection Switch Operated
2914	Shutdown	Genset AC Meter Failed
2915	Warning	Gen Bus AC Meter Failed
2916	Warning	Utility AC Meter Failed
2917	Warning	Gen Bus Voltage OOR Hi
2918	Warning	Utility Voltage OOR Hi
2919	Warning	Utility Current OOR Hi

Code	Lamp	Displayed Message
2921	Warning	Gen Bus Current OOR Hi
2922	Warning	High Genset Neutral Curr
2923	Warning	Gen Bus kW OOR Hi
2924	Warning	Gen Bus kVAR OOR Hi
2925	Warning	Gen Bus kVA OOR Hi
2926	Warning	Utility kW OOR Hi
2927	Warning	Utility kVAR OOR Hi
2928	Warning	Utility kVA OOR Hi
2931	Shutdown	Aux101 Device ID Fault
2932	Warning	Aux101 Oil Temperature OOR Hi
2933	Warning	Aux101 Oil Temperature OOR Low
2934	Warning	High Ambient Temp
2935	Warning	Low Ambient Temp
2936	Warning	Fuel Level High
2937	Warning	Fuel Level Low
2938	Warning	Earth/Ground Fault
2939	Warning	Modbus Failure
2941	Event	Remote Shutdown Fault Reset Occurrence
2942	Warning	Shutdown Override Fail
2943	Warning	Manual Sw Config Fail
2944	Warning	Auto Switch Config Fail
2945	Warning	Rupture Basin Switch
2946	Warning	Exhaust St 2 Temp Low
2947	Warning	Exhaust St 1 Temp Low
2948	Warning	Exhaust St 2 Temp High
2949	Warning	Exhaust St 1 Temp High
2951	Warning	Alternator 1 Temp High
2952	Warning	Alternator 1 Temp Low
2953	Warning	Alternator 1 Temp High
2954	Warning	Alternator 2 Temp High
2955	Warning	Alternator 2 Temp Low
2956	Warning	Alternator 2 Temp High
2957	Warning	Alternator 3 Temp High
2958	Warning	Alternator 3 Temp Low

Code	Lamp	Displayed Message
2959	Warning	Alternator 3 Temp High
2961	Event	EGR Torque Derate Error
2962	Warning	EGR RPM Derate Error
2963	Event	HT Coolant Temperature Warning High
2964	Warning	Pre-high Intake Manifold Temperature
2965	Event	Genset Available
2971	Event	Test/Exercise Fault
2972	Shutdown	Field Overload
2973	Warning	Charge Press IR Error
2976	Warning	AT1 Diesel Exhaust Fluid Dosing Unit Temp. Error
2977	Warning	Low Coolant Level 2 Sw
2978	Warning	Low Intake Manf 1 Temp
2979	Warning	High Alternator Temp Sw
2981	Warning	High Drive Bearing Temp
2982	Warning	Low Drive Bearing Temp
2983	Warning	High Drive Bearing Temp
2984	Warning	High Free Bearing Temp
2985	Warning	Low Free Bearing Temp
2986	Warning	High Free Bearing Temp
2992	Warning	High Intake Manf 1 Temp
2993	Warning	Battery Charger Sw Fail
2994	Shutdown	MC68302 Error
2995	Shutdown	Int Man Pressure 1 Critical High
2996	Shutdown	Int Man Pressure 1 Moderate High
2997	Shutdown	Exhaust O2 Critical Low
2998	Warning	Engine Torque Limit Feature Special Instructions
3111	Shutdown	Excessive Mech Vibration 1 (A1)
3112	Shutdown	Excessive Mech Vibration 2 (B1)
3113	Shutdown	Excessive Mech Vibration 3 (A2)
3114	Shutdown	Excessive Mech Vibration 4 (B2)
3115	Shutdown	Excessive Mech Vibration 5 (A3)
3116	Shutdown	Excessive Mech Vibration 6 (B3)
3117	Shutdown	Excessive Mech Vibration 7 (A4)
3118	Shutdown	Excessive Mech Vibration 8 (B4)

Code	Lamp	Displayed Message
3119	Shutdown	Excessive Mech Vibration 9 (A5)
3121	Shutdown	Excessive Mech Vibration 10 (B5)
3122	Shutdown	Excessive Mech Vibration 11 (A6)
3123	Shutdown	Excessive Mech Vibration 12 (B6)
3124	Shutdown	Excessive Mech Vibration 13 (A7)
3125	Shutdown	Excessive Mech Vibration 14 (B7)
3126	Shutdown	Excessive Mech Vibration 15 (A8)
3127	Shutdown	Excessive Mech Vibration 16 (B8)
3128	Shutdown	Excessive Mech Vibration 17 (A9)
3129	Shutdown	Excessive Mech Vibration 18 (B9)
3131	Shutdown	Secondary Engine Overspeed
3133	Warning	Aftertreatment Particulate Filter Outlet Pressure OOR High
3134	Warning	Aft Particulate Filter Outlet Pressure: OORL
3135	Warning	Aft Particulate Filter Pressure: Data Eratic
3139	Warning	ASO Solenoid out of range high
3142	Warning	AT1 SCR Intake Temp. Sensor Circuit OOR High
3143	Warning	AT1 SCR Intake Temp. Sensor Circuit OOR Low
3144	Warning	AT1 SCR Intake Temperature Sensor Error
3146	Warning	AT1 SCR Outlet Temp. Sensor Circuit OOR High
3147	Warning	AT1 SCR Outlet Temp. Sensor Circuit OOR Low
3148	Warning	AT1 SCR Outlet Temperature Sensor Error
3151	Warning	AT1 SCR Catalyst System Missing Condition
3165	Shutdown	Aftertreatment 1 SCR Outlet Temperature High
3173	Warning	AT1 Warm Up DOCE Low
3226	Event	Base Load
3227	Event	Peak Shave
3228	Warning	Aftertreatment Intake Nox Sensor: Data Incorrect *
3229	Shutdown	AT1 SCR Intake Temp. High - Most Severe Level
3231	Shutdown w/Cooldown	AT1 SCR Intake Temp. High - Moderate Severe Level
3232	Warning	Aftertreatment Intake Nox Sensor:Abnormal Update *
3235	Shutdown w/Cooldown	AT1 SCR Outlet Temperature High
3237	Warning	AT1 DEF Line Heater 1 Circuit OOR High
3238	Warning	AT1 DEF Line Heater 1 Circuit OOR Low

Code	Lamp	Displayed Message
3239	Warning	AT1 DEF Line Heater 2 Circuit OOR High
3241	Warning	AT1 DEF Line Heater 2 Circuit OOR Low
3242	Warning	AT1 DEF Tank Heater Mechanical System Error
3245	Warning	Aft Particulate Filter System: Not Responding *
3251	Shutdown	Aft Catalyst Intake Temp:Data Valid:Above Normal *
3253	Shutdown	Particulate Filter Int Temp: Above Normal Mod Sev *
3254	Warning	Particulate Filter Int Temp: Above Normal *
3255	Shutdown	Particulate Filter Out Temp: Above Normal Mod Sev
3256	Warning	Particulate Filter Outlet Temp: Above Normal
3258	Warning	AT1 DEF Line Heater 1 Open Circuit
3261	Warning	AT1 DEF Line Heater 2 Open Circuit
3262	Event	Spark Plug 7 (A4) High Warning
3263	Event	Spark Plug 7 (A4) Low Warning
3264	Event	Spark Plug 8 (B4) High Warning
3265	Event	Spark Plug 8 (B4) Low Warning
3266	Event	Spark Plug 9 (A5) High Warning
3267	Event	Spark Plug 9 (A5) Low Warning
3268	Event	Spark Plug 10 (B5) High Warning
3269	Event	Spark Plug 10 (B5) Low Warning
3271	Event	Spark Plug 11 (A6) High Warning
3272	Event	Spark Plug 11 (A6) Low Warning
3273	Event	Spark Plug 12 (B6) High Warning
3274	Event	Spark Plug 12 (B6) Low Warning
3275	Event	Spark Plug 13 (A7) High Warning
3276	Event	Spark Plug 13 (A7) Low Warning
3277	Event	Spark Plug 14 (B7) High Warning
3278	Event	Spark Plug 14 (B7) Low Warning
3279	Event	Spark Plug 15 (A8) High Warning
3281	Event	Spark Plug 15 (A8) Low Warning
3282	Event	Spark Plug 16 (B8) High Warning
3283	Event	Spark Plug 16 (B8) Low Warning
3284	Event	Spark Plug 17 (A9) High Warning
3285	Event	Spark Plug 17 (A9) Low Warning
3286	Event	Spark Plug 18 (B9) High Warning

Code	Lamp	Displayed Message
3287	Event	Spark Plug 18 (B9) Low Warning
3288	Warning	Exhaust Aftertreatment Outlet Oxygen Relay OOR High
3289	Warning	Exhaust Aftertreatment Outlet Oxygen Relay OOR Low
3291	Warning	Exhaust Aftertreatment Inlet Oxygen Relay OOR High
3292	Warning	Exhaust Aftertreatment Inlet Oxygen Relay OOR Low
3293	Warning	Exhaust Oxygen Relay OOR High
3294	Warning	Exhaust Oxygen Relay OOR Low
3311	Shutdown	Particulate Filter Int Temp: Above Normal Severe
3312	Shutdown	Particulate Filter Out Temp: Above Normal Severe
3313	Warning	Aft Catalyst Intake Temperature: Below Normal
3314	Warning	Aft Catalyst Intake Temperature: Above Normal
3315	Warning	Aft Catalyst Intake Temperature: Incorrect
3316	Warning	Aft Particulate Filter Intake Temperature: OORL
3317	Warning	Aft Particulate Filter Intake Temperature: OORH
3318	Warning	Aft Particulate Filter Intake Temp: Data Incorrect
3319	Warning	Aft Particulate Filter Outlet Temp Circuit: OORH
3321	Warning	Aft Particulate Filter Outlet Temp Circuit: OORL
3322	Warning	Aft Particulate Filter Outlet Temp: Data Incorrect
3325	Warning	Aft Catalyst Intake Temp Swapped: Out Of Cal
3329	None	J1939 Network 2 Data Incorrect
3331	None	J1939 Network 3 Data Incorrect
3341	Warning	Engine Air Filter Differential Pressure High
3362	Warning	Power Conservation Control OOR High
3363	Warning	Power Conservation Control OOR Low
3364	Warning	Power Conservation Control Cond Exists
3365	Warning	External Air Pressure Low Warning Error
3384	Warning	Manifold Absolute Pressure 2 High Error
3391	Warning	Manifold Absolute Pressure 2 Low Error
3392	Shutdown	Int Man Pressure 2 Critical High
3393	Warning	Int Man Pressure 2 Moderate High
3396	Warning	DPF 1 Conditions Not Met for Active Regeneration
3397	Shutdown	Low Gearbox Oil Pressure – Condition Exists
3398	Shutdown	High Gearbox Oil Pressure – Condition Exists
3399	Shutdown	Differential Fault – Condition Exists

Code	Lamp	Displayed Message
3411	Warning	DC Power Supply Fault – Condition Exists
3412	Warning	GIB Isolator Open Fault – Condition Exists
3413	Warning	Radiator Fan Trip Fault – Condition Exists
3414	Warning	Ventilator Fan Trip Fault – Condition Exists
3415	Warning	Louvres Closed Fault – Condition Exists
3416	Warning	Start System Fault – Condition Exists
3417	Warning	Alternator Heater Trip Fault – Condition Exists
3422	Warning	AT DEF Line Heater 3 Circuit OOR High
3423	Warning	AT DEF Line Heater 3 Circuit OOR Low
3425	Warning	AT DEF Line Heater 3 Open Circuit
3457	Warning	Loss of Bus Voltage Sensing
3458	Warning	Knock Engine Derate
3475	Warning	Engine Electronic Fuel Valve #2 OOR High
3476	Warning	Engine Electronic Fuel Valve #2 OOR Low
3477	Warning	Fuel Actuator 2 Control Valve: Out of Adjustment
3478	Warning	Engine Charge Air Cooler Outlet Temperature Error
3479	Shutdown	Start-Inhibit Warning Fault Event
3481	Event	Start-Inhibit Warning Fault Event
3482	Shutdown	Start-Inhibit Shutdown Fault
3483	Shutdown	High Alternator Temperature 1 Shutdown Fault
3484	Shutdown	High Alternator Temperature 2 Shutdown Fault
3485	Shutdown	High Alternator Temperature 3 Shutdown Fault
3486	Shutdown	High Drive End Bearing Temperature Shutdown Fault
3487	Shutdown	High Non-Drive End Bearing Temp Shutdown Fault
3489	Warning	Compressor Bypass Actuator Error
3491	Shutdown	Oil Filter Restriction High
3497	Warning	Low AT1 Diesel Exhaust Fluid Tank Level
3498	Warning	AT1 DEF Tank Level Low
3499	Shutdown	Throttle Actuator 2- Special Instruction
3511	Shutdown	Throttle Actuator 2- Shorted High
3512	Shutdown	Throttle Actuator 2- Shorted Low
3513	Warning	Negative Sequence Overcurrent
3514	Shutdown	Throttle Actuator - Shorted Low
3515	Shutdown	Throttle Actuator - Special Instruction

Code	Lamp	Displayed Message
3521	Warning	Throttle Actuator - Temperature Low
3522	Warning	Throttle Actuator 2- Temperature Low
3539	Warning	Intake Throttle Sensor Circuit shorted to High
3541	Warning	Intake Throttle Sensor Circuit shorted to Low
3543	Warning	NOx limits exceeded - Cond Exists
3545	Warning	Aftertreatment 1 Outlet NOx Sensor - Abnormal
3547	Warning	Aftertreatment Diesel Exhaust Fluid Tank Empty
3555	Warning	Engine Wait to Start Lamp - Abnormal
3558	Warning	AT1 Diesel Exhaust Fluid Dosing Unit OOR High
3559	Warning	AT1 Diesel Exhaust Fluid Dosing Unit OOR Low
3562	Warning	AT DEF Line Heater Relay OOR High
3563	Warning	AT DEF Line Heater Relay OOR Low
3565	Warning	AT1 DEF Dosing Valve 1 OOR High
3567	Warning	AT DEF Dosing Valve Open Circuit
3568	Warning	AT DEF Dosing Valve Mechanical system Error
3571	Warning	AT1 Diesel Exhaust Fluid Pressure Sensor OOR High
3572	Warning	AT1 Diesel Exhaust Fluid Pressure Sensor OOR Low
3574	Warning	AT1 Diesel Exhaust Fluid Pressure Sensor Low
3575	Warning	AT1 Diesel Exhaust Fluid Pressure Sensor High
3577	Warning	AT Diesel Exhaust Fluid Return Valve OOR High
3578	Warning	AT Diesel Exhaust Fluid Return Valve OOR Low
3582	Warning	AT SCR Catalyst Conversion Efficiency Low
3583	Warning	AT1 Outlet NOx Sensor Heater - Abnormal
3584	Shutdown	Engine Derate: Special
3585	Warning	Generator Total Real Power: Root Cause Unkwn
3586	Warning	Generator Total Real Power: Data Incorrect
3587	Warning	Methane Percent Signal:Below Normal-Least Severe
3588	Shutdown	Methane Percent Signal:Below Normal-Most Severe
3589	Warning	Methane Percent Signal: Data Incorrect
3591	Shutdown	Methane Percent Signal: Special
3592	Warning	Methane Percent Signal: Current Above Normal
3593	Warning	Methane Percent Signal: Current Below Normal
3594	Warning	Eng Emissions Closed Loop Fueling Adj:Cond Exists
3595	Shutdown	Eng Emission Closed Loop Fuel Adj:Root Cause Unkwn

Code	Lamp	Displayed Message
3596	Warning	AT1 Diesel Exhaust Fluid Pressure Sensor Error
3599	Warning	Ground Current OOR Warning
3611	Warning	Custom Overcurrent Fault
3614	Warning	Coolant Level Sensor Received N/W Data in Error
3629	Warning	Device Calibration Update Recommended
3631	Shutdown	Device Calibration Update Required
3633	Warning	Engine Fan Clutch 2 Control Circuit OOR High
3634	Warning	Engine Fan Clutch 2 Control Circuit OOR Low
3641	Shutdown	Start Enable Line 1 Disabled
3642	Shutdown	Start Enable Line 2 Disabled
3643	Shutdown	Start Enable Line 3 is Disabled
3644	Shutdown	Intake Manifold Temperature: Special
3645	Shutdown	Intake Manifold 2 Temperature: Special
3646	Shutdown	Intake Manifold 3 Temperature: Special
3647	Shutdown	Intake Manifold 4 Temperature: Special
3649	Warning	AT1 Intake NOx Sensor Heater - Abnormal
3664	Shutdown	Genset Config Mismatch
3681	Warning	AT1 Outlet NOx Sensor Power Supply Error
3682	Warning	Aftertmt Intake Nox:Power Supply Data Incorrect
3694	Warning	Gain Adjust Potentiometer Circuit: OORL
3695	Warning	Frequency Adjust Potentiometer Circuit: OORL
3696	Warning	Droop Adjust Potentiometer Circuit: OORL
3697	Shutdown	RAM Refresh Error
3717	Warning	AT1 Outlet NOx Sensor - Out of Calibration
3718	Warning	Aftertreatment Intake Nox Sensor:Out of Cal
3724	Warning	Battery 1 Voltage: Below Normal
3725	Warning	Aftertreatment 1 Intake NOx Sensor - Abnormal
3727	None	Common Rail Fuel Press Relief Valve: Not Resp
3728	Shutdown	Engine Throttle Control Actuator: Network Error
3741	Warning	Common Rail Fuel Pressure: Above Normal
3748	Warning	AT1 Intake NOx Sensor - Data not Rational
3749	Warning	AT1 Outlet NOx Sensor - Data not Rational
3753	None	Diesel Particulate Filter Active Regen Inhibited
3846	Warning	Fuel Actuator Ctrl:Data Above Normal-least severe

Code	Lamp	Displayed Message
3847	Warning	Fuel Actuator Ctrl:Data Below Normal-Least Severe
3848	Shutdown	Fuel Actuator Control: Special
3849	Shutdown	Fuel Actuator Control: Bad Device
3851	Shutdown	Fuel Actuator Control: Network Error
3852	Warning	Fuel Act2Ctrl Valve:Data Above Normal-Least Severe
3853	Warning	Fuel Act2Ctrl Valve:Data Below Normal-Least Severe
3854	Shutdown	Fuel Actuator 2 Control Valve: Special
3855	Shutdown	Fuel Actuator 2 Control Valve: Bad Device
3856	Shutdown	Fuel Actuator 2 Control Valve: Network Error
3857	Warning	Fuel Actuator 2 Control Valve: Root Cause Unkwn
3858	Warning	Eng Turbochrg Compressor:Above Normal-Least Severe
3859	Warning	Eng Turbochrg Compressor:Below Normal-Least Severe
3861	Warning	Engine Turbocharger Compressor:Root Cause Unkwn
3862	Warning	Eng Turbocharg Compressor Bypass Actuator:Special
3863	Shutdown	Eng Turbochrg Compressor Bypass Actuator:Bad Comp
3864	Warning	Engine TurboChgr Comp Bypass Actuator: N/W error
3866	Warning	AT DEF Quality low Warning
3867	Warning	AT DEF Quality Low - Moderately Severe level
3868	Warning	AT Diesel Exhaust Fluid Quality Error
3869	Warning	LVRT Device Error
3871	Warning	LVRT Engine Governing Message Lost Error
3872	Warning	LVRT Count Warning Error
3873	Shutdown	LVRT Count Serious Error
3874	Warning	LVRT Stuck On Error
3875	Warning	LVRT Detection Error
3876	Warning	AT DEF Quality Sensor Mech system Error
3878	Warning	AT Diesel Exhaust Fluid Quality Sensor Data error
3917	Warning	Engine Turbocharger Lube Oil Pressure low Warning
3918	Warning	Engine Turbocharger Wastegate Actuator Cal Error
3931	Shutdown	Engine Protection System Approaching Shutdown
4135	Warning	Inducement Approaching: Performance is Active
4152	Warning	AT SCR Temperature Sensor Module - Abnormal
4155	Warning	AT1 DEF Dosing Unit Heater Relay OOR High
4156	Warning	AT1 DEF Dosing Unit Heater Relay OOR Low

Code	Lamp	Displayed Message
4157	Warning	AT DEF Return Valve Mechanical system Error
4159	Warning	AT SCR Temperature Sensor Module - Bad Device
4164	Warning	AT SCR Temperature Sensor Module OOR High
4165	Warning	AT SCR Temperature Sensor Module OOR Low
4166	Warning	AT SCR Temperature Sensor Module High
4168	Warning	AT1 DEF Dosing Unit Heater OOR High
4169	Warning	AT1 DEF Dosing Unit Heater OOR Low
4171	Warning	Selective Catalytic Reduction Temperature Low
4241	Warning	AT DEF Quality - Received Network Data Error
4243	Warning	AT1 Diesel Exhaust Fluid Temperature 2 - Abnormal
4249	Warning	AT1 DEF Dosing Temperature - Abnormal
4252	None	Engine Wait to Start Lamp - Condition Exists
4261	Warning	AT SCR Temp Sensor Module - Root Cause Unknown
4262	Warning	HPCR Fuel Pressure Relief Valve OOR High
4263	Warning	HPCR Fuel Pressure Relief Valve OOR Low
4265	Warning	High Press Common Rail Fuel Press Relief Valve Err
4277	Warning	AT Diesel Exhaust Fluid Quality - Abnormal
4285	Shutdown	LVRT Shutdown Fault
4293	Warning	Engine Brake Active Lamp OOR High
4294	Warning	Engine Brake Active Lamp OOR Low
4358	Shutdown	Setup Mode Shutdown
4437	None	J1939 Network 4 Data Incorrect
4517	Warning	Vehicle Identification Number - Out of Calibration
4572	Warning	AT1 DEF Tank Temperature - Abnormal
4585	Shutdown	AT1 SCR Catalyst System - Special Instructions
4615	Shutdown	Fuel Delivery Pressure Above Normal
4636	Warning	Throttle Delta Pressure Incorrect
4642	Shutdown	Water In Fuel Above Normal
4643	Warning	Inj Solenoid Driver 7 Calib Error
4644	Warning	Injector Solenoid Driver 8 Calib Error
4645	Warning	Injector Solenoid Driver 9 Calib Error
4646	Warning	Injector Solenoid Driver 10 Calib Error
4647	Warning	Injector Solenoid Driver 11 Calib Error
4648	Warning	Injector Solenoid Driver 12 Calib Error

Code	Lamp	Displayed Message
4649	Warning	Injector Solenoid Driver 13 Calib Error
4651	Warning	Injector Solenoid Driver 14 Calib Error
4652	Warning	Injector Solenoid Driver 15 Calib Error
4653	Warning	Injector Solenoid Driver 16 Calib Error
4658	Warning	AT SCR Actual Dosing Reagent Quantity Low
4677	Warning	AT1 DEF Tank Level Abnormal Update Rate
4686	Warning	Connector Cap Not Present
4688	Warning	Water in Fuel Indicator 2 Sensor OOR Hi
4689	Warning	Water in Fuel Indicator 2 Sensor OOR Lo
4696	Warning	Crankcase Pressure 2 OOR High
4697	Warning	Crankcase Pressure 2 OORL
4698	None	Crankcase Pressure 2 Above Normal
4699	Warning	Crankcase Pressure 2 Moderate Hi
4711	None	Crankcase Pressure 2 Below Normal
4731	Warning	AT1 DEF Tank Temp Sensor Out of Calibration
4732	Warning	AT1 DEF Tank Level Sensor Out of Calibration
4739	Warning	AT1 DEF Tank Level Sensor - Root Cause Unknown
4741	Warning	AT DEF Quality Sensor Open Circuit
4742	Warning	AT DEF Quality Sensor Short Circuit
4743	Warning	AT1 DEF Temperature 2 Sensor Open Circuit
4744	Warning	AT1 DEF Temperature 2 Sensor Short Circuit
4745	Warning	AT1 DEF Temperature 2 - Root Cause Unknown
4747	Warning	AT Intake Oxygen Sensor Data not Rational - High
4748	Warning	AT Intake Oxygen Sensor Data not Rational - Low
4749	Warning	AT Outlet Oxygen Sensor Data not Rational - High
4751	Warning	AT Outlet Oxygen Sensor Data not Rational - Low
4761	Shutdown	Genset Voltage Sensing MCB Protection
4766	Warning	Customer Gas Valve Close Warning
4767	Shutdown	Customer Gas Valve Close Shutdown
4768	Warning	AT1 DEF Property - Root Cause Unknown
4769	Warning	AT1 DEF Tank Level Sensor Abnormal Rate Change
4789	Warning	Fan Speed High - Most Severe Level
4791	Warning	Fan Speed Low - Most Severe Level
4842	None	Aftertreatment Diesel Exhaust Fluid Quality High

Code	Lamp	Displayed Message
4867	Warning	HPCR Fuel Pressure Relief Valve - Condition Exists
4872	Warning	System Network Failure
4873	Warning	Genset Failed to Come Online
4874	Warning	Load Demand Version Incompatibility
4875	Event	Genset Ineligible For Load Demand
4876	Warning	Genset Lost On System Network
4877	Warning	System Settings Not Synchronized
4878	Warning	Check System Network Installation
4879	Warning	Load Demand Setup Error
4881	Warning	System Genset ID Conflict
4882	Warning	Genset Bus Overload
4883	Warning	Prelube Cycle Failed
4884	Warning	Prelube Pump Stuck ON
4885	Shutdown	Fuel Supply Pump Not Responding
4886	Warning	Fuel Pump Voltage Moderate Low
4887	Shutdown	Fuel Supply Voltage Below Normal
4888	Shutdown	Fuel Supply Temperature: Moderate High
4889	Shutdown	Fuel Supply Temperature Critical High
4891	Warning	Fuel Supply Pump Root Unknown Cause
4893	Warning	Fuel Filter Press Moderate High
4894	Warning	Fuel Supply Pump Calib Error
4927	Warning	Fuel Valve 1 Bad Device
4928	Warning	Fuel Valve 1 Power Supply Data Incorrect
4929	Warning	Fuel Valve 1 Power Supply OOR High
4931	Warning	Fuel Valve 1 Power Supply OOR Low
4932	Event	Fuel Valve 1 Temp Above Normal
4933	Event	Fuel Valve 1 Position Data Error
4934	Warning	Fuel Valve 1 Voltage OOR High
4935	Warning	Fuel Valve 1 Voltage OOR Low
4936	Warning	Fuel Valve 1 Unknown Cause
4937	Warning	Fuel Valve 1 Calib Error
4941	Warning	Starter Control Voltage OOR High
4942	Warning	Starter Control Voltage OOR Low
4943	Warning	Failed To Crank Condition Exists

Code	Lamp	Displayed Message
4944	Warning	Failed To Start Condition Exists
4945	Warning	Uncommanded Crank Cond Exists
4946	Event	Engine Crank Without Prelube Condition Exists
4958	Warning	Fuel Valve 1 Data Incorrect
4959	Event	Fuel Valve 1 Condition Exists
4961	Event	Fuel Valve 1 Update Rate Error
4982	Warning	Fuel Supply Pump Update Rate Error
5119	Warning	Fuel Pump Oil Pressure Sensor OOR High
5121	Warning	Fuel Pump Oil Pressure Sensor OOR Low
5122	Warning	Fuel Pump Oil Pressure Sensor Data Incorrect
5123	Warning	Injector Solenoid 19 Low Current
5124	Warning	Injector Solenoid 20 Low Current
5135	Shutdown	Genset Overload
5145	Warning	Load Demand Genset Bus Failure
5148	Warning	Allow Start Override Active Condition Exists
5149	Warning	Prelube Cycle failed during Non-Emergency Start
5151	Warning	Intake air restriction indicator 1 active
5152	Warning	Intake air restriction indicator 2 active
5153	Warning	Intake air restriction indicator 3 active
5154	Warning	Intake air restriction indicator 4 active
5155	Warning	Low Battery 1 Voltage
5156	Warning	Low Battery 2 Voltage
5157	Warning	Low Battery 3 Voltage
5158	Warning	Low Battery 4 Voltage
5159	Warning	Weak Battery 1
5161	Warning	Weak Battery 2
5162	Warning	Weak Battery 3
5163	Warning	Weak Battery 4
5164	Warning	Battery Charger 2 Failed Fault
5165	Warning	Battery Charger 3 Failed Fault
5166	Warning	Battery Charger 4 Failed Fault
5176	Warning	AT1 DEF Tank Level2 Abnormal Update Rate
5178	Warning	Crankcase Pressure 2 Data Incorrect
5182	Warning	AUX101 0 Input 1 Fault

Code	Lamp	Displayed Message
5247	Warning	AT1 SCR Intake Temp. High Warning
5283	Warning	High Battery 1 Voltage
5284	Warning	High Battery 2 Voltage
5285	Warning	High Battery 3 Voltage
5286	Warning	High Battery 4 Voltage
5287	Warning	Starter Air Supply Pressure Low
5288	Warning	Starter Air Tank Volume Low
5377	Warning	AUX101-3 Communication Lost Fault
5378	Warning	AUX101-4 Communication Lost Fault
5397	Shutdown	L-N Short Circuit Shutdown
5398	Shutdown	L-L Short Circuit Shutdown
5399	Event	AmpSentry Maintenance Mode Active
5531	Shutdown	Cam Position Frequency Mismatch
5655	Warning	AT1 SCR Conversion Efficiency
5689	Warning	AT1 Outlet NOx Sensor Error
5838	Warning	AT1 Outlet NOx Sensor Abnormal Rate of Change
5864	Warning	AT1 DEF Pump Command OOR High
5865	Warning	AT1 DEF Pump Command OOR Low
5866	Warning	AT DEF Dosing Unit Relay Feedback OOR High
5867	Warning	AT DEF Dosing Unit Relay Feedback OOR Low
5887	None	AT1 SCR System Hydrocarbon High
5888	Warning	AT1 SCR System Hydrocarbon High Warning
5889	Shutdown	AT1 SCR System Hydrocarbon High Shutdown
5935	Warning	AT1 DEF Pressure Mechanical System Error
5936	Warning	AT1 DEF Pressure High Warning
6256	None	Battery 1 Voltage High
6257	None	Battery 1 Voltage Low
6258	None	Electric Lift Pump for Eng Fuel Supply OOR High
6259	None	Electric Lift Pump for Eng Fuel Supply OOR Low
6263	None	Fan Control Circuit OOR High
6264	None	Fan Control Circuit OOR Low
6336	None	Crankcase Breather Filter Heater OOR High
6337	None	Crankcase Breather Filter Heater OOR Low
6464	None	AT1 Out Nox Sens Error

Code	Lamp	Displayed Message
6467	None	Fan Speed High
6468	None	Fan Speed Low
6475	None	AT1 DEF Tank Heater Mechanical Error
6476	None	AT1 DEF Tank Heater Low
6477	None	AT1 DEF Line Heater Relay OOR High
6478	None	AT1 DEF Line Heater Relay OOR Low
6479	None	AT1 DEF Tank Heater OOR High
6481	None	AT1 DEF Tank Heater OOR Low
6522	None	Coolant Level Sensor 1 OOR Low
6523	None	Coolant Level Sensor 1 OOR High
6524	None	Engine Oil Temperature Sensor 1 OOR High
6525	None	Engine Oil Temperature Sensor 1 OOR Low
6526	None	AT1 DEF Tank Level Out of Calibration Error
6531	None	AT1 DEF Line Heater1 OOR High
6532	None	AT1 DEF Line Heater1 OOR Low
6533	None	AT1 DEF Line Heater2 OOR High
6534	None	AT1 DEF Line Heater2 OOR Low
6535	None	AT1 DEF Line Heater3 OOR High
6536	None	AT1 DEF Line Heater3 OOR Low
6595	None	Engine Speed Root Cause Unknown
6619	None	AT1 DEF Temperature 2 Abnormal Update Rate
6692	None	AT1 SCR System Soot High
6693	Warning	AT1 SCR System Soot High Warning
6694	Shutdown	AT1 SCR System Soot High Shutdown
6752	None	AT DEF Quality Low
7135	Warning	Engine Turbocharger Speed High Warning
7243	Warning	Failed Normal Start Attempt
7268	None	AT1 SCR System Cleaning Incomplete Error
7269	Warning	AT1 SCR System Cleaning Incomplete Error Warning
7697	Shutdown	Bank Cut-Off FSO Failure
7823	Warning	Cylinder Cut-Off System failure
7824	Warning	Cylinder Cut-Off System State and Feedback Mismatch
7825	Shutdown	Generator Total Real Power Sensing Failure
8632	Warning	Charging Alternator Fuse Failure

Code	Lamp	Displayed Message
9945	Warning	Injector 6 Circuit 2 Error
9946	Warning	Injector 5 Circuit 2 Error
9947	Warning	Injector 4 Circuit 2 Error
9948	Warning	Injector 3 Circuit 2 Error
9949	Warning	Injector 2 Circuit 2 Error
9951	Warning	Injector 1 Circuit 2 Error
9971	Event	ECM Derate Fault
9973	Event	Watchdog Reset Occurrence
13266	Warning	Engine Crankcase Pressure 2: Data Valid: Below Normal: Mod Severe

8.5.4 Troubleshooting Procedures for Fault Codes

TABLE 32. TROUBLESHOOTING PROCEDURES FOR FAULT CODES

Fault Code	Corrective Action – (if in doubt, call your authorized service technician)
CODE: 143 LAMP: Warning MESSAGE: Low Oil Rifle Pressure	Indicates engine oil pressure has dropped below the warning trip point. If the generator set is powering critical loads and cannot be shut down, wait until the next shutdown period and then follow the fault code 415 procedure.
CODE: 144 LAMP: Warning MESSAGE: High Coolant 1 Temp	
CODE: 145 LAMP: Warning MESSAGE: Low Coolant 1 Temp	
CODE: 146 LAMP: Derate MESSAGE: Pre-High Engine Coolant Temperature	Indicates the engine is operating near cooling system capacity. Increase in load or higher ambient temperature may cause a High Coolant Temp (151) shutdown. Review fault code 151 correction list for other possible causes.

Fault Code	Corrective Action – (if in doubt, call your authorized service technician)
CODE: 151	Indicates the engine has overheated (coolant temperature has risen above the shutdown trip point or coolant level is low). Allow the engine to cool down completely before proceeding with the following checks: <ol style="list-style-type: none"> 1. Look for possible coolant leakage points and repair if necessary. Check the coolant level and replenish if low. 2. Check for obstructions to cooling airflow and correct as necessary. 3. Check the fan belt and repair or tighten if necessary. 4. Check the blower fan and circulation pumps on remote radiator installations. 5. Reset the control and restart after locating and correcting the problem.
LAMP: Shutdown	
MESSAGE: High Coolant Temp	
CODE: 155	Indicates the engine has overheated (intake manifold temperature has risen above the shutdown trip point). Large load or high ambient temperature may be the cause. Review fault code 151 correction list for other possible causes.
LAMP: Shutdown	
MESSAGE: High Intake Manf 1 Temp	
CODE: 196	Indicates engine coolant level has fallen below the trip point. If the generator is powering critical loads and cannot be shut down, wait until the next shutdown period. If the engine can be stopped, allow the engine to cool down completely before proceeding: <ol style="list-style-type: none"> 1. Look for possible coolant leakage points and repair if necessary. 2. Check coolant level and replenish if low. 3. Reset the control and restart after locating and correcting the problem.
LAMP: Warning	
MESSAGE: Low Coolant 1 Level	
CODE: 197	Indicates the engine coolant level has fallen below the trip point. If the generator is powering critical loads and cannot be shut down, wait until the next shutdown period. If the engine can be stopped, allow the engine to cool down completely before proceeding: <ol style="list-style-type: none"> 1. Look for possible coolant leakage points and repair if necessary. 2. Check coolant level and replenish if low. 3. Reset the control and restart after locating and correcting the problem.
LAMP: Warning	
MESSAGE: Low Coolant Level	
CODE: 235	Low Coolant Level input is active and the threshold response is set to Shutdown. Allow the engine to cool down completely before proceeding: <ol style="list-style-type: none"> 1. Look for possible coolant leakage points and repair if necessary. 2. Check the coolant level and replenish if low. 3. Reset the control and restart after locating and correcting the problem.
LAMP: Shutdown	
MESSAGE: Low Coolant Level	
CODE: 359	Indicates a possible fault with the control or starting system (engine cranks but fails to start). Allow the engine to cool down completely before proceeding with the following checks: <ol style="list-style-type: none"> 1. Check for an empty fuel tank, fuel leaks, or blocked fuel lines and correct as required. 2. Check for a dirty fuel filter and replace if necessary. 3. Check for a dirty or blocked air filter and replace if necessary. 4. Clean and tighten all battery cable connections. 5. Discharged or defective battery. Recharge or replace. 6. Reset the control and restart after correcting the problem.
LAMP: Shutdown	
MESSAGE: Fail To Start	
CODE: 415	Indicates the engine oil pressure has dropped below the shutdown trip point. Allow the engine to cool down completely before proceeding with the following checks: <ol style="list-style-type: none"> 1. Check the oil level, lines and filters. 2. If the oil system is ok but the oil level is low, replenish. 3. Reset the control and restart after locating and correcting the problem.
LAMP: Shutdown	
MESSAGE: Low Oil Rifle press	

Fault Code	Corrective Action – (if in doubt, call your authorized service technician)
CODE: 427	Communication between the engine control (ECM) and the PCC is severed. Allow the engine to cool down completely before proceeding: 1. Ensure the E-Stop button is not active. Reset the Local/Remote Emergency Stop.
LAMP: Warning	
MESSAGE: CAN Data Link Degraded	
CODE: 441	Indicates battery voltage is below 24 VDC and is approaching a low level at which unpredictable operation will occur. If the engine can be stopped, allow the engine to cool down completely before proceeding: 1. Clean battery terminals and tighten all connections. 2. Check the electrolyte level, top up and re-charge (if applicable). 3. Discharged or defective battery. Recharge or replace.
LAMP: Warning	
MESSAGE: Low Battery 1 Voltage	
CODE: 442	Indicates the battery voltage to the control is approaching a high level (exceeding 32 VDC) at which damage to the control can occur. If the engine can be stopped, allow the engine to cool down completely before proceeding: 1. Clean the battery terminals and tighten all connections. 2. Check the battery charge float level if applicable (lower float level).
LAMP: Warning	
MESSAGE: High Battery 1 Voltage	
CODE: 488	Indicates the engine has overheated (intake manifold temperature has risen above the shutdown trip point). Large load or high ambient temperature may be the cause. Review fault code 151 correction list for other possible causes.
LAMP: Derate	
MESSAGE: High Intake Manf 1 temp	
CODE: 611	Indicates that an engine hot shutdown has occurred (cooldown timers were bypassed). This condition will occur when the operator presses the Emergency Switch or presses the Stop button before the generator set completes the cooldown operation. (Generator set should run at 10% or less load for three minutes before engine shutdown). This type of hot shutdown should be avoided; it can cause possible loss of performance and engine damage.
LAMP: Warning	
MESSAGE: Engine Hot Shut Down	
CODE: 781	Communication between the engine control (ECM) and the PowerCommand® 3.3 control has been severed. 1. Ensure the E-Stop button is not active. Reset the Local/Remote Emergency Stop.
LAMP: Shutdown	
MESSAGE: CAN Data Link Failure	
CODE: 1131	Indicates that the control is in Battle Short mode (used to bypass several fault shutdowns therefore allowing generator set operation during emergencies). 1. If possible, investigate any fault codes that are being bypassed.
LAMP: Warning	
MESSAGE: Battle Short Active	
CODE: 1312, 1317, and 1318	The nature of the fault is an optional customer selection – configurable input #. Example inputs: Low Fuel Day Tank, Water In Fuel, Ground Fault, etc. Each of the fault functions can be programmed using InPower service tool or by accessing the Setup menu. If the engine can be stopped, allow the engine to cool down completely before proceeding: 1. Check the Input # requirements and correct if possible.
LAMP: Event	
MESSAGE: Configurable Input #2, 13, and 14	

Fault Code	Corrective Action – (if in doubt, call your authorized service technician)
CODE: 1416	Records (in the Fault History log) a bypassed shutdown fault while the generator set was in Battle Short mode (this is used to bypass several critical fault shutdowns therefore allowing generator set operation during emergencies).
LAMP: Warning	
MESSAGE: Fail To Shutdown	
CODE: 1433/1434	Indicates a local or remote Emergency Stop has been activated. Emergency Stop shutdown status can be reset only at the local control panel. Allow the engine to cool down completely before proceeding with the following checks:
LAMP: Shutdown	
MESSAGE: Local Emergency Stop/Remote Emergency Stop	
CODE: 1435	Indicates the engine coolant heater is not operating or is not circulating coolant. If the engine can be stopped, allow the engine to cool down completely before proceeding with the following checks:
LAMP: Warning	
MESSAGE: Low Coolant Temperature	
CODE: 1438	Indicates a possible fault with the control, speed sensing, or starting system. Allow the engine to cool down completely before proceeding with the following checks:
LAMP: Shutdown	
MESSAGE: Fail To Crank	
CODE: 1439	Indicates the day tank fuel supply is running low. If the engine can be stopped, allow engine to cool down completely before proceeding with the following checks:
LAMP: Warning	
MESSAGE: Low Day Tank Fuel Switch	
CODE: 1441	Indicates the fuel level has gone below the threshold setting for the low fuel level against the time setting. If the engine can be stopped, allow the engine to cool down completely before proceeding with the following checks:
LAMP: Warning	
MESSAGE: Low Fuel Level	

Fault Code	Corrective Action – (if in doubt, call your authorized service technician)
CODE: 1442	Indicates that, during cranking, the battery voltage is at or below the weak battery warning trip point for a time greater than or equal to the weak battery set time. If the engine can be stopped, allow the engine to cool down completely before proceeding with the following checks: 1. See code 441.
LAMP: Warning	
MESSAGE: Weak Battery	
CODE: 1443	During cranking, the battery voltage has dropped below the operating voltage of the PowerCommand® 3.3 control, which resets the PowerCommand® 3.3 control. After three consecutive resets, event/fault code 1443 becomes active. If the engine can be stopped, allow the engine to cool down completely before proceeding with the following checks: 1. See code 441.
LAMP: Shutdown	
MESSAGE: Dead Battery	
CODE: 1448	Indicates that the generator set frequency has dropped below 90% of nominal for approximately ten seconds. Allow the engine to cool down completely before proceeding with the following checks: 1. Check the fuel supply. 2. Check the air intake supply. 3. Check the load and correct any overload.
LAMP: Shutdown	
MESSAGE: Under Frequency	
CODE: 1449	Indicates that the generator set frequency has exceeded the Over Frequency threshold for the set time parameter. Allow the engine to cool down completely before proceeding with the following checks: 1. Check the fuel supply. 2. Check the air intake supply. 3. Check the load and correct any overload.
LAMP: Shutdown	
MESSAGE: Over Frequency	
CODE: 1852	Indicates that the water in the fuel is above normal and has reached the warning trip point. If the engine can be stopped, allow the engine to cool down completely before proceeding with the following checks: 1. Check fuel in tank (local or remote). 2. Drain and refill if necessary. Be aware of all Health and Safety, and environmental issues if draining tank.
LAMP: Warning	
MESSAGE: Pre-High H2O In Fuel	
CODE: 2977	Indicates the engine coolant level, in the second radiator, has fallen below the trip point. If the generator is powering critical loads and cannot be shut down, wait until the next shutdown period. If the engine can be stopped, allow the engine to cool down completely before proceeding: 1. Look for possible coolant leakage points and repair if necessary. Check coolant level and replenish if low. 2. Reset the control and restart after locating and correcting the problem.
LAMP: Warning	
MESSAGE: Low Coolant 2 Level	
CODE: 3416	Refer to fault codes 359 and 1438
LAMP: Warning	
MESSAGE: Start System Fault – Condition Exists	

8.6 Line Circuit Breaker

If the load exceeds the circuit breaker current rating, the line circuit breaker will open, preventing the generator set from being overloaded. If the circuit breaker trips, locate the source of the overload or short circuit, and correct/eliminate the fault. Manually reset the breaker. Clear any fault messages and when safe to do so, reconnect the load to the generator.

9 Manufacturing Facilities

U.S. and CANADA	EMEA, CIS	BRAZIL
Cummins Inc. 1400 73rd Ave. NE Minneapolis, MN 55432 USA	Cummins Inc. Royal Oak Way South Daventry Northamptonshire NN11 8NU United Kingdom	Rua Jati, 310, Cumbica Guarulhos, SP 07180-900 CNPJ: 43.2201.151/0001-10 Brazil
Toll Free 1-800-CUMMINS™ (1-800-286-6467) Fax +1 763-574-5298	Phone +44 1327 88-6453 Fax +44 1327 88-6125	Phone 0800 286 6467
CHINA	INDIA	ASIA PACIFIC
Cummins Inc. No.118 South Quanli Road , Wuhan Economic& Technological Development Zone , Hubei, P.R.China 430058	Cummins Inc. Plot No B-2, SEZ Industrial Area, Village-Nandal & Surwadi, Taluka- Phaltan Dist- Satara, Maharashtra 415523 India	Cummins Sales and Service Singapore Pte Ltd 85 Tuas South Avenue 1 Singapore 637419
Phone + 86 (27) 8421 4008 Fax + 86 (27) 8421 4804	Phone +91 021 66305514	Fax +65 6265 6909
LATIN AMERICA	MEXICO	
3350 Southwest 148th Ave. Suite 205 Miramar, FL 33027 USA	Eje 122 No. 200 Zona Industrial San Luis Potosi, S.L.P. 78395 Mexico Eje 120 No. 201 Zona Industrial San Luis Potosi, S.L.P. 78395 Mexico	
Phone +1 954 431 551 Fax +1 954 433 5797	Phone +52 444 870 6700 Fax +52 444 824 0082	

This page is intentionally blank.

power.cummins.com

Copyright © 2025 Cummins Inc. All rights reserved.

Cummins, the "C" logo, PowerCommand, AmpSentry, and InPower are trademarks of Cummins Inc.

Other company, product, or service names may be trademarks or service marks of others.

Specifications are subject to change without notice.

