

Cat® D400 GC DIESEL GENERATOR SETS



Standby: 60 Hz, 480V & 600V



Image shown might not reflect actual configuration

Engine Model	Cat® C13 In-line6, 4-cycle diesel
Bore x Stroke	130mm x 157mm (5.1in x 6.2in)
Displacement	12.5 L (763 in ³)
Compression Ratio	16.3:1
Aspiration	Turbocharged Air-to-Air Aftercooled
Fuel Injection System	MEUI
Governor	Electronic ADEM™ A4

Standby	Performance Strategy
400 ekW, 500 kVA	EPA Certified for Stationary Emergency Application

PACKAGE PERFORMANCE

Performance	Standby	
Frequency	60 Hz	
Genset Power Rating	500 kVA	
Gen set power rating with fan @ 0.8 power factor	400 ekW	
Emissions	EPA TIER 3	
Performance Number	EM1694	
Fuel Consumption		
100% load with fan	105.8 L/hr	27.9 gal/hr
75% load with fan	90.7 L/hr	24.0 gal/hr
50% load with fan	66.2 L/hr	17.5 gal/hr
25% load with fan	37.7 l/hr	10.0 gal/hr
Cooling System¹		
Radiator air flow restriction (system)	0.12 kPa	0.48 in. Water
Radiator air flow	497 m ³ /min	17551 cfm
Engine coolant capacity	14.2 L	3.8 gal
Radiator coolant capacity	30 L	8 gal
Total coolant capacity	34 L	12 gal
Inlet Air		
Combustion air inlet flow rate	24.4 m ³ /min	966.6 cfm
Max. Allowable Combustion Air Inlet Temp	47 °C	116 °F
Exhaust System		
Exhaust stack gas temperature	567.4 °C	1053.4 °F
Exhaust gas flow rate	82.0 m ³ /min	2894.9 cfm
Exhaust system backpressure (maximum allowable)	10.0 kPa	40.0 in. water
Heat Rejection		
Heat rejection to jacket water	156 kW	8857 Btu/min
Heat rejection to exhaust (total)	398 kW	22607 Btu/min
Heat rejection to aftercooler	71 kW	4023 Btu/min
Heat rejection to atmosphere from engine	52 kW	2945 Btu/min
Heat rejection from alternator	29 kW	1661 Btu/min

Emissions (Nominal) ²	Standby	
NOx	2274.7 mg/Nm ³	4.58 g/hp-hr
CO	666.9 mg/Nm ³	1.35 g/hp-hr
HC	6.2 mg/Nm ³	0.01 g/hp-hr
PM	39.4 mg/Nm ³	0.10 g/hp-hr
Alternator ³		
Voltages	480V	600V
Motor Starting Capability @ 30% Voltage Dip	871	731
Current	601.4	481.1
Frame Size	M3134L4	M3115L4
Excitation	S.E	AREP
Temperature Rise	105°C	130°C

WEIGHTS & DIMENSIONS – OPEN SET

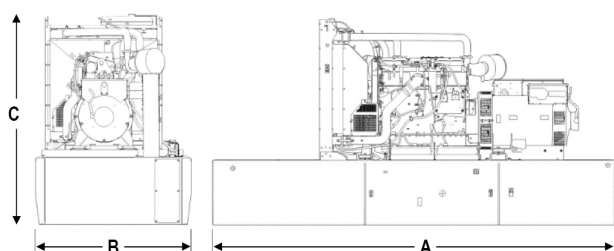

Base	Dim "A" mm (in)	Dim "B" mm (in)	Dim "C" mm (in)	Generator Set Weight kg (lb)
Skid (Wide Base)	4625 (182.8)	1630 (64.2)	2039 (80.3)	3325 (7330.4)
Integral Tank Base	4625 (182.8)	1630 (64.2)	2456 (96.7)	4107 (9054.4)

FUEL TANK CAPACITY

Tank Design	Total Capacity		Useable Capacity	
	Litre	Gallon	Litre	Gallon
Integral	2820	744.9	2553	674.4

DEFINITIONS AND CONDITIONS

¹ For ambient and altitude capabilities consult your Cat dealer. Air flow restriction (system) is added to existing restriction from factory.

² Emissions data measurement procedures are consistent with those described in EPA CFR 40 Part 89, Subpart D & E and ISO8178-1 for measuring HC, CO, PM, NOx. Data shown is based on steady state operating conditions of 77° F, 28.42 in HG and number 2 diesel fuel with 35° API and LHV of 18,390 BTU/lb. The nominal emissions data shown is subject to instrumentation, measurement, facility and engine to engine variations. Emissions data is based on 100% load and thus cannot be used to compare to EPA regulations which use values based on a weighted cycle.

³ UL 2200 Listed packages may have oversized generators with a different temperature rise and motor starting characteristics. Generator temperature rise is based on a 40° C ambient per NEMA MG1-32.

APPLICABLE CODES AND STANDARDS:

AS1359, CSA C22.2 No100-04, UL142, UL489, UL869, UL2200, NFPA37, NFPA70, NFPA99, NFPA110, IBC, IEC60034-1, ISO3046, ISO8528, NEMA MG1-22, NEMA MG1-33, 2006/95/EC, 2006/42/EC, 2004/108/EC.

Note: Codes may not be available in all model configurations. Please consult your local Cat Dealer representative for availability.

STANDBY: Output available with varying load for the duration of the interruption of the normal source power. Average power output is 70% of the standby power rating. Typical operation is 200 hours per year, with maximum expected usage of 500 hours per year.

RATINGS: Ratings are based on SAE J1349 standard conditions. These ratings also apply at ISO3046 standard conditions.

Fuel Rates are based on fuel oil of 35° API [16° C (60° F)] gravity having an LHV of 42 780 kJ/kg (18,390 Btu/lb) when used at 29° C (85° F) and weighing 838.9 g/litre (7.001 lbs/U.S. gal.). Additional ratings may be available for specific customer requirements, contact your Caterpillar representative for details. For information regarding Low Sulfur fuel and Biodiesel capability, please consult your Cat dealer.

LEHE2009-05 (05-20)

www.Cat.com/electricpower

© 2020 Caterpillar. All rights reserved. Materials and specifications are subject to change without notice. The International System of Units (SI) is used in this publication. CAT, CATERPILLAR, their respective logos, "Caterpillar Corporate Yellow", the "Power Edge" and Cat "Modem Hex" trade dress as well as corporate and product identity used here in, are trademarks of Caterpillar and may not be used without permission.



Image shown might not reflect actual configuration

GCCP 1.2 - Control Panel

GCCP 1.2 is an auto Start Control Module suitable for a wide variety of diesel gen-set applications. Monitoring an extensive number of engine parameters, the modules will display warnings, shutdown and engine status information on the backlit LCD screen, illuminated LEDs and remote PC.

FEATURES

- 4-line back-lit LCD text display
- Multiple display languages
- Five-key menu navigation
- LCD alarm indication
- Customisable power-up text and images
- Data logging facility
- Internal PLC editor
- Protections disable feature
- Fully configurable via PC using USB & RS485 communication
- Front panel configuration with PIN protection
- Power save mode
- 3-phase generator sensing and protection
- Generator current and power monitoring (kW, kvar, kVA, pf)
- kW and kvar overload and reverse power alarms
- Over current protection
- Unbalanced load protection
- Breaker control via fascia buttons
- Fuel and start outputs configurable when using CAN Support for 0 V to 10 V & 4 mA to 20 mA sensors
- 8 configurable digital inputs (3 available for Customer use)
- 8 configurable digital outputs (5 available for Customer use)
- 4 configurable analogue inputs (3 available for Customer Use)
- CAN, MPU and alternator frequency speed sensing in one variant
- Real time clock
- Engine pre-heat and post-heat functions
- Engine run-time scheduler
- Engine idle control for starting & stopping
- Fuel usage monitor and low fuel level alarms
- 3 configurable maintenance alarms

BENEFITS

- Hours counter provides accurate information for monitoring and maintenance periods
- User-friendly set-up and button layout for ease of use
- Multiple parameters are monitored & displayed simultaneously for full visibility
- The module can be configured to suit a wide range of applications for user flexibility
- PLC editor allows user configurable functions to meet user specific application requirements.
- RS485 Communication port can be used for the Remote Monitoring Communication (Compatible with Cat PLG)

SPECIFICATION

DC SUPPLY

CONTINUOUS VOLTAGE RATING

8 V to 35 V Continuous
5 V for upto 1 minute

CRANKING DROPOUTS

Able to survive 0 V for 100 ms, providing supply was at least 10 V before dropout and supply recovers to 5 V. This is achieved without the need for internal batteries.

LEDs and backlight will not be maintained during cranking.

MAXIMUM OPERATING CURRENT

260 mA at 12 V, 150 mA at 24 V

MAXIMUM STANDBY CURRENT

145 mA at 12 V, 85 mA at 24 V

CHARGE FAIL/EXCITATION RANGE

0 V to 35 V

GENERATOR & MAINS (UTILITY) VOLTAGE RANGE

15 V to 415 V AC (Ph to N)
26 V to 719 V AC (Ph to Ph)

FREQUENCY RANGE

3.5 Hz to 75 Hz

MAGNETIC PICKUP VOLTAGE RANGE

+/- 0.5 V to 70 V

FREQUENCY RANGE

10,000 Hz (max)

INPUTS

DIGITAL INPUTS A TO H

Negative switching

ANALOGUE INPUTS A & D

Configurable as:

Negative switching digital input 0 V to 10 V sensor
4 mA to 20 mA sensor Resistive sensor

ANALOGUE INPUTS B & C

Configurable as:

Negative switching digital input Resistive sensor

OUTPUTS

OUTPUT A & B (FUEL & START)

15 A DC at supply voltage

AUXILIARY OUTPUTS C, D, E, F, G & H

2 A DC at supply voltage

DIMENSIONS OVERALL

216 mm x 158 mm x 43 mm
8.5" x 6.2" x 1.5"

PANEL CUT-OUT

184 mm x 137 mm
7.2" x 5.3"

MAXIMUM PANEL THICKNESS

8 mm
0.3"

STORAGE TEMPERATURE RANGE

-40°C to +85°C
-40 °F to +185 °F

OPERATING TEMPERATURE RANGE

-30°C to +70°C
-22 °F to +158 °F

LEHE2017-02 (09-20)

www.Cat.com/electricpower

©2020 Caterpillar All rights reserved. Materials and specifications are subject to change without notice. The International System of Units (SI) is used in this publication. CAT, CATERPILLAR, their respective logos, "Caterpillar Corporate Yellow", the "Power Edge" and Cat "Modern Hex" trade dress as well as corporate and product identity used herein, are trademarks of Caterpillar and may not be used without permission.

100 Amp Load Center



Image shown may not reflect actual package.

100 Amp Load Center

Specifications	
Number of Spaces	6
System Voltage	120 / 240VAC
Number of Tandem Circuit Breakers	6
Phase	1 Ph
NEMA Degree of Protection	NEMA 3R Outdoor
Electrical Connection	Lugs
Wiring Configuration	3-Wire
Material	Tin Plated Aluminum Busbar
Enclosure Material	Welded Galvanized Steel
Cover Finish	Gray Baked Enamel
Product Certifications	UL E-6294
Gauge	AWG 8...AWG 1 (Aluminium / Copper)

Dimensions and Specifications	
Height / Width / Depth	321 mm / 226 mm / 127 mm
GFCI	16A (120V)
Battery Charger	6A (120V)
Jacket Water Heater	11.25A (240V)
Alternator Heater	1.04A (240V)
Total Load	34.29A Max

L1	
GFCI	16A (120V)
Jacket Water Heater	11.25A (240V)
Alternator Heater	1.04A (240V)
Total Load	28.29A Max

L2	
Battery Charger	6A (120V)
Jacket Water Heater	11.25A (240V)
Alternator Heater	1.04A (240V)
Total Load	18.29A Max

www.cat.com/electricpower

©2020 Caterpillar
All rights reserved.

Information contained in this publication may be considered confidential. Discretion is recommended when distributing. Materials and specifications are subject to change without notice.

CAT, CATERPILLAR, LET'S DO THE WORK, their respective logos, "Caterpillar Corporate Yellow," the "Power Edge" and Cat "Modern Hex" trade dress as well as corporate and product identity used herein, are trademarks of Caterpillar and may not be used without permission.

C9 ACERT™, C13 ACERT, C15 ACERT, C18 ACERT Circuit Breakers

Manually Operated Circuit Breakers

Current (A)	Frame	Number of Poles	Interrupting Ratings (kA rms)			Trip Units	(Lugs) Cable Size Range / Phase	Auxiliary Options
			240V	480V	600V			
100	H	3	65	35	18	Electronic LSI	8-3/0 AWG	Form C (1NO + 1NC) Shunt Trip 24VDC
250	J	3	65	35	18		(2) 3/0 – 250 kcmil	
400	T5N	3	65	25	18	Electronic LS/I (S or I) or LSI	(2) 3/0 – 250 kcmil	1 Form C + 1 Bell Alarm 250VAC/VDC Shunt Trip 24VDC
600	T6N	3	65	35	20		(3) 2/0 – 400 kcmil	
800	T6N	3	65	35	20		(3) 2/0 – 400 kcmil	1 Form C + 1 Bell Alarm 400VAC / 250VDC Shunt Trip 24VDC
1200	T7S	3	65	50	25		(4) 2/0 – 500 kcmil	
1600	R	3	65	35	18	Electronic LSI	BUS BAR	Form C (1NO + 1NC) Shunt Trip 24VDC
2000	R	3	65	35	18		BUS BAR	
2500	R	3	65	35	18		BUS BAR	
3000	R	3	65	35	18		BUS BAR	

Electrically Operated Circuit Breakers

Current (A)	Frame	Number of Poles	Interrupting Ratings (kA rms)			Trip Units	(Lugs) Cable Size Range / Phase	Auxiliary Options
			240V	480V	600V			
800	T 7M-S	3	65	50	25	Electronic LSI	(4) 4/0 – 500 kcmil	2 Form C + 1 Bell Alarm 24VDC
1200	T 7M-S	3	65	50	25	Electronic LSI	(4) 4/0 – 500 kcmil	2 Form C + 1 Bell Alarm 24VDC
2000	T8M-S	3	125	125	100	Electronic LSI	BUS BAR	2 Form C + 1 Bell Alarm 24VDC
3000	T8M-S	3	125	125	100	Electronic LSI	BUS BAR	2 Form C + 1 Bell Alarm 24VDC

Circuit Breakers



Single Breaker Options (250 – 3000A)

Model	Current (A)	Operation
C9 ACERT™	250	Manually Operated
C9 ACERT	400	Manually Operated
C9 ACERT, C13 ACERT, C15 ACERT, C18 ACERT	600	Manually Operated
C9 ACERT, C13 ACERT, C15 ACERT, C18 ACERT	800	Manually Operated or Electrically Operated
C9 ACERT, C13 ACERT, C15 ACERT, C18 ACERT	1200	Manually Operated or Electrically Operated
C13 ACERT, C15 ACERT, C18 ACERT	1600	Manually Operated
C15 ACERT, C18 ACERT	2000	Manually Operated or Electrically Operated
C18 ACERT	2500	Manually Operated
C18 ACERT	3000	Manually Operated or Electrically Operated

Multiple Breaker Options

Model	Main Breaker Box		Auxiliary Box
	1st Breaker (Amps)	2nd Breaker (Amps)	Breaker (Amps)
	Manually Operated	Manually Operated	Manually Operated
C9 ACERT, C13 ACERT, C15 ACERT, C18 ACERT	250	250, 400, 600, 800, or 1200	3rd Breaker: 250 or 400 (Not available if 1st & 2nd Breaker = 1200A)
C9 ACERT, C13 ACERT, C15 ACERT, C18 ACERT	400		
C9 ACERT, C13 ACERT, C15 ACERT, C18 ACERT	600		
C9 ACERT, C13 ACERT, C15 ACERT, C18 ACERT	800		
C9 ACERT, C13 ACERT, C15 ACERT, C18 ACERT	1200		
C13 ACERT, C15 ACERT, C18 ACERT	1600	Not Available	2nd Breaker: 250 or 400
C15 ACERT, C18 ACERT	2000		
C18 ACERT	2500		
C18 ACERT	3000		

H-Frame Circuit Breakers

Electronic Trip Unit Long Time / Short Time Trip Curve

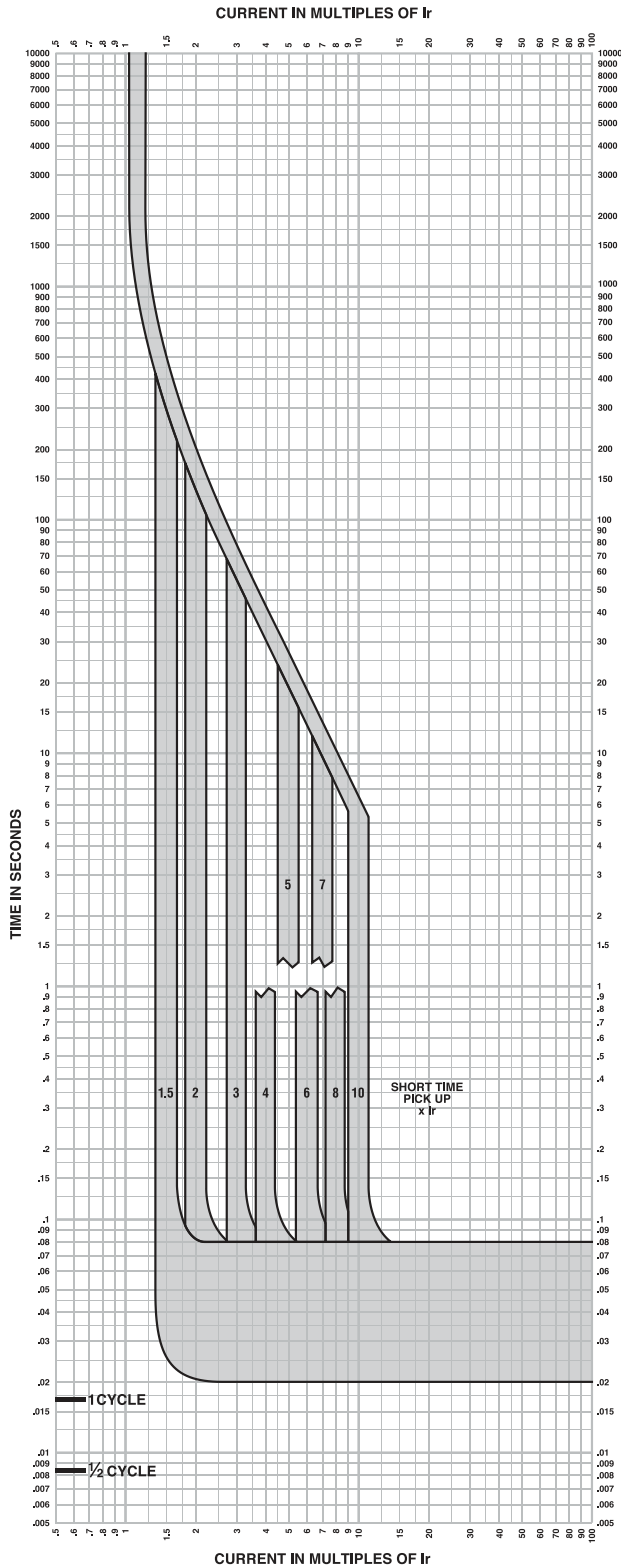

**Long Time/Short Time Trip Curve
60A, 100A, 150A H-Frame**

The time-current curve information is to be used for application and coordination purposes only.

Notes:

1. There is a thermal-imaging effect that can act to shorten the long-time delay. The thermal imaging effect comes into play if a current above the long-time delay pickup value exists for a time and then is cleared by the tripping of a downstream device or the circuit breaker itself. A subsequent overload will cause the circuit breaker to trip in a shorter time than normal. The amount of time delay reduction is inverse to the amount of time that has elapsed since the previous overload. Approximately 20 minutes is required between overloads to completely reset thermal-imaging.
2. Total clearing times shown include the response times of the trip unit, the circuit breaker opening, and the extinction of the current.

Curves apply from -35°C to +70°C (-31°F to +158°F) ambient temperature.

Figure 1

H-Frame Circuit Breakers

Electronic Trip Unit Instantaneous Trip Curve

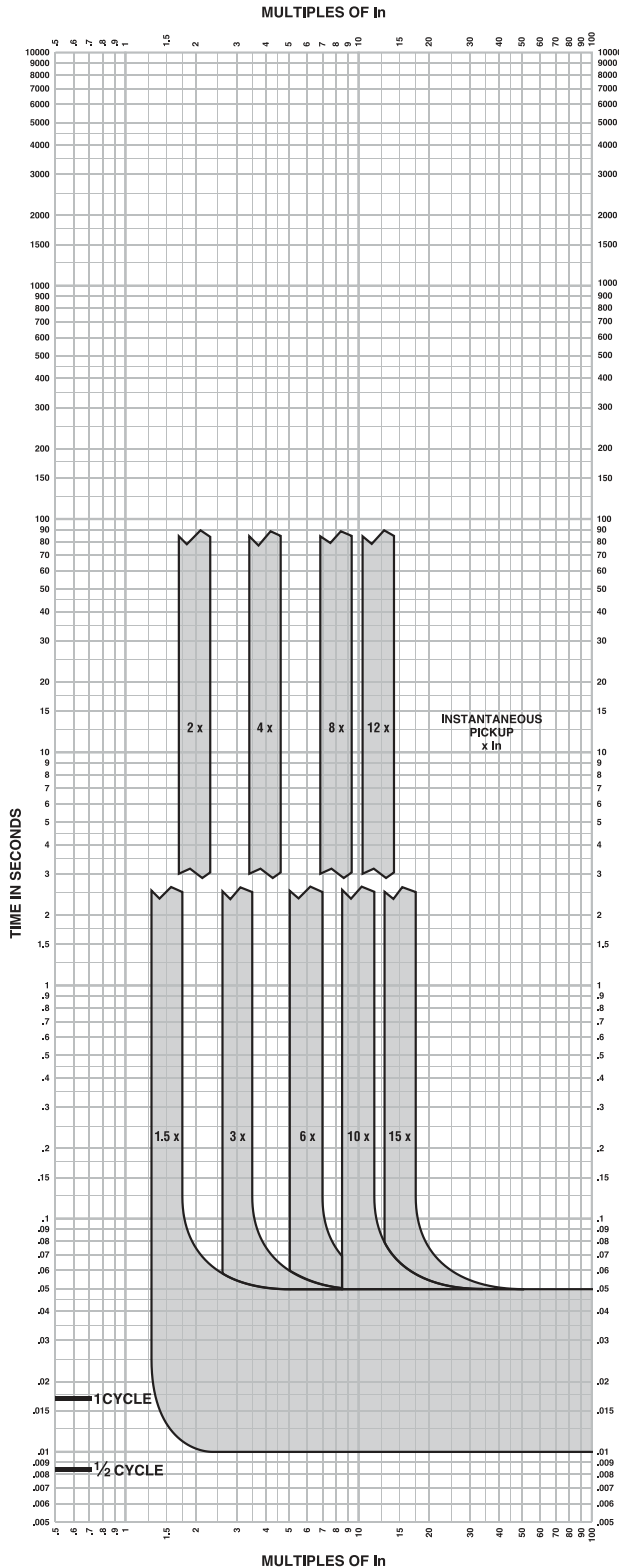

Instantaneous Trip Curve 60A, 100A, 150A H-Frame

The time-current curve information is to be used for application and coordination purposes only.

Notes:

1. There is a thermal-imaging effect that can act to shorten the long-time delay. The thermal imaging effect comes into play if a current above the long-time delay pickup value exists for a time and then is cleared by the tripping of a downstream device or the circuit breaker itself. A subsequent overload will cause the circuit breaker to trip in a shorter time than normal. The amount of time delay reduction is inverse to the amount of time that has elapsed since the previous overload. Approximately 20 minutes is required between overloads to completely reset thermal-imaging.
 2. Total clearing times shown include the response times of the trip unit, the circuit breaker opening, and the extinction of the current.
 3. In = Maximum dial setting of Ir.
60A H-Frame: In = 60A = Max Ir setting
100A H-Frame: In = 100A = Max Ir setting
150A H-Frame: In = 150A = Max Ir setting
- Curves apply from -35°C to +70°C (-31°F to +158°F) ambient temperature.

Figure 2

J-Frame 250 A Typical Peak Let-Through Curves

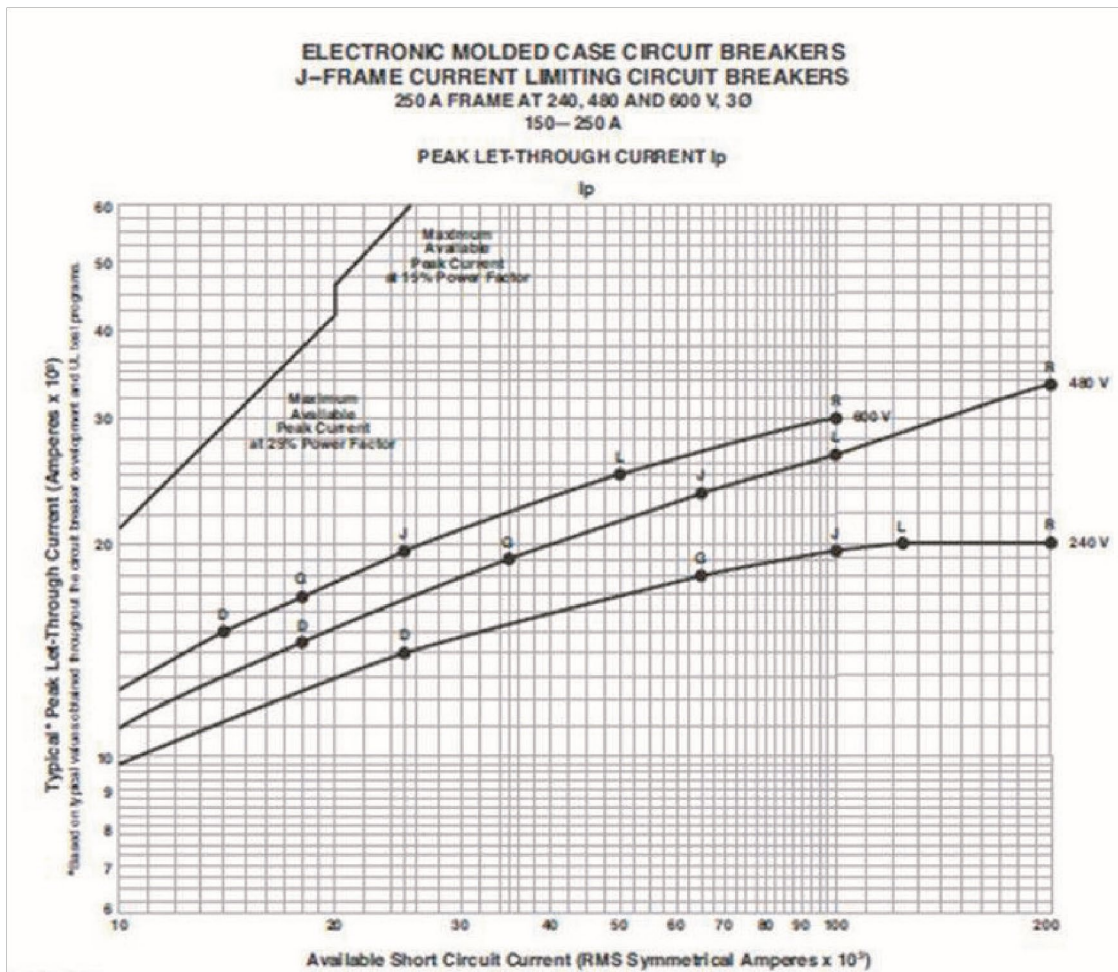

Figure 3

J-Frame 150-250 A (JD, JG, JJ, JL, and JR) Thermal-Magnetic Trip

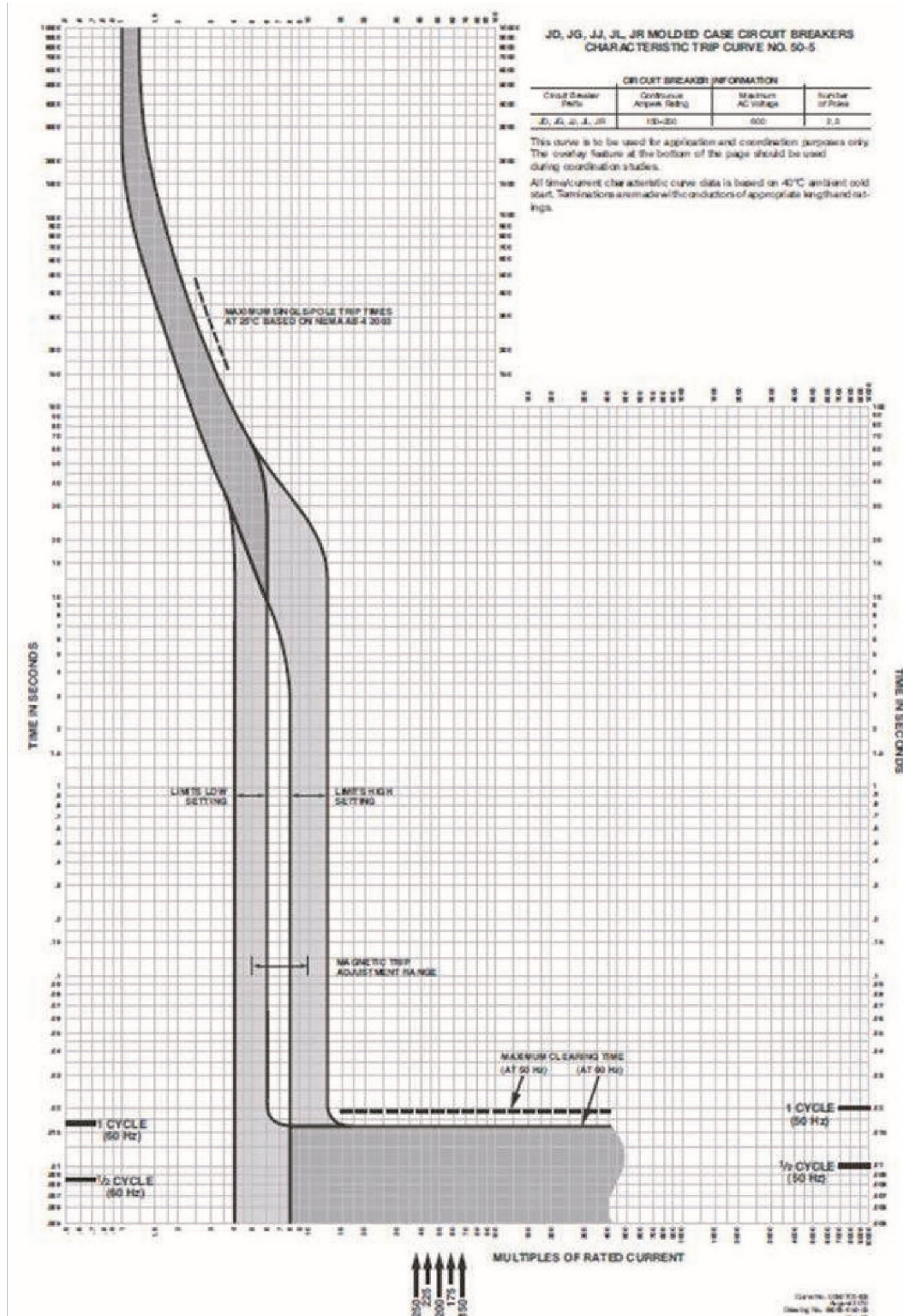

Figure 4

Ground Fault Module GFM250JD Trip Curve

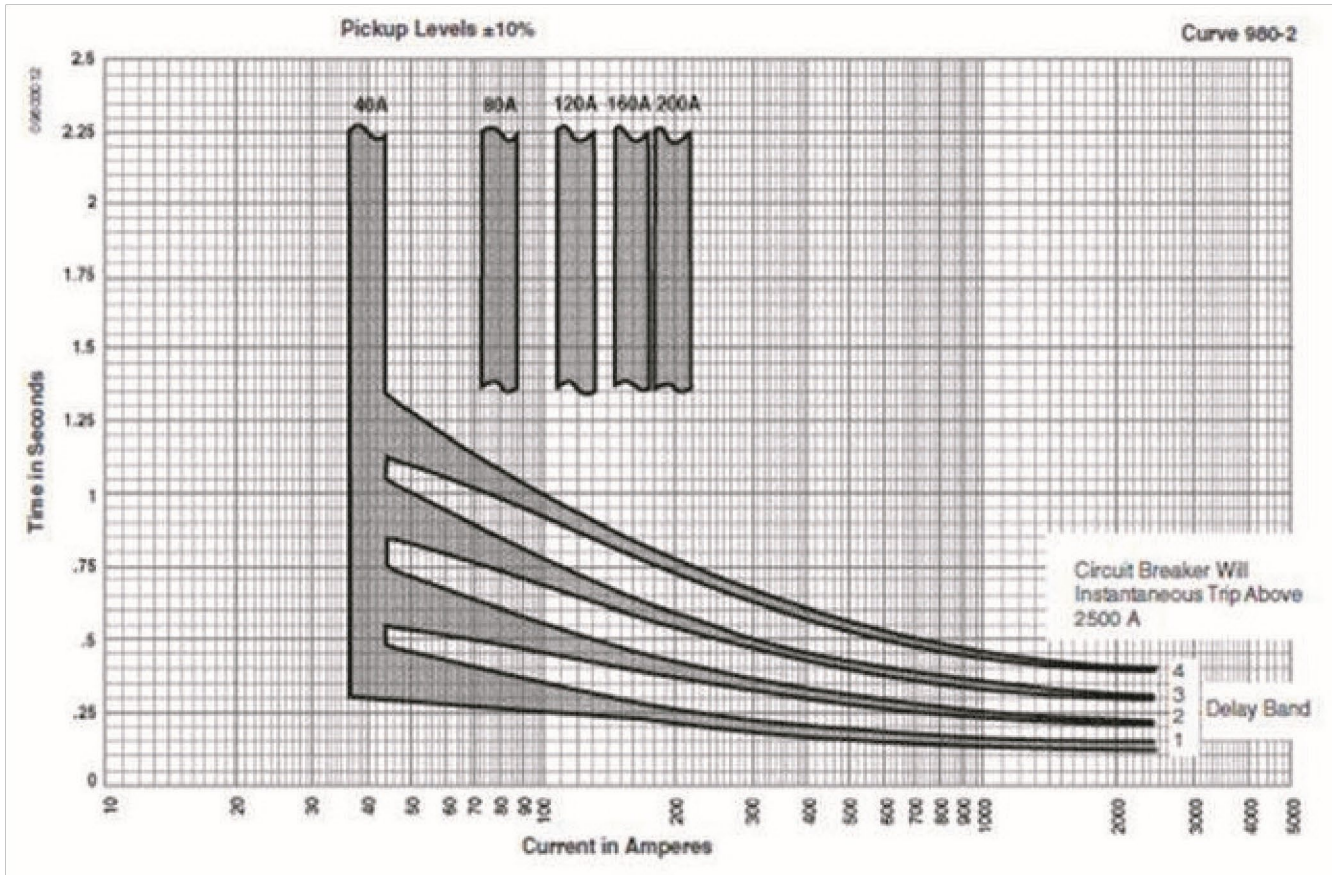

Figure 5

T5 400/ 600 – PR221DS

Tmax T5 Ekip E
L-S-I Functions

Tmax T5 Ekip E
L-S-I Functions

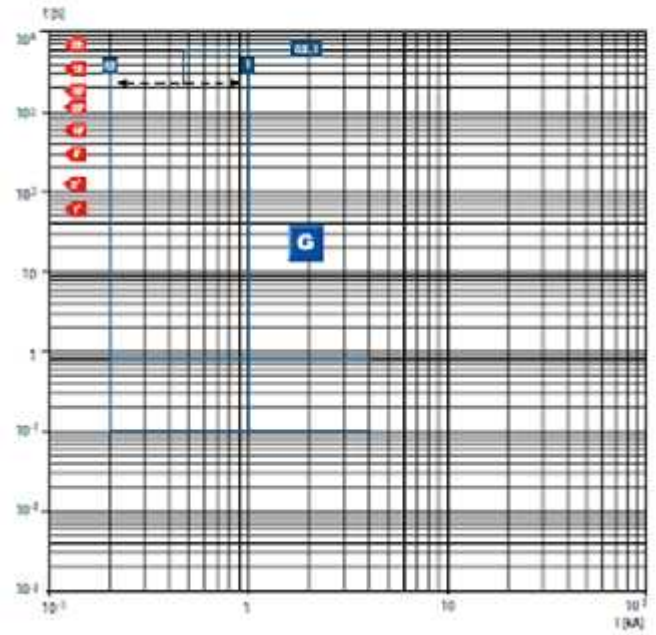
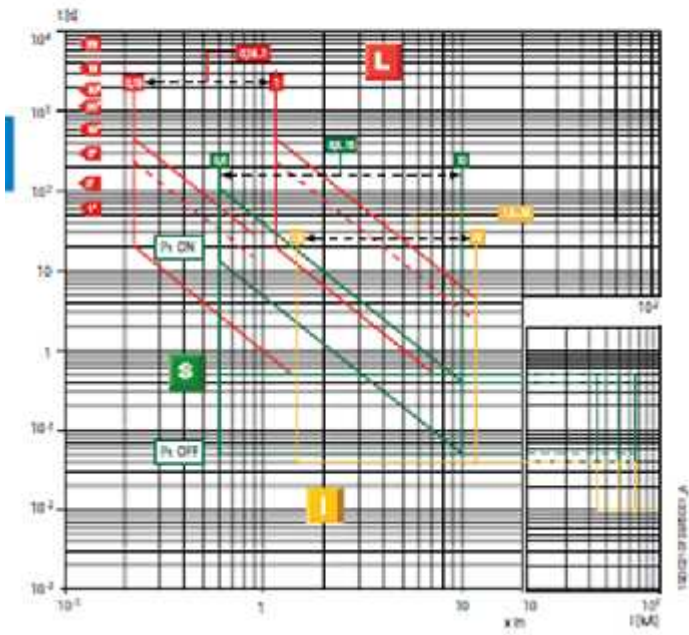

Figure 6

T6 600 / 800 -PR221DS

L-S Functions

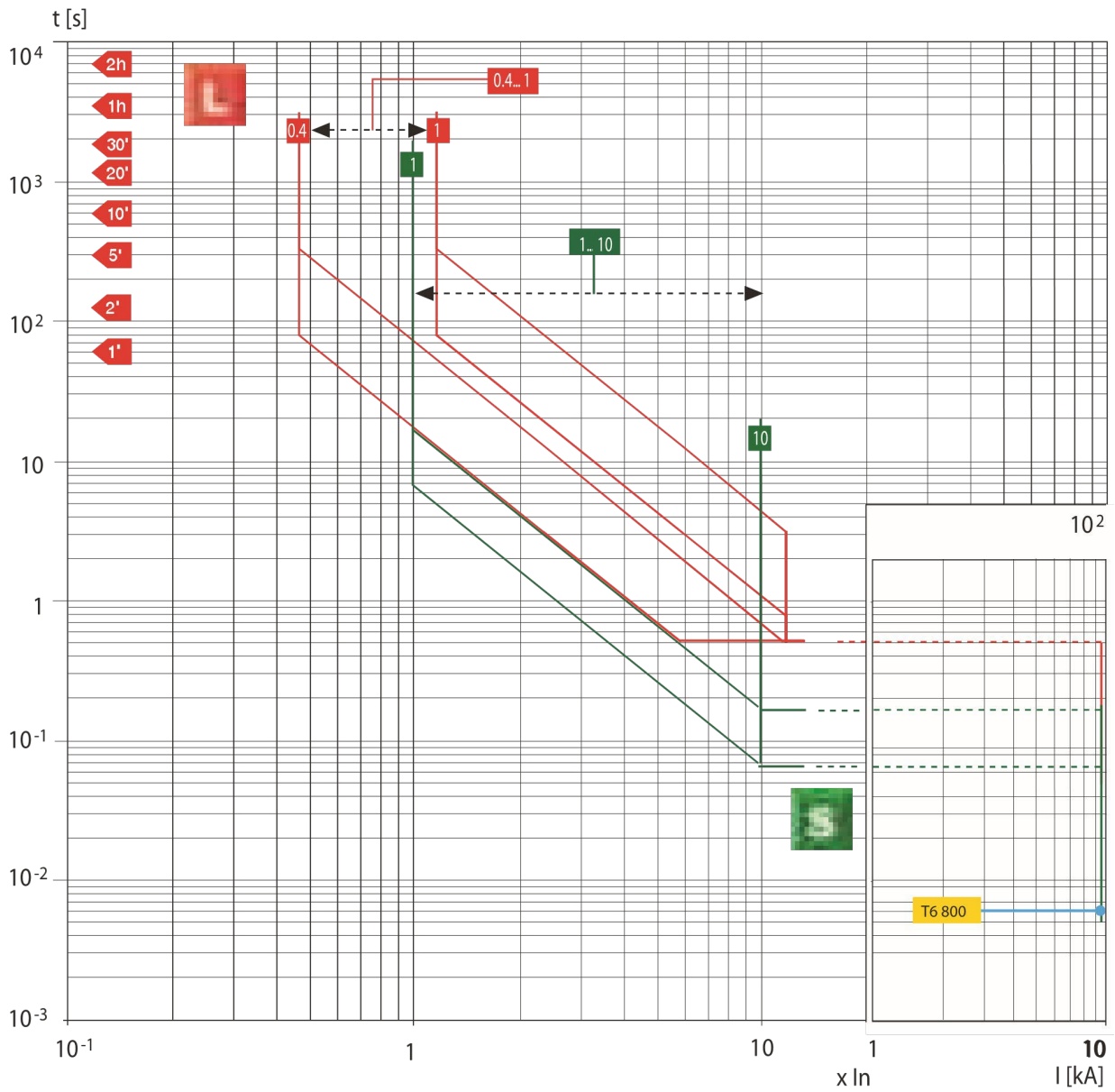

Figure 8

Tmax T7 PR231/P Functions L-S Functions

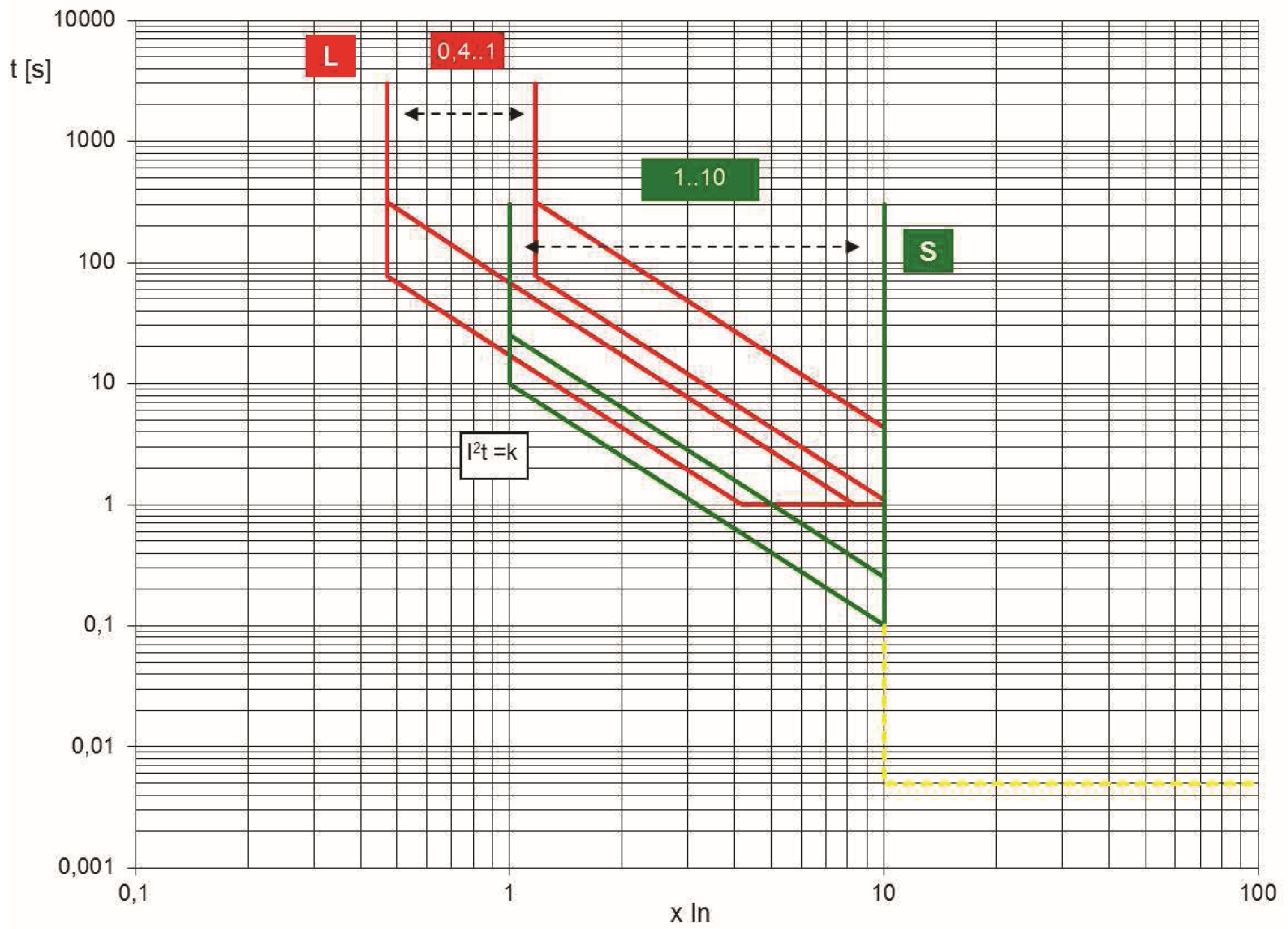

Figure 9

T6 800 - PR222DS and PR222DS/PD-A L-S-I Functions

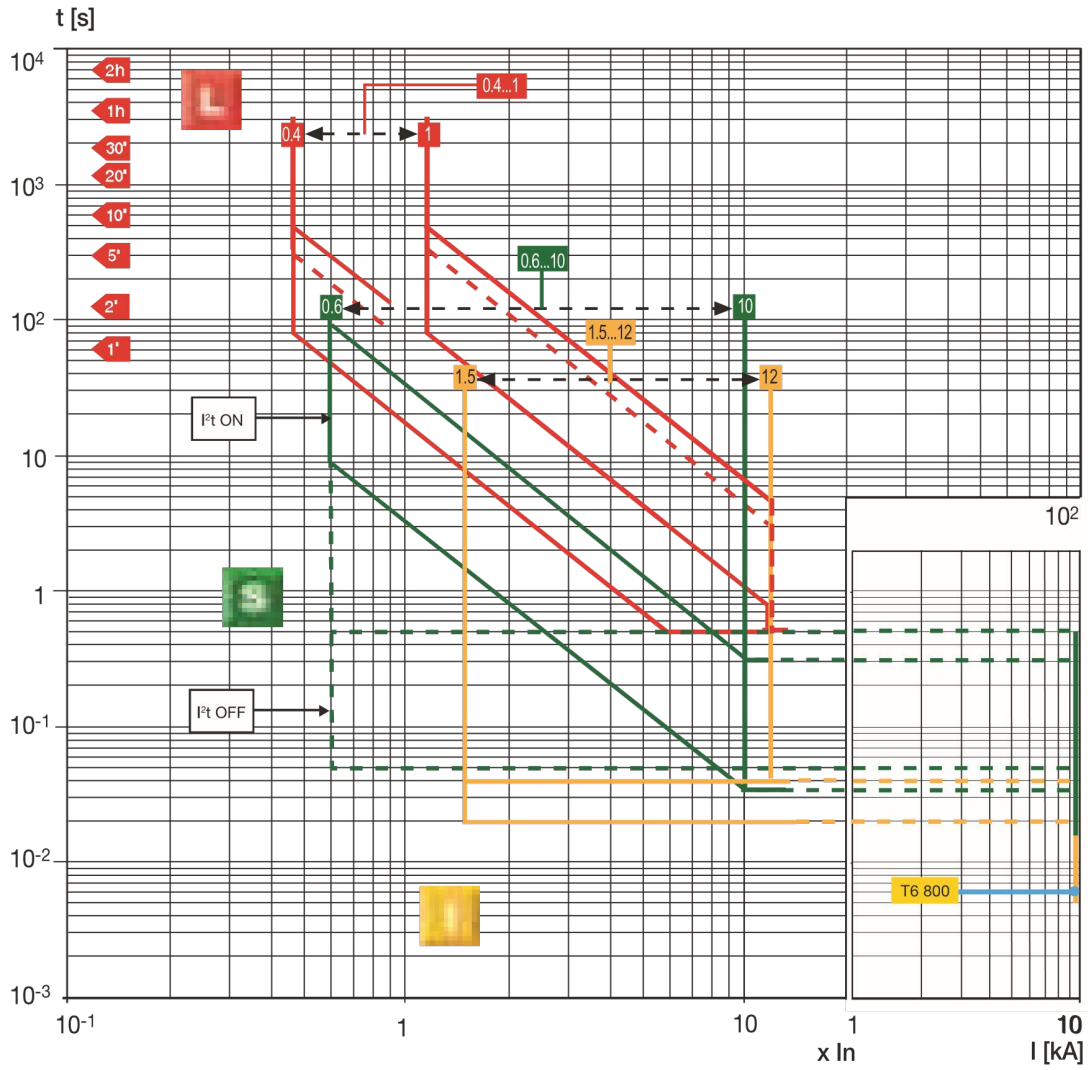

Figure 10

T7 1000/1200 - PR232/P L-S-I Functions

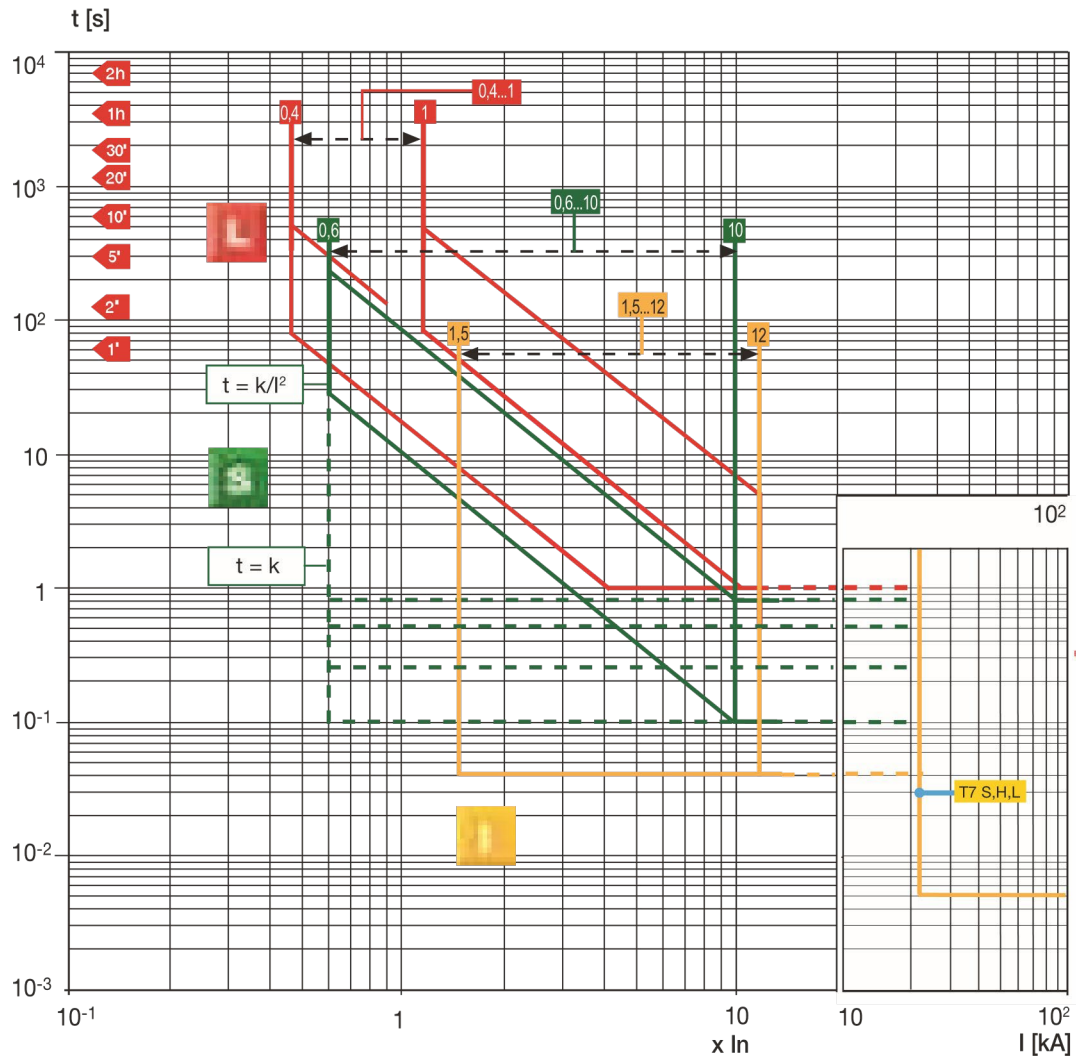

Figure 11

T7 1000/1200 - PR332/P L-S-I Functions

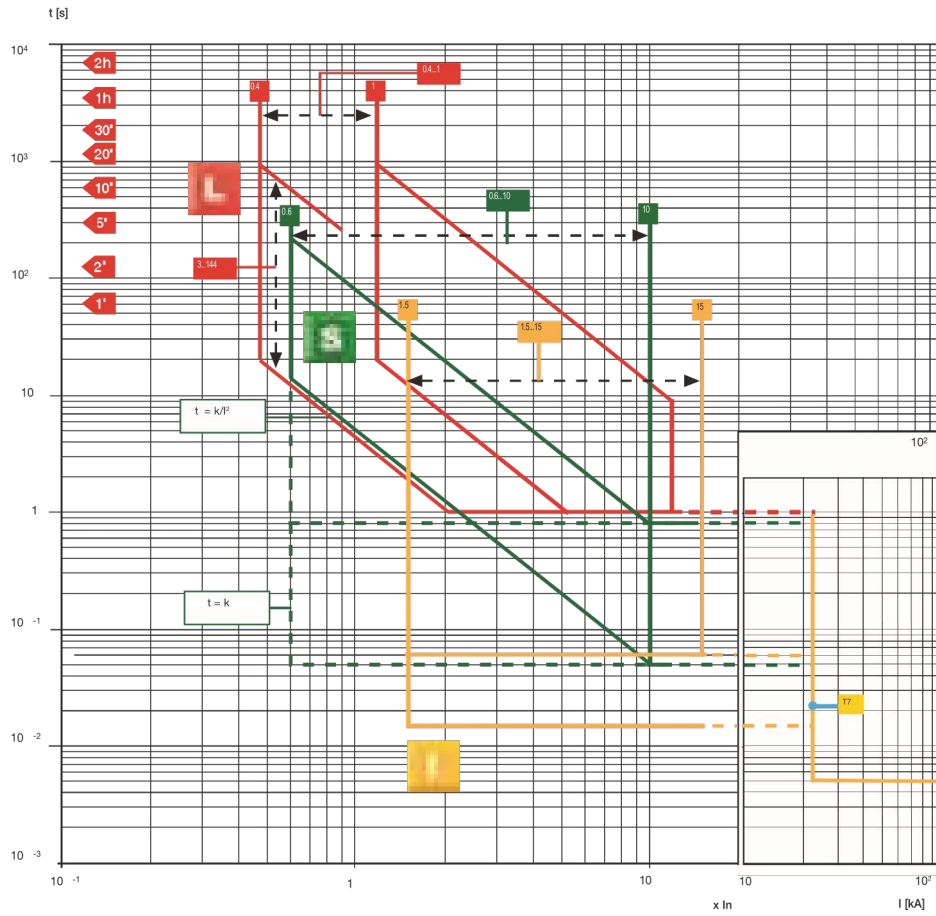

Figure 12

Circuit Breakers



T8 1600/2000/2500/3000 – PR232/P-T8
 L-S-I Functions

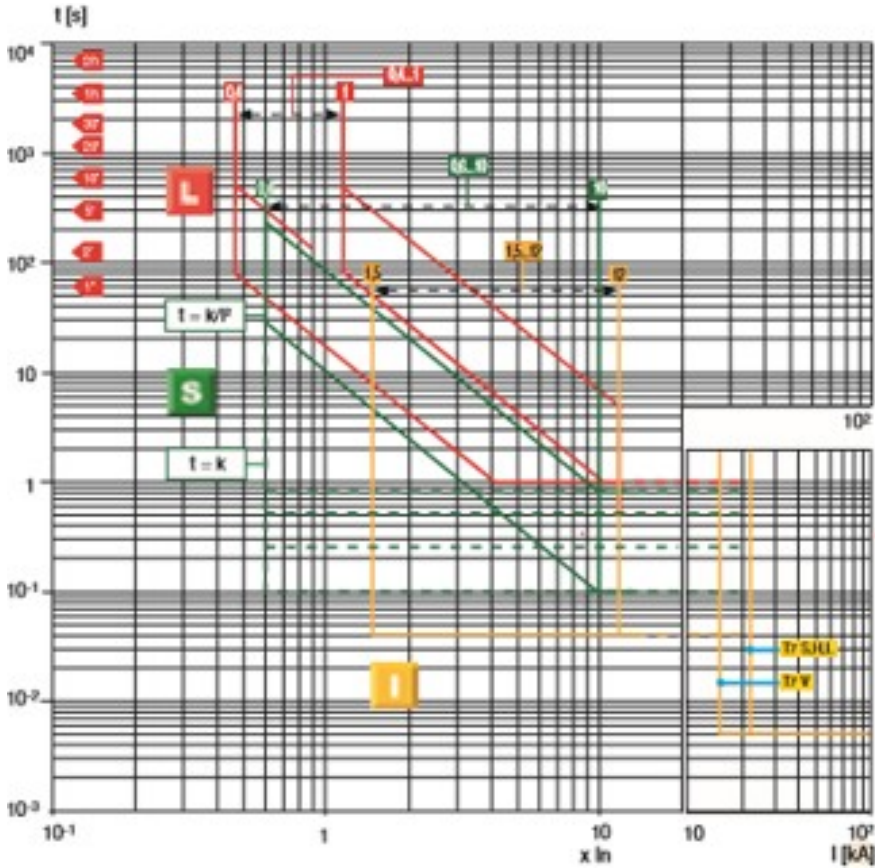

Figure - 13

P, R, NS-Frame Long-Short Trip Curve and NW-Frame Long-Short Trip Curve

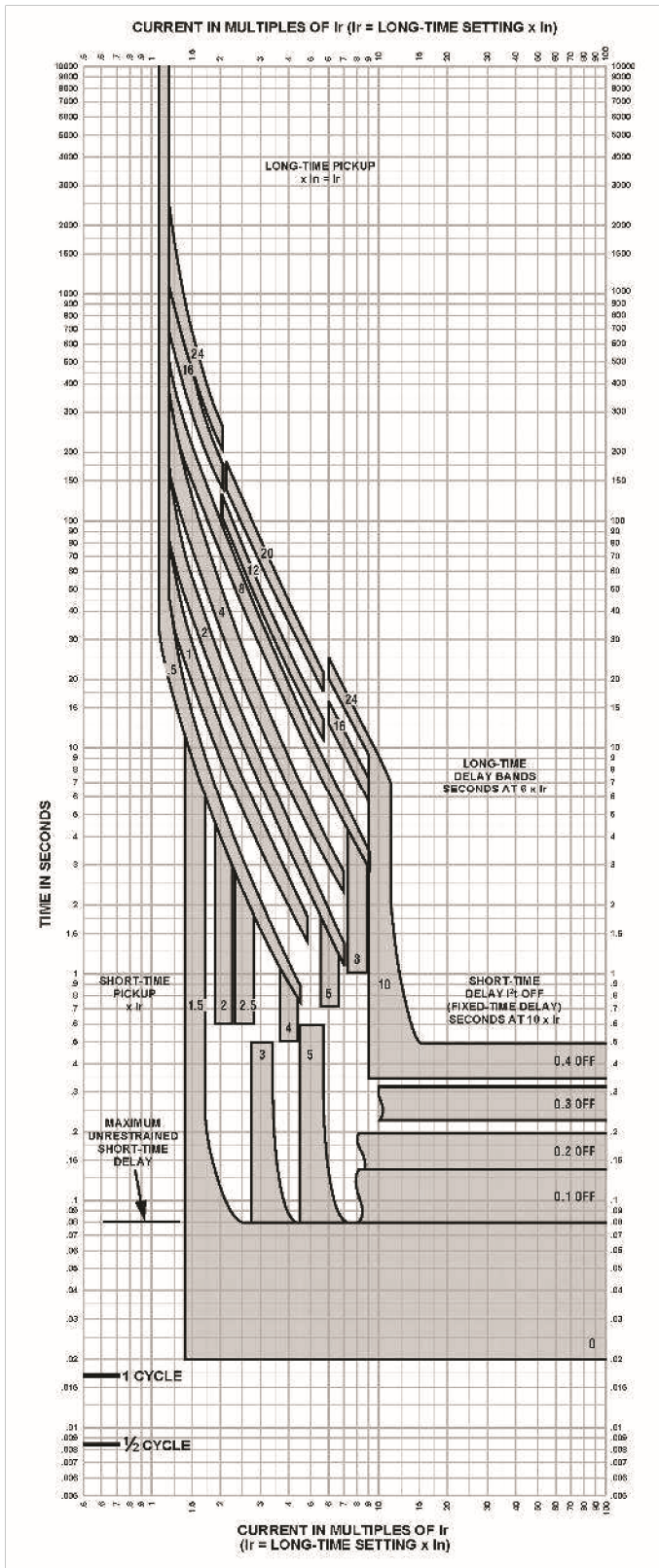

Figure - 14

Long-time Pickup and Delay Short-time Pickup and I²t OFF Delay

The time-current curve information is to be used for application and coordination purposes only. Curves apply from -30°C to +60°C ambient temperature.

Notes:

1. There is a thermal-imaging effect that can act to shorten the long-time delay. The thermalimaging effect comes into play if a current above the long-time delay pickup value exists for a time and then is cleared by the tripping of a downstream device or the circuit breaker itself. A subsequent overload will cause the circuit breaker to trip in a shorter time than normal. The amount of time delay reduction is inverse to the amount of time that has elapsed since the previous overload. Approximately 20 minutes is required between overloads to completely reset thermal-imaging.
2. The end of the curve is determined by the interrupting rating of the circuit breaker.
3. With zone-selective interlocking on, short-time delay utilized and no restraining signal, the maximum unrestrained short-time delay time band applies regardless of the setting.
4. Total clearing times shown include the response times of the trip unit, the circuit breaker opening, and the extinction of the current.
5. For a withstand circuit breaker, instantaneous can be turned OFF. See Page 22 for instantaneous trip curve. See tables on pages 03-18 for instantaneous override values..
6. Overload indicator illuminates at 100%.

P, R, NS-Frame Instant Curve and NW-Frame Instant Trip Curve

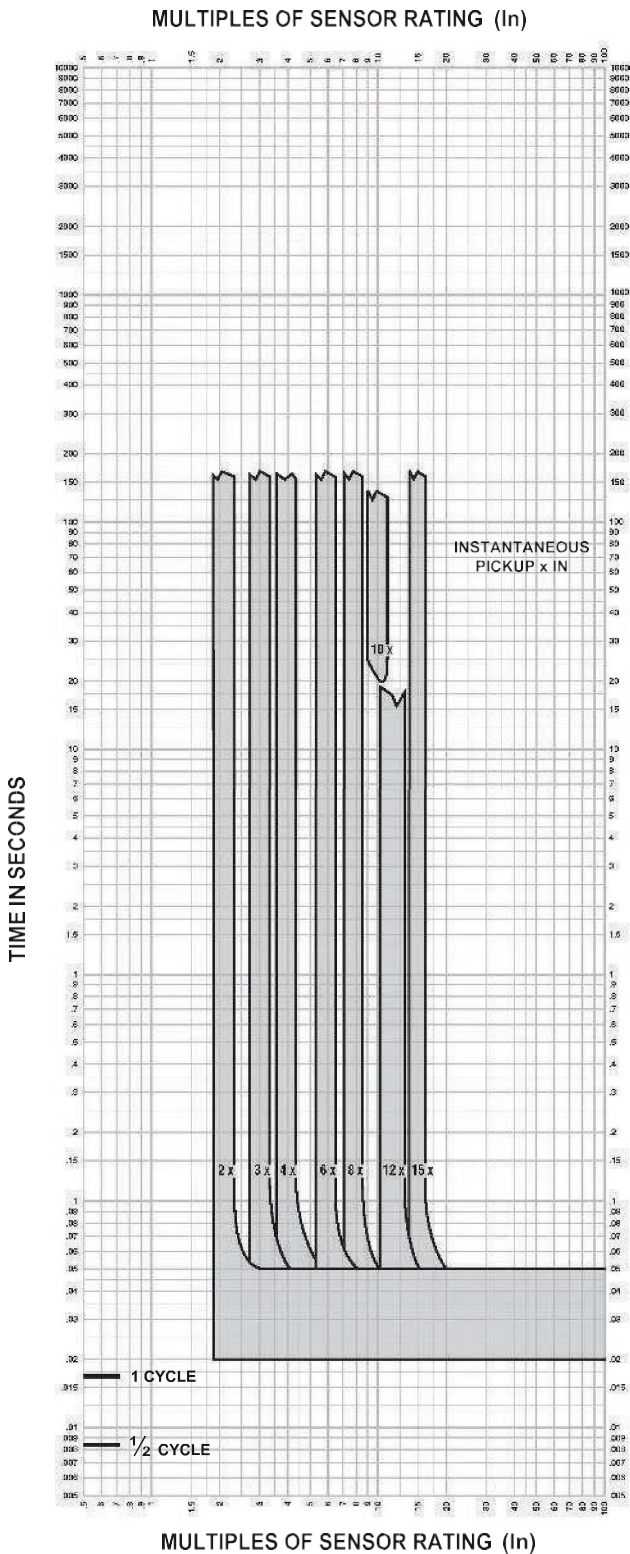

Figure 15

Instantaneous Pickup 2x–15x and OFF

The time-current curve information is to be used for application and coordination purposes only.

Curves apply from -30° to +60°C ambient temperature.

Notes:

1. The end of the curve is determined by the interrupting rating of the circuit breaker.
2. Total clearing times shown include the response times of the trip unit, the circuit breaker opening, and the extinction of the current.
3. The instantaneous region of the trip curve shows maximum total clearing times. Actual clearing times in this region can vary depending on the circuit breaker mechanism design and other factors. The actual clearing time can be considerably faster than indicated. Contact your local Sales Office for additional information.
4. For a withstand circuit breaker, instantaneous can be turned OFF. See tables on pages 03-18 for instantaneous override values.
5. See page 22 for long-time pickup, long-time delay, short-time pickup, and short time delay trip curves.

P, R, NS-Frame Ground Curve and NW-Frame Ground Fault Trip Curve

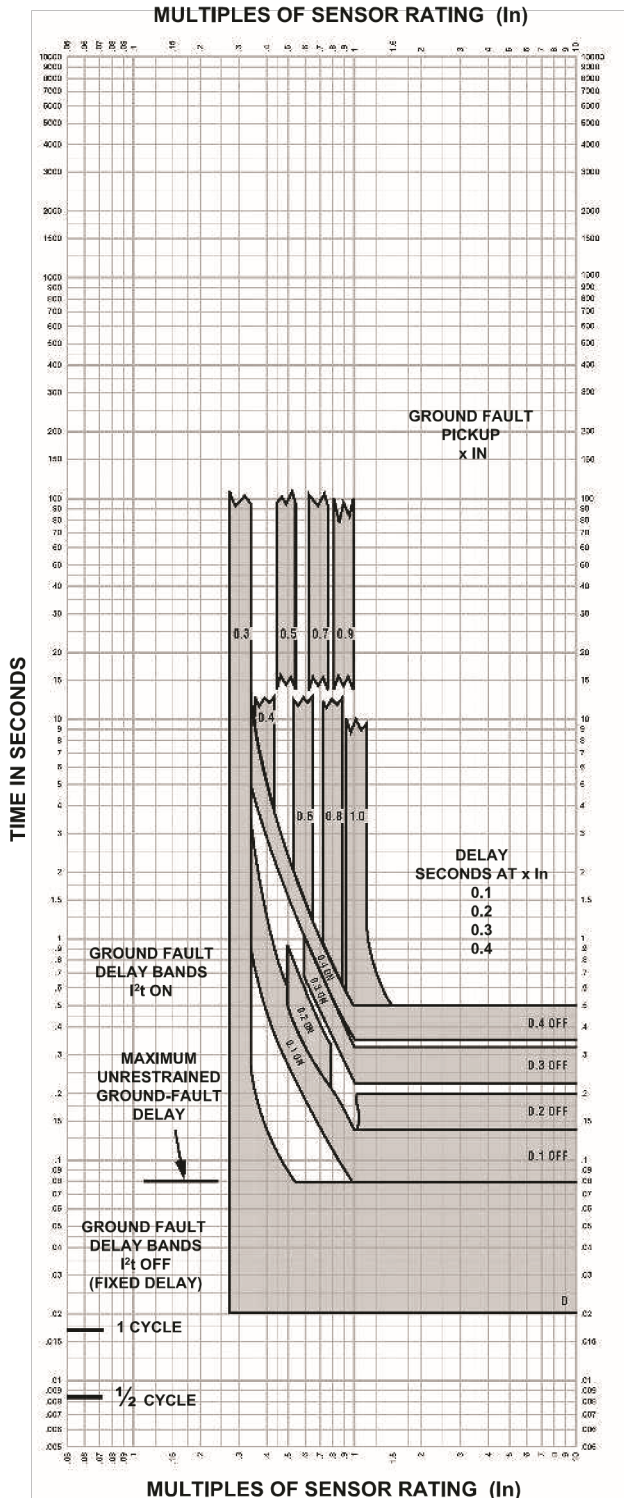

Ground-fault I²t OFF and ON In ≤ 400 A

The time-current curve information is to be used for application and coordination purposes only.

Curves apply from -30°C to +60°C ambient temperature.

Figure - 16

LET'S DO THE WORK.™

LEHE0942-06 (05-20)

www.Cat.com/electricpower
 © 2020 Caterpillar. All Rights Reserved. CAT, CATERPILLAR, LET'S DO THE WORK, their respective logos, "Caterpillar Corporate Yellow", the "Power Edge" and Cat "Modern Hex" trade dress as well as corporate and product identity used herein, are trademarks of Caterpillar and may not be used without permission

Note : The Information on this Document comes from a Third Party Supplier and is not a Caterpillar Material



Jacket Water Heater (WHHH01/WHHH03)

Appropriate when the generator set is to be sited in a low ambient environment, the heater maintains the engine coolant at a temperature [typically 38°C (100°F)] which facilitates rapid starting and load acceptance. The heater assembly uses UL compliant components (to UL1030) and has CSA certification which is to both CSA and UL Standards.

The heater itself is powered by a 240V for 60 Hz AC auxiliary supply. A thermostatic controller is included to regulate the output temperature to within safe limits. When the generator set is not running the heater is automatically connected to the AC supply through a power relay mounted in the control panel.

Upon receiving a start signal the AC supply is automatically disconnected by the power relay and automatically reconnected when the start signal is removed, and the engine has stopped.

Features

- Uniform heat distribution
- Reduces wear from cold spots
- Improves startability
- Thermostatically controlled and protected
- 6' (1.8m) cord length (577-1758)
- 16.4' (5.0m) cord length (578-9355).
- Ensures generator is at optimal starting temperature and ready to accept load
- Durable pump with non-magnetic impeller that does not attract metal debris
- Robust die cast aluminum housing improves sealing of the hoses, eliminates leaking and breakage
- Corrosion resistant steel brackets for superior strength and durability
- Reduces thermal stress on coolant hoses
- Element designed for long life with maximum heat transfer
- IP44 Ingress Protection Rating
- No evaporation of coolant from hoses
- Reduces low coolant level alarms because coolant does not boil

Part No	Outlet Location	Watts	Volts	Amps	Regulating Thermostat	Safety Thermostat
577-1758/578-9355	Right	2700	240	11.25	On 90°F (32°C) Off 115°F (46°C)	210°F (98°C)

www.cat.com/electricpower
©2020 Caterpillar
All rights reserved.

Information contained in this publication may be considered confidential. Discretion is recommended when distributing. Materials and specifications are subject to change without notice.

CAT, CATERPILLAR, LET'S DO THE WORK, their respective logos, "Caterpillar Corporate Yellow," the "Power Edge" and Cat "Modern Hex" trade dress as well as corporate and product identity used herein, are trademarks of Caterpillar and may not be used without permission.



Image shown might not reflect actual configuration

SPECIFICATION

AC SUPPLY

VOLTAGE RANGE 90 V to 305 V (L-N)

FREQUENCY RANGE

48 Hz to 64 Hz (L-N)

DC OUTPUT RATING

10 A DC at 24 V DC

RIPPLE AND NOISE

<1%

EFFICIENCY

>86%

REGULATION LINE

<0.5%

LOAD

2%

TEMPERATURE SENSOR INPUT

PT1000

PROTECTIONS

Short Circuit
DC Over Voltage
DC Over Current
Reverse Polarity
Over Temperature
AC Under & Over Voltage

CHARGE FAILURE RELAY

3 A at 30 V DC volt free relay

DIMENSIONS OVERALL

70 mm x 200 mm x 130 mm
2.7" x 7.9" x 5.1"

WEIGHT

0.75 kg

OPERATING TEMPERATURE RANGE

-30 °C to +80 °C
-22 °F to +176 °F

STORAGE TEMPERATURE RANGE

-40 °C to +70 °C
-22 °F to +158 °F

BATTERY CHARGER

The intelligent battery charger has been developed with safety, usability, optimised battery performance and maximum battery lifetimes in mind.

A comprehensive range of input and output protections ensures a continued safe charging environment also enabling the use of the charger as a power supply.

FEATURES

- Intelligent two, three and four stage charging profiles
- Configurable to suit most battery types (12V/24V)
- Adjustable current limit
- Can be used as a battery charger, power supply or both at the same time
- Automatic or Manual boost and storage charge functions to help maintain battery condition
- Digital Microprocessor Technology
- Temperature compensation for battery charging
- Low Output Ripple and superb line regulation
- Three LED Indicators
- AC input Under voltage
- AC input Over voltage
- Battery charger output Over voltage
- Battery charger output Over current
- Optional battery temperature compensation with over temperature protection
- Output short circuit and Inversion polarity with auto recovery
- Configurable charge termination
- UL1236 /UL1564 Compliant

Automatic Boost Mode

- Boosts and equalises cell charge improving battery performance and life

Power Save Mode

- Once the battery is fully charged the chargers switch to Eco-Power to save energy

Communication

- Can be integrated into external systems through MODBUS RTU using RS485
- Fully configurable via PC Software

BENEFITS

- Fully flexible to maximise the life of the battery
- Suitable for a wide range of battery types
- Switched mode design
- Minimum 86% efficiency throughout full operating range
- No external intervention for boost mode
- Multiple chargers can be linked together to provide larger current output
- Can be permanently connected to battery and mains (utility) supply. No need to disconnect through high load conditions.

LEHE2022-02 (10-20)



Image shown may not reflect actual configuration.

20A Tamper-Resistant, Weather-Resistant GFCI Receptacles

Features and Benefits

- Automatically tests the GFCI every time the reset button is pushed in. The GFCI will not reset if the GFCI circuit is not functioning properly.
- By blocking reset of the GFCI if protection has been compromised, SmartLockPRO reduces the possibility of end-users incorrectly assuming that a reset GFCI outlet is providing ground fault protection when it actually is not.
- A line-load reversal diagnostic feature is provided which prevents the GFCI from being reset and stops power from being fed to the GFCI receptacle face or through to downstream devices. A green LED indicator on the GFCI's face also illuminates to alert the installer to the line-load wiring reversal.

Weather-Resistant GFCIs

- Meet UL 498 requirements for weather-resistant receptacles.

Tamper-Resistant GFCIs

- Shutter mechanism inside the receptacle blocks access to the contacts unless a two-prong plug is inserted, helping ensure foreign objects will be locked out.

Product Features

- Grounding: GFCI ground fault
- Feature: Weather and tamper-resistant
- Amperage: 20 Amp
- Voltage: 125 Volt
- NEMA: 5-20R
- Trip Level: Class A, 5mA plus or minus 1mA
- Pole: 2
- Wire: 3
- Color: White

Standards and Certifications

- NEMA: WD-6
- ANSI: C-73
- UL498: File E13399
- CSA C22.2 No. 42: File LR-57811
- NOM: 057
- UL 943: File E48380

Receptacles contained in a weather resistant box and in-use cover.



www.Cat-ElectricPower.com

©2016 Caterpillar
All rights reserved.

Materials and specifications are subject to change without notice.

CAT, CATERPILLAR, their respective logos, "Caterpillar Yellow", the "Power Edge" trade dress as well as corporate and product identity used herein, are trademarks of Caterpillar and may not be used without permission.



Image shown might not reflect actual configuration

Remote Annunciator Module

It is an LED expansion module that can be used with compatible control modules. The module has been designed to display a maximum of eight individual LED indications up to a maximum distance of 1 KM (0.6 miles).

The Annunciator will consist of two modules to provide a 16 Channel Fault annunciation.

It is presented in a vertical enclosure. It includes an alarm sounder that is triggered when the host controller detects an alarm condition. The alarm can be muted using the front push button.

The Panels will be fitted with removable label cards which can be used to identify the standard NFPA alarms. If desired

It includes individual LEDs for each channel and a 'Power On' LED that flashes when the link with the host controller is lost.

FEATURES

- The Remote annunciator has an integral Sounder / Horn
- Eight configurable LEDs (per module)
- Works up to 1 KM (0.6 miles) from the host controller
- A single Controller can support five Caterpillar Configured remote annunciator control boxes

LEHE2021-01 (03-21)

www.Cat.com/electricpower

©2021 Caterpillar All rights reserved. Materials and specifications are subject to change without notice. The International System of Units (SI) is used in this publication. CAT, CATERPILLAR, their respective logos, "Caterpillar Corporate Yellow", the "Power Edge" and Cat "Modern Hex" trade dress as well as corporate and product identity used herein, are trademarks of Caterpillar and may not be used without permission.

ENVIRONMENTAL TESTING STANDARDS

ELECTRO-MAGNETIC COMPATIBILITY

BS EN 61000-6-2
EMC Generic Immunity Standard for the Industrial Environment
BS EN 61000-6-4
EMC Generic Emission Standard for the Industrial Environment

ELECTRICAL SAFETY

BS EN 60950
Safety of Information Technology Equipment, including Electrical Business Equipment

TEMPERATURE

BS EN 60068-2-1
Ab/Ae Cold Test -30 °C BS EN 60068-2-2
Bb/Be Dry Heat +70°C

VIBRATION

BS EN 60068-2-6
Ten sweeps in each of three major axes
5 Hz to 8 Hz @ +/-7.5 mm, 8 Hz to 500 Hz @ 2 gn

SHOCK

BS EN 60068-2-27
Three shocks in each of three major axes 15 gn in 11 Ms

HUMIDITY

BS EN 60068-2-30
Db Damp Heat Cyclic 20/55 °C @ 95% RH 48 Hours
BS EN 60068-2-78
Cab Damp Heat Static 40 °C @ 93% RH 48 Hours

DEGREES OF PROTECTION PROVIDED BY ENCLOSURES BS EN 60529

IP65 - Front of module when installed into the control panel with the supplied sealing gasket.

SPECIFICATION

CONTINUOUS VOLTAGE RATING

8 V to 35 V Continuous

CRANKING DROPOUTS

Able to survive 0 V for 50 mS, providing supply was at least 10 V before dropout and supply recovers to 5 V. This is achieved without the need for internal batteries. LEDs and backlight will not be maintained during cranking.

MAXIMUM OPERATING CURRENT

112 mA at 12 V, 53 mA at 24 V

MAXIMUM STANDBY CURRENT

74 mA at 12 V, 35 mA at 24 V

DIMENSIONS OVERALL

355 mm x 369 mm x 90 mm
13.97" x 14.52" x 3.54"

PANEL CUT-OUT

286 mm x 326 mm x 93 mm
11.25" x 12.83" x 3.66"

MAXIMUM PANEL THICKNESS

8 mm
0.3"

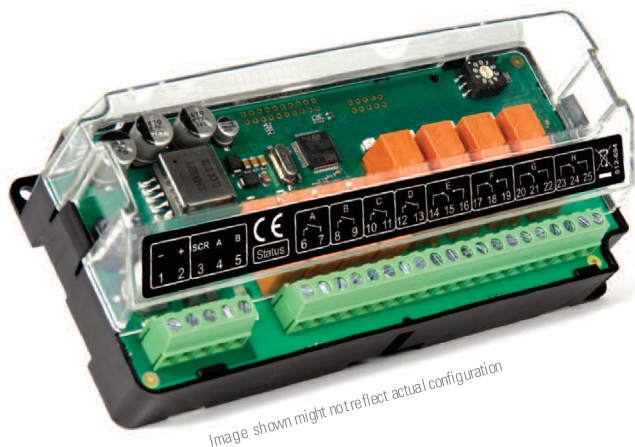

OUTPUT EXPANSION MODULE

Output relay expansion module for use with compatible control modules. The Output Expansion module has been designed to extend a host module's output capabilities.

A maximum of 10 Output Expansion modules can be connected to an individual module at any one time. All outputs are configurable via the host controller.

The module will work up to 1 KM (0.6miles) from the host control module

FEATURES

- Power On/Link Lost LED ID SWITCH
- 10 expansion modules can be connected to 1 host controller at a time
- 8 configurable relay contacts with LED indicators:
- 4 Normally Open (N/O)
- 4 Change Over (C/O)
- Terminal strip connection for quick and easy set-up

ENVIRONMENTAL TESTING STANDARDS

ELECTRO-MAGNETIC COMPATIBILITY

BS EN 61000-6-2
EMC Generic Immunity Standard for the Industrial Environment
BS EN 61000-6-4
EMC Generic Emission Standard for the Industrial Environment

ELECTRICAL SAFETY

BS EN 60950
Safety of Information Technology Equipment, including Electrical Business Equipment

TEMPERATURE

BS EN 60068-2-1
Ab/Ae Cold Test -30 °C BS EN 60068-2-2
Bb/Be Dry Heat +70°C

VIBRATION

BS EN 60068-2-6
Ten sweeps in each of three major axes
5 Hz to 8 Hz @ +/-7.5 mm, 8 Hz to 500 Hz @ 2 gn

SHOCK

BS EN 60068-2-27
Three shocks in each of three major axes 15 gn in 11 Ms

HUMIDITY

BS EN 60068-2-30
Db Damp Heat Cyclic 20/55 °C @ 95% RH 48 Hours
BS EN 60068-2-78
Cab Damp Heat Static 40 °C @ 93% RH 48 Hours

SPECIFICATION

CONTINUOUS VOLTAGE RATING

8 V to 35 V Continuous

CRANKING DROPOUTS

Able to survive 0 V for 50 mS, providing supply was at least 10 V before dropout and supply recovers to 5 V. This is achieved without the need for internal batteries. LEDs and backlight will not be maintained during cranking.

MAXIMUM OPERATING CURRENT

325 mA at 12 V, 152 mA at 24 V

MAXIMUM STANDBY CURRENT

70 mA at 12 V, 32 mA at 24 V

AUXILIARY RELAY CONTACTS

2 Amp DC rated voltage free

DIMENSIONS OVERALL

165 mm x 76 mm x 49 mm
6.5" x 3" x 1.9"

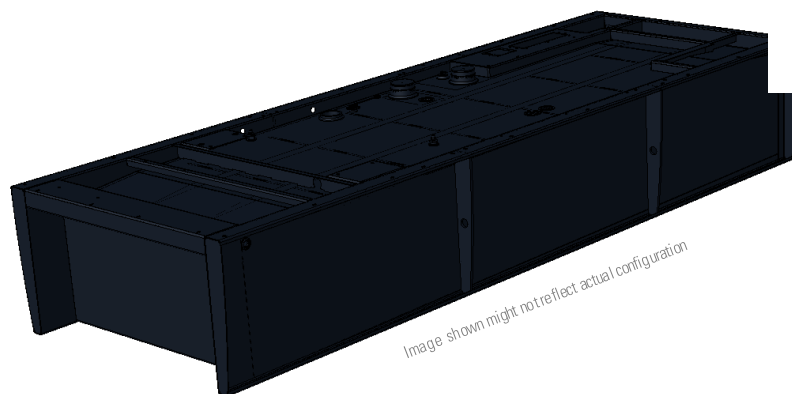

INTEGRAL FUEL TANKS D250 GC – D600 GC

FEATURES

- UL Listed for United States (UL 142) and Canada (CAN/ULC S601)
- Facilitates compliance with NFPA 30 code, NFPA 37 and 110 standards and CSA C282 code
- Dual wall
- Low fuel level warning standard, customer configurable warning or shutdown
- Primary tank leak detection switch in containment basin
- Tank design provides capacity for thermal expansion of fuel
- Fuel supply dip tube is positioned so as not to pick up fuel sediment
- Fuel return and supply dip tube is separated by an internal baffle to prevent immediate re-supply of heated return fuel
- Pressure washed with an iron phosphate solution
- Interior tank surfaces coated with a solvent-based thin-film rust preventative
- Heavy gauge steel gussets with internal lifting rings
- Primary and secondary tanks are leak tested at 20.7 kPa (3 psi) minimum
- Compatible with open packages and enclosures
- Gloss black polyester alkyd enamel exterior paint
- Welded steel containment basin (minimum of 110% of primary tank capacity)
- Direct reading fuel gauge with variable electrical output
- Emergency vents on primary and secondary tanks are sized in accordance with NFPA 30.

INTEGRAL

- Integral diesel fuel tank is incorporated into the generator set base frame
- Robust base design includes linear vibration isolators between tank base and engine generator.

OPTIONS

- Audio/visual fuel level alarm panel
- 5gal (18.9 L) spill containment*
- Locking Fuel Fill
- Overfill prevention Valve*

*Applicable for D350GC-D600GC Models only

Integral Fuel Tank Base Useable Capacities with Fuel Tank Dimensions & Weights

Standby kW	Width mm	Width in
250-300	1430	56.3
350-400	1630	64.1
450-500	1630	64.1
550-600	1865	73.4

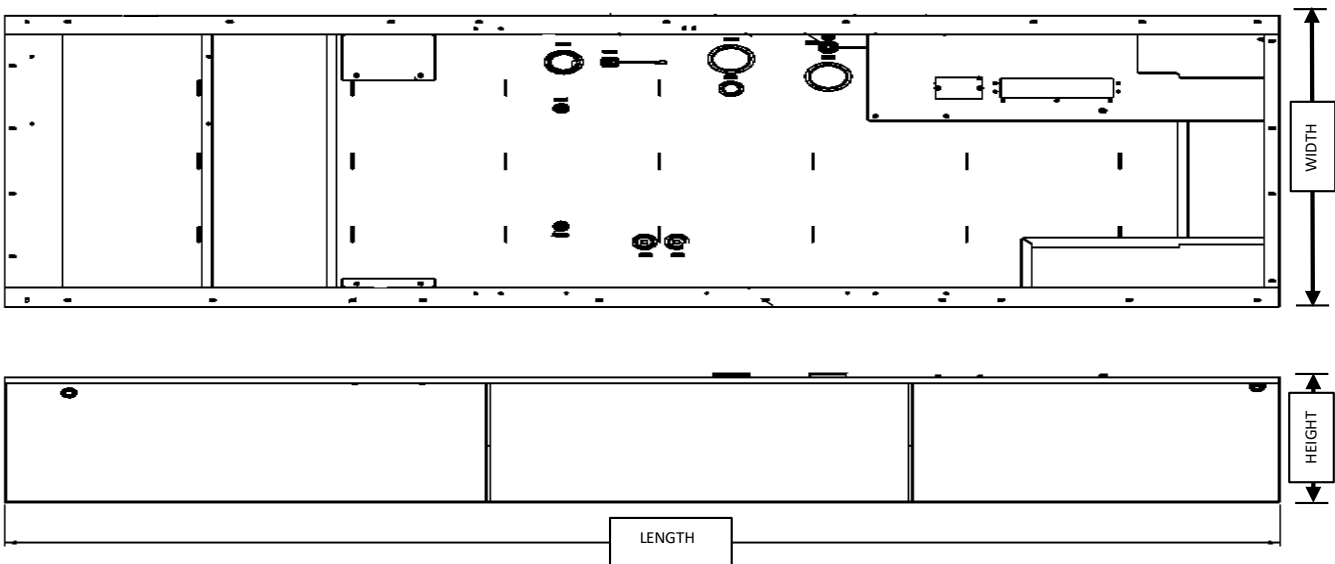

The heights listed above do not include lumber used during manufacturing and shipping

A. Open Set & Sound Attenuated Enclosure

Tank Design	Feature Code	Total Capacity		Useable Capacity		Tank Only						Overall Package Height with Tank			
		Litre	Gallon	Litre	Gallon	Dry Weight		Height 'H'		Length 'L'		Open		Enclosure	
						kg	lb	mm	in	mm	in	mm	in	mm	in
Integral Tank	FTDW035	2270.7	599.8	2059.9	543.9	970	2138	762.4	30.0	3958	155.8	2202	86.7	2487	97.9
	FTDW036	2820	744.9	2553	674.4	1165	2568	818.8	32.2	4815	189.5	2584	101.7	2644	104
	FTDW037	3671	969.7	3323	877.8	1331	2934	668.2	26.3	4622	181.9	2456	96.7	2644	104
	FTDW038	4292	1133.8	3889	1027.3	1657	3653	816.4	32.1	4980	196	2560	100.7	2721	107.1

B. Estimated Run Time (Hours)

Tank Design	Feature Code	Standby Ratings (kVA)						
		ekW	100%		75%		50%	
			Hrs	L/hr	Hrs	L/hr	Hrs	L/hr
Integral Tank	FTDW035	250	28.1	73.3	35	58.8	47	43.8
		300	24	86.0	30.8	66.8	40	51.5
	FTDW036	350	27.1	94.3	31.2	81.9	42.4	60.2
		400	24.1	105.9	28.1	90.7	38.6	66.2
	FTDW037	450	25.2	131.7	31.3	106.1	42.0	79.1
		500	24.3	137	30.1	110.5	46.6	71.3
	FTDW038	550	25.7	151.1	32.9	118.1	45.2	86.1
		600	24.1	161.6	30.0	129.6	42.4	91.7

Tanks with full electrical stub-up area include removable end channel. Tanks with RH stub-up include stubup area directly below the circuit breaker or power terminal strips.

Fuel tanks and applicable options facilitate compliance with the following United States NFPA Code and Standards:

NFPA 30: Flammable and Combustible Liquids Code

NFPA 37: Standard for the Installation and Use of Stationary Combustion Engines and Gas Turbines

NFPA 110: Standard for Emergency and Standby Power Systems

Fuel tanks and applicable options facilitate compliance with the following Canadian Standard and Code:

CSA C282 – Emergency Electrical Power Supply for Buildings

CSA B139-09 – Installation Code for Oil-Burning Equipment

SOUND ATTENUATED LEVEL 2

ENCLOSURES

D250GC – D600GC

60 Hz



Image shown might not reflect actual configuration

FEATURES

Robust / Highly Corrosion Resistant Construction

- Factory installed on skid base or tanks base
- Environmentally friendly, polyester powder baked paint
- Enclosure constructed with 18-gauge steel
- Interior zinc plated fasteners
- Internally mounted exhaust silencing system
- Comply with ASCE/SEI 7 for Wind loads up to 100mph
- Designed and tested to comply with UL 2200 Listed generator set package

Excellent Access

- Large cable entry area for installation ease.
- Accommodates side mounted single or multiple breakers.
- Two doors on both sides.
- Vertically hinged allow 180° opening rotation
- Radiator fill cover.

Security and Safety

- Lockable access doors which give full access to control panel and breaker.
- Cooling fan and battery charging alternator fully guarded.
- Fuel fill, oil fill and battery can only be reached via lockable access.
- Externally mounted emergency stop button (Optional).
- Designed for spreader bar lifting to ensure safety.
- Stub-up area is rodent proof.

Sound Attenuated Level 2

- Caterpillar white paint
- UL Listed integral fuel tank with 24 hours running time capacity (Optional).
- DC lighting package (Optional)

Enclosure Package Operating Characteristics

Enclosure Type	Standby ekW	Cooling Air Flow Rate		Ambient Capability*		Sound Pressure Levels (dBA) at 7m (23 ft)
		m ³ /s	cfm	°C	°F	100% Load
	250	6.4	13561	57	135	74
	300	6.4	13561	51	125	74
	350	7.4	15680	57	134	71
Level 2 Sound Attenuated Enclosure (Steel)	400	7.4	15680	53	127	71
	450	8.4	17692	54	130	73
	500	8.4	17692	50	122	73
	550	11.2	23731	56	133	73
	600	11.2	23731	53	127	73

*Cooling system performance at sea level. Consult your Cat[®] dealer for site specific ambient and altitude capabilities.

Note: Sound level measurements are subject to instrumentation, installation and manufacturing variability, as well as ambient site conditions.

DIMENSIONS

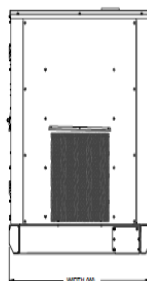
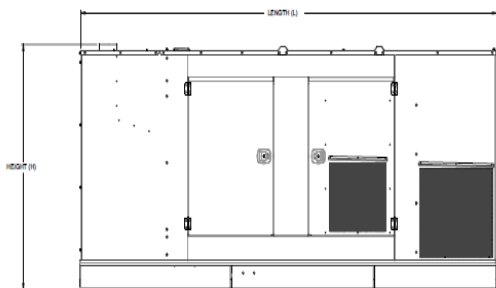

Sound Attenuated Enclosure on Skid Base

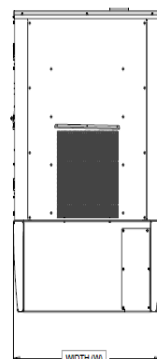
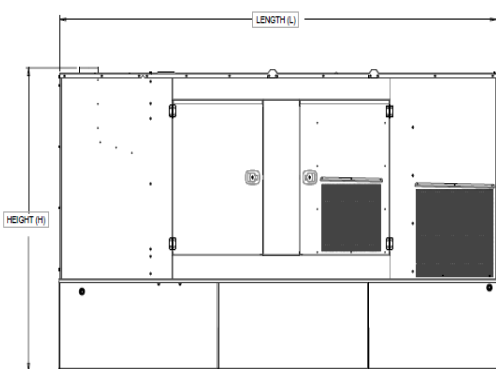

Sound Attenuated Enclosure on a UL Listed Integral Fuel Tank Base

Image shown might not reflect actual configuration

WEIGHTS & DIMENSIONS

Enclosure Type	Standby Ratings, ekW	Length, L		Width, W		Height, H		Package Weights	
		mm	in	mm	in	mm	in	kg	lb
Sound Attenuated Enclosure on Skid Base	250	3958	155.8	1440	56.7	1991	78.4	2857	6298.6
	300							2945	6492.6
	350	4633	182.4	1630	64.2	2227	87.7	3983	8781.0
	400							4017	8856.0
	450	4823	189.8	1630	64.2	2777	109.3	4408	9718.0
	500							4457	9826.0
	550	4980	196.1	1865	73.4	2723	107.2	4754	10480.8
	600							4837	10663.8
Sound Attenuated Enclosure on UL Listed Integral Fuel Tank Base	250	3958	155.8	1440	56.7	2487	97.9	3497	7709.6
	300							3585	7903.6
	350	4633	182.4	1630	64.2	2644	104.1	4765	10505.0
	400							4799	10580.0
	450	4823	189.8	1630	64.2	2777	109.3	5345	11783.7
	500							5394	11891.7
	550	4980	196.1	1865	73.4	2723	107.2	5973	13168.2
	600							6056	13351.2

LET'S DO THE WORK.™

LEHE2014-02 (09-19)

www.Cat.com/electricpower

©2019 Caterpillar All rights reserved. Materials and specifications are subject to change without notice. The International System of Units (SI) is used in this publication. CAT, CATERPILLAR, their respective logos, "Caterpillar Yellow", the "Power Edge" and Cat "Modern Hex" trade dress as well as corporate and product identity used herein, are trademarks of Caterpillar and may not be used without permission.

CONTROL SCHEMATIC (DSE 6310)

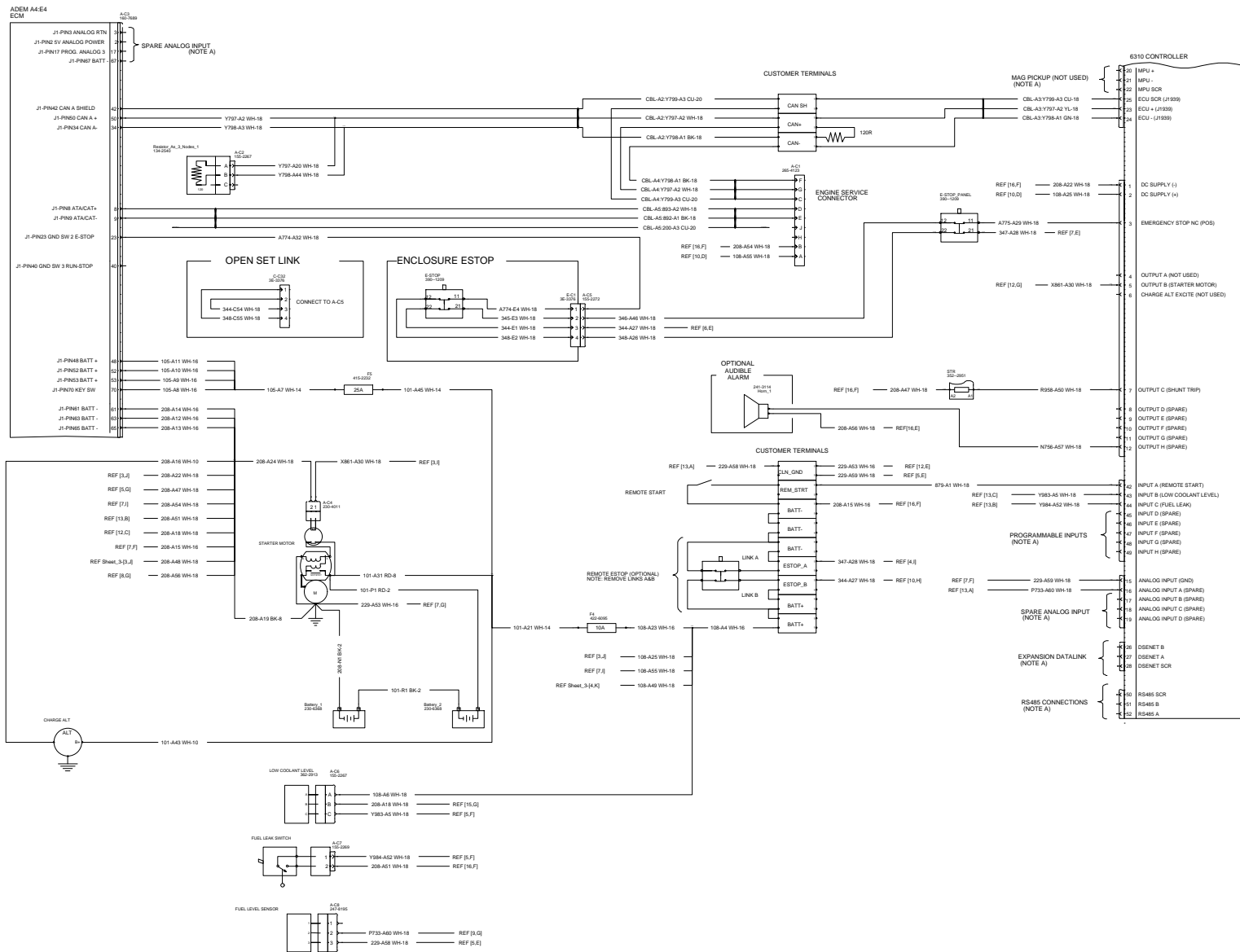

Terminal	Wire	Function
1	108-A43 WH-10	CHARGE ALT
2	108-A43 WH-10	CHARGE ALT
3	108-A43 WH-10	CHARGE ALT
4	108-A43 WH-10	CHARGE ALT
5	108-A43 WH-10	CHARGE ALT
6	108-A43 WH-10	CHARGE ALT
7	108-A43 WH-10	CHARGE ALT
8	108-A43 WH-10	CHARGE ALT
9	108-A43 WH-10	CHARGE ALT
10	108-A43 WH-10	CHARGE ALT
11	108-A43 WH-10	CHARGE ALT
12	108-A43 WH-10	CHARGE ALT
13	108-A43 WH-10	CHARGE ALT
14	108-A43 WH-10	CHARGE ALT
15	108-A43 WH-10	CHARGE ALT
16	108-A43 WH-10	CHARGE ALT
17	108-A43 WH-10	CHARGE ALT
18	108-A43 WH-10	CHARGE ALT

POWER SCHEMATIC

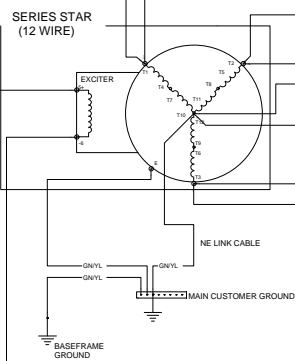
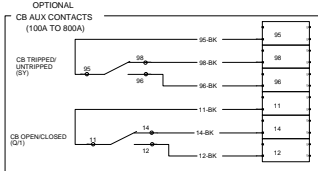
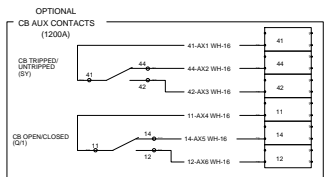
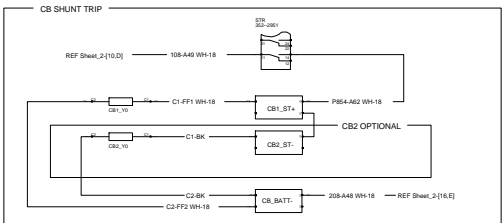
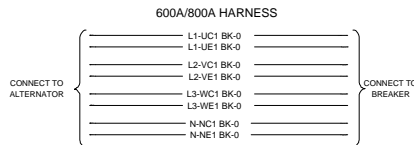
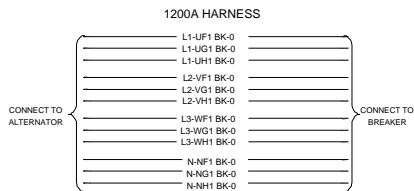
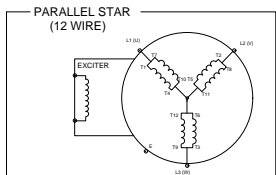
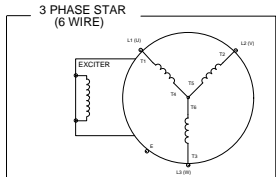

400A HARNESS

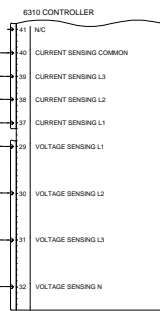
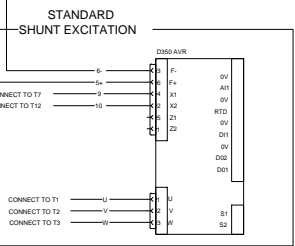
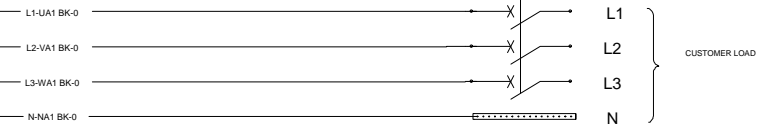

1	2	3	4	5	6	7	8	9	10	11	12	13	14	15	16	17	18	
19	20	21	22	23	24	25	26	27	28	29	30	31	32	33	34	35	36	37

ADDITIONAL INFORMATION - COMPONENT DETAILS & CUSTOMER CONNECTIONS

MAIN CUSTOMER RAIL (OPTIONS INCLUDED)

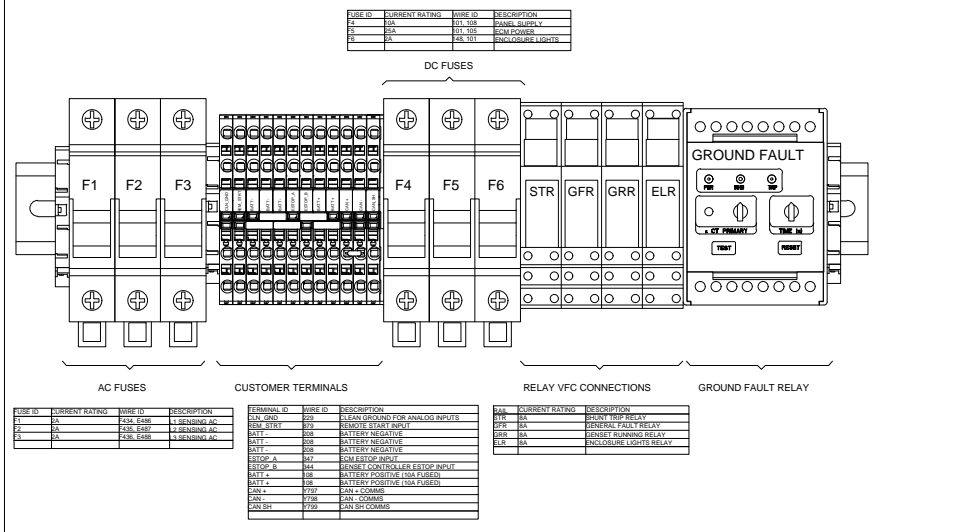

CIRCUIT BREAKER RAIL (OPTIONS INCLUDED)

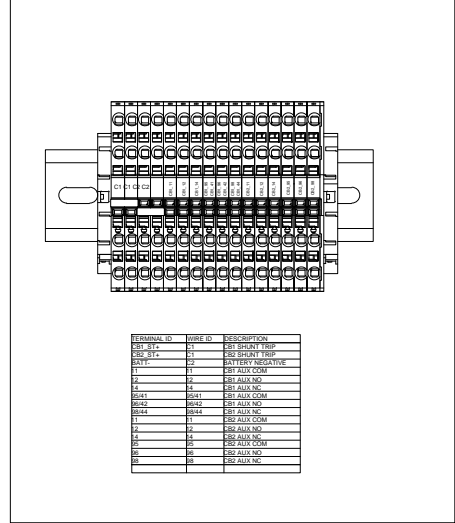

SHORE POWER RAIL (OPTIONS INCLUDED)

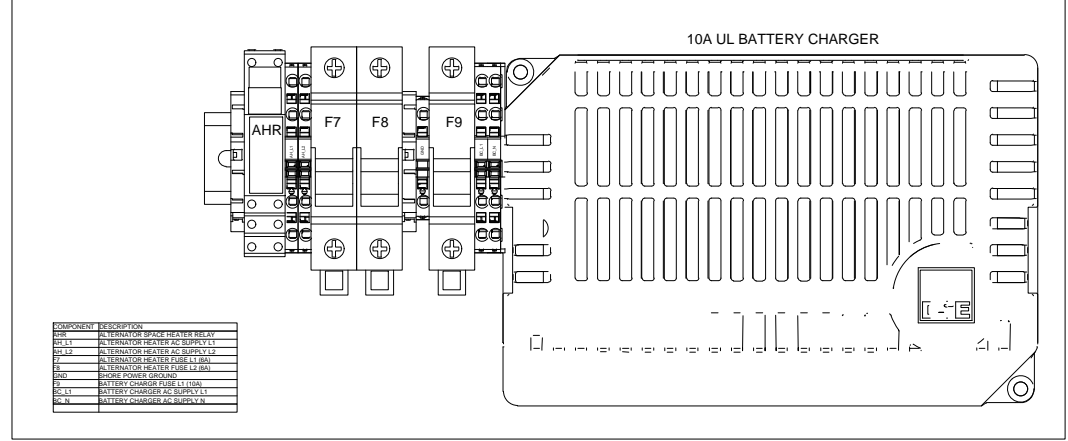

TERMINAL ID	DESCRIPTION
SEN_GND	SEN GROUND FOR ANALOG INPUTS
SEN_STRT	SENSE START INDUT
BATT+	BATTERY POSITIVE
BATT-	BATTERY NEGATIVE
STOP-	STOP NEGATIVE
STOP_A	STOP NEGATIVE INDUT
STOP_B	STOP NEGATIVE INDUT
BATT+	BATTERY POSITIVE 10A FUSED
BATT-	BATTERY POSITIVE 10A FUSED
PAN+	PAN POSITIVE
PAN_BH	PAN SH COMB

QTY	ENGINE CONNECTIONS	SIZE	SHEET
1	COOLANT DRAIN	ø19.05 [ø0.75] I.D.	2,3
1	OIL DRAIN	1-1/8-12 THD	2,3
1	EXHAUST	ø203.2 [ø8.00] O.D.	2
1	FUMES DISPOSAL HOSE	ø35.00 [ø1.38] I.D.	3

QTY	POSSIBLE TANK CONNECTIONS	SIZE	SHEET
1	FUEL SUPPLY	13/16-16 THD	3
1	FUEL RETURN	13/16-16 THD	3
2	SPARE PORTS	2" NPTF THD	3
1	FUEL FILL	4" NPT THD	3
1	MAIN TANK EMERGENCY VENT	4-8 NPTF THD	3
1	MAIN TANK NORMAL VENT	2" NPTF THD	2,3
1	BASIN TANK EMERGENCY VENT	4-8 NPT THD	3

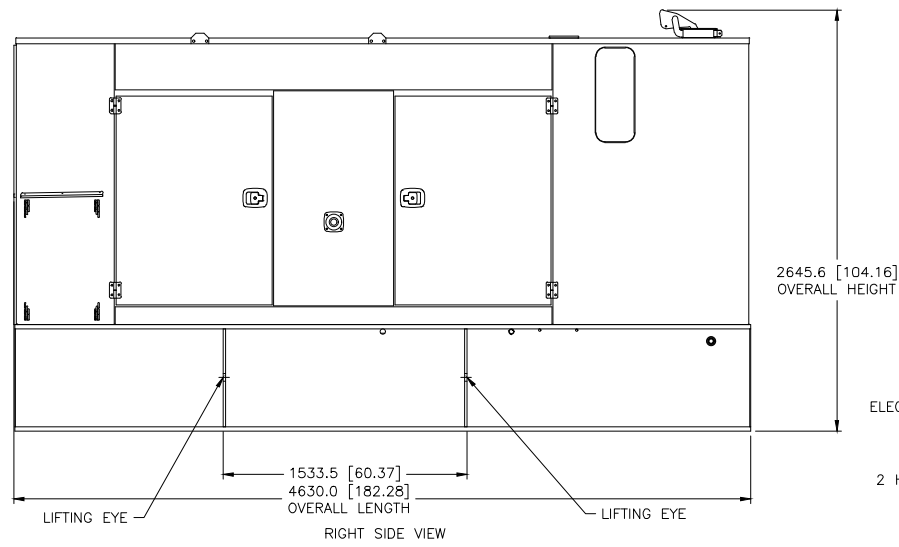

ELECTRICAL STUB-UP AREA
LIFTING EYE
ø50.0 [ø1.97]
2 HOLES EACH SIDE

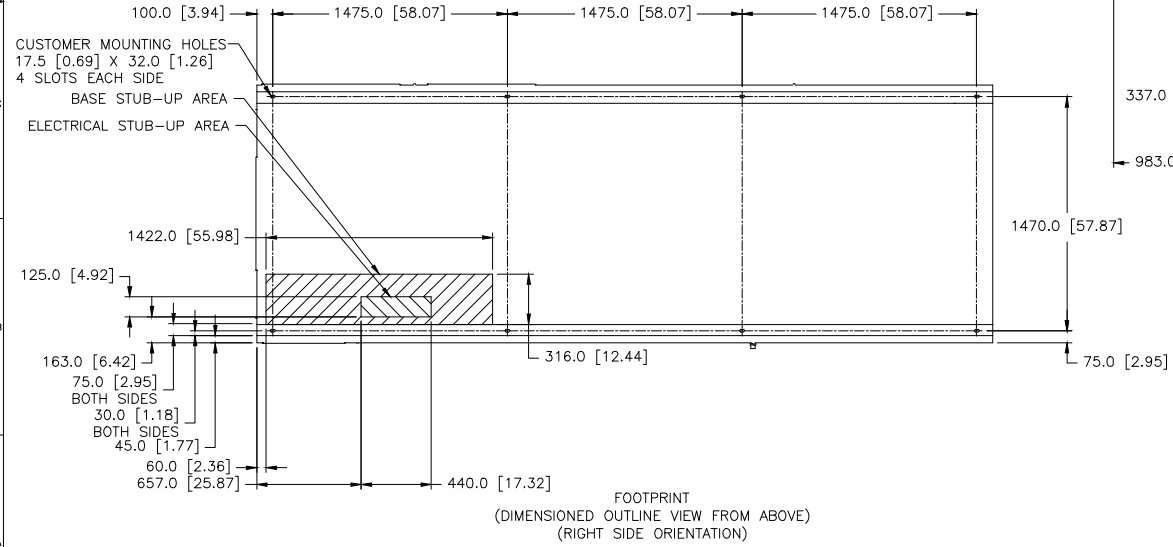
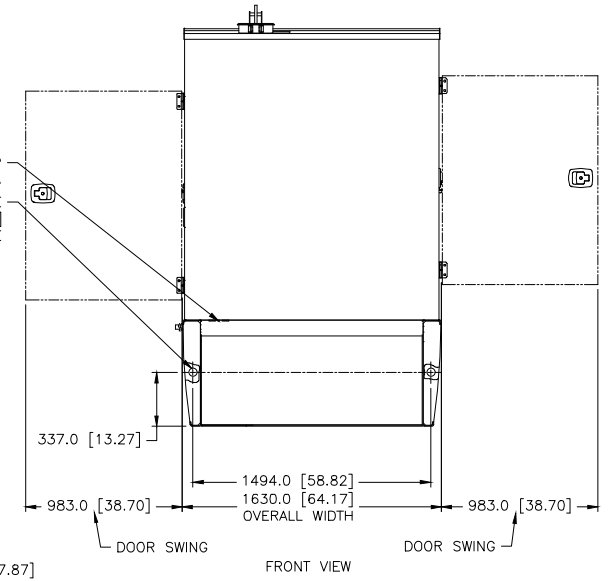

MODEL	TYPE	ENGINE AR	ENCLOSURE AR	TANK AR
C13	Y	LS-3973 CHG 00	LS-3858 CHG 00	LS-3870 CHG 00
		LS-3974 CHG 00		
		LS-3975 CHG 00		
		LS-3976 CHG 00		

PACKAGE LIFTED IN 4 PLACES
PACKAGE SHOWN WITH MORE DETAIL ON SHEETS 2 & 3

1:2
1:10
1:50
1:100
1:200
1:500
1:1000

1C2968BIDDEN
1E2735 DRAWING AUTO CAD
1E0188 BURN MARKINGS
1E00136 CONFIDENTIALITY
1E0124 IN OPERATION
1E0011 INTER & I/O

REV. NO. 1
BY: B. VILLENNA
CHK: B. VILLENNA
DATE: 12/10/19
APP: [Signature]

RECORDS 1X

DATE: 08/19/19
SHEET 1 OF 3

CATERPILLAR INC.

INSTALLATION COMPOSITE
C13 SA WZ INTEG 24HR TANK
588-8337

