

# Cat® D1000 GC

## Diesel Generator Sets



Image shown might not reflect actual configuration.

Engine	C32
Bore – mm (in)	145 (5.7)
Stroke – mm (in)	162 (6.4)
Displacement – L (in <sup>3</sup> )	32.1 (1959)
Compression Ratio	15.0:1
Aspiration	TA
Fuel System	EUI
Governor Type	ADEM™ A4

Model	Standby 60 Hz kW (kVA)	Emissions Performance
D1000 GC	1000 (1250)	U.S EPA Emergency Stationary Use only (Tier 2)

### Standard Features

#### Cat® Diesel Engine

- Meets U.S. EPA Emergency Stationary Use only (Tier 2) emission standards
- Reliable performance proven in thousands of applications worldwide

#### Generator Set Package

- Accepts 100% block load in one step and meets NFPA 110 loading requirements
- Conforms to ISO 8528-5 G3 load acceptance requirements
- Reliability is verified through prototype testing, which includes torsional vibration, fuel consumption, oil consumption, transient performance, and endurance testing

#### Alternators

- Superior motor starting capability minimizes the need for oversizing the generator
- Designed to match the performance and output characteristics of Cat diesel engines

#### Cooling System

- Cooling systems available to operate in ambient temperatures TBD (To be validated)
- Tested to ensure proper generator set cooling

#### GCCP Control Panels

- User-friendly set-up and button layout for ease of use
- Multiple parameters are monitored & displayed simultaneously for full visibility
- The module can be configured to suit a wide range of applications for user flexibility

#### Warranty and Extended Service Coverage (ESC)

- 24 months/1000-hour warranty for standby ratings
- 5 yrs Gold Complimentary Extended Service Coverage

#### Worldwide Product Support

- Cat dealers have over 1,800 dealer branch stores operating in 200 countries
- Your local Cat dealer provides extensive post-sale support, including maintenance and repair agreements

#### Financing

- Caterpillar offers an array of financial products to help you succeed through financial service excellence
- Options include loans, finance lease, operating lease, working capital, and revolving line of credit
- Contact your local Cat dealer for availability in your region

### Standard and Optional Equipment

#### Engine

##### Air Cleaner

- Single element
- Dual element

##### Starting

- Standard batteries
- Oversized batteries
- Dual Electric Starters
- Jacket water heater

##### Engine Attachments

- 6" Exhaust Flexible Fittings
- 6" Exhaust Flange Kits
- Radiator Duct Flange

#### Alternator

##### Output voltage

- 480V
- 600V

##### Temperature Rise (over 40°C ambient)

- 125°C
- 105°C

##### Winding type

- Random wound

##### Excitation

- Internal excitation (IE)
- Permanent magnet (PM)

##### Attachments

- Anti-condensation heater

#### Power Termination

##### Type

- Circuit breaker (Primary)
- 1200A  1600A  2000A
- Circuit breaker (Auxiliary)
- 250A  400A
- 3-pole
- Manually operated

##### Trip Unit

- LSI  LSIG  LSIG-P

#### Factory Enclosure

- Sound attenuated
- Weatherproof

##### Attachments

- DC lighting package

#### Fuel Tank

- Intergrated 2100 gal (7950 L)
- Sub base 3000 gal (11356 L)
- Sub base 4200 gal (15876 L)

#### Control System

##### Controller

- GCCP 1.2

##### Attachments

- Remote annunciator module
- Expansion I/O module
- 100A Load Center
- 20A GFCI AC Receptacle
- Ground Fault Indication
- Audible Alarm

#### Charging

- Battery charger – 10A (Installed)
- Battery charger – 20A  
(Shipped loose)

#### Cat Connect

##### Connectivity

- Ethernet
- Cellular

#### Extended Service Options

##### Terms

- 3 year
- 4 year
- 5 year

##### Coverage

- Silver
- Gold

#### Certifications

- UL 2200 Listed
- cUL CSA 22.2 No. 100-14
- IBC seismic certification

Note: Some options may not be available on all models. Certifications may not be available with all model configurations. Consult factory for availability.

### Package Performance – D1000 GC

Performance	Standby	
Frequency	60 Hz	
Gen set power rating with fan	1000 ekW	
Gen set power rating with fan @ 0.8 power factor	1250 kVA	
Fueling strategy	EPA ESE (Tier 2)	
Performance number	DM9933	
<b>Fuel Consumption</b>		
100% load with fan – L/hr (gal/hr)	272.1	(71.9)
75% load with fan – L/hr (gal/hr)	213.4	(56.4)
50% load with fan – L/hr (gal/hr)	144.7	(38.2)
25% load with fan – L/hr (gal/hr)	82.6	(21.8)
<b>Cooling System</b>		
Radiator air flow restriction (system) – kPa (in. water)	0.12	(0.48)
Radiator air flow – m <sup>3</sup> /min (cfm)	943	(33301)
Engine coolant capacity – L (gal)	55	(14.5)
Radiator coolant capacity – L (gal)	49	(12.9)
Total coolant capacity – L (gal)	104	(27.5)
<b>Inlet Air</b>		
Combustion air inlet flow rate – m <sup>3</sup> /min (cfm)	87.6	(3094.1)
<b>Exhaust System</b>		
Exhaust stack gas temperature – °C (°F)	476.4	(889.5)
Exhaust gas flow rate – m <sup>3</sup> /min (cfm)	228.4	(8065.3)
Exhaust system backpressure (maximum allowable) – kPa (in. water)	6.7	(27.0)
<b>Heat Rejection</b>		
Heat rejection to jacket water – kW (Btu/min)	352	(20033)
Heat rejection to exhaust (total) – kW (Btu/min)	1024	(58206)
Heat rejection to aftercooler – kW (Btu/min)	288	(16385)
Heat rejection to atmosphere from engine – kW (Btu/min)	127	(7238)
Heat rejection from alternator – kW (Btu/min)	55	(3131)
<b>Emissions* (Nominal)</b>		
NOx mg/Nm <sup>3</sup> (g/hp-h)	2348.6	(4.93)
CO mg/Nm <sup>3</sup> (g/hp-h)	62.1	(0.13)
HC mg/Nm <sup>3</sup> (g/hp-h)	5.5	(0.01)
PM mg/Nm <sup>3</sup> (g/hp-h)	7.2	(0.02)
<b>Emissions* (Potential Site Variation)</b>		
NOx mg/Nm <sup>3</sup> (g/hp-h)	2841.6	(5.97)
CO mg/Nm <sup>3</sup> (g/hp-h)	116.1	(0.24)
HC mg/Nm <sup>3</sup> (g/hp-h)	10.3	(0.03)
PM mg/Nm <sup>3</sup> (g/hp-h)	14.1	(0.04)

\*mg/Nm<sup>3</sup> levels are corrected to 5% O<sub>2</sub>. Contact your local Cat dealer for further information.

# D1000 GC Diesel Generator Sets

## Electric Power



### Weights and Dimensions

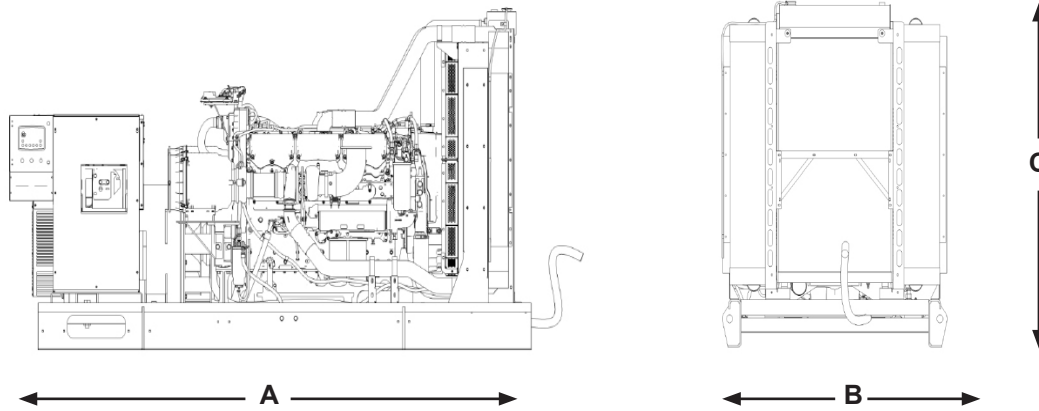

Model	Dim "A" mm (in)	Dim "B" mm (in)	Dim "C" mm (in)	Dry Weight kg (lb)
D1000 GC	4175 (164.3)	1856 (73.1)	2217.5 (87.3)	6654 (14669)

**Note:** For reference only. Do not use for installation design. Contact your local Cat dealer for precise weights and dimensions.

### Ratings and Definitions

#### Standby

Output available with varying load for the duration of the interruption of the normal source power. Average power output is 70% of the standby power rating. Typical operation is 200 hours per year, with maximum expected usage of 500 hours per year.

#### Applicable Codes and Standards

CSA C22.2 No. 100-14, UL 142, UL 489, UL 869A, UL 2200, IBC 2018, ISO 3046, ISO 8528 and facilitates compliance to NFPA37, NFPA70, NFPA99 and NFPA110 codes

**Note:** Codes may not be available in all model configurations. Please consult your local Cat dealer for availability.

#### Fuel Rates

Fuel rates are based on fuel oil of 35° API [16°C (60°F)] gravity having an LHV of 42,780 kJ/kg (18,390 Btu/lb) when used at 29°C (85°F) and weighing 838.9 g/liter (7.001 lbs/U.S. gal.).

[www.cat.com/electricpower](http://www.cat.com/electricpower)

©2022 Caterpillar  
All rights reserved.

Materials and specifications are subject to change without notice.

**LET'S DO THE WORK.™**

The International System of Units (SI) is used in this publication. CAT, CATERPILLAR, LET'S DO THE WORK, their respective logos, "Caterpillar Corporate Yellow", the "Power Edge" and Cat "Modern Hex" trade dress as well as corporate and product identity used herein, are trademarks of Caterpillar and may not be used without permission.



Image shown might not reflect actual configuration

## GCCP 1.2 - Control Panel

GCCP 1.2 is an auto Start Control Module suitable for a wide variety of diesel gen-set applications. Monitoring an extensive number of engine parameters, the modules will display warnings, shutdown and engine status information on the backlit LCD screen, illuminated LEDs and remote PC.

### FEATURES

- 4-line back-lit LCD text display
- Multiple display languages
- Five-key menu navigation
- LCD alarm indication
- Customisable power-up text and images
- Data logging facility
- Internal PLC editor
- Protections disable feature
- Fully configurable via PC using USB & RS485 communication
- Front panel configuration with PIN protection
- Power save mode
- 3-phase generator sensing and protection
- Generator current and power monitoring (kW, kvar, kVA, pf)
- kW and kvar overload and reverse power alarms
- Over current protection
- Unbalanced load protection
- Breaker control via fascia buttons
- Fuel and start outputs configurable when using CAN Support for 0 V to 10 V & 4 mA to 20 mA sensors
- 8 configurable digital inputs (3 available for Customer use)
- 8 configurable digital outputs (5 available for Customer use)
- 4 configurable analogue inputs (3 available for Customer Use)
- CAN, MPU and alternator frequency speed sensing in one variant
- Real time clock
- Engine pre-heat and post-heat functions
- Engine run-time scheduler
- Engine idle control for starting & stopping
- Fuel usage monitor and low fuel level alarms
- 3 configurable maintenance alarms

### BENEFITS

- Hours counter provides accurate information for monitoring and maintenance periods
- User-friendly set-up and button layout for ease of use
- Multiple parameters are monitored & displayed simultaneously for full visibility
- The module can be configured to suit a wide range of applications for user flexibility
- PLC editor allows user configurable functions to meet user specific application requirements.
- RS485 Communication port can be used for the Remote Monitoring Communication (Compatible with Cat PLG)

### SPECIFICATION

#### DC SUPPLY

##### CONTINUOUS VOLTAGE RATING

8 V to 35 V Continuous  
5 V for upto 1 minute

#### CRANKING DROPOUTS

Able to survive 0 V for 100 ms, providing supply was at least 10 V before dropout and supply recovers to 5 V. This is achieved without the need for internal batteries.

LEDs and backlight will not be maintained during cranking.

#### MAXIMUM OPERATING CURRENT

260 mA at 12 V, 150 mA at 24 V

#### MAXIMUM STANDBY CURRENT

145 mA at 12 V, 85 mA at 24 V

#### CHARGE FAIL/EXCITATION RANGE

0 V to 35 V

#### GENERATOR & MAINS (UTILITY) VOLTAGE RANGE

15 V to 415 V AC (Ph to N)  
26 V to 719 V AC (Ph to Ph)

#### FREQUENCY RANGE

3.5 Hz to 75 Hz

#### MAGNETIC PICKUP VOLTAGE RANGE

+/- 0.5 V to 70 V

#### FREQUENCY RANGE

10,000 Hz (max)

#### INPUTS

##### DIGITAL INPUTS A TO H

Negative switching

##### ANALOGUE INPUTS A & D

Configurable as:

Negative switching digital input 0 V to 10 V sensor  
4 mA to 20 mA sensor Resistive sensor

##### ANALOGUE INPUTS B & C

Configurable as:

Negative switching digital input Resistive sensor

#### OUTPUTS

##### OUTPUT A & B (FUEL & START)

15 A DC at supply voltage

##### AUXILIARY OUTPUTS C, D, E, F, G & H

2 A DC at supply voltage

#### DIMENSIONS OVERALL

216 mm x 158 mm x 43 mm  
8.5" x 6.2" x 1.5"

#### PANEL CUT-OUT

184 mm x 137 mm  
7.2" x 5.3"

#### MAXIMUM PANEL THICKNESS

8 mm  
0.3"

#### STORAGE TEMPERATURE RANGE

-40°C to +85°C  
-40 °F to +185 °F

#### OPERATING TEMPERATURE RANGE

-30°C to +70°C  
-22 °F to +158 °F

LEHE2017-02 (09-20)

[www.Cat.com/electricpower](http://www.Cat.com/electricpower)

©2020 Caterpillar All rights reserved. Materials and specifications are subject to change without notice. The International System of Units (SI) is used in this publication. CAT, CATERPILLAR, their respective logos, "Caterpillar Corporate Yellow", the "Power Edge" and Cat "Modern Hex" trade dress as well as corporate and product identity used herein, are trademarks of Caterpillar and may not be used without permission.

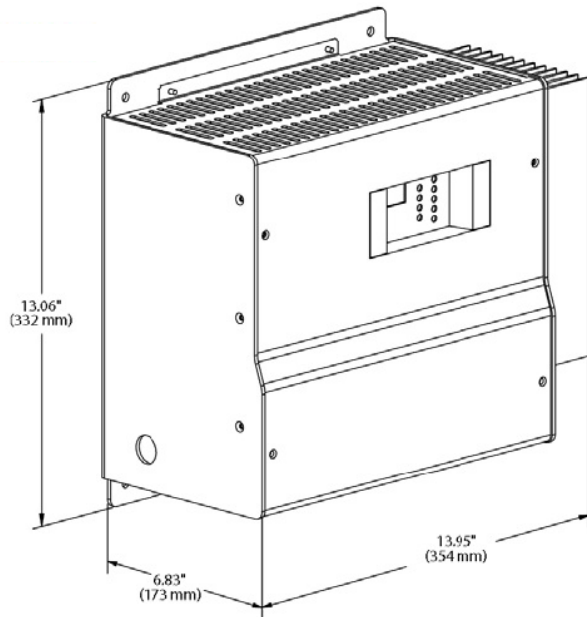

## UL 20 Amp Battery Charger

This battery charger offers accurate, automatic charging of lead-acid and nickel cadmium batteries. The output voltage automatically adjusts to changing input, load, battery and ambient conditions. This prevents battery over-charging and consequent loss of battery electrolyte.

Standard features include AC line compensation, precision voltage regulation, current limiting, automatic 2-rate charging, voltmeter and ammeter, temperature compensation and UL Listing.

The user interface is easy to understand with digital metering, NFPA 110 alarms and a battery fault alarm.

### Features

- Electronically current limited at 105% of rated output
- Alarm system
- Digital Display
- Lightning and voltage transient protection
- Protection of connected equipment against load dump
- Constant voltage, current limited, 4-rate automatic equalization
- IP 20 housing
- Temperature Compensation
  - On board temperature sensor with remote port
- AC isolated from DC
- Auto AC line compensation
- Output regulated by sensed battery voltage

Dimensions			
Width	Depth	Height	Weight
354 mm (13.93 in)	173 mm (6.83 in)	332 mm (13.06 in)	19.1 kg (42 lb)

Feature code: BTC 20A2

### Specification

Input supply	110 – 120 V 208 – 240V
AC and DC fuses	(2 input and 2 output)
Output voltage	24V
Output amps	20A
Input Frequency	50 / 60 Hz
Operating temperature	–20°C (–4°F) to +60°C (140°F)

Housing constructed of rustproof anodized aluminum.

### Standards

- C-UL listed to UL 1236
- NFPA 70, NFPA 110
- CSA 22.2 No 107 certified
- UL 1564
- CE DOC to EN 60335
- IBC Seismic Certification

## NFPA 110 alarm package as follows:

- AC on Green led (indication)
- AC fail Red led and form C contact (2A)
- Float mode LED
- Fast charge LED
- Temp comp active LED
- Low battery volts Red LED and Form C contact
- High battery volts Red LED and Form C contact
- Charger fail Red LED and Form C contact
- Battery fault Red LED and Form C contact
  - Battery disconnected
  - Battery polarity reversed
  - Mismatched charger battery voltage
  - Open or high resistance charger to battery connection
  - Open battery cell or excessive internal resistance

Information contained in this publication may be considered confidential. Discretion is recommended when distributing.  
Materials and specifications are subject to change without notice.

CAT, CATERPILLAR, LET'S DO THE WORK, their respective logos, "Caterpillar Yellow," the "Power Edge" and Cat "Modern Hex" trade dress as well as corporate and product identity used herein, are trademarks of Caterpillar and may not be used without permission.



Image shown may not reflect actual configuration.

## 20A Tamper-Resistant, Weather-Resistant GFCI Receptacles

### Features and Benefits

- Automatically tests the GFCI every time the reset button is pushed in. The GFCI will not reset if the GFCI circuit is not functioning properly.
- By blocking reset of the GFCI if protection has been compromised, SmartLockPRO reduces the possibility of end-users incorrectly assuming that a reset GFCI outlet is providing ground fault protection when it actually is not.
- A line-load reversal diagnostic feature is provided which prevents the GFCI from being reset and stops power from being fed to the GFCI receptacle face or through to downstream devices. A green LED indicator on the GFCI's face also illuminates to alert the installer to the line-load wiring reversal.

### Weather-Resistant GFCIs

- Meet UL 498 requirements for weather-resistant receptacles.

### Tamper-Resistant GFCIs

- Shutter mechanism inside the receptacle blocks access to the contacts unless a two-prong plug is inserted, helping ensure foreign objects will be locked out.

### Product Features

- Grounding: GFCI ground fault
- Feature: Weather and tamper-resistant
- Amperage: 20 Amp
- Voltage: 125 Volt
- NEMA: 5-20R
- Trip Level: Class A, 5mA plus or minus 1mA
- Pole: 2
- Wire: 3
- Color: White

### Standards and Certifications

- NEMA: WD-6
- ANSI: C-73
- UL498: File E13399
- CSA C22.2 No. 42: File LR-57811
- NOM: 057
- UL 943: File E48380

Receptacles contained in a weather resistant box and in-use cover.



[www.Cat-ElectricPower.com](http://www.Cat-ElectricPower.com)

©2016 Caterpillar  
All rights reserved.

Materials and specifications are subject to change without notice.

CAT, CATERPILLAR, their respective logos, "Caterpillar Yellow", the "Power Edge" trade dress as well as corporate and product identity used herein, are trademarks of Caterpillar and may not be used without permission.



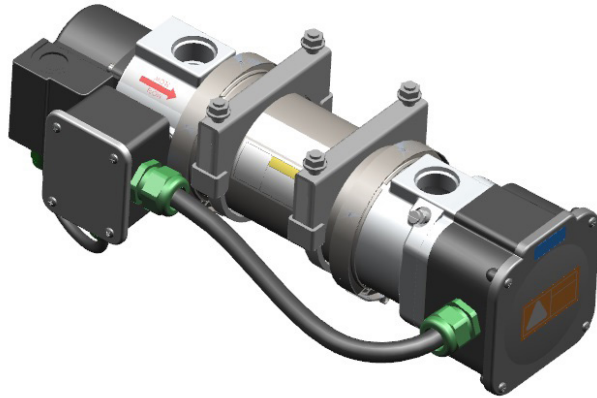

## Features

### Factory Installed

- Complete with Hoses, Thermostat (Control and Hi-Limit) and Pump
- Base Frame mounting minimizes Engine induced vibration
- Temperature Controlled Pump operation
- Supplied with UL, C (UL) US and CE recognized components
- Control Thermostat is Factory preset to 49°C (120°F)

### Heater Design Description

- Jacket Water Heater Package is designed to efficiently preheat the engine by circulating the heated coolant onto engine
- This design results in following benefits
- Increase life of Heater Hoses, Engine Seals and Heating Elements
- Improves Heat Transfer efficiency from Elements to Engine Coolant
- Uniform Engine temperature distribution
- Application of Thermostat with a reduced thermal differential
- Lower Customer utility costs and increased Heater reliability
- Heater's Control Thermostat set point is preset

## Jacket Water Heater with Pump Diesel Gensets: C27, C32

Caterpillar offers a factory installed Jacket Water Heater for improved Engine Cold-Starting capability

This Jacket Water Heater is a Thermostatically controlled Heater with an integrated pump, built in bleed screw and High Limit Thermostat that can be manually reset

Forced circulation of the coolant delivers uniform heating throughout the entire engine, reduces wear from Cold spots and offers significant reduction of Electrical consumption

### Heater Operation

A 34 L/pm (9 GPM) Pump is located at the Heater Inlet to push the coolant through the Heater  
A Control Thermostat is located inside a Plastic Enclosure near the Inlet of Heater and responds to the temperature of coolant entering the tank  
A High Limit Thermostat is located inside a Plastic Element Enclosure near the Outlet of Heater opens and cuts off supply to Heating Element, if tank attains 96°C (205°F). This Thermostat can be manual reset to close position.

Temperature Controlled Pump Operation – Pump runs only with Heating Elements.

Air release valve (Bleed Screw) provided to allow vent air from Heater, prior to energizing the Heater.

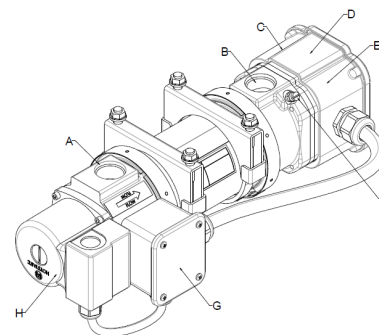

- |  |   |
|--|---|
| <b>A.</b> Suction Port (SAE Dash 16)   | <b>E.</b> High-limit Thermostat with manual reset (in Element assembly) |
| <b>B.</b> Discharge Port (SAE Dash 16) | <b>F.</b> Air Release Valve   |
| <b>C.</b> Power in Wiring Entrance     | <b>G.</b> Control Thermostat (in enclosure)                             |
| <b>D.</b> Element Assembly             | <b>H.</b> Pump/Motor  |

## Specifications

	Voltage	
	240	220
Heater Power	6kW	6kW
Frequency	60	50
Phase	Single	Single
Amps	25A	26A
Flow Rate	34 L/pm (9 GPM)	
Pump Rating	230 VAC 97W	230 VAC 70W
Control Thermostat (Set Point)	38°C – 49°C (100°F – 120°F)	
High Limit Thermostat (Set Point)	96°C (205°F), Manual Reset	
Length	466 mm (18.3")	
Width	216 mm (8.5")	
Height	183 mm (7.2")	
Weight	6.5 Kg	

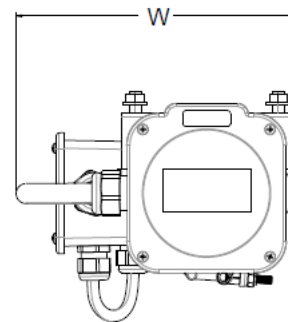
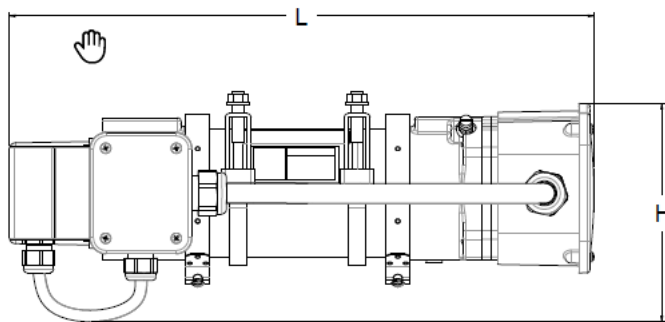

## Wiring Diagram

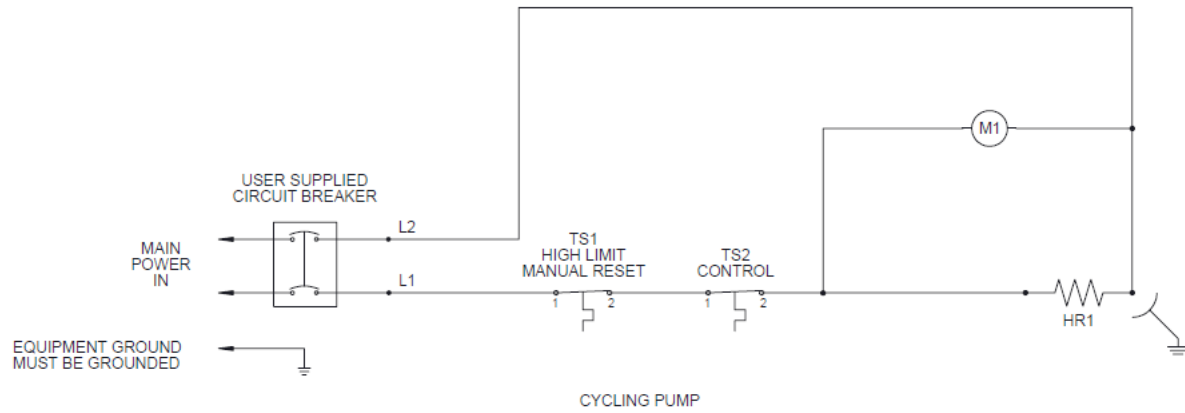

Materials and specifications are subject to change without notice. The International System of Units (SI) is used in this publication.  
© 2021 Caterpillar. All Rights Reserved. CAT, CATERPILLAR, LET'S DO THE WORK, their respective logos, "Caterpillar Corporate Yellow", the "Power Edge" and Cat "Modern Hex" trade dress as well as corporate and product identity used herein, are trademarks of Caterpillar and may not be used without permission



## ADEM™ A4 Engine Controller

The ADEM™ A4 is the main Electronic Control Module (ECM) used on select diesel engines. The ADEM A4 provides a higher degree of control over a large number of combustion variables. The ADEM A4 is designed to control/interface Electronic Unit Injector (EUI) equipped engines. The ADEM A4 engine system is composed of the ADEM A4 ECM, control software, sensors, actuators, fuel injectors, and interface to the generator system. The prime benefit of an ADEM A4 engine system is to better control and maintain the particulate emissions, both steady state and transient, while improving engine performance.

## Features

### Reliable, Durable

All ADEM A4 controllers are designed to survive the harshest environments.

- Environmentally sealed, die-cast aluminum housing isolates and protects electronic components from moisture and dirt contamination
- Rigorous vibration testing ensures product reliability and durability
- Accuracy maintained from  $-40^{\circ}\text{C}$  to  $85^{\circ}\text{C}$
- Electrical noise immunity to 100 volts / meter
- Internal circuits are designed to withstand shorts to + battery and – battery

### Simple Servicing

Each ADEM A4 system works in combination with the Cat® ET service tool software to keep the engine operating at peak performance.

- Displays measured parameters
- Retrieves active and logged event code documenting abnormal system operation
- Performs calibrations and diagnostic tests
- Supports flash programming of new software into the ADEM A4 ECM

### Self Diagnostics

Each ADEM A4 ECM has a full compliment of diagnostics. The ECM can detect faults in the electrical system and report those faults to the service technician for quick repair.

- Self-diagnostic capability pinpoints operational problems in need of attention.

### Advanced Features

- Enhanced performance from fuel injection timing and limiting
- Adjustable monitoring of vital engine parameters
- Programmable speed acceleration ramp rate
- Data link interfaces

## Description

The ECM is housed in an environmentally sealed cast-ing. All wiring connections to the ECM are made using two sealed connectors: a single seventy-pin connector and a single one hundred twenty-pin connector.

## Engine Speed Governing

Desired engine speed is calculated by the ECM and held within  $\pm 0.2$  Hz for isochronous and droop mode. The ECM accounts for droop that is requested. The proper amount of fuel is sent to the injectors due to these calculations. The ECM also employs cooldown/shutdown strategies, acceleration delays on startup, acceleration ramp times and speed reference.

## Fuel Limiting

Warm and cold fuel-air ratio control limits are controlled by the ECM. Electronic monitoring system derates, torque limit, and cranking limit, programmable torque scaling, and cold cylinder cutout mode are standard features.

## Fuel Injection Timing

Master timing for injection is controlled by the ECM control. Temperature dependencies are accounted for in the fuel injection calculations.

## Electronic Monitoring

Electronic monitoring of vital engine parameters can be programmed. Warning, derate, and shutdown event conditions may be customized by the user.

## Information Management

The ECM stores information to assist with electronic troubleshooting. Active and logged diagnostic codes, active events, logged events, fuel consumption, engine hours, and instantaneous totals aid service technicians when diagnosing electronic faults and scheduling preventive maintenance.

## Calibrations

Engine performance is optimized through injection timing. Auto/manual sensor calibrations are standard features.

## On-Board System Tests

System tests are available to assist in electronic troubleshooting. These tests include: injector activation, injector cutout, and override of control outputs.

## Data Link Interfaces

The ADEM A4 communicates with the EMCP via a dedicated communication network.

## Electronic Sensing

The following sensing is available on the ADEM A4: oil pressure, fuel pressure, fuel temperature, atmospheric pressure, air inlet temperature, turbo outlet pressure, engine coolant temperature, engine speed, throttle, position, exhaust temperature, oil filter pressure differential, fuel filter pressure differential, air filter pressure differential and crankcase pressure.

## SPECIFICATIONS

### Impervious to:

Salt spray, fuel, oil and oil additives, coolant, spray cleaners, chlorinated solvents, hydrogen sulfide and methane gas, and dust.

### Input and output protection

All inputs and outputs are protected against short circuits to +battery and –battery

### Input voltage range (24 VDC nominal)

18 to 32 VDC

### Mounting

Engine mounted

### Reverse polarity protected

### Shock, withstands 20g

### Temperature range

Operating: –40°C to 85°C (–40°F to 185°F)

Storage: –50°C to 120°C (–58°F to 248°F)

### Vibration

Withstands 8.0g @ 24 to 2 kHz

Information contained in this publication may be considered confidential. Discretion is recommended when distributing. Materials and specifications are subject to change without notice.

CAT, CATERPILLAR, LET'S DO THE WORK, their respective logos, "Caterpillar Yellow," the "Power Edge" and Cat "Modern Hex" trade dress as well as corporate and product identity used herein, are trademarks of Caterpillar and may not be used without permission.

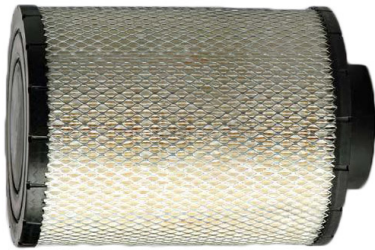

## Air Cleaner - Open Element

3412

*Picture shown may not reflect actual configuration*

### General Description

Air cleaners reduce contaminants flowing into the air intake system, provide a high level of engine protection from harmful contaminants, and help maintain optimal performance of the engine.

The open element air cleaner is a cost-effective alternative to heavy duty air cleaners in installations where protection is not required for the filter element.

### Features

- Lightweight materials
- Completely disposable
- Easy to install, durable, and reliable
- Air cleaner housing and filter are one unit
- Designed to withstand severe intake pulsations
- Polyurethane end caps

### Specification

#### Cleaner

Length 339.3 mm (13.4")

Diameter 317.5 mm (12.5")

Weight 1.74 kg (3.83 Lbs.)

Overall Efficiency	99.9%
Effective Filtering Area (m <sup>2</sup> )	8.08
Number of Convolutions	267±2
Depth of Convolutions	50.8

### General Dimension Drawing

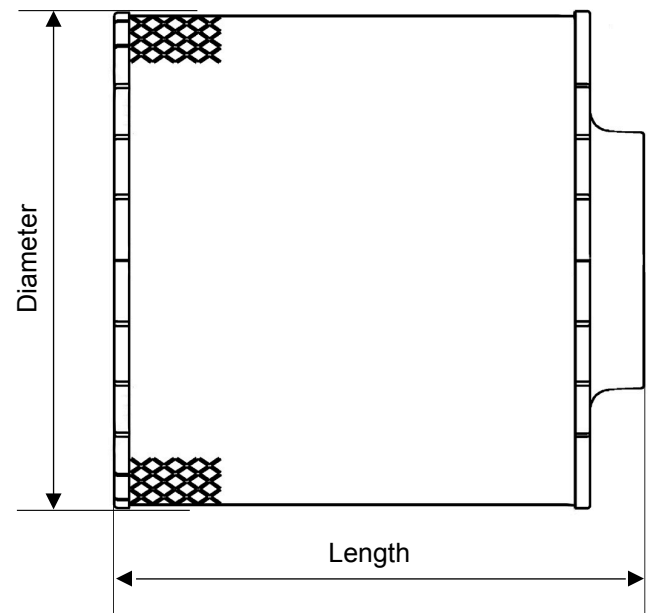

Materials and specifications are subject to change without notice.

CAT, CATERPILLAR, their respective logos, "Caterpillar Yellow," the "Power Edge" trade dress as well as corporate and product identity used herein, are trademarks of Caterpillar and may not be used without permission.



L Frame



P Frame



R Frame

## Molded Case Circuit Breakers

C27 – C32 North America built packages (60 Hz)

L-Frame  
250A-400A (UL)

P-Frame  
1200A (UL)

R-Frame  
1600-2000A (UL)

## Features

### Design Specifications:

- Moisture and fungus protection
- Clear indication of breaker status
- Reinforced insulation
- Shunt trip
- Auxiliary contacts
- Load side extension bars
- Maintenance-free operation
- Exceptional characteristics under short-circuit conditions
- Adjustable trip settings

### L-Frame

UL 489  
CSA 22.2 No 5  
Federal Specification W-C-375B/GEN  
NEMA AB1  
NMX J-266 CCC  
CE Marking

### P-Frame & R-Frame

UL 489  
CSA 22.2 No 5-02  
Federal Specification W-C-375B/GEN  
NEMA AB1  
NMX J-266



## Standard Features

### Standards

- UL-CSA
  - L-Frame
  - P-Frame
  - R-Frame

### Shunt trip

- The shunt trip provides a means of tripping the circuit breaker electronically
- Shunt trip ratings
  - Voltage: 24VDC
  - Coil Burden (Holding/Inrush): 4.5/200 VA
  - Power Consumption: 4.5 VA

### Auxiliary contacts

The auxiliary contacts provide a means of remote circuit breaker position indication and consists of (1) Form C Contact (1 Normally open and 1 Normally closed contact) with the following current ratings:

6A @ 240-480 VAC, 50/60 Hz

### Trip units

All circuit breakers come equipped with True RMS Current Sensing.

The trip units for each of the circuit breaker ratings sample the current waveform to provide true RMS protection through the 15th harmonic. This true RMS sensing gives accurate values for the magnitude of a nonsinusoidal waveform.

Therefore, the heating effects of harmonically distorted waveforms are accurately evaluated. The trip system comes equipped with a set of current transformers (CT's) to sense current, a trip unit to evaluate the current, and a tripping solenoid to trip the circuit breaker.

Additionally, each trip unit comes equipped with Active Thermal Imaging which is active 20 minutes before and after tripping.

### Customer cable connections

Extension bus bars or mechanical lugs are provided for installation of load cables.

Cat® Part Number	Frame and Rating (Amps)	IEC/UL	No. Poles	Operation	Trip Unit	Circuit Breaker Characteristics	Options	Instantaneous Override (kA RMS) +/- 10%
611-4994	250A L-Frame MCCB	UL	3	MO	3.3S LSI	Table 3	1 Aux Contact, Shunt Trip	–
421-3235	400A L-Frame MCCB	UL	3	MO	3.3S LSI	Table 3	1 Aux Contact, Shunt Trip	–
421-3237	400A L-Frame MCCB	UL	3	MO	6.3A LSIG	Table 3	1 Aux Contact, Shunt Trip	–
244-9774	1200A P-Frame MCCB	UL	3	MO	5.0A LSI	Table 1	1 Aux Contact, Shunt Trip	24
244-9864	1600A R-Frame MCCB	UL	3	MO	5.0A LSI	Table 2	1 Aux Contact, Shunt Trip	57
244-9868	2000A R-Frame MCCB	UL	3	MO	5.0A LSI	Table 2	1 Aux Contact, Shunt Trip	57
244-9778	1200A P-Frame MCCB	UL	3	MO	6.0A LSIG	Table 1	1 Aux Contact, Shunt Trip	24
244-9865	1600A R-Frame MCCB	UL	3	MO	6.0A LSIG	Table 2	1 Aux Contact, Shunt Trip	57
244-9869	2000A R-Frame MCCB	UL	3	MO	6.0A LSIG	Table 2	1 Aux Contact, Shunt Trip	57
244-9790	1200A P-Frame MCCB	UL	3	MO	6.0P LSIG-P	Table 1	1 Aux Contact, Shunt Trip, Modbus	24
585-8063	1600A R-Frame MCCB	UL	3	MO	6.0P LSIG-P	Table 2	1 Aux Contact, Shunt Trip, Modbus	57
585-8064	2000A R-Frame MCCB	UL	3	MO	6.0P LSIG-P	Table 2	1 Aux Contact, Shunt Trip, Modbus	57

### Circuit Breakers Characteristics

TABLE 1

Model		P-Frame	
Number of Poles		3	
Rated Current (Amps)		1200A (UL)	
Voltage Rating (VAC)		600UL/ 690 IEC	
Interrupt Rating (UL/CSA) (60 Hz) – kA RMS		240V	65
		480V	35
		600V	18
IEC 60947-2 Rating (50/60 Hz) – kA RMS	Icu	240V	50
		380/415V	35
	Ics	240V	25
		380/415V	20

TABLE 3

Model		L-Frame	
Number of Poles		3	
Rated Current (Amps)		250A – 400A (UL)	
Voltage Rating (VAC)		600UL/ 525 IEC	
Interrupt Rating (UL/CSA) (60 Hz) – kA RMS		240V	65
		480V	35
		600V	18
IEC 647-2 Rating (50/60 Hz) – kA RMS	Icu	240V	50
		380/415V	35
	Ics	240V	25
		380/415V	20

TABLE 2

Model		R-Frame	
Number of Poles		3	
Rated Current (Amps)		1600A – 2000A (UL)	
Voltage Rating (VAC)		600UL/ 690 IEC	
Interrupt Rating (UL/CSA) (60 Hz) – kA RMS		240V	65
		480V	35
		600V	18
IEC 60947-2 Rating (50/60 Hz) – kA RMS	Icu	240V	50
		380/415V	35
	Ics	240V	25
		380/415V	20

### L-Frame Long-Short Trip Curve

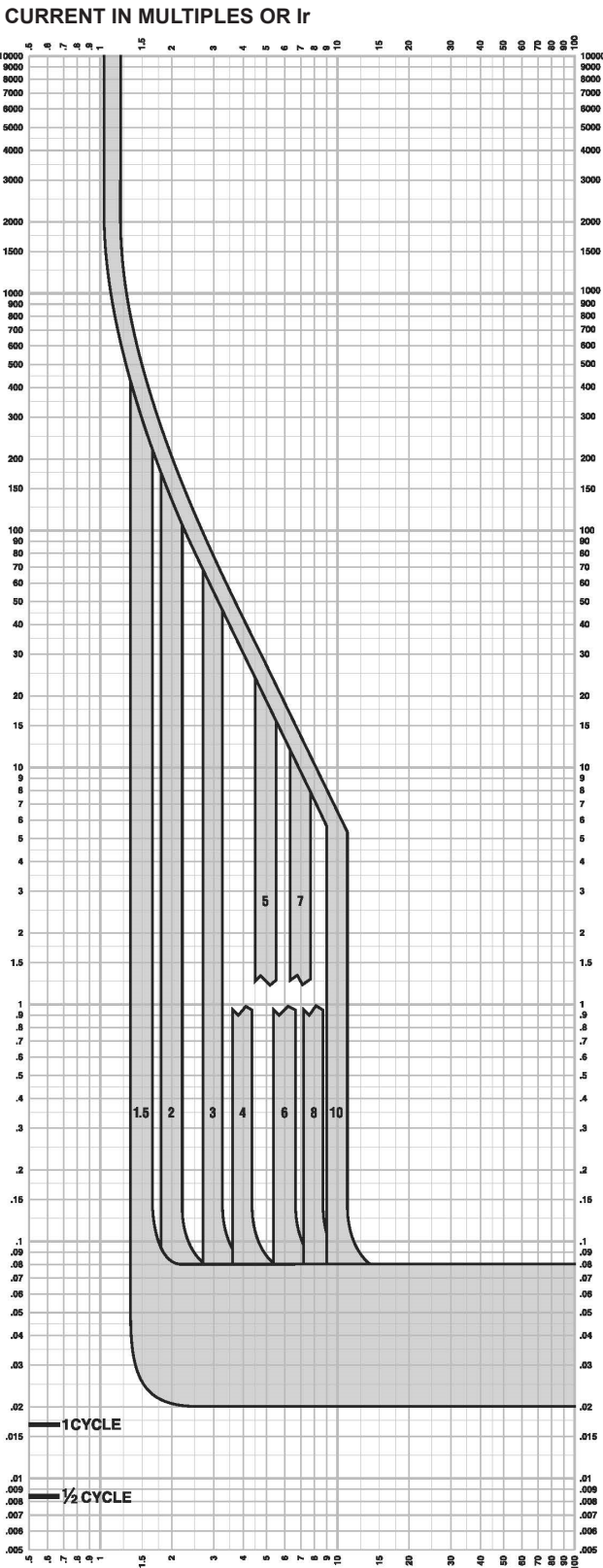

### 3.3S Long Time/Short Time Trip Curve 250A, 400A L-Frame

The time-current curve information is to be used for application and coordination purposes only.

**Notes:**

1. There is a thermal-imaging effect that can act to shorten the long-time delay. The thermal imaging effect comes into play if a current above the long-time delay pickup value exists for a time and then is cleared by the tripping of a downstream device or the circuit breaker itself. A subsequent overload will cause the circuit breaker to trip in a shorter time than normal. The amount of time delay reduction is inverse to the amount of time that has elapsed since the previous overload. Approximately 20 minutes is required between overloads to completely reset thermal-imaging.
  2. Total clearing times shown include the response times of the trip unit, the circuit breaker opening, and the extinction of the current.
- Curves apply from -35°C to +70°C (-31°F to +158°F) ambient temperature.

### L-Frame Instant Trip Curve

CURRENT IN MULTIPLES OR  $I_r$

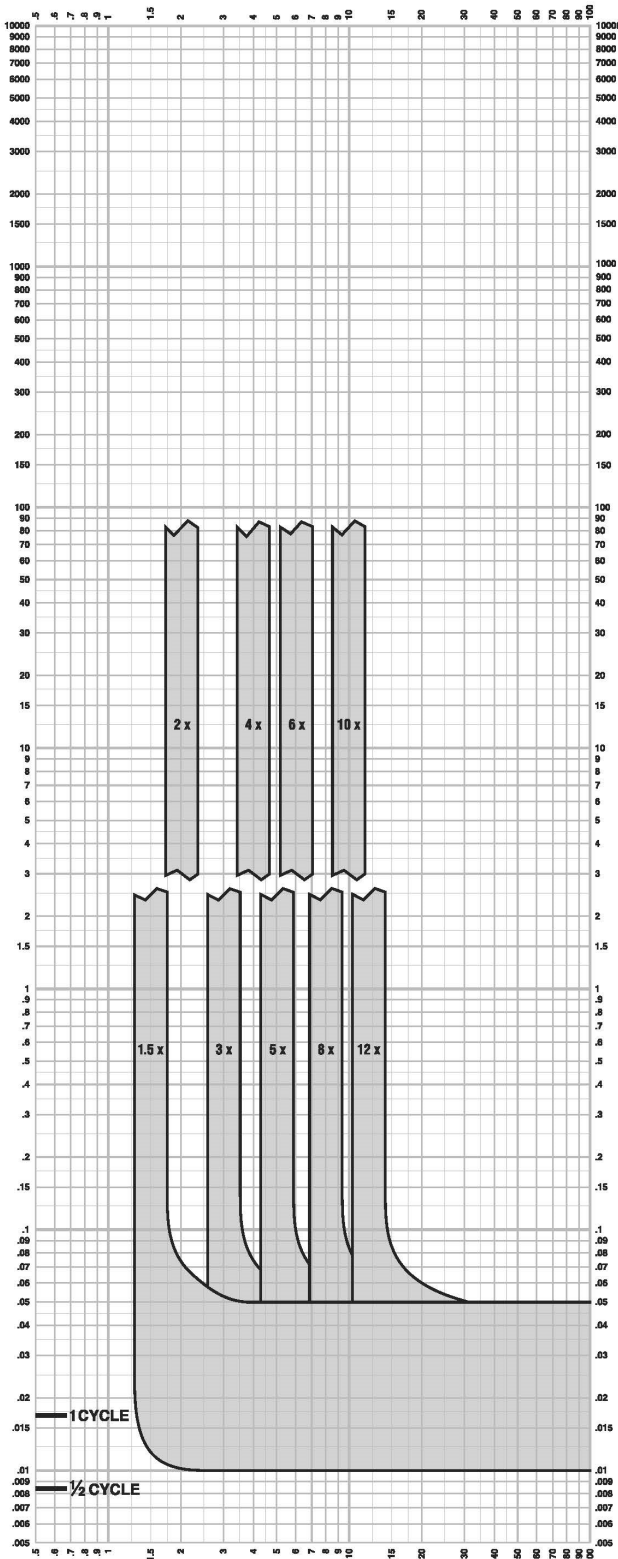

### 3.3/3.3S Instantaneous Trip Curve 250A L-Frame

The time-current curve information is to be used for application and coordination purposes only.

**Notes:**

1. There is a thermal-imaging effect that can act to shorten the long-time delay. The thermal imaging effect comes into play if a current above the longtime delay pickup value exists for a time and then is cleared by the tripping of a downstream device or the circuit breaker itself. A subsequent overload will cause the circuit breaker to trip in a shorter time than normal. The amount of time delay reduction is inverse to the amount of time that has elapsed since the previous overload. Approximately 20 minutes is required between overloads to completely reset thermal-imaging.
2. Total clearing times shown include the response times of the trip unit, the circuit breaker opening, and the extinction of the current.
3.  $I_n$  = Maximum dial setting of  $I_r$ . 250A L-Frame:  
 $I_n = 250A = \text{Max } I_r$  setting Curves apply from  $-35^\circ\text{C}$  to  $+70^\circ\text{C}$  ( $-31^\circ\text{F}$  to  $+158^\circ\text{F}$ ) ambient temperature.

### P, R, NS-Frame Long-Short Trip Curve and NW-Frame Long-Short Trip Curve

CURRENT IN MULTIPLES OF  $I_r$  ( $I_r = \text{Long-time setting} \times I_n$ )

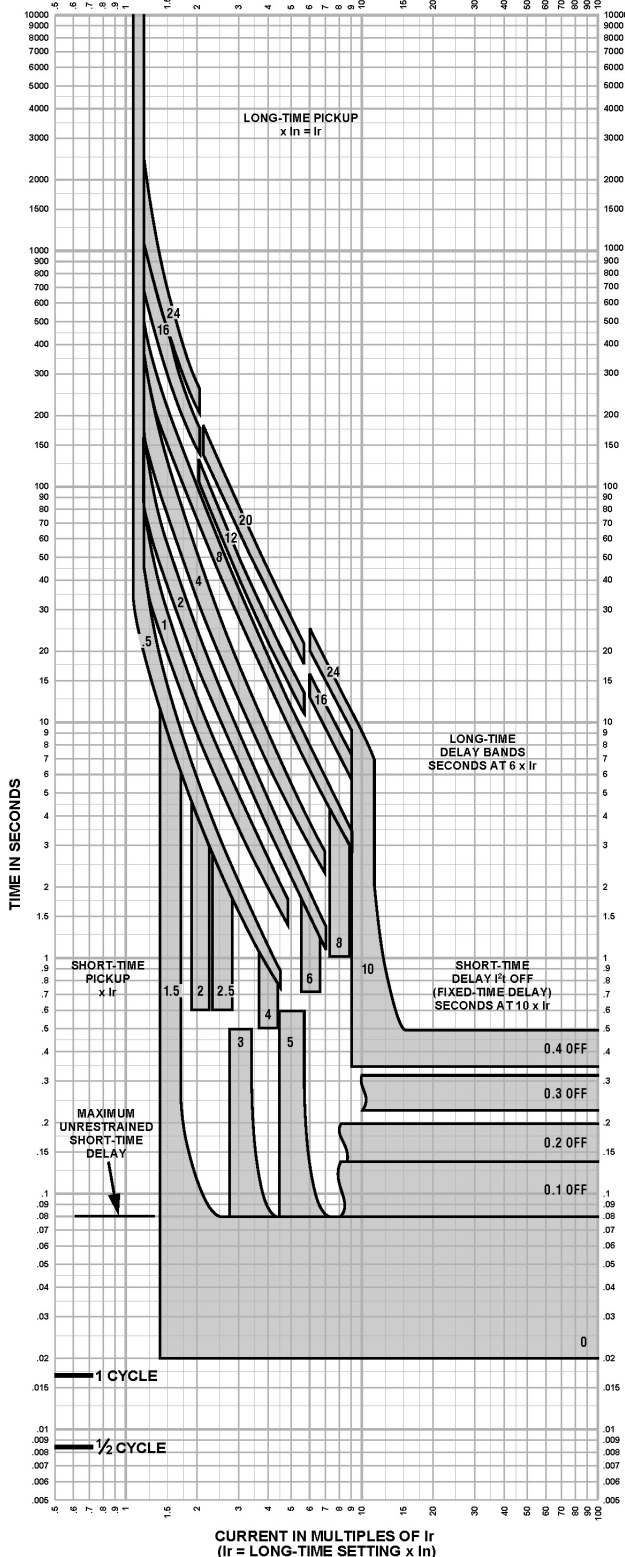

### Long-time Pickup and Delay Short-time Pickup and $I^2t$ OFF Delay

The time-current curve information is to be used for application and coordination purposes only. Curves apply from  $-30^{\circ}\text{C}$  to  $+60^{\circ}\text{C}$  ambient temperature.

**Notes:**

1. There is a thermal-imaging effect that can act to shorten the long-time delay. The thermalimaging effect comes into play if a current above the long-time delay pickup value exists for a time and then is cleared by the tripping of a downstream device or the circuit breaker itself. A subsequent overload will cause the circuit breaker to trip in a shorter time than normal. The amount of time delay reduction is inverse to the amount of time that has elapsed since the previous overload. Approximately 20 minutes is required between overloads to completely reset thermalimaging.
2. The end of the curve is determined by the interrupting rating of the circuit breaker.
3. With zone-selective interlocking on, short-time delay utilized and no restraining signal, the maximum unrestrained short-time delay time band applies regardless of the setting.
4. Total clearing times shown include the response times of the trip unit, the circuit breaker opening, and the extinction of the current.
5. For a withstand circuit breaker, instantaneous can be turned OFF.
6. Overload indicator illuminates at 100%.

### P, R, NS-Frame Instant Curve and NW-Frame Instant Trip Curve

MULTIPLES OF SENSOR RATING (I<sub>n</sub>)

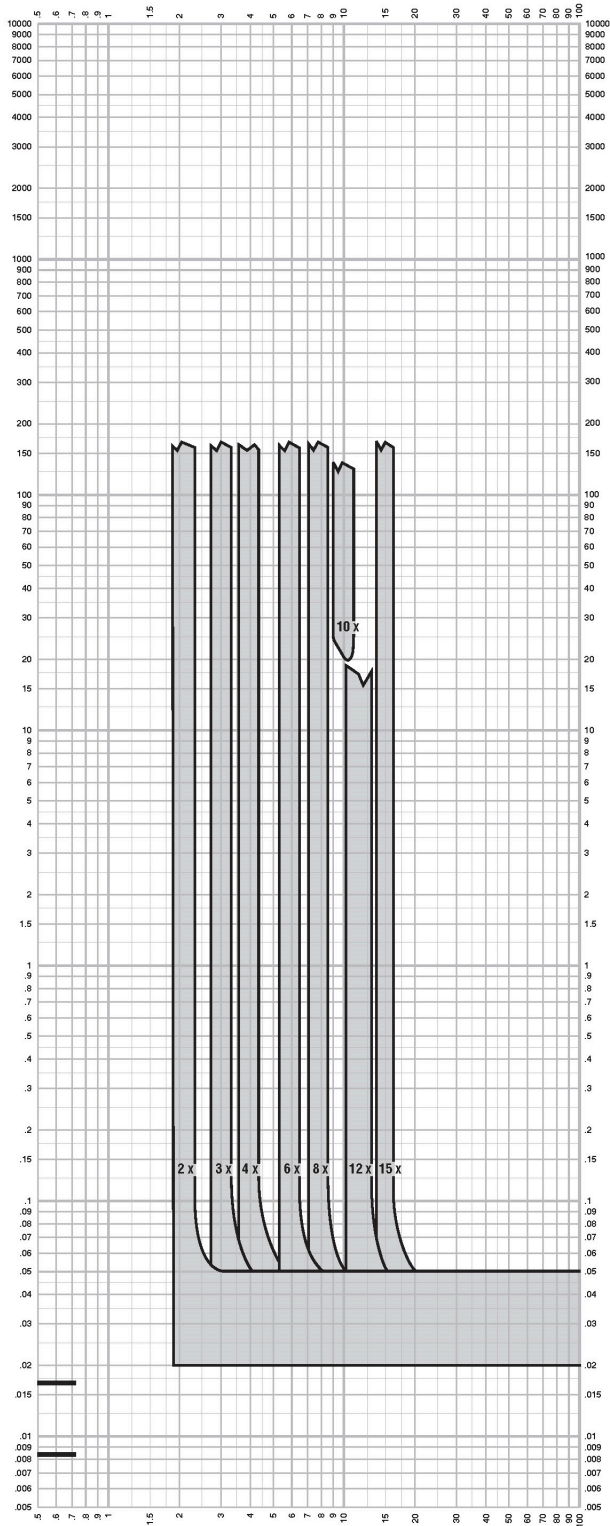

#### Instantaneous Pickup 2x–15x and OFF

The time-current curve information is to be used for application and coordination purposes only.

Curves apply from -30° to +60°C ambient temperature.

#### Notes:

1. The end of the curve is determined by the interrupting rating of the circuit breaker.
2. Total clearing times shown include the response times of the trip unit, the circuit breaker opening, and the extinction of the current.
3. The instantaneous region of the trip curve shows maximum total clearing times. Actual clearing times in this region can vary depending on the circuit breaker mechanism design and other factors. The actual clearing time can be considerably faster than indicated.  
*Contact your local Sales Office for additional information.*
4. For a withstand circuit breaker, instantaneous can be turned OFF. \

### P, R, NS-Frame Ground Curve and NW-Frame Ground Fault Trip Curve

MULTIPLES OF SENSOR RATING ( $I_n$ )

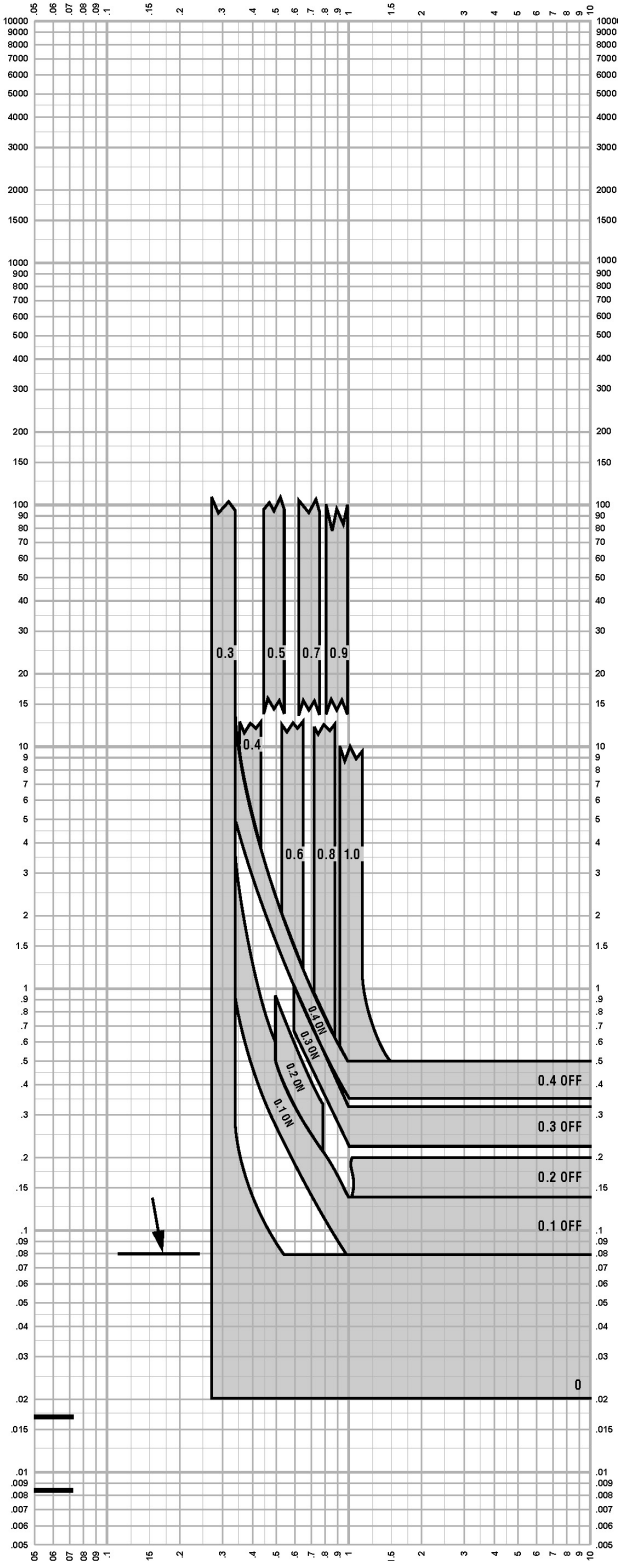

#### Ground-fault $I^2t$ OFF and ON $I_n \leq 400$ A

The time-current curve information is to be used for application and coordination purposes only.

Curves apply from  $-30^\circ$  to  $+60^\circ$ C ambient temperature.





**LET'S DO THE WORK.™**

[www.cat.com/electricpower](http://www.cat.com/electricpower)

©2021 Caterpillar  
All rights reserved.

Materials and specifications are subject to change without notice.

The International System of Units (SI) is used in this publication.  
CAT, CATERPILLAR, LET'S DO THE WORK, their respective logos, "Caterpillar Corporate Yellow" the "Power Edge" and Cat "Modern Hex" trade dress as well as corporate and product identity used herein, are trademarks of Caterpillar and may not be used without permission.

# 100 Amp Load Center



Image shown may not reflect actual package.

## 100 Amp Load Center

Specifications	
Number of spaces	8
System voltage	120 / 240 VAC
Number of tandem circuit breakers	8
Phase	1 Ph
NEMA degree of protection	NEMA 1 indoor
Electrical connection	Lugs
Wiring configuration	3-wire
Material	Tin plated aluminum busbar
Enclosure material	Welded sheet steel
Cover finish	Gray baked enamel
Product certifications	CULus
Wire Size	AWG 4...AWG 1 (Aluminum / Copper)
Rated Current	100A
Max Short Circuit Rating	10 kA
Ground Connection	Grounding bar (factory installed)
Cover Type	Surface cover with door

Dimensions and Load Specifications	
Height / Width / Depth	319 mm / 226 mm / 97 mm
GFCI	20A (120V)
Battery Charger	2.3A (240V)
Jacket Water Heater	25.4A (240V)
Alternator Heater	1.1A (240V)
Total Load	48.8A Max

L1 Load Specifications	
Battery Charger	2.3A (240V)
GFCI	20A (120V)
Jacket Water Heater	25.4A (240V)
Alternator Heater	1.1A (240V)
Total Load	48.8A Max

L2 Load Specifications	
Battery Charger	2.3A (240V)
Jacket Water Heater	25.4A (240V)
Alternator Heater	1.1A (240V)
Total Load	28.8A Max

[www.cat.com/electricpower](http://www.cat.com/electricpower)

©2020 Caterpillar  
All rights reserved.

Information contained in this publication may be considered confidential. Discretion is recommended when distributing. Materials and specifications are subject to change without notice.

CAT, CATERPILLAR, LET'S DO THE WORK, their respective logos, "Caterpillar Corporate Yellow," the "Power Edge" and Cat "Modern Hex" trade dress as well as corporate and product identity used herein, are trademarks of Caterpillar and may not be used without permission.

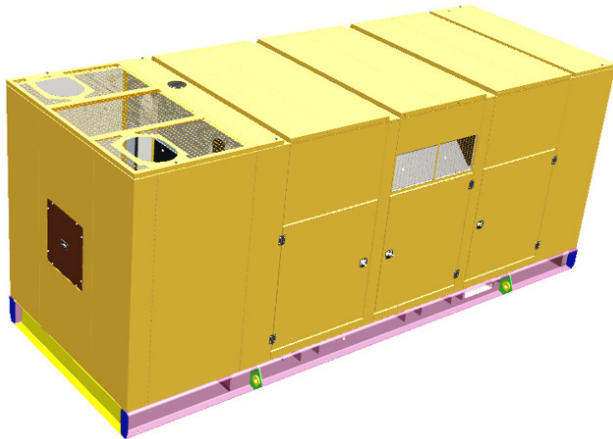

Image shown may not reflect actual configuration.

## C27 – C32 GC Enclosures NA

### Sound Attenuated Enclosures for C27 and C32 GC Generator Sets

These sound attenuated, factory installed enclosures are designed for safety and aesthetic value. Rugged construction provides weather protection and the ability to withstand exposure to the elements

## FEATURES

### Robust/Highly Corrosion-Resistant Construction

- Environmentally friendly, polyester powder-baked paint in Caterpillar White
- Zinc Plated and Stainless Steel Fasteners
- 14-Gauge Steel Construction
- Flat Roof with protection for water ingress from Rain
- Critical Grade internally mounted muffler/exhaust system
- Soft Mounted isolators
- 75 dbA @ 7m (Target value) for Sound attenuated enclosures

### Excellent Access

- Control panel mounted on RH side with an optional auxiliary box on the LH side of the package
- Large cable entry area for the ease of installation
- Left-hand or Right-hand bottom entry access to power cable bus or circuit breaker
- Multiple doors on both sides allow easy access to service points
- Hinged doors allow 180° opening rotation
- Lube Oil and coolant drains piped to exterior of enclosure and terminated drain valves
- Radiator fill cover

### Options

- Weather Proof Enclosure available with same footprint
- Interior DC lighting systems
- Caterpillar White Paint (Default)
- 2100 (Factory installed), 3000 and 4200 (shipped loose) gallon fuel tanks
- 100 mph wind loading

### Security and Safety

- Lockable access doors with standard key use
- Cooling fan and battery charging alternator fully guarded
- Oil fill and battery can only be reached via lockable access
- External fuel connections
- Externally mounted emergency stop buttons
- Designed for spreader bar lifting to ensure safety

### Certifications

- UL 2200 listed & cUL
- Seismic certification per applicable building codes: IBC 2018, CBC 2007
- Analysed to withstand 100mph wind loading
- Tested and analysed in accordance with: ASCE 7-98, ASCE 7-02, ASCE 7-05, ICC-ES AC-156

## Enclosure Weights and Dimensions

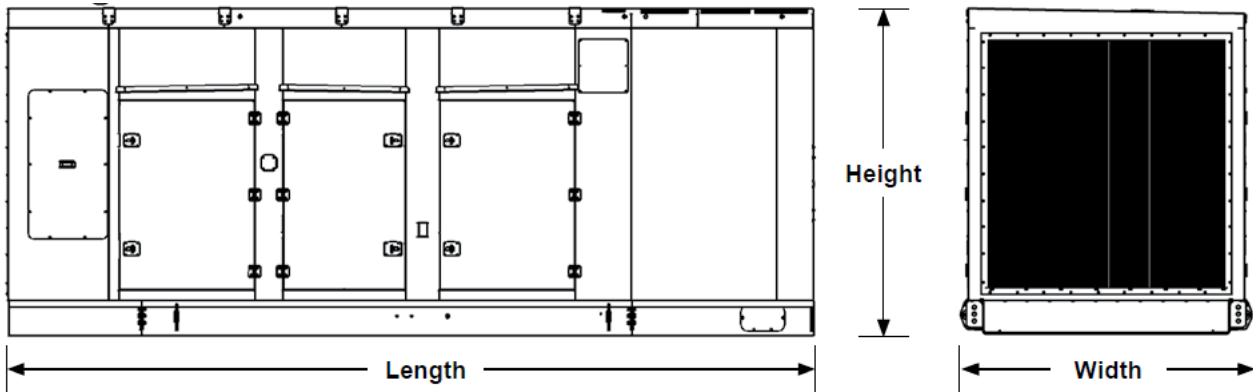

**Note:** For reference only – do not use for installation design. Please contact your dealer for exact weights and dimensions.

Enclosure Base Options*				
	Weight kgs (lbs)	Length mm (in)	Width mm (in)	Height mm (in)
With Lifting Base	2672 (5891)	6196 (244)	2300 (91)	2650 (104)
With 2100 gal integral tank base	4891 (10783)	7620 (300)	2349.5 (93)	3264.4 (129)
With 3000 gal tank with lifting base	5638 (12429)	7645 (301)	2349.5 (93)	2650 (104)
With 4200 gal tank with lifting base	6563 (14468)	7645 (301)	2349.5 (93)	2650 (104)

\*Weight does not include package generator set weight.

## Generator Set Weights

Generator Set Weights**	Weight kgs (lbs)
C27 Open Generator Set	5813 (12815)
C32 Open Generator Set	6798 (14987)

\*\*Dry Weight of heaviest configuration and without base rail weight (Does not include exhaust system weights)

**LET'S DO THE WORK.™**

[www.cat.com/electricpower](http://www.cat.com/electricpower)

©2021 Caterpillar

All rights reserved.

Materials and specifications are subject to change without notice.

The International System of Units (SI) is used in this publication. CAT, CATERPILLAR,

LET'S DO THE WORK, their respective logos, "Caterpillar Corporate Yellow"

the "Power Edge" and Cat "Modern Hex" trade dress as well as corporate and product

identity used herein, are trademarks of Caterpillar and may not be used without permission.

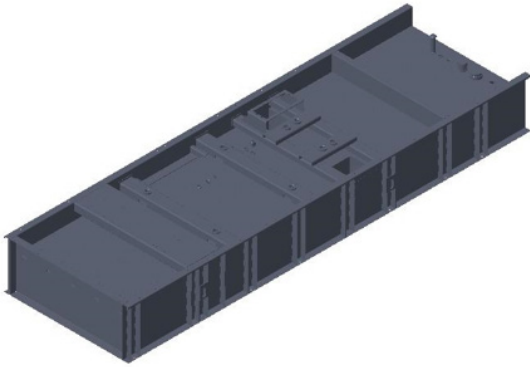

Picture shown may not reflect actual configuration

### Fuel Tank Bases for D800 GC - D1250 GC

Dual Wall fuel tank bases offer an integrated fuel solution for your Cat GC diesel generator set.

#### Features

- UL 142 (US) and ULC S601 (Canada) Listed
- Facilitates compliance to NFPA 30, 70 and 110
- CSA C282-09 and B139-04 installation compliant
- Dual wall, secondary containment (minimum of 110% of primary tank capacity)
- Tank design provides capacity for thermal expansion of fuel
- Direct reading fuel level gauge
- Fuel supply dip tube is positioned so as not to pick up fuel sediment
- Fuel return and supply dip tubes are separated by an internal baffle to prevent recirculation of heated return fuel
- Fuel fill – 43 mm (1.7 in), lockable flip top cap
- Primary tank level detection switch in containment basin
- Primary and secondary tanks are leak tested at 20.7 kPa (3 psi) minimum
- Interior tank surfaces coated with a solvent-based thin-film rust preventative
- Heavy gauge steel gussets suitable for lifting package (2100 gal only)
- Gloss black polyester alkyd acrylic enamel exterior paint over epoxy based primer
- Primary tanks are equipped with customer Lockable 2" raised fuel fill with optional seven gallon spill containment
- Leak detection switch
- Port for access to containment tank
- Removable engine supply and return dip tubes
- Fittings for opt fuel levels or auxiliary fuel pump
- Excellent stub-up access beneath circuit breaker (within fuel tank)
- Emergency vents on primary and secondary tanks are sized in accordance with NFPA 30, external to enclosure.
- Optional installed fuel level indication at the generator set control panel.
- Optional seismic certification per applicable building codes: IBC 2018 ,CBC2019
- Tested and analyzed in accordance with: ASCE 7-98, ASCE 7-02, ASCE 7-05, ICC- ES AC-156
- Anchoring details are site specific, and are dependant on many factors such as generator set size, weight, and concrete strength. IBC Certification requires that the anchoring system used is reviewed and approved by a Professional Engineer.



Standby Rating		Engine	Strategy	Run Time @ 100% Load (Hrs)		
ekW	kVA			2100 gal	3000 gal*	4200 gal*
1250	1562	C32	ESE (Tier 2)	24.3	34.8	48.7
1000	1250	C32	ESE (Tier 2)	29.4	42.0	58.7
800	1000	C27	ESE (Tier 2)	37.8	54.0	75.5

\*Requires enclosure lifting base, and fuel tank is shipped loose. Not available with IBC certification.

[www.cat.com/electricpower](http://www.cat.com/electricpower)

©2021 Caterpillar

All rights reserved.

Materials and specifications are subject to change without notice.

The International System of Units (SI) is used in this publication.

CAT, CATERPILLAR, LET'S DO THE WORK, their respective logos, "Caterpillar Corporate Yellow" the "Power Edge" and Cat "Modern Hex" trade dress as well as corporate and product identity used herein, are trademarks of Caterpillar and may not be used without permission.

**LET'S DO THE WORK.™**

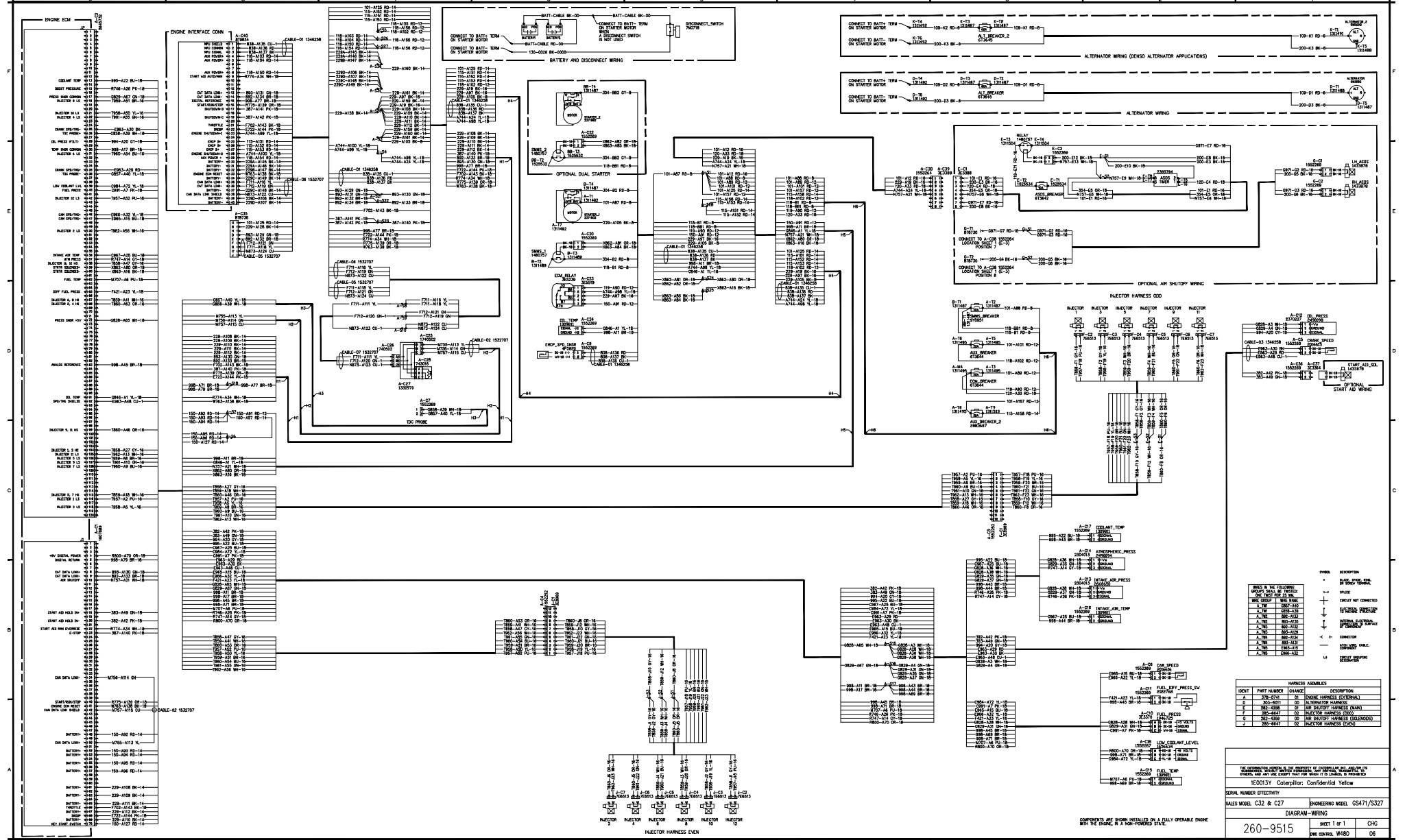

WIRE	DESCRIPTION
WIRE A	BATTERY POSITIVE
WIRE B	BATTERY NEGATIVE
WIRE C	IGNITION SWITCH
WIRE D	IGNITION SWITCH (LOCK)
WIRE E	IGNITION SWITCH (START)
WIRE F	IGNITION SWITCH (STOP)
WIRE G	IGNITION SWITCH (STOP)
WIRE H	IGNITION SWITCH (STOP)
WIRE I	IGNITION SWITCH (STOP)
WIRE J	IGNITION SWITCH (STOP)
WIRE K	IGNITION SWITCH (STOP)
WIRE L	IGNITION SWITCH (STOP)
WIRE M	IGNITION SWITCH (STOP)
WIRE N	IGNITION SWITCH (STOP)
WIRE O	IGNITION SWITCH (STOP)
WIRE P	IGNITION SWITCH (STOP)
WIRE Q	IGNITION SWITCH (STOP)
WIRE R	IGNITION SWITCH (STOP)
WIRE S	IGNITION SWITCH (STOP)
WIRE T	IGNITION SWITCH (STOP)
WIRE U	IGNITION SWITCH (STOP)
WIRE V	IGNITION SWITCH (STOP)
WIRE W	IGNITION SWITCH (STOP)
WIRE X	IGNITION SWITCH (STOP)
WIRE Y	IGNITION SWITCH (STOP)
WIRE Z	IGNITION SWITCH (STOP)

IDENT	PART NUMBER	CHANGE	DESCRIPTION
A	798-020	01	IGNITION HARNESS (EXTERNAL)
B	300-801	00	IGNITION HARNESS
C	300-808	00	IGNITION HARNESS (INTERNAL)
D	300-809	00	IGNITION HARNESS (INTERNAL)
E	300-810	00	IGNITION HARNESS (INTERNAL)
F	300-811	00	IGNITION HARNESS (INTERNAL)
G	300-812	00	IGNITION HARNESS (INTERNAL)
H	300-813	00	IGNITION HARNESS (INTERNAL)
I	300-814	00	IGNITION HARNESS (INTERNAL)
J	300-815	00	IGNITION HARNESS (INTERNAL)
K	300-816	00	IGNITION HARNESS (INTERNAL)
L	300-817	00	IGNITION HARNESS (INTERNAL)
M	300-818	00	IGNITION HARNESS (INTERNAL)
N	300-819	00	IGNITION HARNESS (INTERNAL)
O	300-820	00	IGNITION HARNESS (INTERNAL)
P	300-821	00	IGNITION HARNESS (INTERNAL)
Q	300-822	00	IGNITION HARNESS (INTERNAL)
R	300-823	00	IGNITION HARNESS (INTERNAL)
S	300-824	00	IGNITION HARNESS (INTERNAL)
T	300-825	00	IGNITION HARNESS (INTERNAL)
U	300-826	00	IGNITION HARNESS (INTERNAL)
V	300-827	00	IGNITION HARNESS (INTERNAL)
W	300-828	00	IGNITION HARNESS (INTERNAL)
X	300-829	00	IGNITION HARNESS (INTERNAL)
Y	300-830	00	IGNITION HARNESS (INTERNAL)
Z	300-831	00	IGNITION HARNESS (INTERNAL)





