



Shown with  
Optional Equipment

**STANDBY 1500 ekW**  
**PRIME 1360 ekW**

60 Hz

Caterpillar is leading the power generation marketplace with Power Solutions engineered to deliver unmatched flexibility, expandability, reliability, and cost-effectiveness.

## FEATURES

### PERFORMANCE STRATEGY OPTIONS

- Low emission and low BSFC (brake specific fuel consumption) versions available

### UL 2200

- UL 2200 Listed configuration available

### FULL RANGE OF ATTACHMENTS

- Wide range of bolt-on system expansion attachments, factory designed and tested

### SINGLE-SOURCE SUPPLIER

- Complete systems designed at Caterpillar ISO certified facilities
- **Certified Prototype Tested** with torsional analysis

### WORLDWIDE PRODUCT SUPPORT

- Worldwide parts availability through the Caterpillar dealer network
- With over 1,200 dealer outlets operating in 166 countries, you're never far from the Caterpillar part you need.
- 99.5% of parts orders filled within 48 hours. The best product support record in the industry.
- Caterpillar dealer service technicians are trained to service every aspect of your electric power generation system.
- Preventive maintenance agreements
- The Cat Scheduled Oil Sampling (S•O•S<sup>SM</sup>) program cost effectively detects internal engine component condition, even the presence of unwanted fluids and combustion by-products



### CAT® 3512B DIESEL ENGINE FAMILY

- Reliable, rugged, durable design
- Field-proven in thousands of applications worldwide
- Four-stroke-cycle diesel engine combines consistent performance and excellent fuel economy with minimum weight



### CAT SR4B GENERATOR

- Designed to match performance and output characteristics of Caterpillar diesel engines
- Optimum winding pitch for minimum total harmonic distortion and maximum efficiency
- Single point access to accessory connections



### CAT CONTROL PANELS

- Controls, designed to meet individual customer needs:
  - EMCP II+ provides full-featured power metering and protective relaying
- UL 508A Listed
- Floor standing switchgear available



**FACTORY INSTALLED STANDARD & OPTIONAL EQUIPMENT**  
**(Optional equipment listed may not be available on all packages)**

System	Standard	Optional
<b>Air Inlet</b>	Regular-duty single element canister type air cleaner with service indicator	Dual element and heavy duty air cleaners Air inlet adapters Air inlet shutoffs
<b>Cooling</b>	Jacket water pump Aftercooler water pump* Radiator sized for 43° C/110° F ambient Radiator fan and drive with guards Coolant drain line with valve Coolant level sensor Low coolant level alarm and shutdown High coolant temperature alarm and shutdown Caterpillar extended life coolant****	50° C/125° F ambient capability radiators Two circuit radiators (jacket water and aftercooler water)* ** Folded core radiators for standby applications*** Radiator removal Expansion tank with inlet/outlet connections Heat exchangers Radiator duct flange Fan Pulleys (various fan drive ratios)
<b>Exhaust</b>	Dry exhaust manifold Flange faced outlet(s)	Stainless steel exhaust flex Mufflers Elbows, flanges, expanders and Y adapters
<b>Fuel</b>	Secondary fuel filters Fuel cooler Fuel priming pump Flexible fuel lines	Primary fuel filter Primary fuel filter with water separator Duplex fuel filter
<b>Generator</b>	3 phase, brushless, statically regulated Permanent magnet exciter Digital Voltage Regulator — 3 phase sensing Class H insulation system Class F temperature rise Bus bar connections Winding temperature detectors Anti-condensation space heaters	Medium voltage and high voltage generators Oversized and premium feature generators 2/3 pitch generators Self excited generators (for standby applications) Bearing temperature RTD's Air inlet filters Extension box for cable access Circuit breakers with shunt trip and auxiliary contacts, 3 pole UL 489 Listed or 4 pole IEC 947-2 rated European bus bars Digital Voltage Regulator with KVAR/PF control
<b>Governor</b>	Electronic isochronous control	Load share module* or load share governor***
<b>Control Panels and Instrumentation</b>	EMCP II + (generator mounted, rear facing)	Customer Interface Module Customer Communications Module Synchronizing Module Local alarm modules Programmable relay control module* Relay driver module Engine failure relay Auto starting aid & switch Instrument panel, RH, 16 hole*** Remote annunciator modules Pyrometer and thermocouples (exhaust)
<b>Lube</b>	Lubricating oil Gear type lube oil pump Integral lube oil cooler Oil filter, filler and dipstick Oil drain line and valve Fumes disposal	Electric prelube pump Air prelube pump Sump pump with manual prelube Deep sump oil pan Duplex oil filter (RH service only) Oil level regulator
<b>Mounting</b>	330 mm/13 in structural steel rails Spring-type anti-vibration mounts (shipped loose)	Isolator removal
<b>Starting/Charging</b>	24 volt electric starting motor(s) 45 amp charging alternator Battery with rack and cables Battery disconnect switch	Dual and heavy duty electric starting motors Oversized batteries Battery charger Ether starting aid Jacket water coolant heater Air starting motor with control and silencer
<b>Other</b>	RH service	Switchgear (floor standing) Automatic transfer switches Enclosures Engine barring device (manual) EU Certification CSA Certification UL 2200 Listing*****

\*3500 B series only  
\*\*Standard on EPA Certified packages  
\*\*\*Not available on 3500 B series  
\*\*\*\*Not included with radiator removal, shipped loose radiator, or expansion tank  
\*\*\*\*\*Standard and optional equipment may vary for UL 2200 Listed packages

**STANDBY 1500 ekW**  
**PRIME 1360 ekW**  
**60 Hz**



**TECHNICAL DATA**

Generator Set — 1800 rpm/60 Hz/480 Volt		Standby			
		DM3067	DM3069	DM3066	DM3068
<b>Package Performance</b> Power rating @ 0.8 PF	ekW	1500	1500	1500	1500
	kVA	1875	1875	1875	1875
	Performance Strategy	Low Emissions		Low BSFC	
Coolant to aftercooler temperature (maximum)*	Deg C	60	90	60	90
<b>Fuel Consumption</b> 100% load with fan 75% load with fan 50% load with fan	L/hr	426.4	417.5	410.6	417.5
	Gal/hr	112.6	110.3	108.5	110.3
	L/hr	321.1	314.0	308.2	310.1
	Gal/hr	84.8	82.9	81.4	81.9
	L/hr	219.5	228.5	211.6	213.8
	Gal/hr	58.0	60.4	55.9	56.5
<b>Cooling System</b> Ambient air temperature Air flow restriction (system) Engine coolant capacity without radiator	Deg C	43	43	43	43
	Deg F	110	110	110	110
	kPa	0.12	0.12	0.12	0.12
	in water	0.5	0.5	0.5	0.5
	L	156.8	156.8	156.8	156.8
	Gal	41.4	41.4	41.4	41.4
<b>Exhaust System</b> Combustion air inlet flow rate Exhaust stack gas temperature Exhaust gas flow rate Exhaust flange size (internal diameter) (qty. of 2) Exhaust system backpressure (maximum allowable)	m³/min	135.7	126.6	128.7	126.6
	cfm	4792	4470	4544	4470
	Deg C	485	508	480	508
	Deg F	905	947	895	947
	m³/min	362.7	349.4	341.8	349.4
	cfm	12,807	12,337	12,069	12,337
	mm	203.0	203.0	203.0	203.0
	in	8.0	8.0	8.0	8.0
	kPa	6.7	6.7	6.7	6.7
	in water	27.0	27.0	27.0	27.0
<b>Heat Rejection</b> Heat rejection to coolant (total) Heat rejection to aftercooler Heat rejection to exhaust (total) Heat rejection to atmosphere from engine Heat rejection to atmosphere from generator	kW	653	674	637	675
	Btu/min	37,135	38,330	36,226	38,387
	kW	449	358	405	359
	Btu/min	25,534	20,359	23,032	20,416
	kW	1632	1615	1543	1624
	Btu/min	92,810	91,843	87,749	92,355
	kW	160	159	147	159
	Btu/min	9099	9042	8360	9042
<b>Alternator**</b> Motor starting capability @ 30% voltage dip Frame Temperature rise	kVA	2661	2661	2661	2661
	Deg C	697	697	697	697
	Deg C	130	130	130	130
<b>Lube System</b> Refill volume with filter change for standard sump	L	310.4	310.4	310.4	310.4
	Qts	328	328	328	328
<b>Emissions***</b> NOx CO HC PM	g/bhp-hr	8.02	11.25	9.48	11.25
	mg/N•m³ @ 5% O₂	3594	5153	4418	5153
	g/bhp-hr	2.54	2.36	2.4	2.36
	mg/N•m³ @ 5% O₂	1136	1083	1120	1083
	g/bhp-hr	0.35	0.32	0.33	0.32
	mg/N•m³ @ 5% O₂	155	149	153	149
	g/bhp-hr	0.192	0.152	0.158	0.152

\*Consult Caterpillar dealer for performance data and configuration details with 30° C aftercooler temperature. (Reference DM3065 for low emissions and DM3064 for low BSFC.)

\*\*UL 2200 Listed packages may have oversized generators with a different temperature rise and motor starting characteristics.

\*\*\*Emissions data measurement is consistent with those described in EPA CFR40 Part 86, Subpart D and ISO8178-1 for measuring HC, CO, PM, NOx.

**STANDBY 1500 ekW**  
**PRIME 1360 ekW**  
**60 Hz**



**TECHNICAL DATA**

Generator Set — 1800 rpm/60 Hz/480 Volt		Prime			
		DM3073	DM3075	DM3072	DM3074
<b>Package Performance</b> Power rating @ 0.8 PF	ekW	1360	1360	1360	1360
	kVA	1700	1700	1700	1700
	Performance Strategy	Low Emissions		Low BSFC	
Coolant to aftercooler temperature (maximum)*	Deg C	60	90	60	90
<b>Fuel Consumption</b> 100% load with fan 75% load with fan 50% load with fan	L/hr	373.8	378.7	370.7	378.7
	Gal/hr	98.7	100.1	97.9	100.0
	L/hr	278.7	292.8	278.3	278.4
	Gal/hr	73.6	77.4	73.5	73.5
	L/hr	186.0	211.4	195.3	197.6
	Gal/hr	49.1	55.9	51.6	52.2
<b>Cooling System</b> Ambient air temperature Air flow restriction (system) Engine coolant capacity without radiator	Deg C	43	43	43	43
	Deg F	110	110	110	110
	kPa	0.12	0.12	0.12	0.12
	in water	0.5	0.5	0.5	0.5
	L	156.8	156.8	156.8	156.8
	Gal	41.4	41.4	41.4	41.4
<b>Exhaust System</b> Combustion air inlet flow rate Exhaust stack gas temperature Exhaust gas flow rate Exhaust flange size (internal diameter) (qty. of 2) Exhaust system backpressure (maximum allowable)	m³/min	128	121.7	123	121.7
	cfm	4520	4297	4343	4297
	Deg C	454	481	451	481
	Deg F	849	897	845	897
	m³/min	327	323.3	313.6	323.3
	cfm	11,546	11,416	11,073	11,416
	mm	203.0	203.0	203.0	203.0
	in	8.0	8.0	8.0	8.0
	kPa	6.7	6.7	6.7	6.7
	in water	27.0	27.0	27.0	27.0
<b>Heat Rejection</b> Heat rejection to coolant (total) Heat rejection to aftercooler Heat rejection to exhaust (total) Heat rejection to atmosphere from engine Heat rejection to atmosphere from generator	kW	594	626	592	627
	Btu/min	33,780	35,601	33,666	35,657
	kW	378	306	355	307
	Btu/min	21,496	17,402	20,189	17,459
	kW	1415	1430	1373	1440
	Btu/min	80,470	81,324	78,081	81,891
	kW	137	145	132	145
	Btu/min	7791	8246	7507	8246
	kW	57.26	57.26	57.26	57.26
	Btu/min	3257	3257	3257	3257
<b>Alternator**</b> Motor starting capability @ 30% voltage dip Frame Temperature rise	kVA	2661	2661	2661	2661
		697	697	697	697
	Deg C	105	105	105	105
<b>Lube System</b> Refill volume with filter change for standard sump	L	310.4	310.4	310.4	310.4
	Qts	328	328	328	328
<b>Emissions***</b> NOx CO HC PM	g/bhp-hr	7.24	10.98	9.09	10.98
	mg/N•m³ @ 5% O₂	3230	5040	4263	5040
	g/bhp-hr	2.74	2.50	2.53	2.5
	mg/N•m³ @ 5% O₂	1224	1149	1187	1149
	g/bhp-hr	0.37	0.34	0.35	0.34
	mg/N•m³ @ 5% O₂	167	157	162	157
	g/bhp-hr	0.188	0.150	0.142	0.15

\*Consult Caterpillar dealer for performance data and configuration details with 30° C aftercooler temperature. (Reference DM3071 for low emissions and DM3070 for low BSFC.)

\*\*UL 2200 Listed packages may have oversized generators with a different temperature rise and motor starting characteristics.

\*\*\*Emissions data measurement is consistent with those described in EPA CFR40 Part 86, Subpart D and ISO8178-1 for measuring HC, CO, PM, NOx.

**SPECIFICATIONS**



**CAT SR4B GENERATOR**

Type ..... Salient pole, brushless, permanent magnet excited, static regulated

Connection ..... Three phase wye

IP rating ..... Drip proof IP22

Insulation:

— Standard package ..... Class H windings with tropicalization and antiabrasion treatment

— UL 2200 package ..... UL 1446 Recognized Class F

Overspeed capability

Prototype tested ..... 150% of rated

Production tested ..... 125% of rated

Wave form ..... < 5% deviation

Harmonic distortion ..... < 5% THD

Telephone influence factor ..... < 50

Voltage regulator ..... Digital Voltage Regulator (DVR) with 3 phase sensing, UL 508A Listed

Voltage regulation ..... < ± 1/2% (steady state)  
 < ± 1% (no load to full load at steady state conditions)

Voltage gain ..... Adjustable to compensate for line loss

Paralleling capability ..... Standard



**CAT ENGINE**

3512B 4-stroke-cycle watercooled diesel

Bore — mm (in) ..... 170 (6.7)

Stroke — mm (in) ..... 190 (7.5)

Displacement — L (cu in) ..... 51.8 (3158)

Compression ratio ..... 14:1

Aspiration ..... Turbocharged and Aftercooled

Fuel system ..... Direct unit injection

Governor type ..... Caterpillar® ADEM control system



**CAT EMCP II+ CONTROL PANEL**

24 Volt DC Control

NEMA 1, IEP23 dustproof enclosure

Lockable hinged door

Generator terminal box mounted

Single location customer connection

UL 508A Listed

Panel illuminating lights

Auto start/stop control

Voltage adjust potentiometer

True RMS AC metering

Digital indications for:

Rpm

Operating hours

Oil pressure

Coolant temperature

DC volts

L-L volts, L-N volts, Phase amps, Hz

KW, kVA, kVAR, kWhr, %kW, PF

Shutdowns with indicating lights for:

Low oil pressure

High coolant temperature

Overspeed

Emergency stop

Failure to start (overcrank)

Programmable protective relaying functions

Under and over voltage

Under and over frequency

Reverse power

Over current (phase and total)

KW level

3 spare indicator LED's (programmable)

3 spare alarm/shutdown inputs

**RATING DEFINITIONS AND CONDITIONS**

**Meets or Exceeds International Specifications:**

- ABGSM TM3, AS1359, AS2789, BS4999, BS5000, BS5514, DIN6271, DIN6280, EGSA101P, IEC34/1, ISO3046/1, ISO8528, JEM1359, NEMA MG 1-22, VDE0530, 89/392/EEC, 89/336/EEC

**Standby** — Output available with varying load for the duration of the interruption of the normal source power. Standby power in accordance with ISO8528. Fuel stop power in accordance with ISO3046/1, AS2789, DIN6271, and BS5514.

**Prime** — Output available with varying load for an unlimited time. Prime power in accordance with ISO8528. 10% overload power in accordance with ISO3046/1, AS2789, DIN6271, and BS5514 available on request.

**Continuous** — Output available without varying load for an unlimited time. Continuous power in accordance with ISO8528, ISO3046/1, AS2789, DIN6271, and BS5514.

**Ratings** are based on SAE J1349 standard conditions. These ratings also apply at ISO3046/1, DIN6271, and BS5514 standard conditions.

**Fuel rates** are based on fuel oil of 35° API (16° C or 60° F) gravity having an LHV of 42 780 kJ/kg (18,390 Btu/lb) when used at 29° C (85° F) and weighing 838.9 g/liter (7.001 lbs/U.S. gal.).

Additional ratings may be available for specific customer requirements. Consult your Caterpillar representative for details.

**S T A N D B Y    1 5 0 0   e k W**  
**P R I M E        1 3 6 0   e k W**  
**6 0   H z**



**STANDBY/PRIME POWER GENERATOR SET PACKAGE — TOP VIEW**

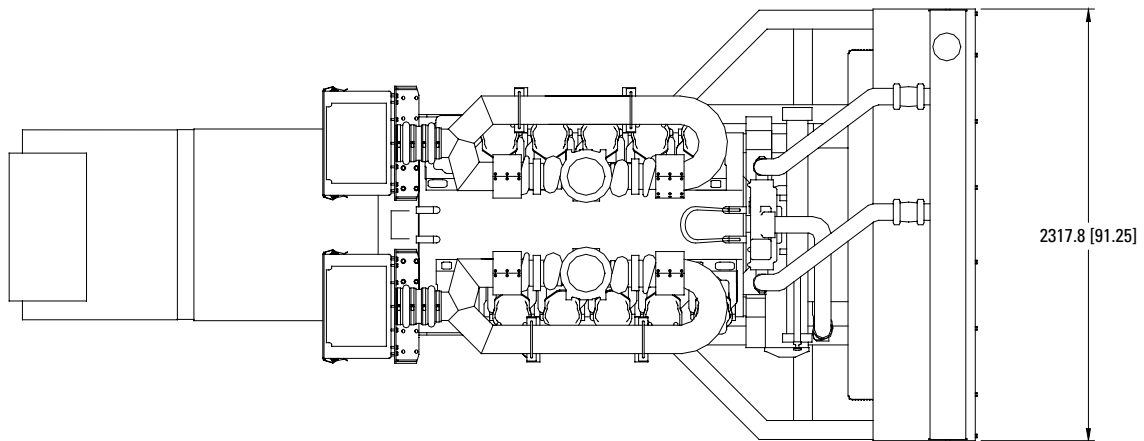

**STANDBY/PRIME POWER GENERATOR SET PACKAGE — SIDE VIEW**

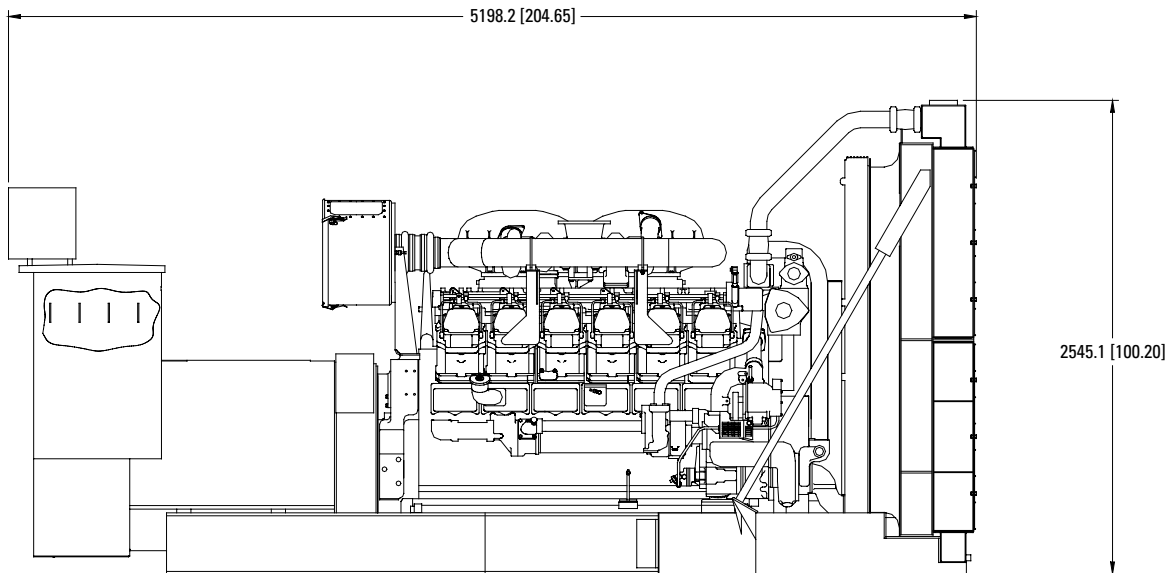

Package Dimensions		
<b>Length</b>	5198.2 mm	204.65 in
<b>Width</b>	2317.8 mm	91.25 in
<b>Height</b>	2545.1 mm	100.20 in

Note: General configuration not to be used for installation. See general dimension drawings for detail.



TMI Reference No.: DM3070, DM3071, DM3072, DM3074,  
DM3064, DM3065, DM3066, DM3067,  
DM3068, DM3069, DM3073, DM3075

[www.CAT-ElectricPower.com](http://www.CAT-ElectricPower.com)

U.S. sourced

© 2001 Caterpillar  
All rights reserved.  
Printed in U.S.A.

LEHX0770 (02-01)

Materials and specifications are subject to change without notice.  
The International System of Units (SI) is used in this publication.