



Operator Manual

Generator Set

QSX15-G9 Engine with PCC 2.3

DFEJ (Spec N)

DFEK (Spec N)

CALIFORNIA
Proposition 65 Warning

Diesel engine exhaust and some of its constituents are known to the State of California to cause cancer, birth defects, and other reproductive harm.

Table of Contents

1. IMPORTANT SAFETY INSTRUCTIONS	1
1.1 Warning, Caution, and Note Styles Used in This Manual	1
1.2 General Information	1
1.2.1 General Safety Precautions	2
1.3 Generator Set Safety Code	5
1.3.1 Moving Parts Can Cause Severe Personal Injury or Death	5
1.3.2 Positioning of Generator Set.....	5
1.3.3 Positioning of Generator Set - Open Sets	6
1.3.4 Generator Set Operating Areas	6
1.4 Electrical Shocks and Arc Flashes Can Cause Severe Personal Injury or Death.....	6
1.4.1 AC Supply and Isolation.....	6
1.5 Fuel and Fumes Are Flammable	7
1.5.1 Spillage	7
1.5.2 Fluid Containment.....	7
1.5.3 Do Not Operate in Flammable and Explosive Environments	7
1.6 Exhaust Gases Are Deadly.....	8
1.6.1 Exhaust Precautions	8
1.7 Earth Ground Connection	9
1.8 Distribution Panel Door	9
1.9 Decommissioning and Disassembly	9
2. INTRODUCTION.....	11
2.1 About This Manual	11
2.2 Schedule of Abbreviations	11
2.3 Related Literature	13
2.3.1 Further Information - Literature	13
2.4 After Sales Services.....	13
2.4.1 Maintenance.....	14
2.4.2 Warranty.....	14
2.4.3 How to Obtain Service	14
3. SYSTEM OVERVIEW	17
3.1 Generator Set Identification	17
3.1.1 Nameplate.....	17
3.1.2 Generator Set Rating	17
3.2 Generator Set Components.....	17
3.2.1 Engine Components.....	19
3.3 Generator Set Performance Data	19
3.3.1 Engine Fuel Consumption.....	19
3.3.2 Acoustic Information.....	20
3.4 Air Cleaner	20
3.4.1 Normal Duty Air Cleaner	21

3.5 System Options.....	21
3.5.1 AC Distribution Panel.....	21
3.5.2 Battery Charger - 15 Amp/12 Volt and 12 Amp/24 Volt.....	24
3.5.3 Circuit Breaker	26
3.5.4 Day Tank.....	26
3.5.5 Enclosures	27
3.5.6 Emergency Stop DC Circuit Breaker	28
3.5.7 External Receptacle.....	28
3.5.8 Fuel Transfer Pump	29
3.5.9 Generator Set Alarm.....	32
3.5.10 Heaters.....	32
3.5.11 Heavy Duty Air Cleaner	33
3.5.12 Overfill Alarm.....	33
3.5.13 Pyrometers - Engine Exhaust.....	34
3.5.14 Sensors.....	34
4. CONTROL SYSTEM - POWERCOMMAND 2.3.....	37
4.1 Control System Description	37
4.1.1 Control System Panel	37
4.1.2 Operating Modes.....	38
4.1.3 Power On and Sleep Modes.....	40
4.2 Operator Panel.....	40
4.2.1 Selection Buttons	41
4.2.2 Default Settings.....	42
4.2.3 Lamp Indicators.....	42
4.2.4 Lamp (LED) Test Button	42
4.2.5 Reset Button	42
4.2.6 Graphical Display and Buttons.....	43
4.3 Fault Messages - PowerCommand 2.3	45
4.3.1 Fault Acknowledgement.....	45
4.4 Operator Panel - Initial Operator Menu	46
4.4.1 Initial Menu Data	46
4.5 Operator Panel - Generator Set Data Operator Menu.....	48
4.5.1 Generator Set Data.....	48
4.6 Operator Panel - Engine Data Operator Menu	50
4.6.1 Engine Data Menu	50
4.6.2 History/About Menu.....	52
4.7 Operator Panel - Alternator Data Operator Menu.....	54
4.7.1 Alternator Data.....	55
4.8 Operator Panel - Faults and Warnings Menus	56
4.8.1 Shutdown Fault Menu	56
4.8.2 Fault Messages.....	57
4.8.3 Fault Acknowledgement.....	58
4.8.4 Warning Fault Menu.....	58
4.8.5 Faults History Data Operator Menu	59
4.9 Operator Panel - Adjust Menu	61

4.10 Operator Panel - Genset Setup Data Operator Menu	63
4.11 Selecting Operating Modes.....	65
4.11.1 Passwords and Mode Change Access	65
4.11.2 Selecting Manual Run Mode.....	66
4.11.3 Selecting Auto Mode.....	66
4.11.4 Selecting Off Mode	67
5. OPERATION - POWERCOMMAND 2.3	69
5.1 Safety.....	69
5.2 Introduction	69
5.3 Maintenance	70
5.4 Operating Recommendations	70
5.4.1 Running-in.....	70
5.4.2 No Load Operation.....	70
5.4.3 Exercise Period.....	70
5.4.4 Low Operating Temperatures	70
5.4.5 High Operating Temperatures	71
5.4.6 Operating Conditions	71
5.4.7 De-Rating Factors.....	72
5.5 Generator Set Operation.....	72
5.5.1 Sequence of Operation	73
5.6 Before Starting.....	73
5.6.1 Operator's Pre-Start Checks.....	74
5.6.2 Starting at the Operator Panel (Manual Run Mode)	75
5.6.3 Starting from Remote Location (Auto Mode)	76
5.6.4 Cold Starting with Loads.....	77
5.7 Stopping.....	78
5.7.1 Stopping at the Operator Panel (Manual Mode).....	78
5.7.2 Stopping from the Operator Panel (Auto Mode)	78
5.7.3 Stopping from a Remote Location (Auto Mode)	79
5.7.4 Code 1433 or 1434 - Emergency Stop	79
6. MAINTENANCE	81
6.1 Locking the Generator Set Out of Service.....	82
6.1.1 Immobilizing for Safe Working	82
6.2 Periodic Maintenance	83
6.2.1 Periodic Maintenance Schedule	83
6.3 Maintenance Procedures - Daily or When Refueling.....	85
6.3.1 General Information	85
6.3.2 Engine Operation Report	85
6.4 Cooling System.....	86
6.4.1 Water Quality Check.....	86
6.4.2 Coolant Level Check - Introduction.....	86
6.4.3 Drive Belt - Inspection.....	89
6.4.4 Radiator Check	90
6.4.5 Cooling Fan - Inspection	90
6.5 Engine Oil	91

6.5.1 Engine Oil Level Check.....	91
6.5.2 Oil Fill.....	93
6.6 Fuel System.....	94
6.6.1 Fuel Level.....	95
6.6.2 Fuel/Water Separator Drain.....	95
6.7 Hoses and Fuel Lines - Check.....	96
6.8 Air Intake System.....	97
6.8.1 Air Cleaner Service Indicator.....	97
6.8.2 Normal Duty Air Cleaner.....	98
6.8.3 Heavy Duty Air Cleaner.....	99
6.9 Exhaust System.....	101
6.10 Generator Set Output - AC Electric System.....	102
6.11 DC Electrical System.....	102
6.12 Batteries.....	103
6.12.1 Storage.....	103
6.12.2 Safety Precautions.....	103
6.12.3 Battery Maintenance.....	105
6.12.4 Electrolyte - Specific Gravity and Temperature.....	107
6.12.5 Battery Replacement.....	109
6.12.6 Battery Type Specification.....	109
6.12.7 Battery Fault Finding.....	109
7. TROUBLESHOOTING.....	111
7.1 Control System.....	111
7.2 Safety Considerations.....	111
7.3 Fault Finding.....	112
7.4 Line Circuit Breaker.....	113
7.5 Status Indicators - PowerCommand 2.3.....	113
7.5.1 Not in Auto.....	113
7.5.2 Remote Start.....	113
7.5.3 Warning.....	113
7.5.4 Shutdown Status.....	113
7.5.5 Generator Set Running Lamp.....	114
7.6 Fault/Status Codes - PowerCommand 2.3.....	114
7.6.1 Fault/Status Codes.....	114
7.6.2 Fault Messages.....	114
7.6.3 Fault Acknowledgement.....	114
7.6.4 Category A Fault Codes.....	115
7.6.5 Category B Fault Codes.....	115
7.6.6 Category C Fault Codes.....	115
7.6.7 Category D Fault Codes.....	115
7.6.8 Category E Fault Codes.....	115
7.6.9 Fault Codes - PowerCommand 2.3.....	116
7.6.10 Customer Input Faults - PowerCommand 2.3.....	121
8. MANUFACTURING FACILITIES.....	127
8.1 How to Obtain Service.....	127

8.1.1 Locating a Distributor	127
------------------------------------	-----

This page is intentionally blank.

1 IMPORTANT SAFETY INSTRUCTIONS

SAVE THESE INSTRUCTIONS. This manual contains important instructions that should be followed during installation and maintenance of the generator set and batteries.

Safe and efficient operation can be achieved only if the equipment is properly operated and maintained. Many accidents are caused by failure to follow fundamental rules and precautions.

1.1 Warning, Caution, and Note Styles Used in This Manual

The following safety styles and symbols found throughout this manual indicate potentially hazardous conditions to the operator, service personnel, or equipment.

 DANGER
<i>Indicates a hazardous situation that, if not avoided, will result in death or serious injury.</i>

 WARNING
<i>Indicates a hazardous situation that, if not avoided, could result in death or serious injury.</i>

 CAUTION
<i>Indicates a hazardous situation that, if not avoided, could result in minor or moderate injury.</i>

NOTICE
Indicates information considered important, but not hazard-related (e.g., messages relating to property damage).

1.2 General Information

This manual should form part of the documentation package supplied by Cummins with specific generator sets. In the event that this manual has been supplied in isolation, please contact your authorized distributor.

NOTICE
It is in the operator's interest to read and understand all warnings and cautions contained within the documentation relevant to the generator set, its operation and daily maintenance.

1.2.1 General Safety Precautions

WARNING

Hot Pressurized Liquid

Contact with hot liquid can cause severe burns.

Do not open the pressure cap while the engine is running. Let the engine cool down before removing the cap. Turn the cap slowly and do not open it fully until the pressure has been relieved.

WARNING

Moving Parts

Moving parts can cause severe personal injury.

Use extreme caution around moving parts. All guards must be properly fastened to prevent unintended contact.

WARNING

Toxic Hazard

Used engine oils have been identified by some state and federal agencies to cause cancer or reproductive toxicity.

Do not ingest, breathe the fumes, or contact used oil when checking or changing engine oil. Wear protective gloves and face guard.

WARNING

Electrical Generating Equipment

Incorrect operation can cause severe personal injury or death.

Do not operate equipment when fatigued, or after consuming any alcohol or drug.

WARNING

Toxic Gases

Substances in exhaust gases have been identified by some state and federal agencies to cause cancer or reproductive toxicity.

Do not breathe in or come into contact with exhaust gases.

WARNING

Combustible Liquid

Ignition of combustible liquids is a fire or explosion hazard which can cause severe burns or death.

Do not store fuel, cleaners, oil, etc., near the generator set.

WARNING

High Noise Level

Generator sets in operation emit noise, which can cause hearing damage.

Wear appropriate ear protection at all times.

⚠ WARNING**Hot Surfaces**

Contact with hot surfaces can cause severe burns.

The unit is to be installed so that the risk of hot surface contact by people is minimized. Wear appropriate PPE when working on hot equipment and avoid contact with hot surfaces.

⚠ WARNING**Electrical Generating Equipment**

Incorrect operation and maintenance can result in severe personal injury or death.

Make sure that only suitably trained and experienced service personnel perform electrical and/or mechanical service.

⚠ WARNING**Toxic Hazard**

Ethylene glycol, used as an engine coolant, is toxic to humans and animals.

Wear appropriate PPE. Clean up coolant spills and dispose of used coolant in accordance with local environmental regulations.

⚠ WARNING**Combustible Liquid**

Ignition of combustible liquids is a fire or explosion hazard which can cause severe burns or death.

Do not use combustible liquids like ether.

⚠ WARNING**Automated Machinery**

Accidental or remote starting of the generator set can cause severe personal injury or death.

Isolate all auxiliary supplies and use an insulated wrench to disconnect the starting battery cables (negative [-] first).

⚠ WARNING**Fire Hazard**

Materials drawn into the generator set are a fire hazard. Fire can cause severe burns or death.

Make sure the generator set is mounted in a manner to prevent combustible materials from accumulating under the unit.

⚠ WARNING**Fire Hazard**

Accumulated grease and oil are a fire hazard. Fire can cause severe burns or death.

Keep the generator set and the surrounding area clean and free from obstructions. Repair oil leaks promptly.

⚠ WARNING**Fall Hazard**

Falls can result in severe personal injury or death.

Make sure that suitable equipment for performing tasks at height are used in accordance with local guidelines and legislation.

⚠ WARNING**Fire Hazard**

Materials drawn into the generator set are a fire hazard. Fire can cause severe burns or death.

Keep the generator set and the surrounding area clean and free from obstructions.

⚠ WARNING**Pressurized System**

Pressurized systems can rupture/leak which can result in severe personal injury or death.

Use appropriate lock out/tag out safety procedures to isolate from all energy sources before performing any service tasks. Use PPE.

⚠ WARNING**Confined Areas**

Confined spaces or areas with restricted access or potential to entrap can cause severe personal injury or death.

Use appropriate lock out/tag out safety procedures to isolate from all energy sources. Use PPE. Follow site specific lone worker protocols/permits to work.

⚠ CAUTION**Manual Handling Heavy Objects**

Handling heavy objects can cause severe personal injury.

Use appropriate lifting equipment and perform tasks with two people where doing so would make completion of the task safe.

⚠ CAUTION**Power Tools and Hand Tools**

Tools can cause cuts, abrasions, bruising, puncture injuries.

Only trained and experienced personnel should use power tools and hand tools. Use PPE.

⚠ CAUTION**Sharp Edges and Sharp Points**

Projecting corners/parts may cause cuts, abrasions and other personal injury.

Use PPE. Be aware of sharp edges and corners/sharp points. Cover/protect them.

NOTICE

Keep multi-type ABC fire extinguishers close by. Class A fires involve ordinary combustible materials such as wood and cloth. Class B fires involve combustible and flammable liquid fuels and gaseous fuels. Class C fires involve live electrical equipment. (Refer to NFPA No. 10 in the applicable region.)

NOTICE

Before performing maintenance and service procedures on enclosed generator sets, make sure the service access doors are secured open.

NOTICE

Stepping on the generator set can cause parts to bend or break, leading to electrical shorts, or to fuel leaks, coolant leaks, or exhaust leaks. Do not step on the generator set when entering or leaving the generator set room.

NOTICE

Remove fuel from subbase fuel tank before conducting any hot work.

1.3 Generator Set Safety Code

Before operating the generator set, read the manuals and become familiar with them and the equipment. Safe and efficient operation can be achieved only if the equipment is properly operated and maintained. Many accidents are caused by failure to follow fundamental rules and precautions.

⚠ WARNING***Electrical Generating Equipment***

Incorrect operation and maintenance can result in severe personal injury or death.

Read and follow all Safety Precautions, Warnings, and Cautions throughout this manual and the documentation supplied with the generator set.

1.3.1 Moving Parts Can Cause Severe Personal Injury or Death

- Keep hands, clothing, and jewelry away from moving parts.
- Before starting work on the generator set, disconnect the battery charger from its AC source, then disconnect the starting batteries using an insulated wrench, negative (–) cable first. This will prevent accidental starting.
- Make sure that fasteners on the generator set are secure. Tighten supports and clamps; keep guards in position over fans, drive belts, etc.
- Do not wear loose clothing or jewelry in the vicinity of moving parts or while working on electrical equipment. Loose clothing and jewelry can become caught in moving parts.
- If any adjustments must be made while the unit is running, use extreme caution around hot manifolds, moving parts, etc.

1.3.2 Positioning of Generator Set

The generator set should be placed on level ground with adequate open space around it. The immediate area around the generator set should be free of any flammable material.

NOTICE

Access or service doors must be closed and locked before repositioning, and they must remain locked during transportation and siting.

NOTICE

The generator set is capable of operating at inclines of up to +/- 2.5 degrees.

1.3.3 Positioning of Generator Set - Open Sets

The area for positioning the set should be adequate and level, and the area immediately around the set must be free of any flammable material.

1.3.4 Generator Set Operating Areas

⚠ WARNING***Ejected Debris***

Debris ejected during destructive failure can cause serious injury or death by impact, severing or stabbing.

Do not to stand alongside the engine or alternator while the generator set is running.

- Operators must not stand alongside the engine or alternator while the generator set is running, unless the risks of doing so have been assessed and adequate mitigation steps have been taken.
- If there are operation/maintenance procedures that require spending time alongside the generator set when it is running, take every precaution to perform these tasks safely. Keep time spent performing these tasks to a minimum.
- Be aware of the product environment. Other equipment may be in operation or energized in the surrounding area.

1.4 Electrical Shocks and Arc Flashes Can Cause Severe Personal Injury or Death

- Only qualified service personnel certified and authorized to work on power circuits should work on exposed energized power circuits.
- All relevant service material must be available for any electrical work performed by certified service personnel.
- Exposure to energized power circuits with potentials of 50 VAC or 75 VDC or higher poses a significant risk of electrical shock and electrical arc flash.
- Refer to standard NFPA 70E, or equivalent safety standards in corresponding regions, for details of the dangers involved and for safety requirements.

1.4.1 AC Supply and Isolation

NOTICE

Local electrical codes and regulations (for example, *BS EN 12601:2010 Reciprocating internal combustion engine driven generating sets*) may require the installation of a disconnect means for the generator set, either on the generator set or where the generator set conductors enter a facility.

NOTICE

The AC supply must have the correct over current and earth fault protection according to local electrical codes and regulations. This equipment must be earthed (grounded).

It is the sole responsibility of the customer to provide AC power conductors for connection to load devices and the means to isolate the AC input to the terminal box; these must comply with local electrical codes and regulations. Refer to the wiring diagram supplied with the generator set.

The disconnecting device is not provided as part of the generator set, and Cummins accepts no responsibility for providing the means of isolation.

1.5 Fuel and Fumes Are Flammable

Fire, explosion, and personal injury or death can result from improper practices.

- Do not fill fuel tanks while the engine is running unless the tanks are outside the engine compartment. Fuel contact with hot engine or exhaust is a potential fire hazard.
- Do not permit any flame, cigarette, pilot light, spark, arcing equipment, or other ignition source near the generator set or fuel tank.
- Fuel lines must be adequately secured and free of leaks. Fuel connection at the engine should be made with an approved flexible line. Do not use copper piping on flexible lines as copper will become brittle if continuously vibrated or repeatedly bent.
- Make sure all fuel supplies have a positive shutoff valve.
- Make sure the battery area has been well-ventilated prior to servicing near it. Lead-acid batteries emit a highly explosive hydrogen gas that can be ignited by arcing, sparking, smoking, etc.

1.5.1 Spillage

Any spillage that occurs during fueling, oil top-off, or oil change must be cleaned up before starting the generator set.

1.5.2 Fluid Containment

NOTICE

Where spillage containment is not part of a Cummins supply, it is the responsibility of the installer to provide the necessary containment to prevent contamination of the environment, especially water courses and sources.

If fluid containment is incorporated into the bedframe, it must be inspected at regular intervals. Any liquid present should be drained out and disposed of in line with local health and safety regulations. Failure to perform this action may result in spillage of liquids which could contaminate the surrounding area.

Any other fluid containment area must also be checked and emptied, as described above.

1.5.3 Do Not Operate in Flammable and Explosive Environments

Flammable vapor can cause an engine to over speed and become difficult to stop, resulting in possible fire, explosion, severe personal injury, and death. Do not operate a generator set where a flammable vapor environment can be created, unless the generator set is equipped with an automatic safety device to block the air intake and stop the engine. The owners and operators of the generator set are solely responsible for operating the generator set safely. Contact your authorized Cummins distributor for more information.

1.6 Exhaust Gases Are Deadly

- Provide an adequate exhaust system to properly expel discharged gases away from enclosed or sheltered areas, and areas where individuals are likely to congregate. Visually and audibly inspect the exhaust system daily for leaks per the maintenance schedule. Make sure that exhaust manifolds are secured and not warped. Do not use exhaust gases to heat a compartment.
- Make sure the unit is well ventilated.

1.6.1 Exhaust Precautions

WARNING

Hot Exhaust Gases

Contact with hot exhaust gases can cause severe burns.

Wear personal protective equipment when working on equipment.

WARNING

Hot Surfaces

Contact with hot surfaces can cause severe burns.

The unit is to be installed so that the risk of hot surface contact by people is minimized. Wear appropriate PPE when working on hot equipment and avoid contact with hot surfaces.

WARNING

Toxic Gases

Inhalation of exhaust gases can cause asphyxiation and death.

Pipe exhaust gas outside and away from windows, doors, or other inlets to buildings. Do not allow exhaust gas to accumulate in habitable areas.

WARNING

Fire Hazard

Contaminated insulation is a fire hazard. Fire can cause severe burns or death.

Remove any contaminated insulation and dispose of it in accordance with local regulations.

The exhaust outlet may be sited at the top or bottom of the generator set. Make sure that the exhaust outlet is not obstructed. Personnel using this equipment must be made aware of the exhaust position. Position the exhaust away from flammable materials - in the case of exhaust outlets at the bottom, make sure that vegetation is removed from the vicinity of the exhaust.

The exhaust pipes may have some insulating covers fitted. If these covers become contaminated they must be replaced before the generator set is run.

To minimize the risk of fire, make sure the following steps are observed:

- Make sure that the engine is allowed to cool thoroughly before performing maintenance or operation tasks.
- Clean the exhaust pipe thoroughly.

1.7 Earth Ground Connection

The neutral of the generator set may be required to be bonded to earth ground at the generator set location, or at a remote location, depending on system design requirements. Consult the engineering drawings for the facility or a qualified electrical design engineer for proper installation.

NOTICE

The end user is responsible to make sure that the ground connection point surface area is clean and free of rust before making a connection.

NOTICE

The end user is responsible for making sure that an earthing arrangement that is compliant with local conditions is established and tested before the equipment is used.

1.8 Distribution Panel Door

NOTICE

Opening the distribution panel door while the generator set is running will trip the generator set circuit breaker and abruptly shut off power to all loads. Make sure that the generator set is not running and is in off mode before you open the distribution panel door.

1.9 Decommissioning and Disassembly

NOTICE

Decommissioning and disassembly of the generator set at the end of its working life must comply with local guidelines and legislation for disposal/recycling of components and contaminated fluids. This procedure must only be carried out by suitably trained and experienced service personnel. For more information contact your authorized distributor.

This page is intentionally blank.

2 Introduction

WARNING

Hazardous Voltage

Contact with high voltages can cause severe electrical shock, burns, or death.

Make sure that only a trained and experienced electrician makes generator set electrical output connections, in accordance with the installation instructions and all applicable codes.

WARNING

Electrical Generating Equipment

Faulty electrical generating equipment can cause severe personal injury or death.

Generator sets must be installed, certified, and operated by trained and experienced persons in accordance with the installation instructions and all applicable codes.

2.1 About This Manual

The purpose of this manual is to provide the users with accurate, general information. It is for guidance and assistance with recommendations for correct and safe procedures. Cummins cannot accept any liability whatsoever for problems arising as a result of following recommendations in this manual.

The information contained within the manual is based on information available at the time of going to print. In line with Cummins policy of continuous development and improvement, information may change at any time without notice. The users should therefore make sure that before commencing any work, they have the latest information available. The latest version of this manual is available on QuickServe Online (<https://quickserve.cummins.com>).

Users are respectfully advised that, in the interests of good practice and safety, it is their responsibility to employ competent persons to carry out any installation work. Consult your authorized distributor for further installation information. It is essential that the utmost care is taken with the application, installation, and operation of any engine due to their potentially hazardous nature. Careful reference should also be made to other Cummins literature. A generator set must be operated and maintained properly for safe and reliable operation.

For further assistance, contact your authorized distributor.

2.2 Schedule of Abbreviations

This list is not exhaustive. For example, it does not identify units of measure or acronyms that appear only in parameters, event/fault names, or part/accessory names.

ABBR.	DESCRIPTION	ABBR.	DESCRIPTION
AC	Alternating Current	LED	Light-emitting Diode
AMP	AMP, Inc., part of Tyco Electronics	LTS	Long Term Storage
ANSI	American National Standards Institute	LVRT	Low Voltage Ride Through
ASOV	Automatic Shut Off Valve	MFM	Multifunction Monitor

ABBR.	DESCRIPTION	ABBR.	DESCRIPTION
ASTM	American Society for Testing and Materials (ASTM International)	Mil Std	Military Standard
ATS	Automatic Transfer Switch	MLD	Masterless Load Demand
AVR	Automatic Voltage Regulator	NC	Normally Closed
AWG	American Wire Gauge	NC	Not Connected
CAN	Controlled Area Network	NFPA	National Fire Protection Agency
CB	Circuit Breaker	NO	Normally Open
CE	Conformité Européenne	NWF	Network Failure
CFM	Cubic Feet per Minute	OEM	Original Equipment Manufacturer
CGT	Cummins Generator Technologies	OOR	Out of Range
CMM	Cubic Meters per Minute	OORH / ORH	Out of Range High
CT	Current Transformer	OORL / ORL	Out of Range Low
D-AVR	Digital Automatic Voltage Regulator	PB	Push Button
DC	Direct Current	PCC	PowerCommand® Control
DEF	Diesel Exhaust Fluid	PGI	Power Generation Interface
DPF	Diesel Particulate Filter	PGN	Parameter Group Number
ECM	Engine Control Module	PI	Proportional/Integral
ECS	Engine Control System	PID	Proportional / Integral / Derivative
EMI	Electromagnetic interference	PLC	Programmable Logic Controller
EN	European Standard	PMG	Permanent Magnet Generator
EPS	Engine Protection System	PPE	Personal Protective Equipment
E-Stop	Emergency Stop	PT	Potential Transformer
FAE	Full Authority Electronic	PTC	Power Transfer Control
FMI	Failure Mode Identifier	PWM	Pulse-width Modulation
FRT	Fault Ride Through	RFI	Radio Frequency Interference
FSO	Fuel Shutoff	RH	Relative Humidity
Genset	Generator Set	RMS	Root Mean Square
GCP	Generator Control Panel	RTU	Remote Terminal Unit
GND	Ground	SAE	Society of Automotive Engineers
LCT	Low Coolant Temperature	SCR	Selective Catalytic Reduction
HMI	Human-machine Interface	SPN	Suspect Parameter Number
IC	Integrated Circuit	SWL	Safe Working Load
ISO	International Organization for Standardization	SW_B+	Switched B+

ABBR.	DESCRIPTION	ABBR.	DESCRIPTION
LBNG	Lean-burn Natural Gas	UL	Underwriters Laboratories
LCD	Liquid Crystal Display	UPS	Uninterruptible Power Supply
		VPS	Valve Proving System

2.3 Related Literature

Before any attempt is made to operate the generator set, the operator should take time to read all of the manuals supplied with the generator set, and to familiarize themselves with the warnings and operating procedures .

CAUTION

A generator set must be operated and maintained properly if you are to expect safe and reliable operation. The Operator manual includes a maintenance schedule and a troubleshooting guide.

The relevant manuals appropriate to your generator set are also available, the documents below are in English:

- Operator Manual for DFEJ and DFEK with PC 2.3 (A052B677)
- Installation Manual for DFEJ and DFEK with PC 2.3 (A052B680)
- Service Manual for DFEJ and DFEK with PC 2.3 (A052B682)
- Controller Service Manual for PC 2.3 (0900-0666)
- Engine Operation & Maintenance Manual for QSX15 Engine (3666423)
- Alternator Service Manual for HC Alternator (0900-9904)
- Specification and Data Sheet
- *Application Manual T-030: Liquid Cooled Generator Sets*
- Parts Manual for DFEJ and DFEK with QSX15 Engine (A040G238)
- Standard Repair Times - CH Family (A034H046)
- Global Commercial Warranty Statement (A028U870)

2.3.1 Further Information - Literature

Contact your authorized distributor for more information regarding related literature for this product.

2.4 After Sales Services

Cummins offers a full range of maintenance and warranty services.

2.4.1 Maintenance

WARNING

Electrical Generating Equipment

Incorrect operation and maintenance can result in severe personal injury or death.

Make sure that only suitably trained and experienced service personnel perform electrical and/or mechanical service.

For expert generator set service at regular intervals, contact your local distributor. Each local distributor offers a complete maintenance contract package covering all items subject to routine maintenance, including a detailed report on the condition of the generator set. In addition, this can be linked to a 24-hour call-out arrangement, providing year-round assistance if necessary. Specialist engineers are available to maintain optimum performance levels from generator sets. Maintenance tasks should only be undertaken by trained and experienced technicians provided by your authorized distributor.

2.4.2 Warranty

For details of the warranty coverage for your generator set, refer to the Global Commercial Warranty Statement listed in the Related Literature section.

In the event of a breakdown, prompt assistance can normally be given by factory trained service technicians with facilities to undertake all minor and many major repairs to equipment on site.

Extended warranty coverage is also available.

For further warranty details, contact your authorized service provider.

NOTICE

Damage caused by failure to follow the manufacturer's recommendations will not be covered by the warranty. Please contact your authorized service provider.

2.4.2.1 Warranty Limitations

For details of the warranty limitations for your generator set, refer to the warranty statement applicable to the generator set.

2.4.3 How to Obtain Service

When a product requires servicing, contact the nearest Cummins service provider. To locate the distributor, go to www.cummins.com/support and select Sales and Service Locator. When contacting the service provider, always supply the complete model, specification, and serial number as shown on the nameplate.

2.4.3.1 Locating a Distributor

In the U.S. and Canada

To easily locate the nearest certified distributor/dealer for Cummins generator sets in your area, or for more information, contact us at 1-800-CUMMINS™ (1-800-286-6467) or visit www.cummins.com/support.

If unable to contact a distributor using the automated service, consult the Internet.

If unable to arrange a service or resolve an issue, contact the Service Manager at the nearest Cummins distributor for assistance.

When contacting the distributor, always supply the complete Model, Specification, and Serial Number as shown on the product nameplate.

Outside the U.S. and Canada

Refer to www.cummins.com/support and select Sales and Service Locator, or send an email to ask.powergen@cummins.com.

This page is intentionally blank.

3 System Overview

This section provides an overview of the generator set.

3.1 Generator Set Identification

Each generator set is provided with a nameplate similar to that shown below. The nameplate provides information unique to the generator set.

3.1.1 Nameplate

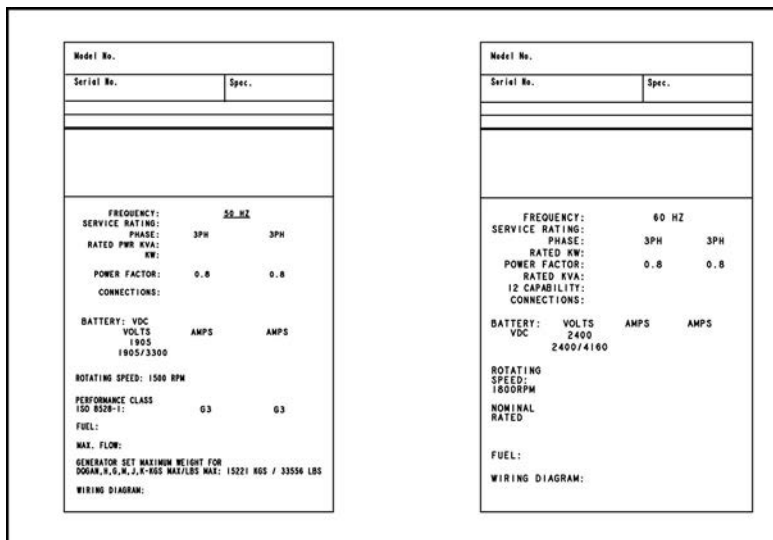

FIGURE 1. TYPICAL GENERATOR SET NAMEPLATE

3.1.2 Generator Set Rating

Refer to the generator set nameplate for generator set rating. Refer to [Section 5.4 on page 70](#) for operation at temperatures or altitudes above those stated on the nameplate.

3.2 Generator Set Components

The main components of a typical QSX15-G9 generator set are shown below and referred to within this section.

There are various options listed although they may not be available for all models.

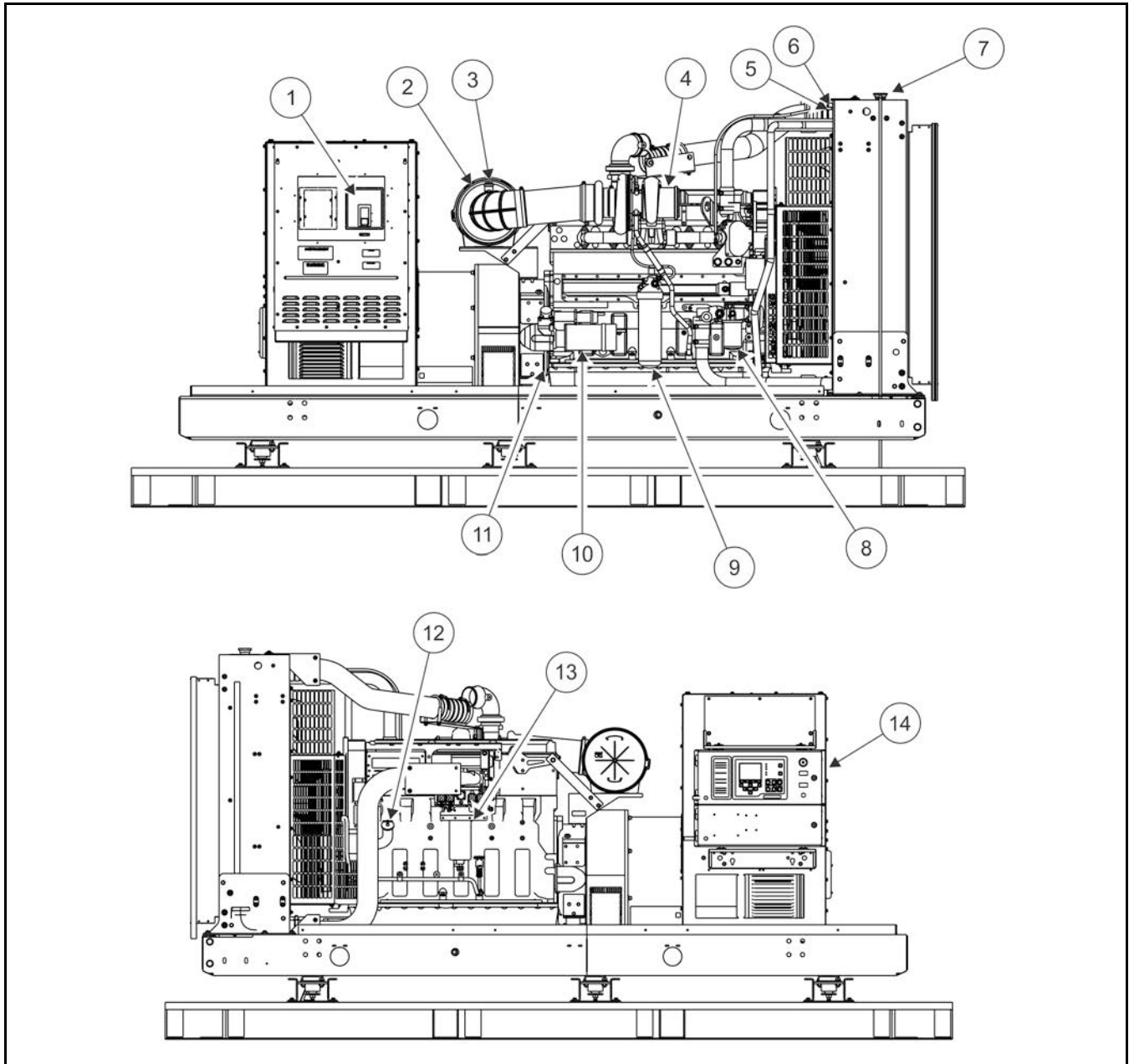

No	Description	No	Description
1	Circuit Breaker Lever	8	Fuel/Water Separator
2	Air Cleaner	9	Oil Filter
3	Service Indicator	10	Starter
4	Turbo Out Connection	11	Coolant Heater (not pictured)
5	Coolant Level Sight Glass (not pictured)	12	Oil Fill
6	Coolant Level Sensor (not pictured)	13	Fuel Filter
7	Coolant Fill	14	Control - Side Mount

FIGURE 2. TYPICAL GENERATOR SET COMPONENT LOCATIONS

3.2.1 Engine Components

For additional engine specific information, refer to the relevant engine manual listed in the Related Literature section.

TABLE 1. ENGINE COMPONENTS

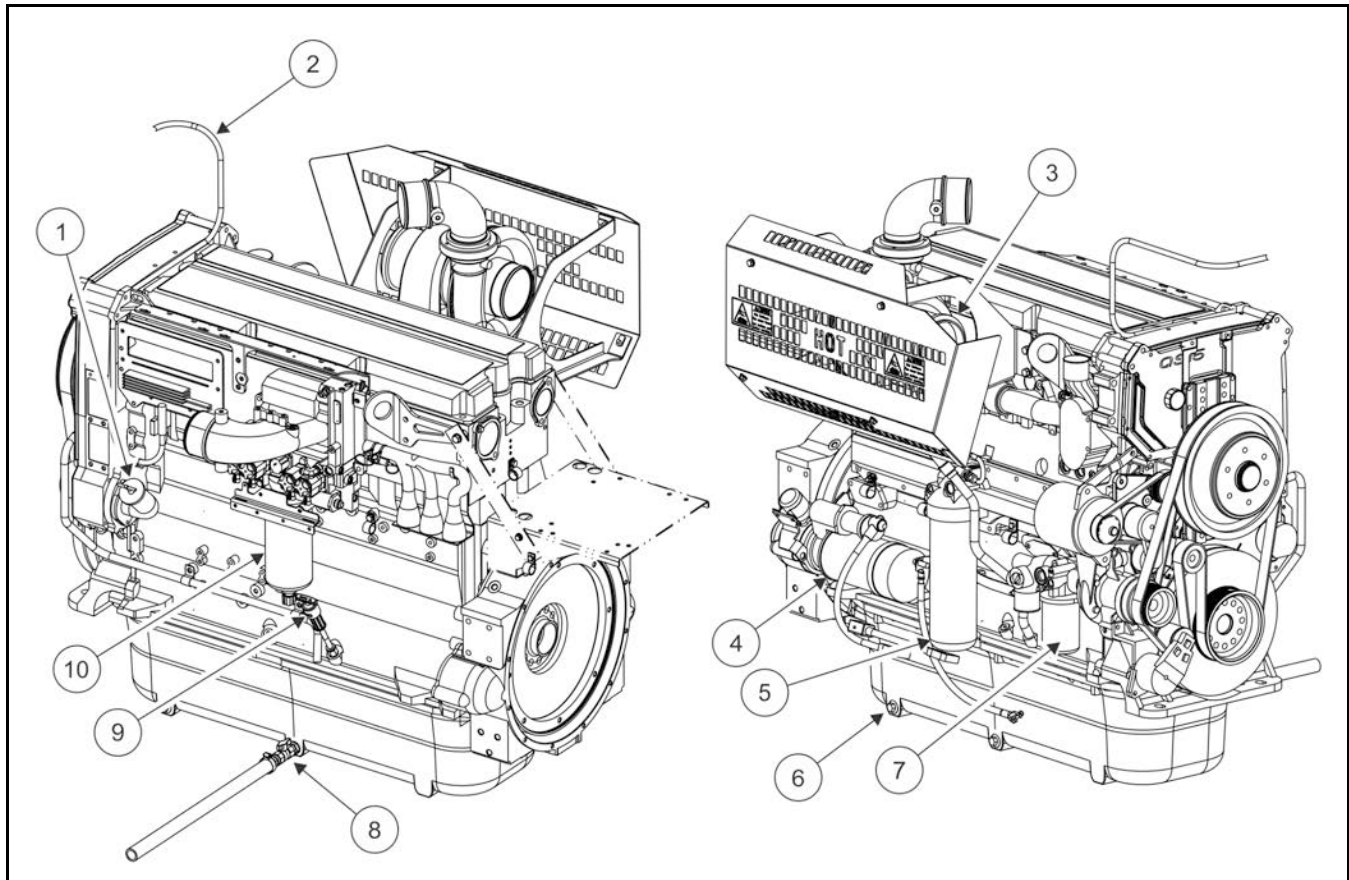

No	Description	No	Description
1	Oil Fill	6	Engine Oil Heater
2	Wiring Harness (Coolant Level Sensor)	7	Fuel/Water Separator
3	Turbo Out Connection	8	Oil Drain Shutoff Valve
4	Starter	9	Oil Dipstick
5	Oil Filter	10	Fuel Filter

3.3 Generator Set Performance Data

3.3.1 Engine Fuel Consumption

TABLE 2. FUEL CONSUMPTION (L/HR) AT 1800 RPM (60 HZ)

Model	DFEJ	DFEK
-------	------	------

Engine	QSX15-G9	QSX15-G9
Engine Performance Data at 60Hz ¹	114	130
1. Standby/Full Load 0% load will consume less than 100% load Refer to Data Sheets for other applications. In line with the CPG policy of continuous improvement, these figures are subject to change.		

TABLE 3. FUEL CONSUMPTION (GAL/HR) AT 1800 RPM (60 HZ)

Model	DFEJ	DFEK
Engine	QSX15-G9	QSX15-G9
Engine Performance Data at 60Hz ¹	30.1	34.4
1. Standby/Full Load 0% load will consume less than 100% load Refer to Data Sheets for other applications. In line with the CPG policy of continuous improvement, these figures are subject to change.		

3.3.2 Acoustic Information

3.3.2.1 Acoustic Information (1800 RPM)

TABLE 4. ACOUSTIC DATA (1800 RPM)

Model	DFEJ	DFEK
Engine	QSX15	QSX15
Standard, Unhoused ² - Infinite Exhaust	118	119
F183 Residential Muffler - Mounted Muffler	119	119
F200 Weather - Mounted Muffler	116	118
F201 Quiet Site II First Stage - Mounted Muffler	115	116
F202 Quiet Site II Second Stage - Mounted Muffler	104	104
1. Sound levels are subject to instrumentation, measurement, installation, and manufacturing variability 2. Sound data with remote-cooled generator sets are based on rated loads without cooling fan noise 3. Sound levels for aluminum enclosures are approximately 2 dB(A)s higher than listed sound levels for steel enclosures 4. Sound data for generator set with infinite exhaust do not include exhaust noise 5. Data is based on full rated load with standard radiator-cooling fan package 6. Sound Power Levels per ISO 3744 and ISO 8528-10, as applicable 7. Reference power = 1 pw (10 ⁻¹² W)		

3.4 Air Cleaner

An air cleaner includes an element that must be replaced periodically. Some air cleaners include a service indicator that indicates when an air cleaner element is dirty and must be replaced.

3.4.1 Normal Duty Air Cleaner

See the System Options section for information on the optional heavy duty air cleaner.

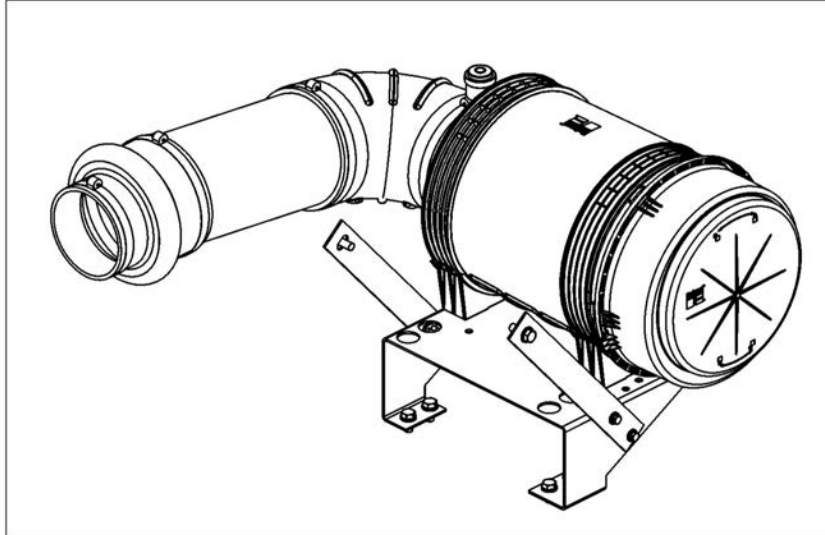

FIGURE 3. NORMAL AIR CLEANER ASSEMBLY

3.5 System Options

3.5.1 AC Distribution Panel

⚠ WARNING

Electric Shock Hazard

Voltages and currents present an electrical shock hazard that can cause severe burns or death. Receptacles J1 through J4 are GFCI protected and must not be used by service personnel as a power source for tools or lighting.

NOTICE

Make sure that all circuit breakers are in the OFF position before applying power to the AC distribution panel. Other options may require additional installation before connecting to power.

NOTICE

When the generator set contains the fuel transfer pump option, power to the AC distribution panel must be fed from a transfer switch and step-down transformer to maintain 120V power to the pump when utility power is interrupted. If the transfer pump option is not installed, power to the AC distribution panel can be fed from a non-emergency source. (Other optional features connected to the AC distribution panel are not needed for generator set operation.)

The AC distribution panel provides a centralized power source (120/220 VAC) for all optional enclosure features.

All connections to the AC distribution panel must comply with the National Electric Code and all applicable local codes and standards using 60 or 75 °C (140 or 167 °F) conductors.

The AC distribution panel is powered with a 100 A, 120/240 VAC, single phase feeder. The 2 line conductors connect into the 100 A main breaker that is listed for #4 to 2/0 conductors, AL or CU when torqued to 5.6 Nm (50 in-lbs).

The neutral conductor connects into the neutral bus which is listed for #5 to 300KCMIL conductors, AL or CU when torqued to 28.4 Nm (21 ft-lbs).

The grounding conductor, if used, connects into the ground bar which is listed for #1 to 2/0 conductors, AL or CU when torqued to 23 Nm (17 ft-lbs).

The GFCI receptacle is a 120 VAC/20 A ground fault protected outlet that is for use by service personnel. It also supplies power to the external receptacle.

Receptacles J1 through J4 are for internal use only (not GFCI protected). They are 120 VAC/20 A outlets for optional enclosure features.

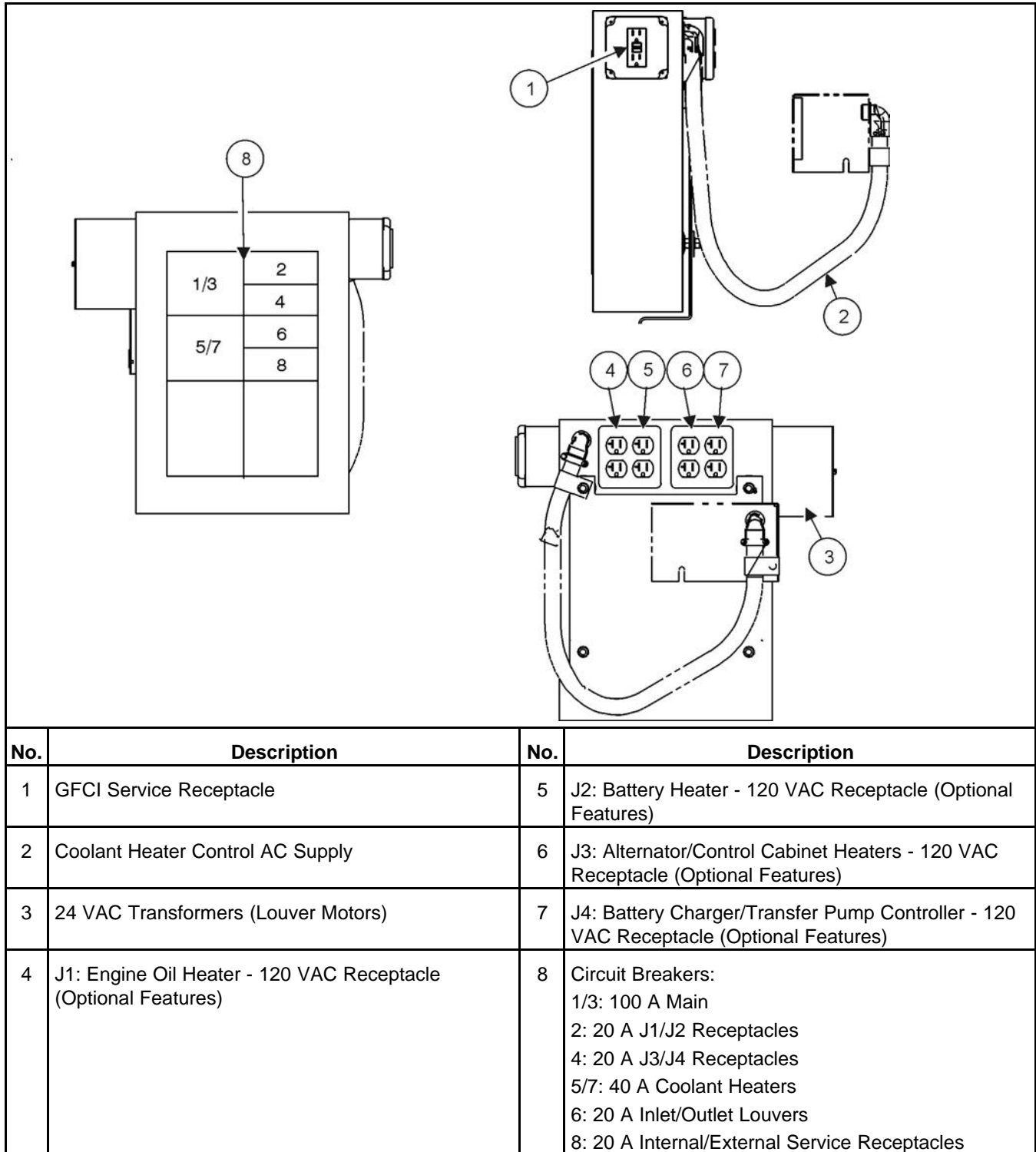

FIGURE 4. AC DISTRIBUTION PANEL FEATURES

3.5.2 Battery Charger - 15 Amp/12 Volt and 12 Amp/24 Volt

There are two types of 15/12-Amp PowerCommand battery chargers. All 15/12-Amp battery chargers have a 20 Amp DC circuit breaker switch on the front of the battery charger. The 120, 208, and 240 VAC battery chargers include two 10 Amp AC circuit breaker switches, all other models include two AC fuse holders.

Refer to the battery charger Owner Manual (901-0107) for more information.

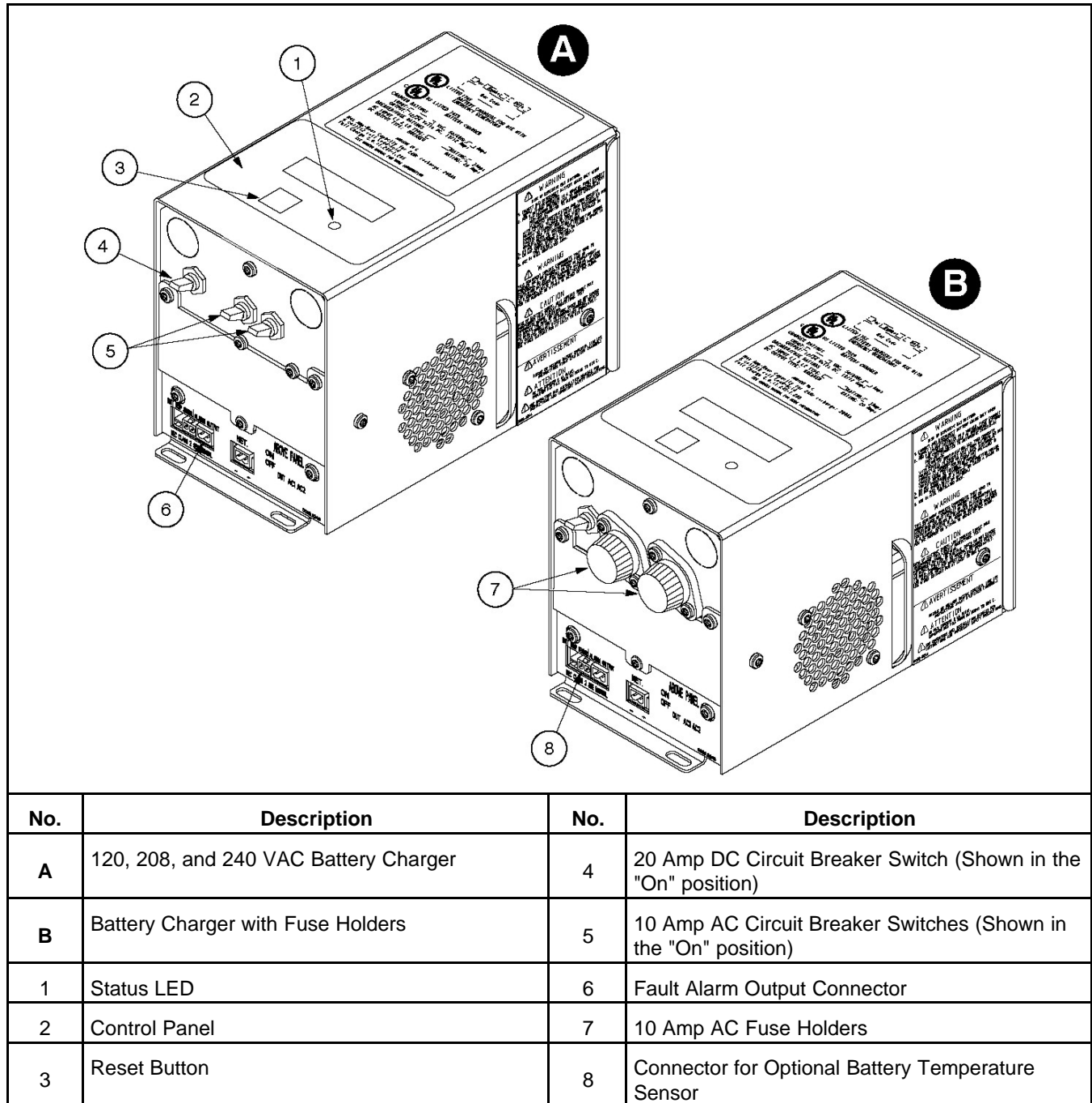

FIGURE 5. 15/12-AMP POWERCOMMAND BATTERY CHARGERS

3.5.2.1 Battery Charger Control Panel

The 15/12-amp charger control panel includes a digital display, a Reset button, and an LED status indicator.

- The 2-line x 16-character digital display displays menus and faults.
- The Reset button is used to select menu options and to clear fault messages.
- The status LED displays the appropriate color for the following conditions.
 - **Green** - On solid indicates unit is charging.
 - **Amber** - On solid indicates equalizing.
 - **Red** - On solid indicate a fault condition. The fault number is shown on the digital display.

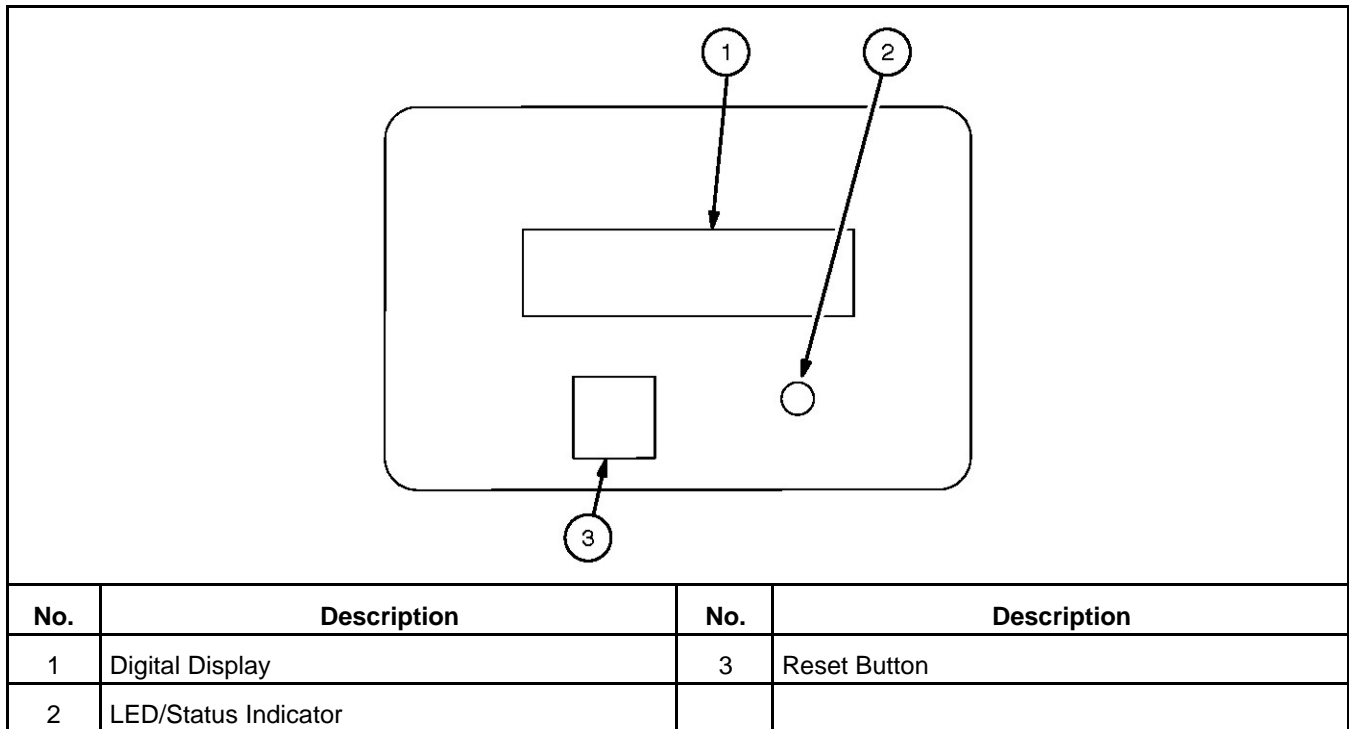

FIGURE 6. CONTROL PANEL

3.5.2.2 Battery Charger Configuration

The **RESET** button on the control panel is used to configure the battery charger. More information on the Setup menus is included in the Battery Charger Operator Manual (901-0107).

- **Battery Voltage and Type** - The battery charger must be correctly configured, using the Setup menus, for the correct battery voltage and type before it is connected to the battery. The battery voltage can be set for 12 or 24 VDC (default = 12 VDC). The battery type can be set for Lead-Acid, Gel, or AGM batteries (default = Lead-Acid).

NOTICE

A factory installed battery charger is set up for the proper DC battery voltage requested on the production order, with the Lead-Acid battery type selected as the default.

- **Float Voltage** - Various float voltages can be configured using the Setup menus. Consult your battery datasheet for the best possible choice.
- **Battery Equalization** - Battery equalization is available for Lead-Acid batteries that are completely charged, using the Equalize Battery screen in the Setup menus. When battery equalization is in process, the LED status indicator turns amber.

3.5.2.3 Battery Temperature Sensor

A connector for the battery temperature sensor option is located on the front of the battery charger. When used to monitor battery temperature, this sensor is connected from the battery charger to the positive terminal of the battery. A fault message (fault code 2263) is displayed if the battery temperature is too high (reaches 55 °C [131 °F]).

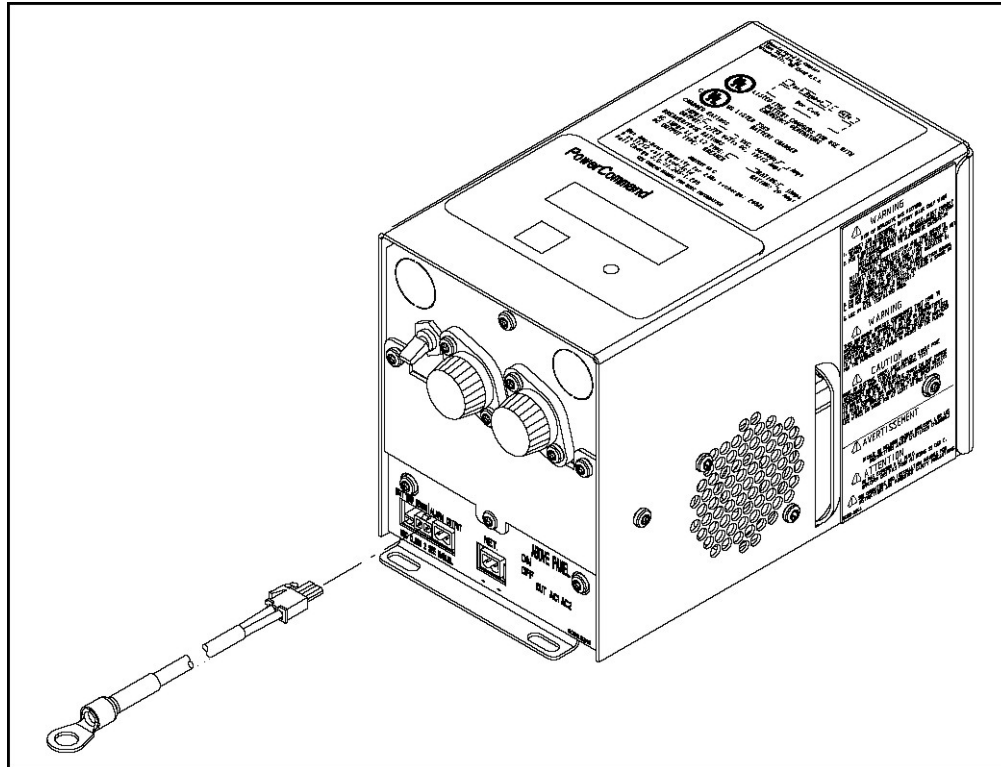

FIGURE 7. TEMPERATURE SENSOR

3.5.3 Circuit Breaker

A circuit breaker is used to prevent the generator from being overloaded.

A line circuit breaker is mounted in the generator output box. If the load exceeds the circuit breaker current rating, the line circuit breaker will open, preventing the generator from being overloaded. If the circuit breaker trips, locate the source of the overload and correct/eliminate the fault. Manually reset the breaker. Clear any fault messages and when safe to do so, reconnect the load to the generator.

3.5.4 Day Tank

For installations that include a fuel day tank, check the liquid level gauge to make sure an adequate amount of fuel is maintained.

Some day tanks include a day tank control. A typical day tank control includes an On/Off switch, a Test/Reset switch, circuit breakers, and status indicator lights. Make sure the control is plugged into an AC outlet.

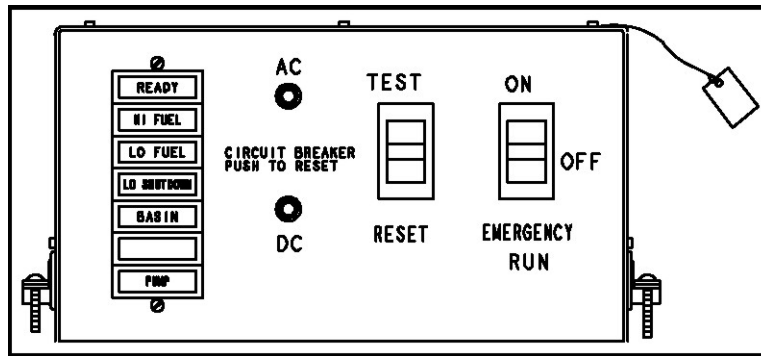

FIGURE 8. TYPICAL DAY TANK CONTROL

3.5.4.1 Day Tank Controller Operation

NOTICE

When power is applied to the control or is restored after a power interruption, the control will automatically go to the power on mode (functions the same as pressing the ON switch). The pump will start if the control detects low fuel in tank.

1. Press the control ON switch for automatic operation. The green PUMP light will come on and the pump will fill the tank. The level of fuel in the tank will be automatically kept between a set of pump-on and pump-off float gauge.
2. When filling an empty tank, the red CRITICAL LOW FUEL and LOW FUEL lights will come on when the control switch is pushed to the ON position. This is normal. The red lights will turn off as the tank is filled.
3. The green PUMP light indicates when the pump is running. It will come on and off as fuel is pumped to maintain the proper level in the tank.

3.5.5 Enclosures

Enclosed generator sets can require optional features to be electrically connected during installation.

NOTICE

Use flexible conduit and stranded conductors for connections. Solid copper wire may break during generator set operation.

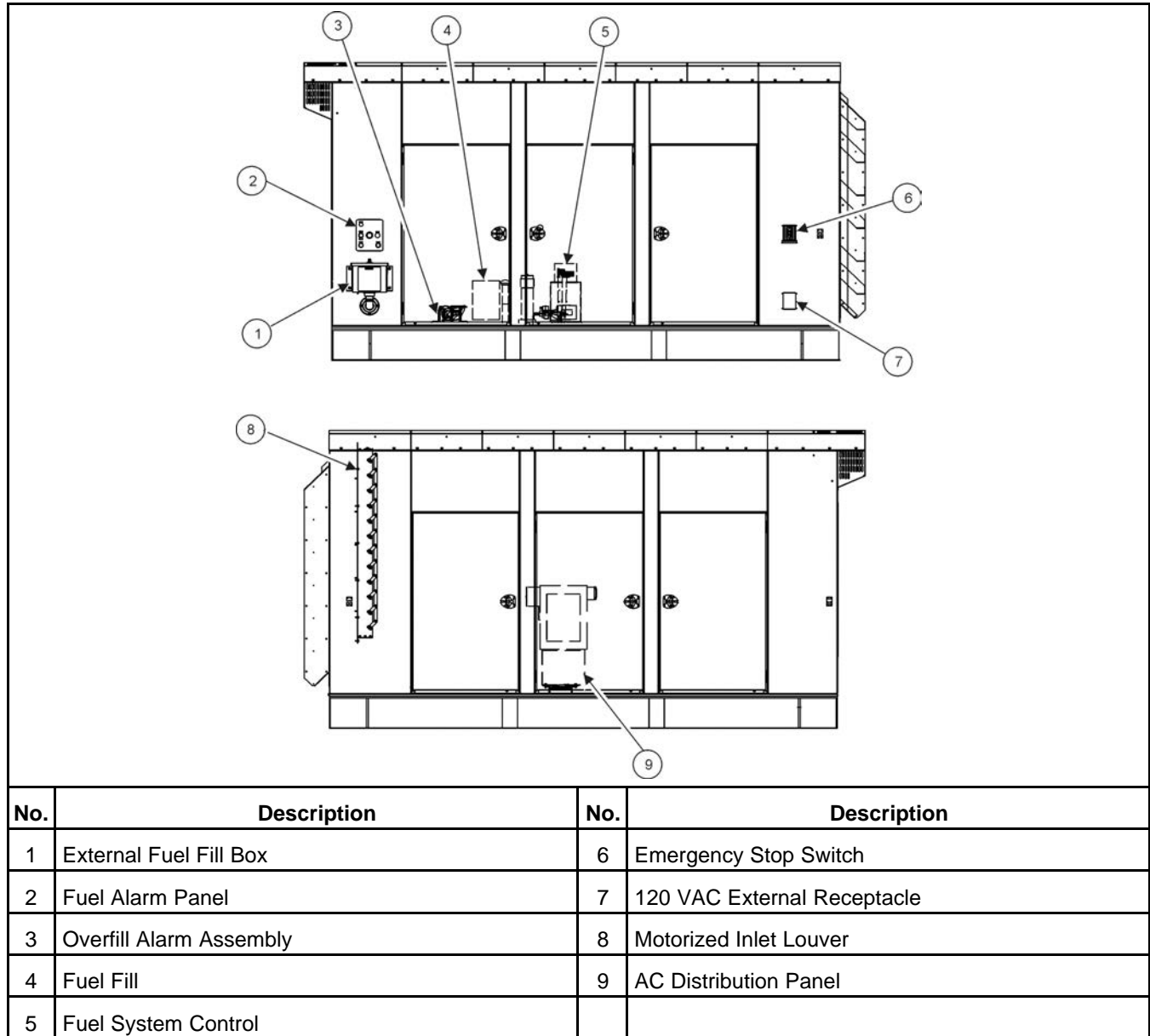

FIGURE 9. TYPICAL OPTIONAL ENCLOSURE FEATURES

3.5.6 Emergency Stop DC Circuit Breaker

The emergency stop DC circuit breaker protects the generator set control circuits from shorts to ground. Position the switch to **OFF** in an emergency and to **ON** when all necessary repairs to the generator set and connected equipment have been made.

3.5.7 External Receptacle

The external receptacle is located on the outside of the enclosure and provides shore power at 20 A, 120 VAC. With the AC distribution panel provided, this receptacle is GFCI protected. If power to the external receptacle is lost, reset the GFCI receptacle that is mounted to the side of the AC distribution panel.

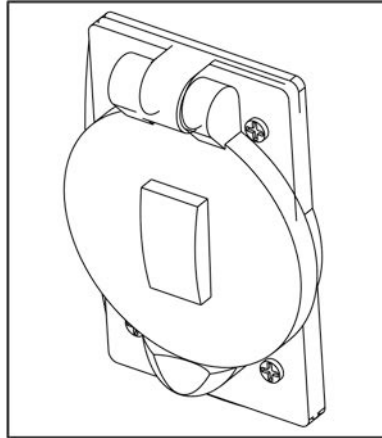

FIGURE 10. ENCLOSURE EXTERNAL RECEPTACLE

3.5.8 Fuel Transfer Pump

NOTICE

Damage to the fuel transfer pump can occur if the pump operates with no fuel in the supply tank. Do not connect AC power to the fuel transfer pump control without having fuel in the supply tank.

NOTICE

Power to the fuel transfer pump must be fed from a transfer switch and step-down transformer to maintain 120V power to the pump when utility power is interrupted. Power must be supplied to the transfer pump during the time the generator set is running or not running.

The fuel pump/controller is pre-wired and ready to connect to a 120 VAC source.

NOTICE

When power is applied to the control or is restored after a power interruption, the control will automatically go to the power on mode (functions the same as pressing the ON switch). The pump starts if the control detects low fuel in the sub-base tank.

A fuel transfer pump and control are available when a sub-base fuel tank is provided. The automatic control operates the fuel pump to maintain a reservoir of fuel in the sub-base tank.

The fuel transfer pump has a maximum inlet restriction capability of 16 inch Hg, which is approximately equivalent to 20 feet of diesel.

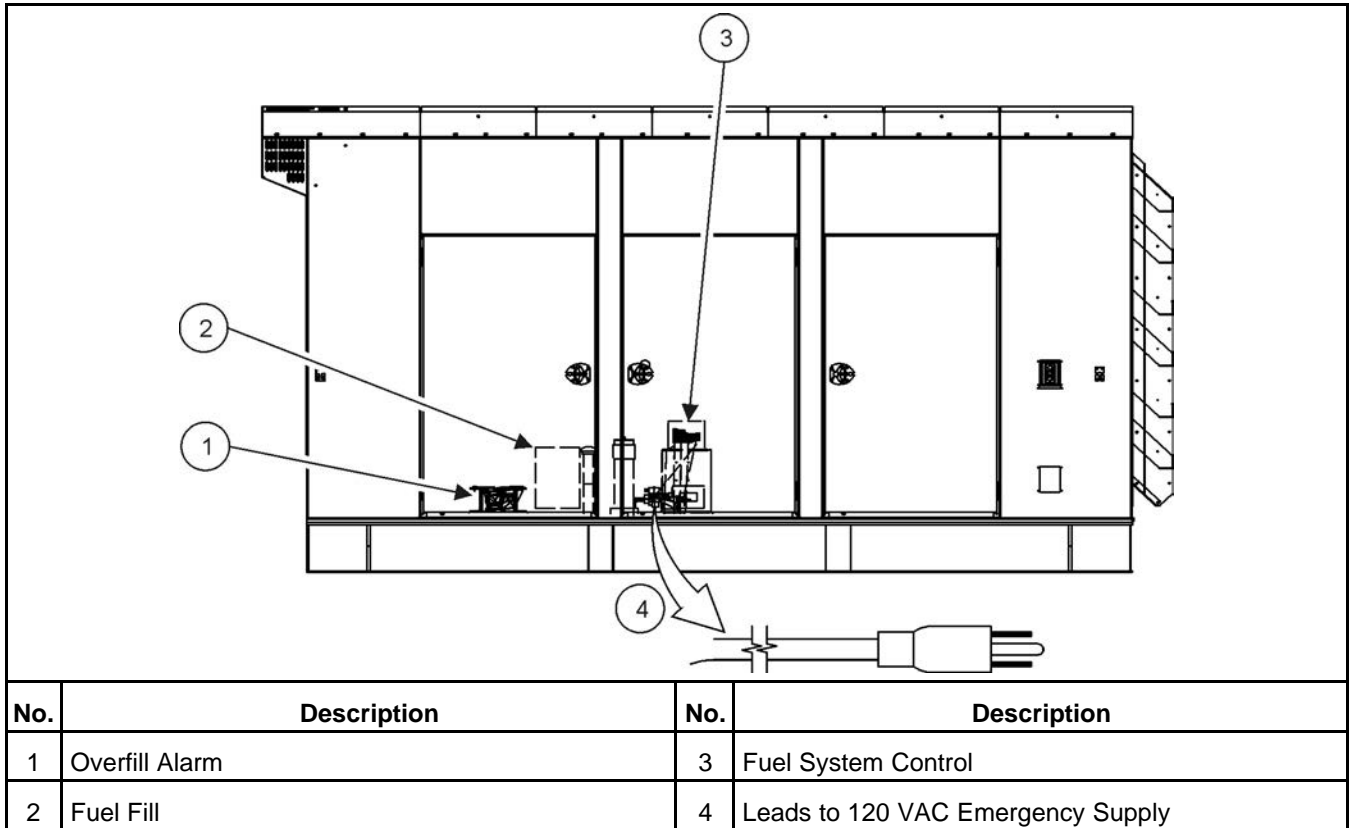

FIGURE 11. FUEL TRANSFER PUMP/CONTROL LOCATION

3.5.8.1 Control Panel Switches and Indicators

The transfer pump control includes the following indicators.

NOTICE

All red color lamps indicate a fault condition.

- FUEL LEVEL (green): Indicates in percent the amount of fuel that is contained in the sub-base tank.
- HIGH FUEL (red): Indicates that the fuel has reached an abnormally high level (approximately 90%). This indicates a possible failure of the "pump-off" float gauge in the sub-base tank. The lamp turns off when the fuel level drops back to normal.

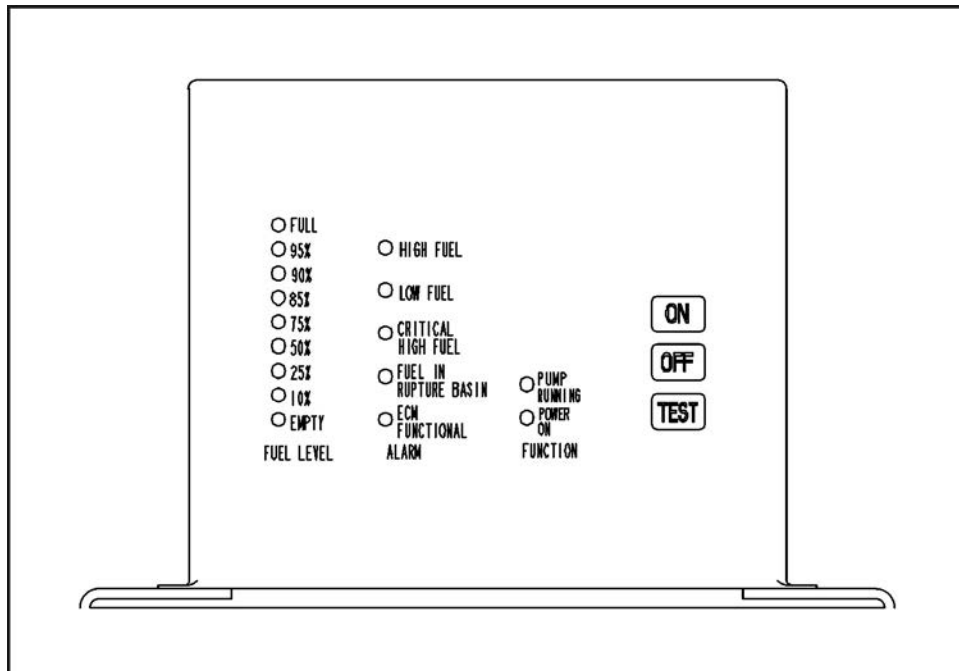

FIGURE 12. TRANSFER PUMP CONTROL FRONT PANEL

- **LOW FUEL (red):** Indicates that the fuel level has dropped below low fuel level (approximately 62%). This warning enables the operator time to react to a potential problem before low fuel shutdown occurs. It indicates a possible empty main fuel tank, fuel line restriction, pump failure, or failure of the float gauge.
- **CRITICAL LOW FUEL (red):** Indicates that the fuel level has dropped to tank bottom. This warning enables the operator time to shut down generator set before fuel runs out, preventing loss of prime or engine damage. It indicates a possible empty main fuel tank, fuel line restriction, pump failure, or failure of the float gauge.

The control should be wired to shut down the generator set (optional) as continued operation will allow air to enter the engine injection pump necessitating bleeding to restart the engine. The control will reset after restoring the tank fuel level. This will also restore engine operation if the tank control has been connected to shut down the engine.

NOTICE

Continued operation with a CRITICAL LOW FUEL fault can lead to a low fuel shutdown if the fuel level float switch fails.

- **FUEL IN RUPTURE BASIN (red):** Indicates that the fuel has flooded the safety basin surrounding the fuel tank. The basin float switch turns off the fuel pump. The pump cannot function again until the basin is drained of fuel. Possible cause, leak in fuel tank.
- **PUMP (green):** Indicates that the fuel pump is running. It will come on and go off as fuel is pumped to maintain the fuel tank level.
- **ECM FUNCTIONAL (green):** Indicates no faults are detected within the control circuitry (including float gauge). If a fault occurs, the lamp will go out and de-energize the control relay. It is suggested that the customer wire to the normally closed contact to provide a signal if a fault does occur.
- **POWER ON (green):** Indicates that AC power is available to the control.

The transfer pump control includes the following switches.

- **ON:** This pushbutton activates the control after the OFF pushbutton has been pressed.

- **OFF:** This pushbutton disables the control for routine maintenance to the tank system without disrupting the control. **NOTE:** This also de-energizes the ECM FUNCTIONAL relay which will activate a customer alarm wired to this relay.
- **TEST:** This pushbutton will test all front panel lamps for three seconds and activate pump/motor for as long as the button is pressed. All alarm relays will not activate but will maintain their original state.

3.5.9 Generator Set Alarm

The generator set alarm is located on the control panel. It flashes yellow when active and is also an audible warning, which turns off when the fault is cleared.

3.5.10 Heaters

3.5.10.1 Heater Supply and Isolation

A power supply is required for the operation of any system heaters.

NOTICE

It is the sole responsibility of the customer to provide the power supply and the means to isolate the AC input to the terminal box. Cummins Power Generation accepts no responsibility for providing the means of isolation. Contact your distributor for more information.

NOTICE

This disconnecting device is not provided as part of the generator set.

3.5.10.2 Alternator Heater

An alternator heater is used to help keep the alternator free of condensation when the generator set is not running. During cool and humid conditions, condensation can form within an alternator, creating flashing and shock hazards.

3.5.10.3 Control Box Heater

A control box heater is used to keep the control free of condensation and to make sure the temperature inside of the control box is within recommended guidelines for proper control board operation. It protects the components when the generator set is subjected to varying ambient air conditions during extended periods of non-use.

3.5.10.4 Coolant Heater

NOTICE

**Operating the heater or heaters when the coolant system has been drained, or there is a suspicion that the coolant is frozen, can result in equipment damage.
Always make sure the coolant is not frozen and the radiator is filled to the recommended level before energizing the heater, or heaters.**

A coolant heater keeps the engine coolant warm when the engine is shut down. It heats and circulates the coolant within the engine. This reduces start-up time and lessens engine wear caused by cold starts. It is electrically operated and thermostatically controlled.

3.5.10.5 Oil Pan Heaters

Oil pan heaters keep the engine oil warm while the engine is shut down, keeping it ready for easier startup in cold weather and reducing wear and tear on the engine by providing better lubrication upon startup.

3.5.11 Heavy Duty Air Cleaner

A heavy duty air cleaner is used in dusty environments.

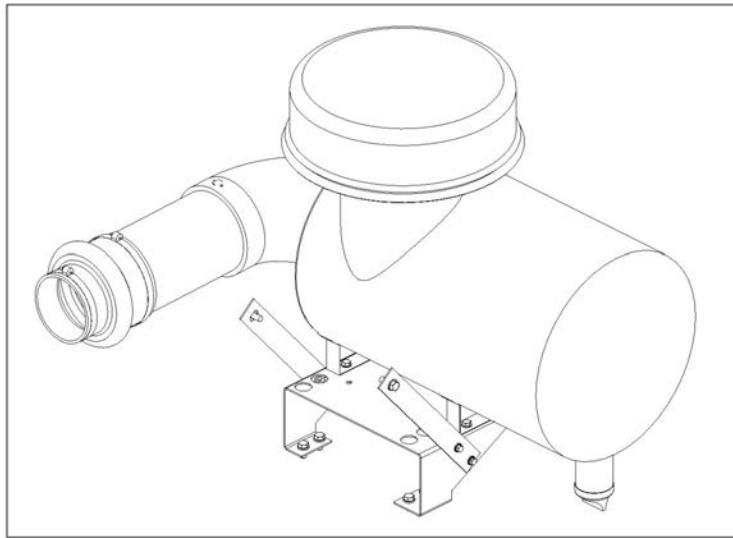

FIGURE 13. HEAVY DUTY AIR CLEANER ASSEMBLY

3.5.12 Overfill Alarm

The overfill alarm indicates that the fuel has reached an abnormally high level (the alarm sounds at approximately 90% of fuel tank capacity). When this happens, immediately stop adding fuel. The horn can be turned off by pressing the reset button.

NOTICE

The automatic shutoff of a fuel truck nozzle is approximately 95% of fuel tank capacity.

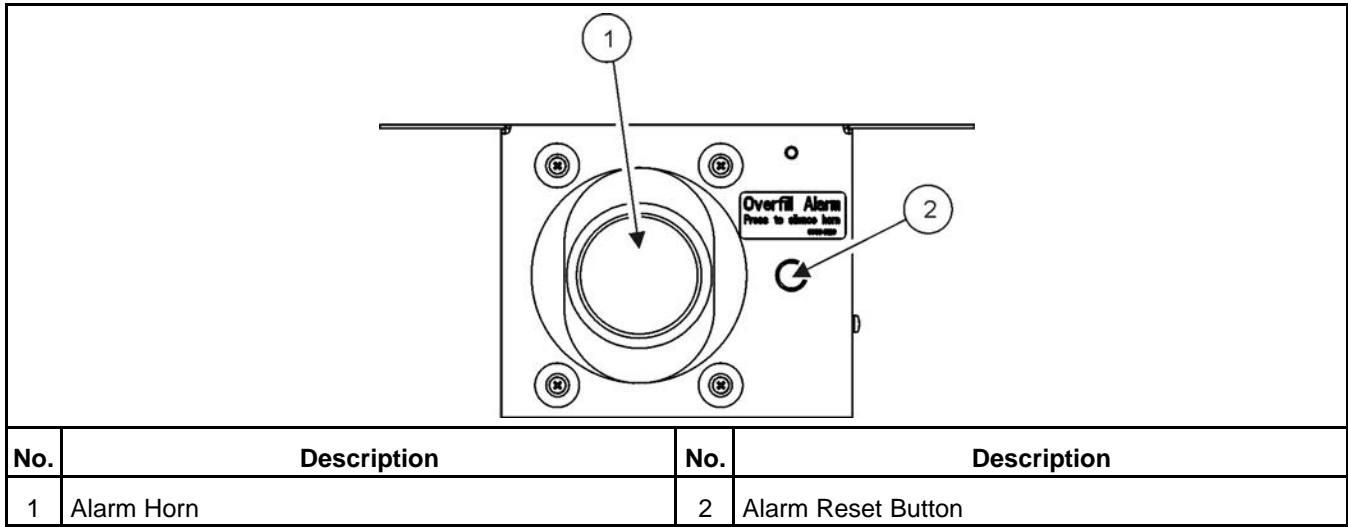

FIGURE 14. OVERFILL ALARM PANEL

3.5.13 Pyrometers - Engine Exhaust

A pyrometer measures engine exhaust gas temperature. A separate temperature meter is used to monitor each exhaust outlet elbow.

3.5.13.1 Pyrometer

A pyrometer measures engine exhaust gas temperature.

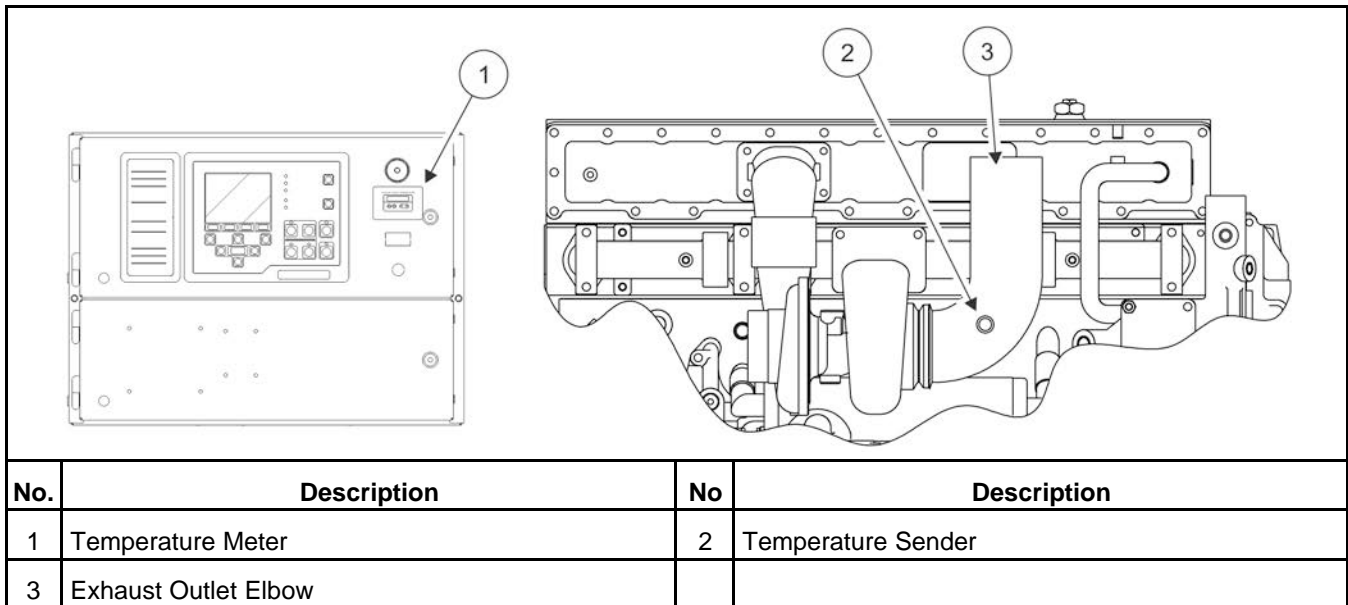

FIGURE 15. PYROMETER LOCATION

3.5.14 Sensors

Various generator set parameters are measured by sensors, and the resulting signals are processed by the control board.

Typical sensors include, but are not limited to:

- Oil pressure
- Coolant level
- Fuel level
- Coolant temperature
- Lube oil temperature
- Alternator temperature

This page is intentionally blank.

4 Control System - PowerCommand 2.3

4.1 Control System Description

The control system is used to start and stop the generator set from the display screen in either Manual or Auto mode. It is suitable for standalone or paralleling generator sets in both standby and prime-power applications, providing full generator set monitoring capability and protection. It monitors the engine for temperature, oil pressure and speed, and provides voltage and current metering. In the event of a fault the unit indicates the fault type and automatically shuts down the generator set on critical faults.

All indicators, control buttons and the display screen are on the face of the operator panel as illustrated in the following figure.

There are two fault level signals generated by the control system as follows:

- **Warning:** signals an imminent or non-critical fault for the engine. The control provides an indication only for this condition.
- **Shutdown:** signals a potentially critical fault for the engine. The control immediately takes the engine off-load and automatically shuts it down.

The standard control system operates on 12 VDC or 24 VDC battery power. The auxiliary equipment operates on LV AC power. The history data is stored in non-volatile memory and is not deleted if battery power is lost.

4.1.1 Control System Panel

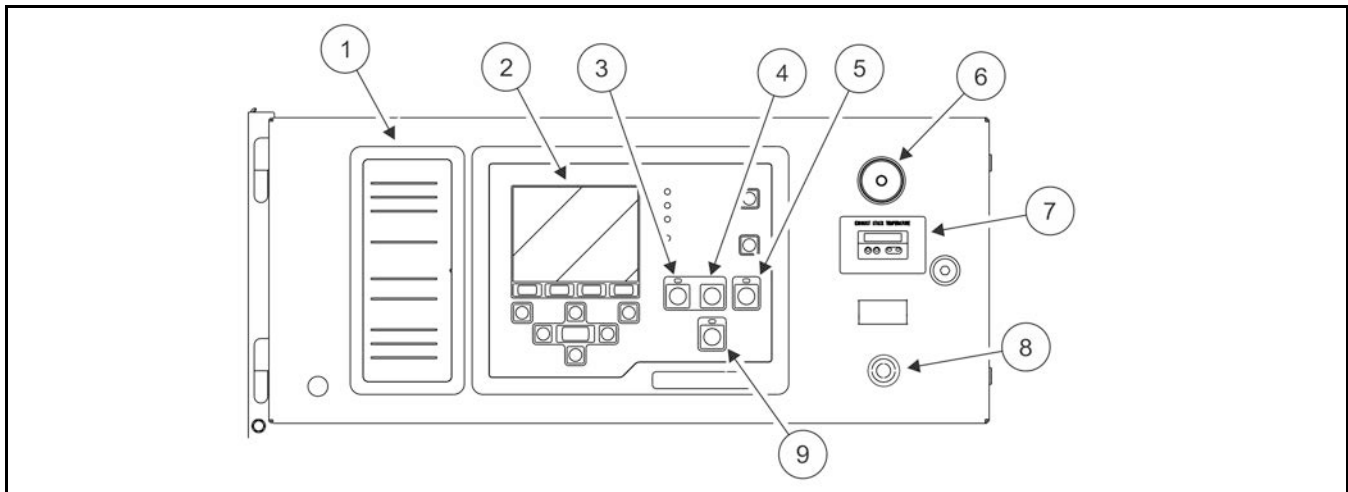

No.	Description	No.	Description
1	Bargraph Panel	6	Emergency Stop
2	Operator Panel	7	Exhaust Temperature Meter
3	Manual Mode Button	8	Generator Set Alarm
4	Start Mode Button	9	Stop Mode Button
5	Auto Mode Button		

FIGURE 16. CONTROL SYSTEM PANEL

4.1.2 Operating Modes

The PowerCommand® 3.3 control is operated by the **Start/Stop/Manual/Auto** buttons on the Operator Panel.

NOTICE

If the Mode Change access feature is enabled, a password is required to use these buttons to change the mode of operation. Contact your authorized distributor for options.

4.1.2.1 Stop Button



Press this button to put the generator set into the Off mode. This disables Auto and Manual modes. The green lamp above this button lights when the generator set is in the Off mode.

If the generator set is running, in either Manual or Auto mode, and the **Stop** button is pressed, the engine shuts down.

Refer to the Selecting Operating Modes section for more information on stopping in Auto or Manual mode.

NOTICE

If possible, hot shutdown under load should be avoided to help prolong the reliability of the generator set.

4.1.2.2 Manual Button



Press this button to put the generator set into the Manual mode. The **Start** button must then be pressed within ten seconds. Failure to do this results in the control mode defaulting, putting the generator set into the Off mode.

The green lamp above this button is lit when the generator set is in Manual mode.

NOTICE

If the Mode Change access password feature is enabled, the password must be entered before pressing the Start button. See the Passwords and Mode Change section.

4.1.2.3 Start Button



When the **Manual** button is pressed, this **Start** button must be pressed within ten seconds to start the generator set. The generator set starts up normally but without the Time Delay to Start.

In other modes, this button has no effect.

NOTICE

If the Start button is not pressed within the ten seconds of pressing the Manual button, the generator set mode changes to the Off mode automatically.

4.1.2.4 Auto Button



Press this button to put the generator set into the Auto mode. In this mode, the generator set is controlled by a remote switch or device (e.g. transfer switch).

The green lamp above this button lights when the generator set is in Auto mode.

4.1.2.5 Battle Short Mode

⚠ WARNING

Automated Machinery

Battle Short mode overrides some parameters of generator set control. Unmonitored generator sets can cause a fire or electrical hazard, resulting in severe personal injury or death.

Make sure that the operation of the set is supervised during Battle Short operation.

Battle Short mode is not a distinct mode of operation. The PowerCommand® control is still in the Off, Manual, or Auto mode while Battle Short mode is active. The PowerCommand® control still follows the appropriate sequence of operation to start and stop the generator set. Battle Short mode is a generator set mode of operation that prevents the generator set from being shut down by all but a few, select, critical shutdown faults.

The purpose of Battle Short mode is to satisfy local code requirements, where necessary. To use this feature, the necessary software must be installed at the factory when the PowerCommand® control is purchased. Only authorized service personnel can enable this feature. When shipped from the factory, this feature is disabled.

NOTICE

The Battle Short feature must be enabled or disabled using the InPower service tool.

This feature must only be used during supervised, temporary operation of the generator set. The faults that are overridden when in Battle Short mode can affect generator set performance, or cause permanent engine, alternator or connected equipment damage.

NOTICE

If this mode of operation is selected, the protection of load devices will be disabled. Cummins will not be responsible for any claim resulting from the use of this mode.

NOTICE

All shutdown faults, including those overridden by Battle Short, must be acted upon immediately to ensure the safety and well-being of the operator and the generator set.

Battle Short is turned on or off with an external switch connected to one of the two customer configured inputs or a soft switch on the operator panel.

When enabled, **Battle Short** switch input can be set using a Setup menu. To turn Battle Short mode on using the soft switch in the operator panel, **Battle Short** must be set to "Operator Panel" and enabled using the InPower service tool (default is Inactive).

When Battle Short mode is enabled, the Warning status indicator lights and code "1131 – Battle Short Active" is displayed.

When Battle Short mode is enabled and an overridden shutdown fault occurs, the shutdown lamp remains lit even though the set continues to run. "Fault code 1416 – Fail to Shutdown" is displayed. If the fault is acknowledge, the fault message is cleared from the display but remains in the Fault History file as long as Battle Short mode is enabled.

Battle Short is suspended and a shutdown occurs immediately if any of the following critical shutdown faults occur:

- Speed Signal Lost (Loss of Speed Sense) - Fault code 121
- Overspeed - Fault code 234
- Local Emergency Stop - Fault code 1433
- Remote Emergency Stop - Fault code 1434
- Excitation Fault (Loss of Voltage Sense) - Fault code 2335

Or

The Battle Short feature is disabled after an overridden shutdown fault occurred while in Battle Short mode. Fault code "1123 – Shutdown After Battle Short" is then displayed.

4.1.3 Power On and Sleep Modes

The operating modes of the control panel and operating software are Power On and Sleep.

Power On Mode

In this mode, power is continuously supplied to the control panel. The control's operating software and control panel lamps/graphical display remain active until the Sleep mode is activated.

Sleep Mode

Sleep mode is used to reduce battery power consumption when the control is not being used and it is in the Off or Auto mode. In this mode, the control's operating software is inactive and the lamps and graphical display on the control panel are all off.

When all conditions are met (i.e. no unacknowledged faults and the control is in the Off/Auto mode), the sleep mode activates after five minutes of keypad inactivity. This length of time is configurable.

To activate the control and view the menu display without starting the generator set, press any control button.

NOTICE

Sleep mode can be enabled/disabled. Contact your authorized distributor for options.

4.2 Operator Panel

[Figure 17 on page 41](#) shows the features of the operator panel. It includes lamp indicators, the graphical display with navigation soft keys used to navigate through the menus, and control mode buttons. This display panel enables the operator to look at the system status, adjust settings, and start and stop the generator set .

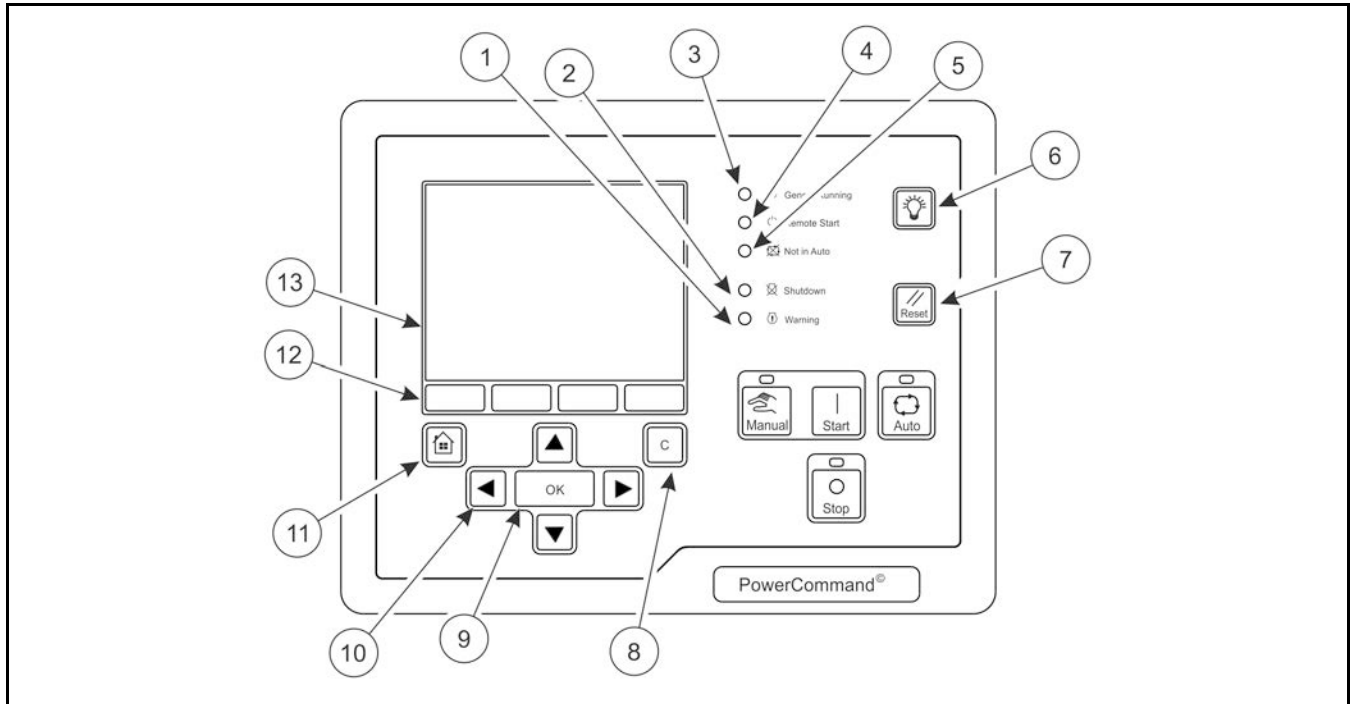

1	Indicator Lamp – Warning	8	Previous Menu Button (or Clear)
2	Indicator Lamp – Shutdown	9	Item Select Button (OK)
3	Indicator Lamp – Genset Running	10	Change Selection Buttons (Up, Down, Left, Right) (4)
4	Indicator Lamp – Remote Start	11	Home Button
5	Indicator Lamp – Not in Auto	12	Soft-key Buttons (for use with graphical display) (4)
6	Lamp Test Button	13	Graphical Display
7	Reset Button		

FIGURE 17. OPERATOR PANEL

4.2.1 Selection Buttons

Four momentary buttons are used to navigate and change the selection in the graphical display:

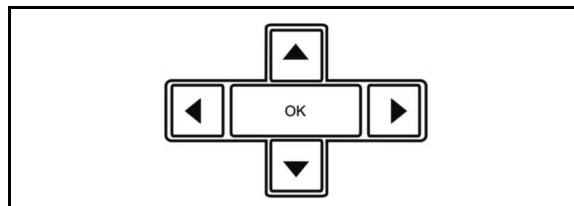

FIGURE 18. SELECTION BUTTONS

Press the **OK** button to select the item that is currently highlighted in the graphical display:

Item	Results of Pressing OK
Menu	Opens the sub-menu or screen
Parameter	Allows adjustment of the parameter (if possible) or prompts for a password
Adjusted Value	Saves the change
Action	The graphical display runs the action or prompts for a password

4.2.2 Default Settings

The operator panel can display SAE or Metric units of measurement and should be set during the initial setup of the generator set. Only trained and experienced personnel are allowed to change the default setting. Contact your authorized distributor.

4.2.3 Lamp Indicators

4.2.3.1 Warning

This amber lamp is lit whenever the control detects a Warning condition. This lamp is automatically shut off when the Warning condition no longer exists.

4.2.3.2 Shutdown Status

This red lamp is lit when the control detects a Shutdown condition. The generator set cannot be started when this lamp is on. After the condition has been corrected, the lamp can be reset by first pressing the **Stop** button and then the **Reset** button.

4.2.3.3 Not in Auto

This red lamp is lit when the control is not in Auto.

4.2.3.4 Remote Start

This green lamp indicates the control is receiving a **Remote Run** signal. The **Remote Run** signal has no effect unless the generator set is in Auto.

4.2.3.5 Generator Set Running Lamp

The green lamp is lit when the generator set is running at, or near, rated speed and voltage. This is not lit while the generator set is warming up or cooling down.

4.2.4 Lamp (LED) Test Button

Press this button to test the lamps (LEDs). All of the lamps should turn on for five seconds.

Press and hold this for three seconds to turn on or off (to toggle) an external panel lamp.

4.2.5 Reset Button

Press this to reset any active faults.

If the condition(s) that caused an existing shutdown fault still exists, the generator set generates the fault again.

If the condition(s) that caused an existing warning fault still exists, the generator set generates the fault again, but the operator panel stops displaying it in the graphical display.

4.2.6 Graphical Display and Buttons

Figure 19 on page 43 shows the graphical display and the relevant menu selection buttons.

The graphical display is used to view menus of the menu-driven operating system. System messages (communication, event, and fault) are also shown on the display.

Four momentary soft-key buttons (item 5) are used to change menus, or pages within each screen. These selection buttons are “active” when any text or the up and down triangles (▲ and ▼ in Section 4) are displayed in the graphical display. Some sub-menus do not include any active buttons.

Use the graphical display to view event/fault information, status, screens, and parameters.

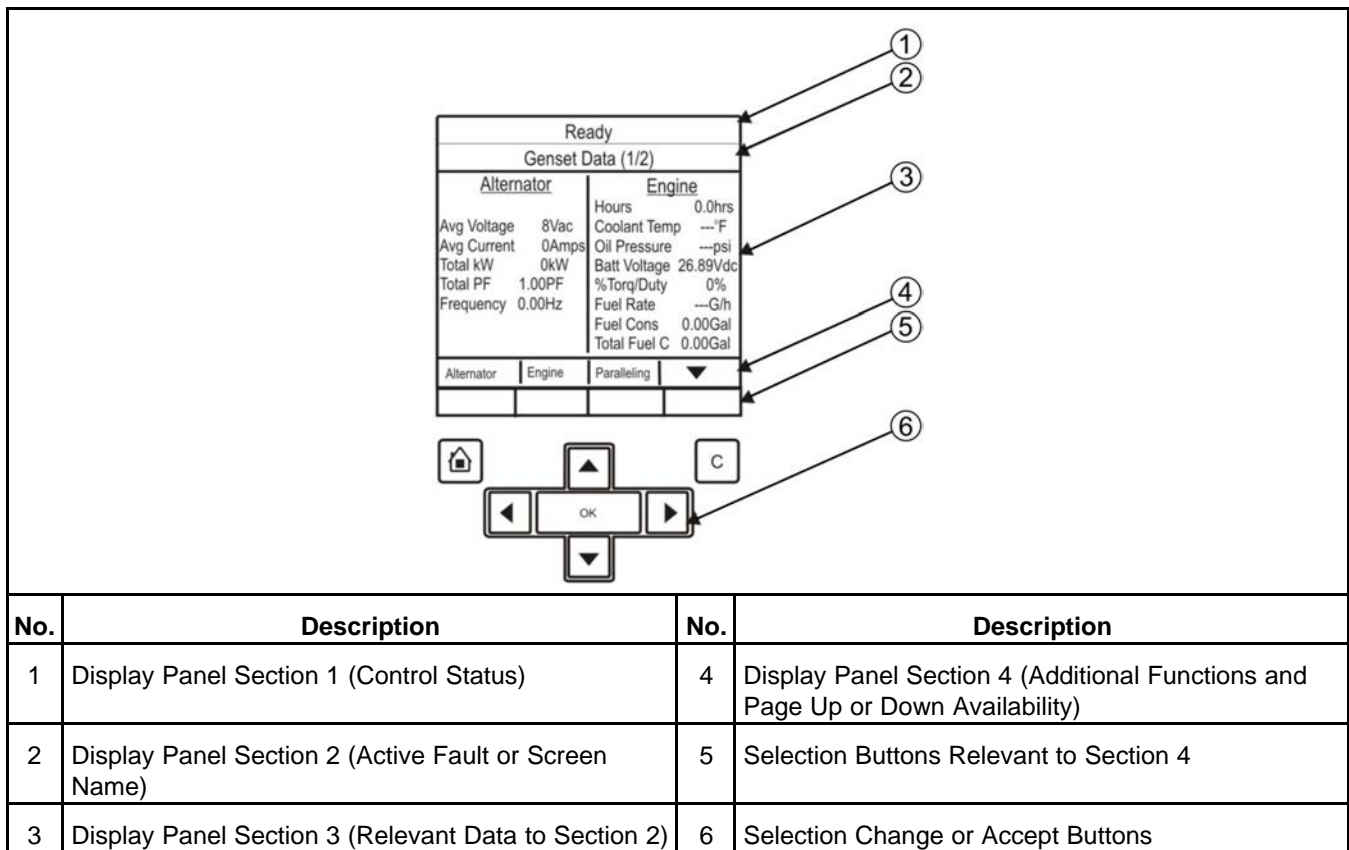

FIGURE 19. GRAPHICAL DISPLAY WITH TYPICAL SCREENSHOT

4.2.6.1 Section 1 - Control Status

Section 1 displays the status of the controller.

TABLE 5. CONTROL STATUS

Status	Description
Ready	This is the default state. The controller is ready to start the generator set, or it has started one of the start sequences but has not started the engine yet.
Starting	The controller is starting the engine in one of the start sequences, and the engine speed is greater than zero.
Idle Warmup	The controller is raising the engine speed to idle speed, or the engine is running at idle speed in one of the start sequences.
Rated Freq and Voltage	The controller is raising the engine speed to rated speed; the generator set is running at rated speed and voltage; or the controller has started one of the stop sequences but has not started reducing the engine speed yet.
Idle Cooldown	The controller is reducing the engine speed to idle speed, or the engine is running at idle speed in one of the stop sequences.
Stopping	The controller is stopping the engine, and the engine speed is still greater than zero.
Emergency Stop	There is an active shutdown fault.
Setup Mode	The controller is in Setup mode.
Wait to Powerdown	The controller is ready to enter Powerdown mode, but another device is sending a System Wakeup signal.
Off	The controller is in the process of entering power-down mode. The controller is performing some last-second checks.
Demo Mode	The controller is running a demonstration. Every screen is available in the demonstration, and any changes you make in the demonstration will have no effect on the controller. To end the demonstration, the operator panel must be turned off.

4.2.6.2 Section 2 - Active Fault or Screen Name

Section 2 displays the screen name and information about the last active shutdown fault. If there are no active shutdown faults, it displays the last active warning fault.

If there is an active fault, the operator panel displays the following information about it:

- Fault type
- Event/fault code
- Name of the controller that detected the fault (e.g., the engine ECM unit); this is blank if the controller detected the fault
- Fault name

If you press the **Reset** button, the operator panel stops displaying active warning faults, even if the condition(s) that caused the fault(s) has not been corrected. However, the Warning LED remains on.

The operator panel always displays any active shutdown faults, even if the **Reset** button is pressed.

TABLE 6. ACTIVE FAULT TYPES

Fault Type	Description
Warning	This is a warning fault. (See the Troubleshooting section.)
Derate	This is a derate fault. (See the Troubleshooting section.)

Fault Type	Description
Shutdown	This is a shutdown fault that initiates a Shutdown Without Cooldown sequence. (See the Troubleshooting section.)
Shutdown with Cooldown	This is a shutdown fault that initiates a Shutdown With Cooldown sequence.

4.2.6.3 Section 3 - Interactive Screen or Menu

Section 3 shows information relevant to Section 2. You can view the operating values for the generator set, navigate through screen and adjust parameters (if permitted).

The default screen is the Genset Data screen.

The following table explains how the operator panel displays when the value of a specific parameter is missing, unexpected, or outside the range allowed for the parameter.

TABLE 7. PARAMETER VALUES THAT ARE MISSING, UNEXPECTED, OR OUTSIDE THE RANGE ALLOWED

Operator Panel	Description
NWF	Network Failure - There is a PCCNet network failure or a CAN (ECM) failure
OORL	Out Of Range Low - The value is less than the lowest allowed value for this parameter
OORH	Out Of Range High - This value is greater than the highest allowed value for this parameter
-- -- --	This value is not applicable

4.2.6.4 Section 4 - Additional Functions Indicators

Section 4 indicates if additional information or further sub-menus are available by up or down arrows (▲ and ▼). If that particular page or menu has no additional information, then no arrow will be visible at this time.

For example if the graphical display is not big enough to display the screen at one time an up and/or down arrow (▲ and ▼) will be visible. Press the appropriate selection button beneath the graphical display to look at the previous or next page of information in that screen.

4.3 Fault Messages - PowerCommand 2.3

A Fault message is an indicator of a Warning or Shutdown condition. It includes the fault type (Warning or Shutdown), fault number, and a short description. It also includes where the fault occurred if the generator set control did not detect the fault and is simply reporting the fault.

The Fault Codes - PowerCommand 2.3 section provides a list of the fault codes, types, messages displayed, and descriptions of the faults.

Active and acknowledged faults may be viewed in the Faults menu.

4.3.1 Fault Acknowledgement

Shutdown faults must be acknowledged after the fault has been corrected. If in Auto or Manual mode, the control must be set to Stop mode (Off). Faults are cleared from the control panel display by pressing the **Reset** button.

Faults are also acknowledged when in Auto mode and the remote start command is removed.

Faults are re-announced if they are detected again after being acknowledged.

4.4 Operator Panel - Initial Operator Menu

[Figure 20 on page 47](#) shows the initial menu which is displayed over two pages. Use the soft-key buttons below the up and down arrows (▲ and ▼) to toggle between the two pages.

Use the soft-key buttons below Genset, Alternator, or Engine to short-cut to those menus.

Pressing the **Home** button  from any screen will return the display to the main menu screens.

4.4.1 Initial Menu Data

This menu displays the information available through the menus.

TABLE 8. INITIAL DATA MENU

Name	Description	
History/About	Use this screen to view historical information about your generator set.	
Faults:	If there are no active Faults, these screens will not be available.	
	Active Shutdowns	Use this screen to view active Shutdown faults.
	Active Warning	Use this screen to view active Warning faults.
	History	Use this screen to view faults that have been cleared.
Genset Data	Use this screen to view the status of the generator set.	
Alternator Data	Use this screen to view the status of the alternator.	
Engine Data	Use this screen to view the status of the engine.	
Advanced Status:	---	
	Genset	Use this screen to view power, energy, phase difference, and other detailed generator set information.
	Controller	Use this screen to view sequences of operation, configurable inputs and outputs, and other detailed controller information.
	Engine	Use this screen to view pressures, voltages, temperatures, and other detailed engine information.
Help	Use this screen to obtain more information regarding the operator panel.	

Name	Description
Adjust	The use of these screens is restricted to authorized personnel only.
Genset Setup	
Paralleling Basic Setup	
OEM Setup	
PCCnet Setup	
Modbus Setup	
Display Options	
Clock Setup	
Configurable IO	
Calibration	
Save/Restore	

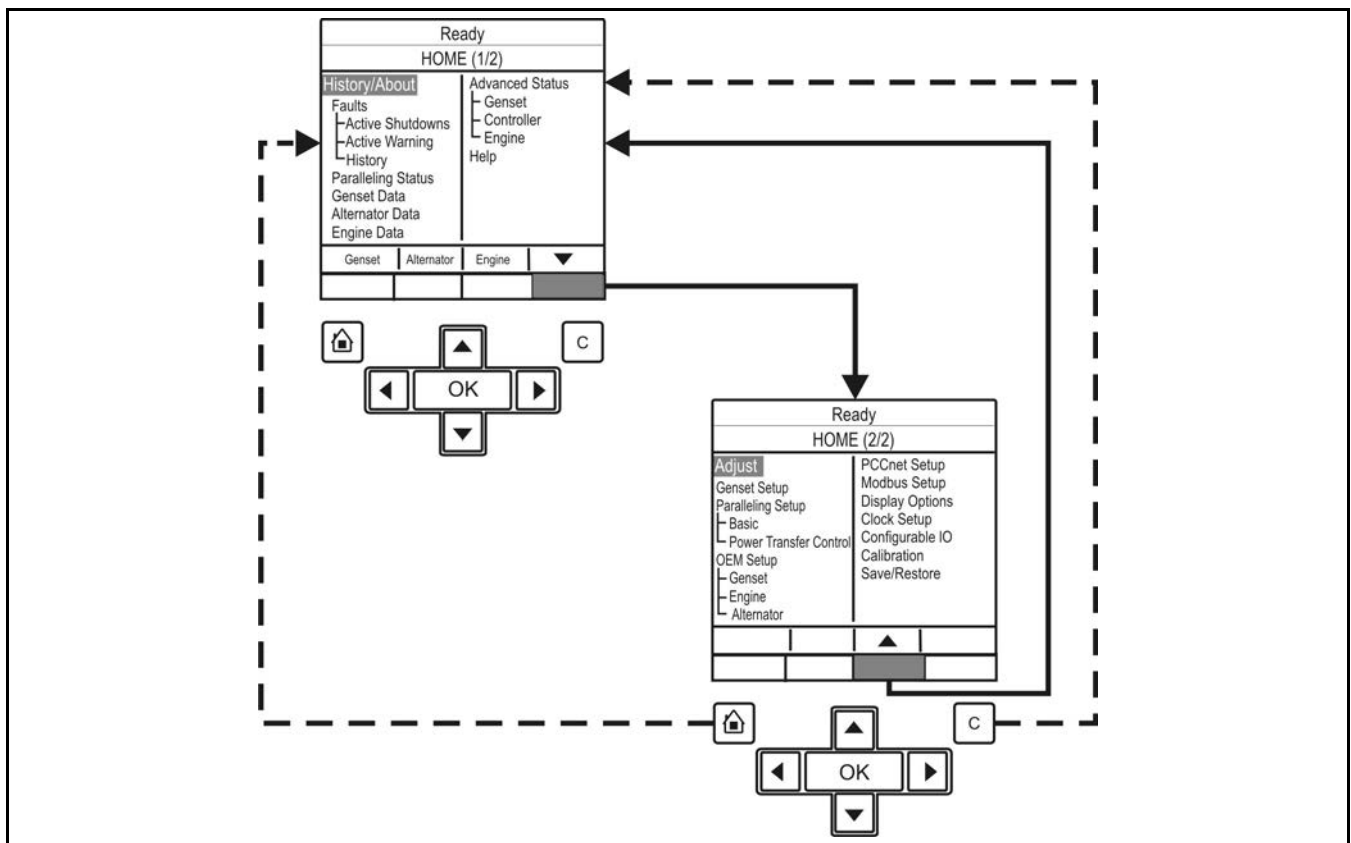



FIGURE 20. INITIAL OPERATOR MENU

- Press the **Home** Button  to return to the main menu at any time.

- Press the **C** Button  to return to the previous menus. Settings will not be saved when this button is pressed.

4.5 Operator Panel - Generator Set Data Operator Menu

The Genset Setup Data Menu - Typical Data table below shows a block representation of a typical Genset Data menu. To navigate from the Home menu (HOME [1/2]), press the soft-key button below the function button indicating Genset. This will take you directly to the Genset menu.

The Genset Data menu is displayed on two pages. Use the two soft-key buttons below the up and down arrows (▲ and ▼) to toggle between the pages.

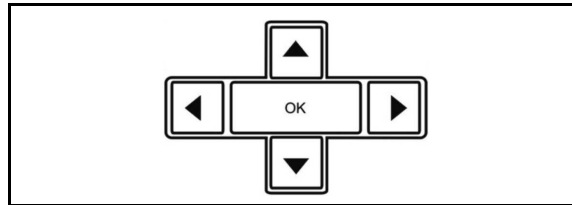

FIGURE 21. SELECTION BUTTONS

4.5.1 Generator Set Data

Use this menu to look at the status of the generator set.

TABLE 9. GENERATOR SET STATUS

Name	Description	Allowed Values
Alternator		
Avg Voltage	Generator set Line-to-Line average voltage	---
Avg Current	Generator set average current	---
Total kW	Generator set total kW	---
Total PF	Generator set power factor	---
Frequency	Generator set frequency	---
Engine		
Engine Hrs	Total engine run time	---
Coolant Temp	Monitor point for Coolant Temperature	---
Oil Pressure	Monitor point for Oil Pressure	0 to ~993 kPa (0 to ~145 PSI)
Batt Voltage	Battery voltage value	---
% Torq/Duty	Monitor point for the percent engine torque output and the governor percent duty cycle output when used with the HM ECM	-125 - ~125%
Fuel Rate	Monitor point for Fuel Rate	0 - ~845 L/hr (0 - ~223.2 gal/hr)

Name	Description	Allowed Values
Fuel Cons.	Fuel consumption since last reset	---
Total Fuel C.	Total fuel consumption since start of engine	---
Generator Set Application Rating		
kW rating	The generator set kW rating	---
kVA Rating	The generator set kVA Rating	---
Rated Current	The value of the generator set application nominal current	---
Generator Set Standby Rating		
kW rating	kW rating for the generator set in Standby configuration	---
kVA Rating	kVA rating for the generator set in Standby configuration	---
Rated Current	The value of the generator set Standby nominal current	---

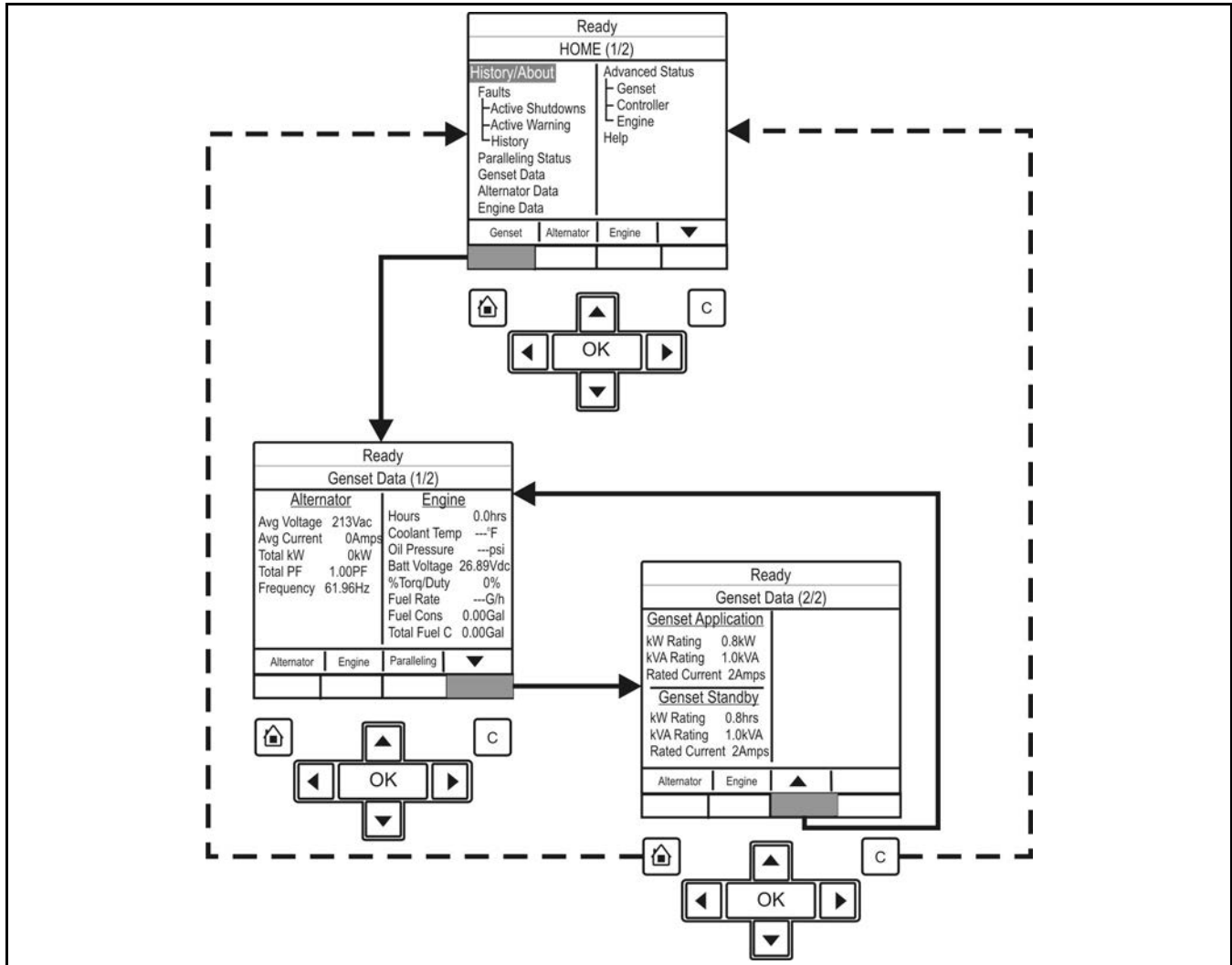



FIGURE 22. GENSET DATA MENU - TYPICAL DATA

- Press the **Home** Button  to return to the main menu at any time.
- Press the **C** Button  to return to the previous menus. Settings will not be saved when this button is pressed.

4.6 Operator Panel - Engine Data Operator Menu

The Engine Data Menu - Typical Data figure shows a block representation of a typical Engine Data menu. To navigate from the Home menu (HOME [1/2]), press the soft-key button below the function button indicating Engine. This will take you directly to the Engine menu.

The Engine Data menu is displayed on one page.

4.6.1 Engine Data Menu

Use this menu to look at the status of the engine.

TABLE 10. ENGINE DATA MENU

Name	Description	Allowed Values
Pressure		
Oil	Monitor point for Oil Pressure	0 - ~993 kPa (0 - ~145 psi)
Boost	Monitor point for Boost Absolute Pressure	0 - ~1014 kPa (0 - ~148 psi)
Fuel Rail	Monitor point for Fuel Outlet Pressure	0 - ~249364 kPa (0 - ~36404 psi)
Fuel Inlet	Monitor point for Fuel Supply Pressure	0 - ~993 kPa (0 - ~145 psi)
Coolant	Monitor point for Coolant Pressure	0 - ~993 kPa (0 - ~145 psi)
Crankcase	Monitor point for Crankcase Pressure	-244 - ~260 kPa (-35.67 - ~38 psi)
Ambient	Monitor point for Barometric Absolute Pressure	0 - ~253 kPa (0 - ~37 psi)
Temperature		
Coolant	Monitor point for Coolant Temperature	N/A
Oil	Monitor point for Oil Temperature	-40 - ~210 °C (-40 - ~410 °F)
Manifold	Monitor point for Intake Manifold Temperature—	-40 - ~210 °C (-40 - ~410 °F)
Fuel Inlet	Monitor point for Fuel Temperature	-40 - ~210 °C (-40 - ~410 °F)
Aftercooler	Monitor point for Aftercooler Temperature	-40 - ~210 °C (-40 - ~410 °F)
Other		
Engine Hrs	Total engine run time	
Engine Speed	Monitor point for Average Engine Speed	
Batt Voltage	Battery voltage value	

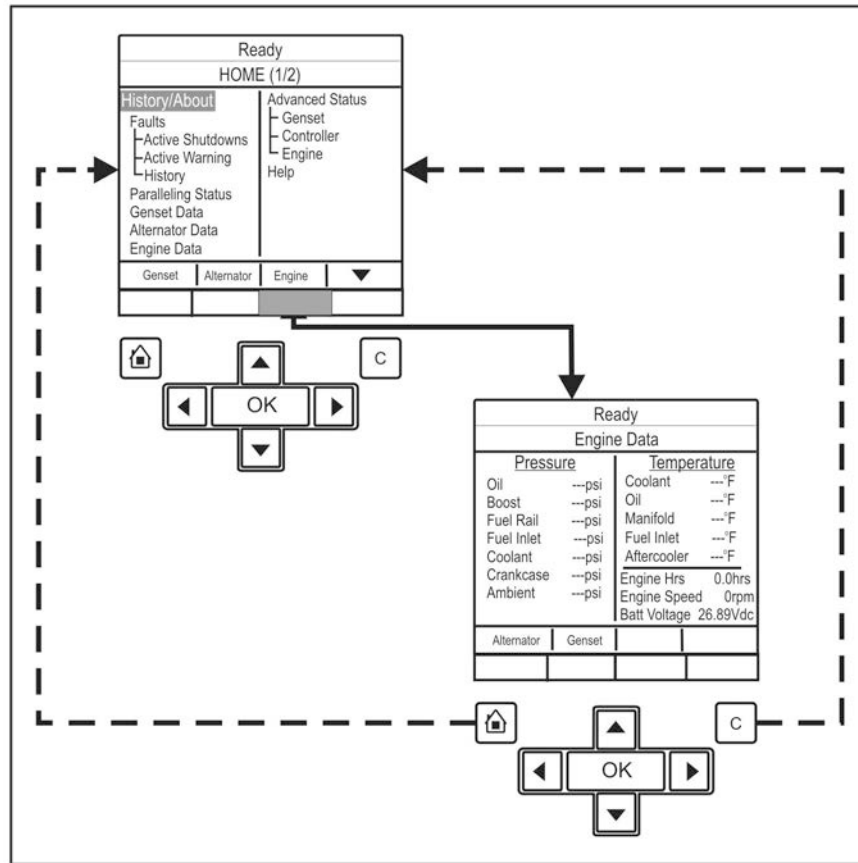



FIGURE 23. ENGINE DATA MENU - TYPICAL DATA

- Press the **Home** Button  to return to the main menu at any time.
- Press the **C** Button  to return to the previous menus. Settings will not be saved when this button is pressed.

4.6.2 History/About Menu

[Figure 24 on page 54](#) shows a block representation of a typical History/About menu.

To navigate from the Home menu, toggle down until the History/About line of text is highlighted, and press the OK button. This information is displayed over three pages. Use the two soft-key buttons below the up and down arrows (▲ and ▼) to toggle between the pages.

This screen displays the historical information about the generator set.

TABLE 11. HISTORY/ABOUT MENU

Name	Description
Starts	Total number of start attempts.
Runs	Total number of generator set runs.
Engine Hours	Total engine run time.
Control Hours	Controller ON time in seconds. Upper limit is 136 years.
Kw Hours	Generator set total net kWh accumulation.

Name	Description
Gen Mod #	Number identifying the model of the generator set. (Password level: 2)
Gen Ser #	Serial number identifying the generator set.
Nominal Voltage	Generator set nominal Line-to-Line voltage.
Wye/Delta	Delta or Wye for Generator set connection.
Rating Select	Selects Standby/Prime/Base application rating.
Contr Type	Used by the PC tool.
Firmware Ver	Version of software loaded into the control. Obtained from PowerCommand® 2.3 Filename.
Calib Part	The unique calibration part number loaded into the control.
Calib Date	The revision date of the calibration part number loaded into the control.
ECM Code	The calibration coded the ECM is sending.
HMI Firm Ver	Parameter: HMI Local Parameter.
HMI Boot Ver	Parameter: HMI Local Parameter.
50 Hz Load Profile*	This shows how long the generator set has been running (50 Hz operation) at various percentages of its rated load.
60 Hz Load Profile*	This shows how long the generator set has been running (60 Hz operation) at various percentages of its rated load.
* When using the Load Profile Graph table (for 50 Hz or 60 Hz), the upper line's value indicates 100% of table.	

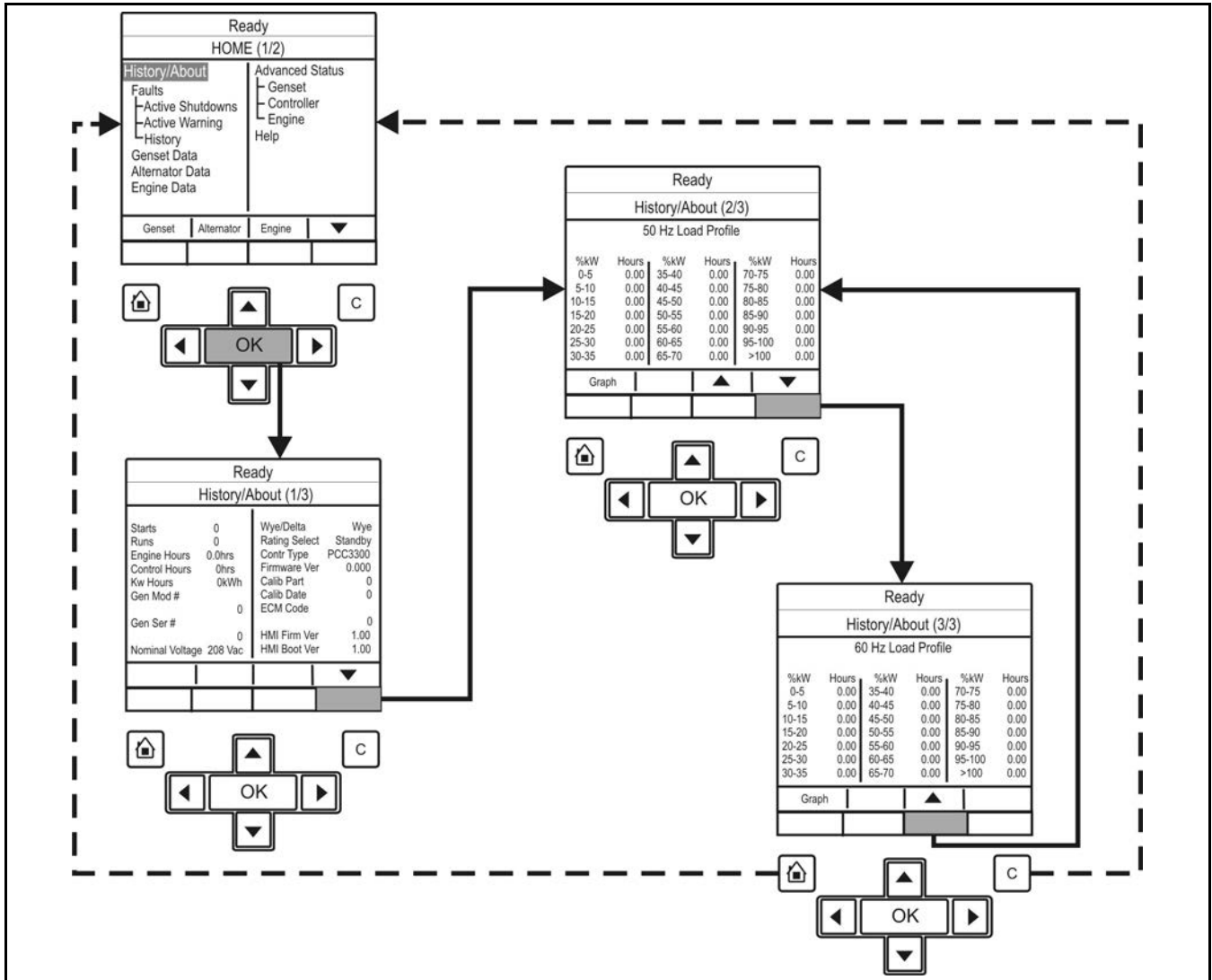



FIGURE 24. HISTORY/ABOUT MENU - TYPICAL DATA

- Press the **Home** Button  to return to the main menu at any time.
- Press the **C** Button  to return to the previous menus. Settings will not be saved when this button is pressed.

4.7 Operator Panel - Alternator Data Operator Menu

Figure 25 on page 56 shows a block representation of a typical Alternator Data menu. To navigate from the Home menu (HOME [1/2]), press the soft-key button below the function button indicating Alternator. This will take you directly to the Alternator menu.

The Alternator Data menu is displayed on one page.

4.7.1 Alternator Data

Use this menu to look at the status of the alternator. This menu displays line-to-line voltage, line-to-neutral voltage, current, and generator set power (in kVA). Some values are not available, dependent on the number of phases (one or three) and whether or not the application has current transformers.

TABLE 12. ALTERNATOR STATUS

Name	Description
L1 L2 L3	Alternator terminals
LL (VAC)	Generator set voltage: L1L2, L2L3, L3L1
LN (VAC)	Generator set voltage: L1N, L2N, L3N
Amps	Monitors the current generator set value: L1, L2, L3
kW	Generator set kW: L1, L2, L3
kVA	Generator set kVa: L1, L2 L3
PF*	Generator set power factor: L1, L2, L3
Total kW	Generator set total kW
Total kVA	Generator set total kVA
Total PF*	Generator set power factor
Frequency	Generator set frequency
AVR Duty Cycle	The AVR PWM software command; linear relationship between counts and % duty cycle with 10000 counts = 100% duty cycle
* A negative (-) value indicates a leading power factor; a positive (+) value indicates a lagging power factor.	

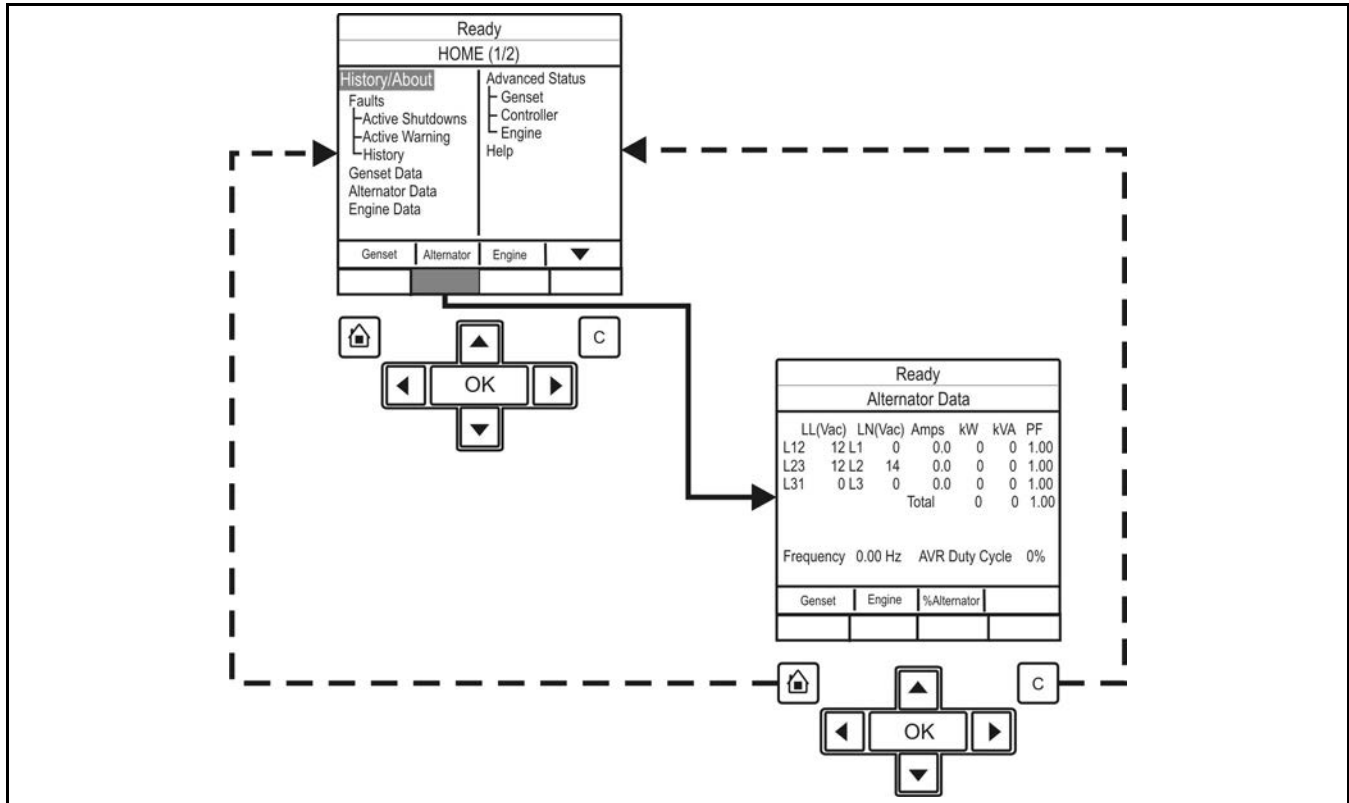



FIGURE 25. ALTERNATOR DATA MENU - TYPICAL DATA

- Press the **Home** Button  to return to the main menu at any time.
- Press the **C** Button  to return to the previous menus. Settings will not be saved when this button is pressed.



4.8 Operator Panel - Faults and Warnings Menus

The Faults and Warning menu is divided into three main sub-sections; Shutdown Faults (Active Shutdowns); Warning Faults (Active Warnings); and Faults History (showing up to thirty-two faults that have been cleared).

4.8.1 Shutdown Fault Menu

[Figure 26 on page 57](#) shows a block representation of a typical Shutdown Fault menu.

To navigate from the Home menu, toggle down until the Faults-Active Shutdowns line of text is highlighted, and press the **OK** button.

This will display information regarding the Shutdown fault(s). Use the two soft-key buttons below the up and down arrows ( and ) to toggle between the pages.

This screen displays up to five faults. The same event/fault code may appear multiple times if detected by different sources.

TABLE 13. SHUTDOWN FAULTS

Name	Description
Index	The index number of the fault
Fault	The Fault code
SA	The controller that identified the fault. It is blank if the PowerCommand® 2.3 control identified the fault
Eng Hrs	This is how many hours the engine had run (not necessarily continuously) when the fault was generated
HH/MM/SS	The time the fault was generated
Response	The type of fault that was generated

Note: The name of the fault appears below the rest of the information

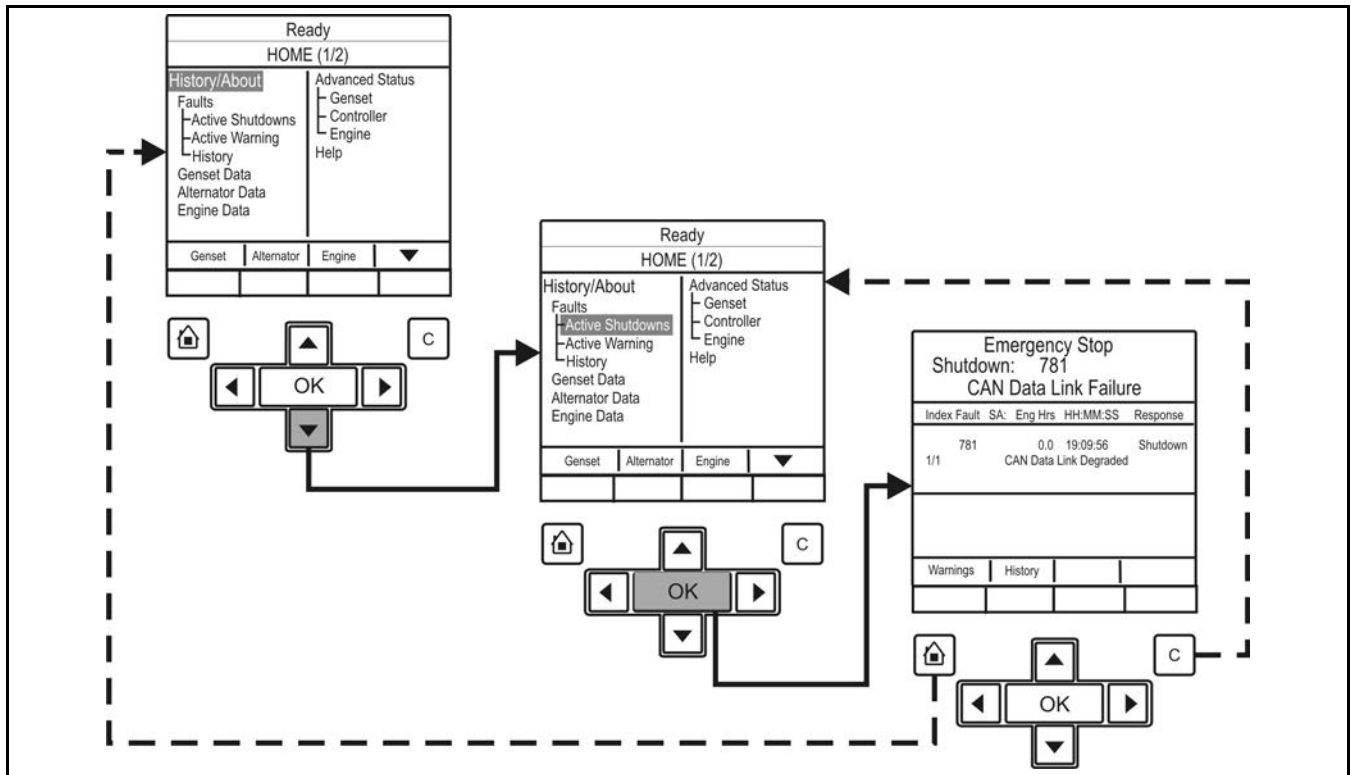



FIGURE 26. SHUTDOWN FAULTS MENU - TYPICAL DATA

- Press the **Home** Button  to return to the main menu at any time.
- Press the **C** Button  to return to the previous menus. Settings will not be saved when this button is pressed.

4.8.2 Fault Messages

A Fault message is an indicator of a Warning or Shutdown condition. It includes the fault type (Warning or Shutdown), fault number, and a short description. It also includes where the fault occurred if the generator set control did not detect the fault and is simply reporting the fault.

Active and acknowledged faults may be viewed in the Faults menu.

4.8.3 Fault Acknowledgement

Shutdown faults must be acknowledged after the fault has been corrected. If in Auto or Manual mode, the control must be set to Stop mode (Off). Faults are cleared from the control panel display by pressing the **Reset** button.

Faults are also acknowledged when in Auto mode and the remote start command is removed.

Faults are re-announced if they are detected again after being acknowledged.

4.8.4 Warning Fault Menu

[Figure 27 on page 59](#) shows a block representation of a typical Warning Fault menu.

To navigate from the Home menu, toggle down until the Faults - Warning Fault line of text is highlighted and press the **OK** button. This will then display information regarding the current fault. Use the two soft-key buttons below the up and down arrows (▲ and ▼) to toggle between the pages.

This menu displays up to thirty-two faults. The same event/fault code may appear multiple times if detected by different sources.

TABLE 14. WARNING FAULTS

Name	Description
Index	The index number of the fault
Fault	The Fault code
SA	The controller that identified the fault. It is blank if the PowerCommand® 2.3 control identified the fault
Eng Hrs	This is how many hours the engine had run (not necessarily continuously) when the fault was generated
HH/MM/SS	The time the fault was generated
Response	The type of fault that was generated
Note: The name of the fault appears below the rest of the information	

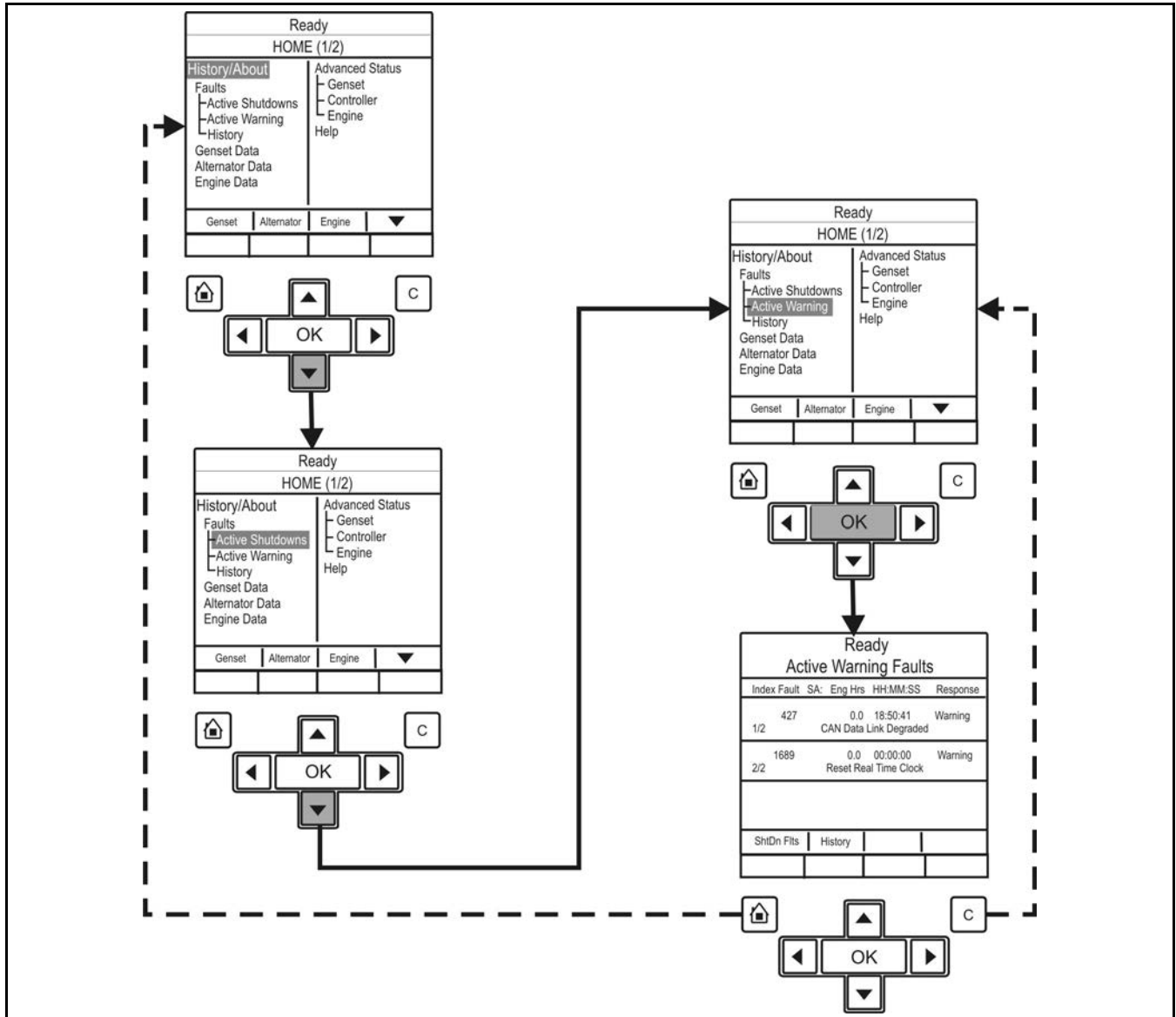

FIGURE 27. WARNING FAULT MENU - TYPICAL DATA

- Press the **Home** Button to return to the main menu at any time.
- Press the **C** Button to return to the previous menus. Settings will not be saved when this button is pressed.

4.8.5 Faults History Data Operator Menu

[Figure 28 on page 61](#) shows a block representation of a typical Fault History menu.

To navigate from the Home menu, toggle down until the Faults-History line of text is highlighted and press the **OK** button. This will then display information regarding the fault(s) history. Use the two soft-key buttons below the up and down arrows (**▲** and **▼**) to toggle between the pages.

This menu displays up to thirty-two faults. The same event/fault code may appear multiple times if detected by different sources.

TABLE 15. FAULTS HISTORY DATA

Name	Description
Index	The index number of the fault
Fault	The Fault code
SA	The controller that identified the fault. It is blank if the PowerCommand® 2.3 identified the fault
Engine Hrs	How many hours the engine had run (not necessarily continuously) when the fault was generated
DD/MM/YY	The date the fault was generated
HH/MM/SS	The time the fault was generated
Note: The name of the fault appears below the rest of the information.	

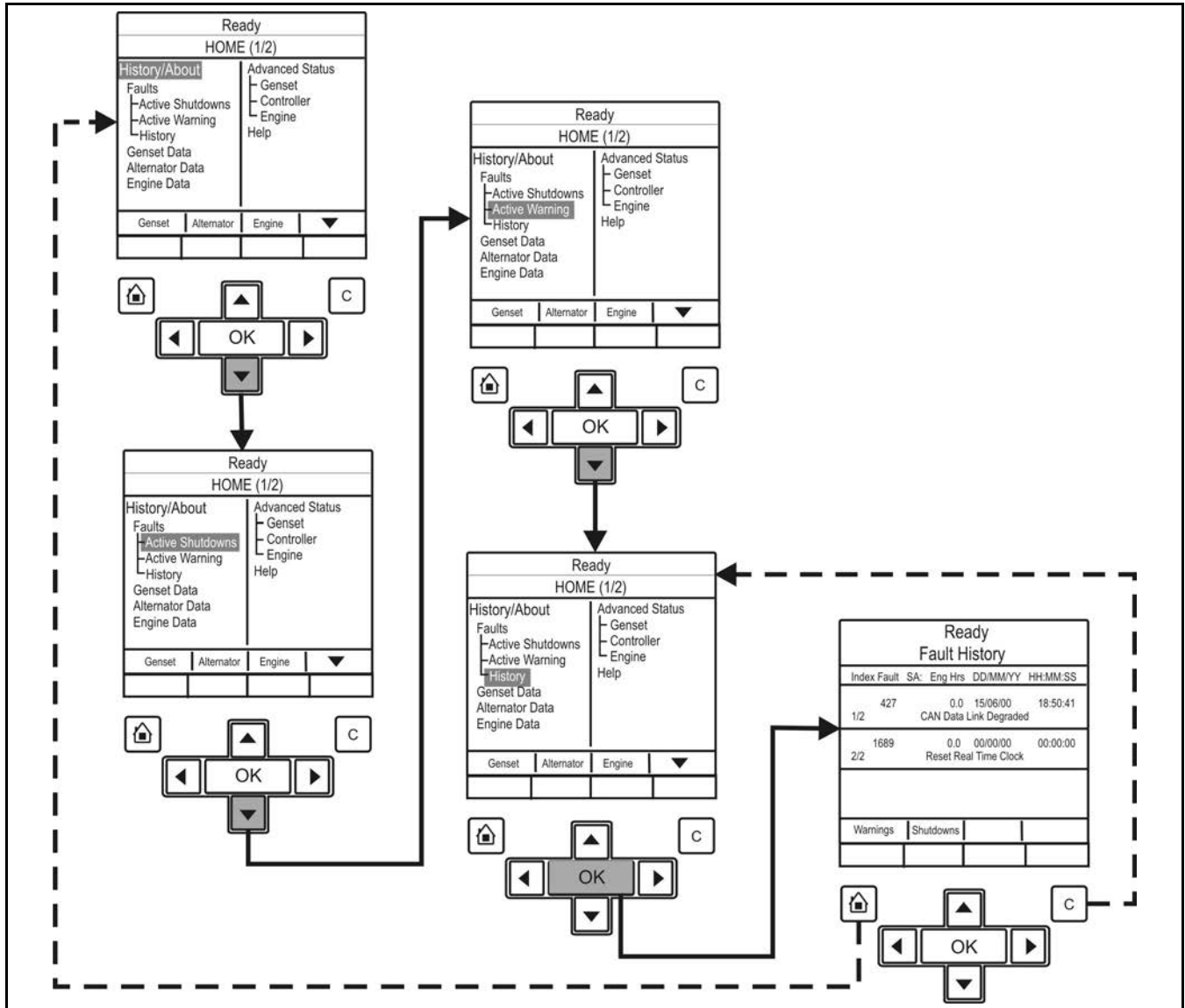



FIGURE 28. HISTORY FAULT MENU - TYPICAL DATA

- Press the **Home** Button  to return to the main menu at any time.
- Press the **C** Button  to return to the previous menus. Settings will not be saved when this button is pressed.

4.9 Operator Panel - Adjust Menu

[Figure 29 on page 63](#) shows a block representation of a typical Adjust menu. To navigate from the Home menu (HOME [1/2]), press the soft-key button below the down arrow in the display window. This will show the second page of the Home menu (HOME [2/2]). With the Adjust line of text highlighted, press the **OK** button to display the information.

The Adjust menu is displayed on one page.

NOTICE

If any of these settings require a change, please contact your authorized service center.

NOTICE

You cannot adjust Frequency Adjust or Voltage Adjust if Paralleling Speed Control Mode is set to Synchronize, Load Share, or Load Govern.

TABLE 16. ADJUST MENU

Name	Description	Allowed Values	Default Value
Voltage Adjust			
Genset LL Average Voltage	Generator set Line-to-Line average voltage	N/A	N/A
Voltage Adjust	A trim that allows the user to add/subtract an offset to the nominal voltage when calculating the voltage setpoint	-5 - ~5%	0%
Rated/Idle Sw	---	Rated, Idle	Rated
Exer Switch	---	Inactive, Active	Inactive
Man Warm Byp	---	Normal, Bypass Warmup	N/A
Keyswitch			
Keyswitch Status	---	Inactive, Active	N/A
Frequency Adjust			
Final Frequency Reference	The frequency scaled version of the final speed reference	0 - ~100 Hz	N/A
Frequency Adjust	A method of adding in a frequency offset to the base frequency subject to high and low limit calibrations.	-6 - ~6 Hz	0 Hz
Avr Gain	A trim that allows the user to modify the overall gains of the AVR.	0.05 - ~10	1
Governor Gain	A trim that allows the user to modify the overall gain of the governor.	0.05 - ~10	1
Start Delay	---	0 - ~300 seconds	0 seconds
Stop Delay	---	0 - ~600 seconds	0 seconds

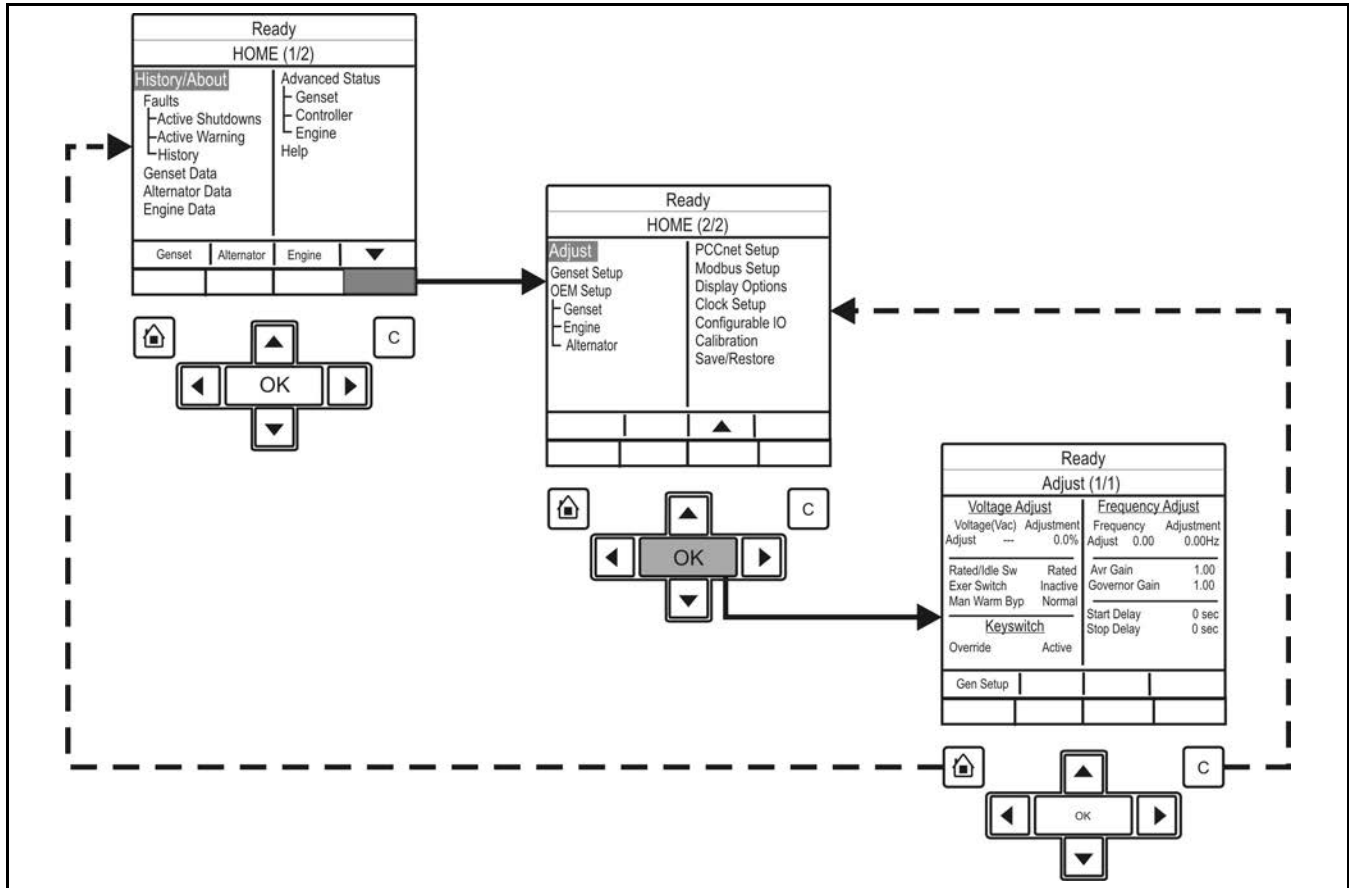







FIGURE 29. ADJUST MENU - TYPICAL DATA

- Press the **Home** Button  to return to the main menu at any time.
- Press the **C** Button  to return to the previous menus. Settings will not be saved when this button is pressed.

4.10 Operator Panel - Genset Setup Data Operator Menu

The figure below shows block representations of the Genset Setup Data menu.

1. Page down to the second page of the Home menu (using the two soft-key buttons below the up and down arrows [ and ]). See the Operator Panel - Initial Operator Menu section.
2. In the HOME (2/2) menu, using the up and down arrows, toggle down again until the Genset Setup text is highlighted.
3. With the Genset Setup line of text highlighted, press the **OK** button. This will display the Setup Menu.
4. Use the two soft-key buttons below the up and down arrows [ and ]) to page through the five pages of the generator Setup data.

NOTICE

if any of these settings need to be changed, please contact your authorized service center.

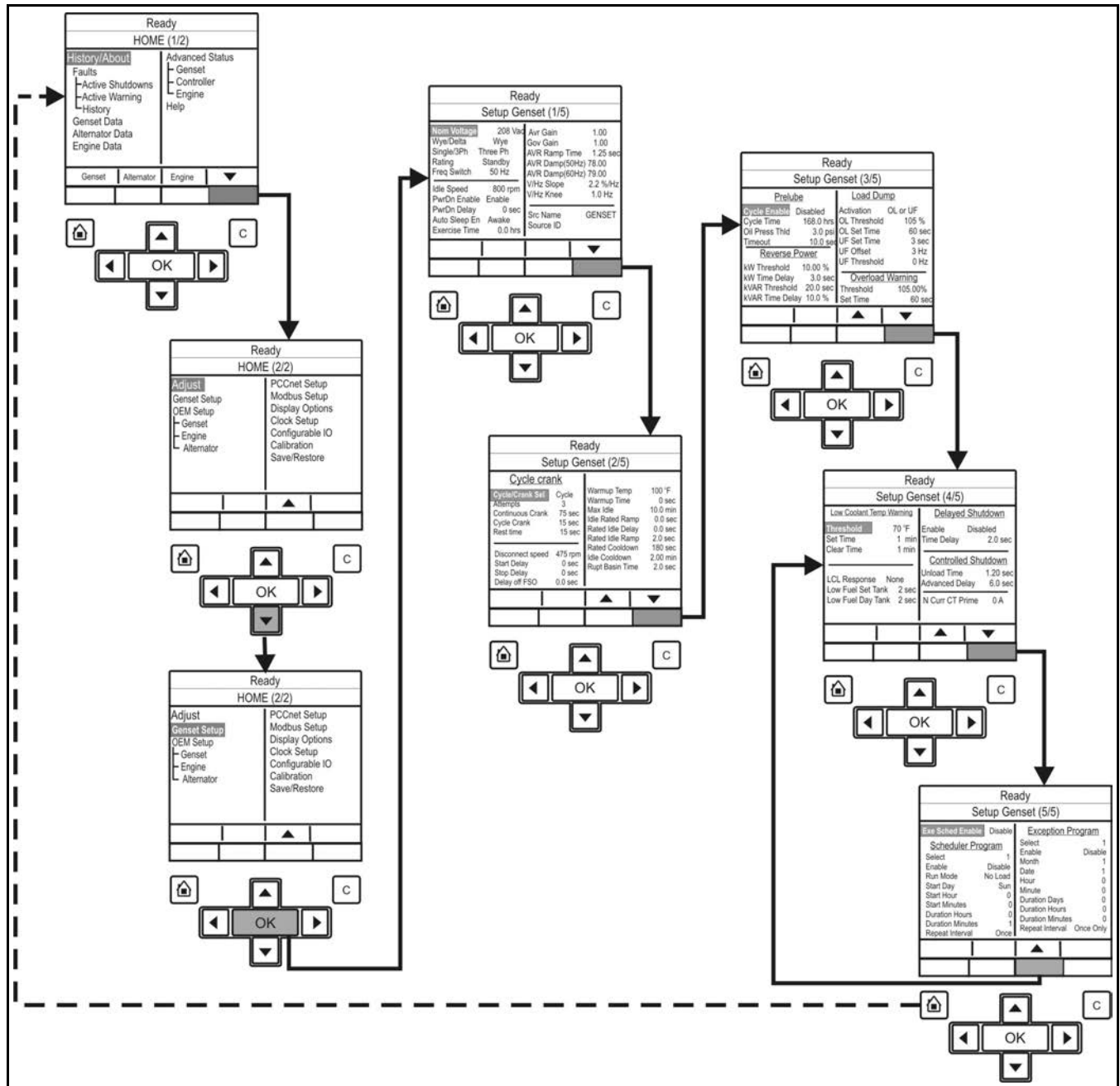



FIGURE 30. GENSET SETUP DATA MENU - TYPICAL DATA

- Press the **Home** Button  to return to the main menu at any time.
- Press the **C** Button  to return to the previous menus. Settings will not be saved when this button is pressed.

4.11 Selecting Operating Modes

4.11.1 Passwords and Mode Change Access

4.11.1.1 Entering the Mode Change Access Code

The Mode Change submenus are intended for qualified service personnel and site personnel only, and by default will require an Access password. If a password is required, the Mode Change – Access Code menu will appear when you try to switch between Auto, Manual Run, or Stop modes.

To enter the mode access code:

1. With the first character highlighted, press the up and down arrow buttons until the required value is displayed.
2. Press the left arrow button to move to the next numeric character.
3. Repeat steps 1 and 2 until all characters of the Access Code are correct.
4. After you have completed entering the password, press the **OK** button.

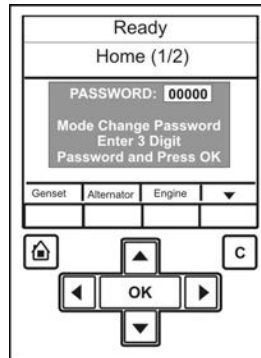

FIGURE 31. MODE CHANGE ACCESS CODE DISPLAY SCREEN

NOTICE

If an incorrect password is entered, the Operator menu that was displayed before Auto, Manual Run, or Stop mode was selected is re-displayed.

4.11.1.1.1 Passwords

It is possible for the operator to view every parameter in the graphical display; however, a password may be required before adjustment of a parameter is permitted. The generator set will prompt you if a password is required and inform you of the level of password required.

TABLE 17. PASSWORDS



Level	Description	Comment
0	No password	None required
1	Operator password	Restricted
2	Service password	Restricted
3	Engineering password	Restricted

4.11.2 Selecting Manual Run Mode

NOTICE

When changing modes, the generator set may start or stop without warning. Make sure there is no danger to personnel or equipment should the generator set unexpectedly start or stop.



Press the **Manual** button  and then (within ten seconds) the **Start** button . This bypasses the "Time Delay to Start" function and activates the engine control system and the starting system.

If the engine does not start, the starter disengages after a specified period of time and the controller indicates a "Fail to Start" shutdown.

The generator set can be configured for 1–7 starting cycles with set times for crank and rest periods for all starting modes (manual/remote). The default setting is 3 start cycles, composed of 15 seconds of cranking and 30 seconds of rest.

NOTICE

The InPower service tool or access to the setup menu is required to change the cycle number, and crank and rest times. Contact your authorized distributor for assistance.



To clear a Fail to Start shutdown, press the **Stop** button  and then press the **Reset** button .

Before attempting to restart, wait 2 minutes for the starter motor to cool and repeat the starting procedure. If the engine does not run after a second attempt, refer to the Troubleshooting section.

4.11.3 Selecting Auto Mode

NOTICE

When changing modes, the generator set can start or stop without warning. Make sure there is no danger to personnel or equipment should the generator set start or stop.

NOTICE

Make sure that it is safe to do so before proceeding to change the mode.



Press the **Auto** button.  This allows the generator set to be started from a remote switch or device (e.g. transfer switch).

In response to the **Remote Start**, the control lights the Remote Start indicator and initiates the starting sequence. This start incorporates a Time Delay to Start function.

NOTICE

The InPower service tool or access to the setup menu is required to change the cycle number, and crank and rest times. Contact your authorized distributor for assistance.

NOTICE

Should a remote start signal be received, the generator set starts automatically. Make sure there is no danger to personnel or equipment should the generator set start without warning.

The starting/stopping sequence for a remote start is as follows:

1. A **remote start** signal is received at the customer connection on the generator set. This input signal is received from a transfer switch, a remote start switch, etc.
2. The Time Delay to Start (0–300 seconds) begins.
3. When the Time Delay to Start has expired, the engine starts. Once it has reached its rated speed and voltage, the generator set is available for use.
4. When the **remote start** signal is removed, a Time Delay to Stop (0–600 seconds) begins. This time delay is used to transfer the load (if connected to another power source) and let the engine cool down.
5. When the Time Delay to Stop has expired, the engine stops.

NOTICE

If the emergency stop or control off button is pressed at any time during the starting/stopping sequence, the engine immediately stops, bypassing the cooldown sequence.

4.11.4 Selecting Off Mode

NOTICE

When changing modes, the generator set can stop without warning. Make sure there is no danger to personnel or equipment should the generator set stop.



Press the **Stop** button  to put the generator set into the Off mode. This disables Auto and Manual modes.

If the generator set is running in either Manual or Auto mode, and the **Stop** button is pressed, the engine will shut down. This action may include a cool down run.

NOTICE

Do not perform a hot shutdown under load; a hot shutdown may result in engine damage.

This page is intentionally blank.

5 Operation - PowerCommand 2.3

5.1 Safety

WARNING

Toxic Gases

Inhalation of exhaust gases can cause asphyxiation and death.

Use extreme care during installation to provide a tight exhaust system. Terminate exhaust pipes away from enclosed or sheltered areas, windows, doors, and vents. Do not use exhaust heat to warm a room, compartment, or storage area.

WARNING

Hazardous Voltage

Contact with high voltages can cause severe electrical shock, burns, or death.

Do not open the generator set output box while the generator set is running. Read and observe all warnings and cautions in the generator set manuals.

CAUTION

Hazardous Voltage

Contact with high voltages can cause severe electrical shock, burns, or death.

Make sure that only suitably trained and experienced service personnel perform electrical and/or mechanical service. Even with the power removed, improper handling of components can cause electrostatic discharge.

Only trained and experienced personnel should carry out generator set operations. Before operating the system, the operator should become familiar with all health and safety procedures, warnings, cautions, precautions, and the other documentation supplied with the generator set. (See [Chapter 1 on page 1](#)). Observe all of the warnings and cautions at all times.

NOTICE

Before operating the generator set become familiar with the equipment and how it is operated (including all controls, manually operated valves, and alarm devices). Safe and efficient operation can only be achieved if the generator set is operated correctly.

5.2 Introduction

This section describes the operation of the generator set. The text should be read in conjunction with the System Overview and the Control System Sections of this manual.

All indicators, control switches/buttons, and graphical display are located on the face of the Operator Panel.

5.3 Maintenance

To ensure maximum performance and reliability from your generator set, it is essential that certain components are inspected periodically and, where necessary, maintenance procedures are carried out, as detailed in the Maintenance chapter.

5.4 Operating Recommendations

5.4.1 Running-in

Refer to the Maintenance chapter of this manual. Special "running-in" oils are not recommended for new or rebuilt Cummins engines. Use the same type of oil during "running-in" as is used in normal operation.

The engine should be run at varying loads during the first few hours of operation to allow the components to "bed in." Avoid long periods of light load or full load running particularly during the early life of the engine.

5.4.2 No Load Operation

Periods of no load operation should be held to no longer than 15 minutes. Long periods of no load operation can result in engine and (if fitted) diesel particulate filter damage.

If it is necessary to keep the engine running for long periods of time when no electric output is required, best engine performance will be obtained by connecting a load of at least 30% rated load, but not to exceed rated load. Such a load could consist of a heater element or load bank.

5.4.3 Exercise Period

Generator sets on continuous standby must be able to go from a cold start to being fully operational in a matter of seconds. This can impose a severe burden on engine parts.

Regular exercising keeps engine parts lubricated, prevents oxidation of electrical contacts, and in general helps provide reliable engine starting.

Exercise the set for a minimum of ten minutes off-load at least once a week and for a minimum of 30 minutes with load at least once each month so that the engine reaches normal operating temperatures.

5.4.4 Low Operating Temperatures

NOTICE

Operating engines at idle (650 to 1000 rpm) in cold ambient temperatures wastes fuel, accelerates wear, and can result in serious engine damage. Under low temperature conditions, incomplete combustion will occur, allowing deposits of unburned tars and carbon to buildup on the valve guide and valves, and eventually cause valve sticking.

In cold climates it is critical that the following items be appropriately maintained and selected based on ambient operating temperatures. Check to be sure:

- The battery is properly sized.
- An appropriate mixture of antifreeze is used in the cooling system.
- The proper grade of fuel is being used.
- The correct weight of engine oil is being used.

Use a coolant heater if a separate source of power is available. The optional heater available from Cummins will help provide reliable starting under adverse weather conditions. Make sure the voltage of the separate power source is correct for the heater element rating.

5.4.5 High Operating Temperatures

In high ambient temperatures, when operating at full load, it is normal for the high temperature warning to be given. This indicates that the engine is operating near to its maximum capacity and is normal. If operation in high temperature environments is anticipated, increase the frequency of checks for coolant level, obstructions of cooling air inlets and outlets, and debris at the radiator.

Refer to the generator set nameplate for the maximum operating temperature, if applicable.

5.4.6 Operating Conditions

NOTICE

All generator sets supplied by Cummins must be run under the following operating conditions, and in accordance with the operating information contained within the literature package supplied with each generator set.

5.4.6.1 Prime Power Rating (PRP) for Variable Load Applications

The Prime Power Rating (PRP) is the maximum power available during a variable load sequence which may be run for an unlimited number of hours per year, between the stated maintenance intervals and under the stated ambient conditions. All maintenance must be carried out as prescribed in Cummins manuals. Prime power applications fall into one of the following two categories:

- Unlimited time prime power (for variable load applications)

Prime power is available for an unlimited number of annual operating hours in variable load applications. The permissible average power output under variable load shall not exceed a 70% average of the prime power rating during any operation of 250 hours. The total operating time at 100% prime power shall not exceed 500 hours per year. A 10% overload capability is available for a period of 1 hour within a 12-hour period of operation, in accordance with ISO 8528-1 2005. Total operating time at the 10% overload power shall not exceed 25 hours per year.

- Limited running time prime power (for constant load applications) (LTP)

Prime power is available for a limited number of hours in a non-variable load application. It is intended for use in situations where power outages are contracted, such as utility power curtailment. Generator sets may be operated in parallel with the public utility up to 750 hours per year at power levels never to exceed the prime power rating. No sustained overload capability is available at this rating. The customer should be aware, however, that the life of any generator set will be reduced by constant high load operation. Any operation exceeding 750 hours per year at the prime power rating should use the Continuous Power Rating.

5.4.6.2 Emergency Standby Power Rating (ESP) for Variable Load Applications

The Emergency Standby Power Rating (ESP) is applicable for supplying emergency power for the duration of a utility power interruption, between the stated maintenance intervals and under the stated ambient conditions. All maintenance must be carried out as prescribed in Cummins manuals. No overload capability is available for this rating and utility parallel operation is not permitted at the standby power rating. For applications requiring sustained utility parallel operation, the limited time prime power rating or continuous power rating must be utilized as applicable.

This rating is applicable to installations served by a reliable normal utility source. Generator sets should be sized for a maximum average load factor of 80% of the standby power rating with a maximum of 200 hours of operation per year, which includes less than 25 hours per year at the standby power rating. In installations served by unreliable utility sources (where outages last longer or occur more frequently), where operation is likely to exceed 200 hours per year, the prime power rating should be applied. The standby rating is only applicable for emergency and standby applications where the generator set serves as the back up to the normal utility source. Negotiated power outages are not considered as emergencies.

5.4.6.3 Applicable to All Ratings

The following information applies to all ratings, unless otherwise agreed by the Regional Sales Manager of Cummins in writing:

- When determining the actual average power output of a variable power sequence in any of the ratings above, powers of less than 30% of the emergency standby power are taken as 30% and time at no load shall not be counted.
- Variable load is calculated in accordance with methods and formulas given in ISO 8528-1-2005.
- All three-phase generators are rated for 0.8 power factor lag. Single-phase generators are rated for 1.0 power factor.
- All ratings are based on the following reference conditions:
 - Ambient temperature: 27 °C (81 °F)
 - Altitude above sea level: 150 m (490 ft)
 - Relative humidity: 60%
- If any of the above conditions are exceeded, the output may be subject to de-rate.
- If any of the above conditions are not satisfied, the operational life of the generating set may be reduced.
- Short term parallel operation with the utility for load transfer purposes only is permitted with all ratings.

5.4.7 De-Rating Factors

Engine power and resulting electrical output decrease as ambient temperature or altitude increases. For de-rating factors applicable at specific sites, contact your authorized distributor.

5.5 Generator Set Operation

WARNING

Combustible Vapors

Engine over speeding can cause component failure, fire, or an explosion; which can cause severe personal injury or death.

Do not operate an engine where there are or can be combustible vapors.

Correct care of the engine will result in longer life, better performance, and more economical operation.

Numerous safety devices may be available, such as air intake shutoff devices, to minimize the risk of overspeeding in which an engine, because of application, might operate in a combustible environment (from a fuel spill or gas leak, for example). Cummins does not know how the engine will be used. The equipment owner and operator, therefore, is responsible for safe operation in a hostile environment. Consult your authorized distributor for further information.

NOTICE

Cummins recommends the installation of an air intake shutoff device or a similar safety device to minimize the risk of overspeeding where an engine will be operated in a combustible environment.

NOTICE

Long periods of idling (more than ten minutes) can damage an engine. Do not idle the engine for excessively long periods.

5.5.1 Sequence of Operation

The generator set is run automatically using a **Remote Start** signal, or manually using the generator set control panel buttons. LEDs are provided on the operator panel to indicate the operating run mode of the generator set. The PowerCommand® control initiates a starter cranking signal and performs an automatically sequenced manual start, under a complete engine protection system combined with full monitoring capability. If a fault is sensed at start-up, the engine is locked out and will not start.

The choice of **Auto** or **Manual Run** mode is decided by authorized personnel during the generator set initial setup. An access code is required to switch between the **Auto**, **Manual Run**, or **Off** modes, and this facility may be permitted or denied by the authorized personnel during the initial setup of the generator set.

5.6 Before Starting

NOTICE

One operator should be in complete charge, or working under the direction of someone who is in charge. Remember that, upon starting the engine, cables and switchgear will become energized, possibly for the first time. Furthermore, equipment that does not form part of the generator set installation may become electrically charged. Only authorized and competent personnel should carry out this work.

NOTICE

Do not use the Emergency Stop button to shut down an engine unless a serious fault develops. The Emergency Stop button must not be used for a normal shut-down as this will prevent a cooling down run in which the lubricating oil and engine coolant carry the heat away from the engine combustion chamber and bearings in a safe manner.

NOTICE

Diesel engines only: Avoid off-load running for other than short periods. A minimum loading of 30% is recommended. The engine must be shut down as soon as possible after the appropriate functions have been checked.

NOTICE

Gaseous engines only: Avoid running the generator set at no-load and light-loads for extended periods.

Before attempting to start the generator set, the operator should read through this entire manual and the specific literature provided as part of the documentation pack supplied with the generator set. It is essential that the operator be completely familiar with the generator set and the PowerCommand® control.

The sub-sections below cover the systems used to start and stop the generator set.

Before starting the generator set, make sure that exhaust and fuel fittings are tight and properly positioned, and that proper maintenance and pre-start checks have been performed.

During starting, automatic checks are carried out for the integrity of various protection systems. The PowerCommand® control will not allow the generator set to continue the starting sequence if the integrity of a sensor is considered to be in doubt.

The generator set can be configured for a number of starting cycles (one to seven) with set times for crank and rest periods for all starting modes (manual/remote). The default setting is for three start cycles, composed of fifteen seconds of cranking and 30 seconds of rest.

NOTICE

The number of starting cycles, and the crank and rest times are set from within the Setup menu. Trained and experienced service personnel are required to change the default setting. Contact your authorized Cummins distributor.

5.6.1 Operator's Pre-Start Checks

⚠ WARNING

Arc Flash and Shock Hazard

***Electric arc flash can cause electrical shock, severe burns, or death.
Make sure the alternator is dry before the generator set is operated.***

⚠ WARNING

Hot Pressurized Liquid

***Contact with hot liquid can cause severe burns.
Do not open the pressure cap while the engine is running. Let the engine cool down before removing the cap. Turn the cap slowly and do not open it fully until the pressure has been relieved.***

NOTICE

Radiators with two fill necks only: Both fill necks must be filled when the cooling system has been drained.

TABLE 18. OPERATOR'S PRE-START CHECKS

Check	Description
Fuel Supply (<i>Diesel Only</i>)	<p>Make sure that:</p> <ul style="list-style-type: none"> The fuel tank is filled to the normal level with clean water-free fuel and that the fuel system is primed; All the valves required for operation are open; There are no leaks and that all fittings are tight; and If equipped, the auxiliary fuel system is properly connected.
DEF Supply (<i>If Equipped</i>)	<p>Make sure that:</p> <ul style="list-style-type: none"> The DEF tank is filled to the normal full level with DEF, and If equipped, the auxiliary DEF system is properly connected.
Lubrication	With the engine stationary, check the engine lubrication oil level and make sure that the correct level is always maintained.
Coolant	Check the engine coolant level and make sure that the level is always maintained at the coolant expansion tank. Fill the cooling system to the bottom of the fill neck in the radiator fill or expansion tank. Do not check while the engine is hot.
Cooling Air Inlet/Outlets	Make sure that the cooling air inlets/outlets are unobstructed.
Exhaust Outlet	<p>Make sure that:</p> <ul style="list-style-type: none"> Exhaust components are secured and not warped; The exhaust outlet is unobstructed; No combustible materials are near the system; Gases are discharged away from building openings; and There are no leaks and that all fittings are tight.
Batteries	Make sure that the batteries are charged, and that all connections are clean, correct and tight (if applicable).
Auxiliary Powered AC Supplies	Make sure that all auxiliary equipment is receiving power from the customer's supply.
Emergency Stop	Make sure that the emergency stop button is fully operational.

5.6.2 Starting at the Operator Panel (Manual Run Mode)

NOTICE

Make sure that all Pre-start Checks are carried out before starting the generator set. Do not attempt to start the generator set until it is safe to do so. Warn all others in the vicinity of the generator set and connected load equipment that the generator set is about to start.

STARTING IN MANUAL RUN MODE

1. Make sure the main circuit breaker is in the open position.

2. To start the generator set in the **Manual Run** mode:

- a. Press the **Manual** button  on the operator panel.

- b. Press the **Start** button  within ten seconds.

NOTICE

Failure to press the Start button within this time will result in the generator set changing to the Off mode. Refer also to the Selecting Manual Run Mode section.

NOTICE

If the mode change access code feature has been enabled, enter the access code when prompted. See the Passwords and Mode Change Access section.

3. The PowerCommand® control will initiate a starter cranking signal and will perform an automatically sequenced manual start, under a complete engine protection system combined with full monitoring capability. This will activate the engine control system and the starting procedure. The starter will begin cranking and, after a few seconds, the engine will start and the starter will disconnect.

If the engine fails to start, the starter will disengage after a specified period of time and the control will indicate a Fail to Start shutdown.

To clear a Fail to Start shutdown:

- a. Press the **Stop** button. 
- b. Press the **Reset** button. 

4. Before attempting to re-start, wait a minimum of two minutes for the starter motor to cool and then repeat the starting procedure. If the engine does not run after a second attempt, refer to the Troubleshooting section of the operator manual.

DISABLING MANUAL MODE

To disable Manual mode, change to **Auto** or **Off** mode. If the generator set is running when it leaves **Manual** mode, it will continue to run if **Auto** mode has been selected and the remote start signal is active. If there is no active remote start signal, the generator set will stop.

5.6.3 Starting from Remote Location (Auto Mode)

NOTICE

Make sure that all Pre-start Checks are carried out before starting the generator set. Do not attempt to start the generator set until it is safe to do so. Warn all others in the vicinity that the generator set is about to start.

1. To start the generator set in the **Auto Run** mode, select the **Auto** button from the operator panel.



Refer also to the Selecting Auto Mode section.

Once the PowerCommand® control receives a remote start signal, and after a Time Delay to Start, the control will initiate the starting sequence as above. The Remote Start LED will be lit.

NOTICE

If the mode change access code feature has been enabled, enter the access code when prompted. See the Passwords and Mode Change Access section.

NOTICE

When the generator set is operating in the Remote Start mode, removing the Remote Start command does not shut off the engine if the load is more than 10%, the cooldown timer is set to zero, and the control is configured for a single unit (not in parallel). The generator set continues to operate until it runs out of fuel, the E-stop button is used, or the load is removed.

- To disable **Auto** mode, change to **Manual** or **Off** mode.

5.6.4 Cold Starting with Loads

NOTICE

Make sure that all pre-start checks are carried out before starting the generator set. Do not attempt to start the generator set until it is safe to do so. Warn all others in the vicinity that the generator set is about to start.

Use a coolant heater if a separate source of power is available. The optional heater available from Cummins will help provide reliable starting under adverse weather conditions. Be sure the voltage of the separate power source is correct for the heater element rating.

Cummins recommends equipping standby generator sets (life safety systems) with engine water jacket coolant heaters to maintain the coolant at a minimum of 32 °C (90 °F) and, for most applications, accept the emergency load in ten seconds or less. Although most Cummins generator sets will start in temperatures down to -32 °C (-25 °F) when equipped with engine water jacket coolant heaters, it might take more than ten seconds to warm the engine up before a load can be applied when ambient temperatures are below 4 °C (40 °F).

The **Low Coolant Temp** (Code 1435) message along with the lighting of the **Warning** LED are provided to alert the operator of a possible delay in accepting the load. The engine cold sensing logic initiates a warning when the engine water jacket coolant temperature falls below 21 °C (70 °F). In applications where the ambient temperature falls below 4 °C (40 °F), a cold engine may be indicated even though the coolant heaters are connected and functioning correctly. Under these conditions, although the generator set may start, it may not be able to accept load within ten seconds. When this condition occurs, check the coolant heaters for correct operation. If the coolant heaters are operating correctly, other precautions may be necessary to warm the engine before applying a load.

5.6.4.1 Checking Coolant Heater Operation

⚠ WARNING**Hot Surfaces**

Contact with the hot surfaces can cause severe burns.

Avoid contact with hot parts. Allow hot parts to completely cool.

Do not touch the cooling system outlet hose. The coolant heater is operating if radiant heat can be felt with your hand held close to the outlet hose and the engine is not running.

5.7 Stopping

NOTICE

The access code may be required before initiating the Off button sequence. See the Passwords and Mode Change Access section.

NOTICE

Run the generator set at no load for three to five minutes before stopping. This allows the lubricating oil and engine coolant to carry heat away from the combustion chamber and bearings.

5.7.1 Stopping at the Operator Panel (Manual Mode)

NOTICE

If possible, hot shutdown under load should be avoided to help prolong the reliability of the set. A hot shutdown results in a Hot Shutdown Warning.

NOTICE

Hot shutdown under load should be avoided whenever possible to prolong the reliability of the set. A hot shutdown may result in a Hot Shutdown Warning.

NOTICE

Pressing the stop button twice stops the generator set immediately without a cool down run after which the set enters the off mode.

To shut down a generator set that was started in manual mode.

1. Remove the load.
2. Open the main circuit breaker.
3. Press the stop button on the HMI operator panel. This initiates the generator set cool down run. The HMI displays the cool down count down timer at this time. Once the cool down timer has expired, the generator set shuts off and enters off mode.

5.7.2 Stopping from the Operator Panel (Auto Mode)

If the generator set was started in **Auto** mode, press the **Stop** button  once to stop the generator set immediately.

NOTICE

If possible, hot shutdown under load should be avoided to help prolong the reliability of the generator set.

5.7.3 Stopping from a Remote Location (Auto Mode)

If the control receives a remote stop signal, the generator set completes its normal shutdown sequence incorporating a Cooldown run. See the Selecting Auto Mode section. (The remote stop signal is actually the removal of the remote start signal to the control.)

The generator set stops after completing the Time Delay to Stop function (zero to 600 seconds).

The set will remain in the **Auto** mode and subject to a remote start signal, unless the **Stop** button is pressed. If this button is pressed, the generator set will enter the **Off** mode.

NOTICE

The InPower service tool or access to the Setup menus is required to enable and change the time delay start/stop settings. Contact your authorized distributor for assistance.

5.7.4 Code 1433 or 1434 - Emergency Stop

The local **Emergency Stop** button is situated on the front of the operator panel. This is a mechanically latched switch that will unconditionally stop the engine when pressed, bypassing any time delay to stop. Push this button for emergency shutdown of the engine.

NOTICE

If the engine is not running, pushing the button will prevent the starting of the engine, regardless of the start signal source (Manual or Auto - Remote).

When the **Stop** button is pressed, the display will indicate the shutdown condition by illuminating the red **Shutdown** status LED  and displaying the following message on the graphical LCD display:

- Fault Number: 1433 LOCAL EMERGENCY STOP

A remote **Emergency Stop** button may be incorporated within the installation. If this remote **Emergency Stop** button is activated, the following message will be displayed:

- Fault Number: 1434 REMOTE EMERGENCY STOP

To reset:

1. Pull, or twist and pull the button out.
2. Press the **Stop** button on the operator panel to acknowledge this action.
3. Press the **Reset** button.
4. Press the **Auto** or **Manual Run** button, as previously determined. See the Selecting Operating Modes section.

NOTICE

Do not use an Emergency Stop button to shut down an engine unless a serious fault develops. The Emergency Stop button must not be used for a normal shut-down because this will prevent a cooling down run in which the lubricating oil and engine coolant safely carry away heat from the engine combustion chamber and bearings.

NOTICE

Make sure that the cause of the Emergency Stop is fully investigated and remedied before a fault Reset and generator set Start are attempted.

NOTICE

An Emergency Stop button is situated in close proximity to the operator panel viewing window.

6 Maintenance

WARNING

Automated Machinery

Accidental or remote starting of the generator set can cause severe personal injury or death. Make sure that the generator set cannot be started accidentally or remotely before starting work on the generator.

WARNING

Fall Hazard

Falls can result in severe personal injury or death. Make sure that suitable equipment for performing tasks at height are used in accordance with local guidelines and legislation.

WARNING

Mechanical Hazard

Failed components may be ejected or operate incorrectly which can cause severe personal injury or death. Do not climb the generator set; this may damage critical parts.

WARNING

Combustible Gases

Ignition of battery gases is a fire and explosion hazard which can cause severe personal injury or death. Do not smoke, or switch the trouble light ON or OFF near a battery. Touch a grounded metal surface first before touching batteries to discharge static electricity. Stop the generator set and disconnect the battery charger before disconnecting battery cables. Using an insulated wrench, disconnect the negative (-) cable first and reconnect it last.

WARNING

Electric Shock Hazard

Voltages and currents present an electrical shock hazard that can cause severe burns or death. Make sure that only personnel who are trained and experienced work with distribution voltages. Even after generator set shutdown, an electrical shock hazard may still exist, caused by induced or residual voltage within the alternator or cables. Some interfaces may display zero voltage even when voltages are present.

WARNING

Electrical Generating Equipment

Incorrect operation and maintenance can result in severe personal injury or death. Make sure that only suitably trained and experienced service personnel perform electrical and/or mechanical service.

NOTICE

Only authorized and qualified maintenance technicians, who are familiar with the equipment and its operation, should carry out maintenance.

NOTICE

Dependent upon the control system fitted, this unit may operate automatically and could start without warning.

NOTICE

Before carrying out any maintenance work, become familiar with [Section 1.3 on page 5](#), together with all the documentation supplied with the generator set.

NOTICE

Always disconnect a battery charger from its AC source before disconnecting the battery cables. Failure to do so can result in voltage spikes high enough to damage the DC control circuits of the generator set.

All maintenance tasks must be assessed for health and safety risks, the preventative measures identified must be actioned. Accompaniment is required for tasks where the presence of someone else will add significantly to the safety of the task.

Read, understand, and comply with all Caution and Warning notes in this section, those contained within [Chapter 1](#), and those contained within the documentation supplied with the generator set.

Ensure adequate lighting and staging (where required) are installed.

NOTICE

Before carrying out any maintenance work, lock the generator set out of service for safe working.

6.1 Locking the Generator Set Out of Service

Before any work is carried out for maintenance, etc., the generator set must be immobilized. Even if the generator set is put out of service by pressing the **Off** switch on the operator panel, the generator set cannot be considered safe to work on until the engine is properly immobilized, as detailed in the following procedures.

NOTICE

Refer also to the engine specific Operator Manual. This manual contains specific equipment instructions that may differ from the standard generator set.

6.1.1 Immobilizing for Safe Working

To immobilize the generator set:

1. Press the **Off** mode switch on the operator panel to shut down the generator set.
2. Press the **Emergency Stop button**. This prevents the generator set starting, regardless of the Start signal source and provides an additional safety step for immobilizing the generator set.

NOTICE
When the Emergency Stop button is pressed, the operator panel indicates a Shutdown condition. The red Shutdown status LED  illuminates and a message is displayed.

NOTICE
This condition is stored in the Fault History.

3. As an additional precaution, thoroughly ventilate the plant room before disconnecting any leads.
4. Isolate and lock off the supply to the heater, where fitted.
5. Isolate and lock off the supply to the battery charger, where fitted.
6. Isolate the fuel supply to the engine.
7. Using an insulated wrench, disconnect the negative (-) cable first on the starting batteries and control system batteries (if separate).
8. Fit warning notices at each of the above points to indicate Maintenance in Progress – Plant Immobilized for Safe Working.

6.2 Periodic Maintenance

The periodic maintenance procedures should be performed at whichever interval occurs first. At each scheduled maintenance interval, perform all previous maintenance checks that are due for scheduled maintenance.

The tabular data that follows gives the recommended service intervals for a generator set on Standby service. If the generator set will be subjected to Prime usage or extreme operating conditions, the service intervals should be reduced accordingly.

Some of the factors that can affect the maintenance schedule are:

- Use for continuous duty (prime power)
- Extremes in ambient temperature
- Exposure to elements
- Exposure to salt water
- Exposure to windblown dust or sand

Consult with an authorized distributor if the generator set will be subjected to any extreme operating conditions and determine if extra protection or a reduction in service intervals is needed. Use the running time meter to keep an accurate log of all service performed for warranty support. Perform all service at the time period indicated, or after the number of operating hours indicated, whichever comes first.

6.2.1 Periodic Maintenance Schedule

TABLE 19. PERIODIC MAINTENANCE SCHEDULE - ONE DAY TO ONE YEAR

Maintenance Items	See Engine Schedule	Daily or After 8 Hrs	Monthly or After 100 Hrs	6 Months or After 250 Hrs	1 Year
Perform maintenance tasks as specified using Daily or Hourly periods - whichever is sooner					

General set inspection	X ¹	X ²			
Check engine oil level		X			
Check coolant level		X			
Check coolant heater(s)		X			
Check battery charging system			X		
Check all hardware (fittings, clamps, fasteners, etc.)			X		
Check battery electrolyte level			X		
Check generator air outlet			X		
Check radiator hoses for wear and cracks				X	
Test rupture basin leak detect switch					X ³
Check drive belt	X ¹				
Check air cleaner (replace as necessary)	X ¹				
Drain fuel filter(s)	X ¹				
Check anti-freeze and DCA concentration	X ¹				
Replace engine oil and filter	X ¹				
Replace water coolant filter	X ¹				
Clean crankcase breather	X ¹				
Replace fuel filter	X ¹				
Clean cooling systems	X ¹				

1. Refer to Cummins QSX15 Series Engine Operation and Maintenance Manual for maintenance interval and/or procedure
2. Check for oil, fuel, coolant, and exhaust system leaks. Check exhaust system audibly and visually with the generator set running.
3. Check leak detect switch in sub-base fuel tank of optional enclosure, once a year or as required by safety code. Contact your authorized service center.

6.3 Maintenance Procedures - Daily or When Refueling

Monitor fluid levels, oil pressure, and coolant temperature frequently. During operation, be alert for mechanical problems that could create unsafe or hazardous conditions. The following sections cover several areas that should be frequently inspected for continued safe operation.

NOTICE

Components that have guards against inadvertent touching must be visually inspected only. Do not remove the guards to do the inspection.

6.3.1 General Information

Preventive maintenance begins with day-to-day awareness of the condition of the generator set. Before starting the generator set, check and look for:

- Oil and coolant levels
- Leaks
- Loose or damaged parts
- Worn or damaged belts
- Any change in engine noise or performance
- Generator set appearance

6.3.2 Engine Operation Report

The engine must be maintained in good mechanical condition if the operator is to obtain optimum satisfaction from its use. Running reports are necessary to enable programmed or emergency servicing to be carried out.

Comparison and intelligent interpretation of the running report, together with a practical follow-up action will eliminate most failures and emergency repairs.

Most engine problems give an early warning. Look and listen for changes in engine performance, sound, or appearance that can indicate service or repair is needed. Some engine changes to look for and report on are:

- Low lubricating oil pressure
- Low power
- Abnormal water or oil temperature
- Unusual engine noise
- Excessive use of coolant, fuel or lubricating oil
- Any coolant, fuel, or lubricating oil leaks
- Misfire

- Unexplained frequency fluctuation
- Significant vibration
- Excessive white and/or black exhaust smoke.

6.4 Cooling System

NOTICE

Loss of coolant can allow the engine to overheat if it does not have the protection of a shutdown device. This can cause severe damage to the engine. Maintain coolant level for proper operation of high engine temperature shutdown system. If applicable, see the Model Specifications section for more information.

6.4.1 Water Quality Check

Excessive levels of calcium and magnesium contribute to scaling problems, and excessive levels of chloride and sulfate cause cooling system corrosion. If water quality is unknown, it can be tested with the Fleetguard® Monitor C™ program or Water-Chek™ test strip. Water test results can also be obtained from local water utility departments. Test data must show the following elements, and the levels must not exceed the published limits for use in cooling systems.

Calcium, Magnesium (Hardness) Maximum level 170 ppm (as CaCO₃)

Chloride 40 ppm (as Cl)

Sulfate 100 ppm (as SO₄)

Fleetguard® Water-Chek™ Test Strip, Part Number CC2609, can be used to determine the quality of make-up and shop tap water. The Water-Chek™ test strip measures hardness, pH, and chloride levels in make-up water.

For additional information or advice refer to your local distributor.

6.4.2 Coolant Level Check - Introduction

WARNING

Fall Hazard

Falls can result in severe personal injury or death.

Make sure that suitable equipment for performing tasks at height are used in accordance with local guidelines and legislation.

WARNING

Hot Pressurized Liquid

Contact with hot liquid can cause severe burns.

Do not open the pressure cap while the engine is running. Let the engine cool down before removing the cap. Turn the cap slowly and do not open it fully until the pressure has been relieved.

⚠ CAUTION***Hazardous Liquid***

Prolonged or repeated skin contact can cause severe personal injury.
Avoid prolonged or repeated skin contact. Comply with all local health and safety regulations/codes during handling or disposal.

NOTICE

Do not add cold coolant to a hot engine, damage to the engine can occur, allow the engine to cool to below 50 °C (122 °F) before adding coolant.

NOTICE

Never use a sealing additive to stop leaks in the coolant system. This can result in a blocked coolant system and inadequate coolant flow causing the engine to overheat.

NOTICE

On applications that use a coolant recovery system, check to make sure the coolant is at the appropriate level on the coolant recovery tank dependent on engine temperature. Fill the cooling system with coolant to the bottom of the fill neck in the radiator or expansion tank, with the coolant temperature at 50 °C (122 °F) or lower.

NOTICE

Some radiators have two fill necks, both of which must be filled. Refer to the generator set specific drawings supplied with the set.

Coolant level must be checked daily.

Top up the cooling system with premixed fully formulated coolant or with a 50/50 mixture of high-quality water distilled or deionized and fully formulated concentrated antifreeze. The fully formulated coolant/antifreeze, either ethylene glycol or propylene glycol, must meet Cummins Engineering Standard 14603. Cummins Inc. recommends using Fleetguard® coolants containing DCA4. If the radiators are not filled using Fleetguard "Compleat" brand antifreeze or equivalent antifreeze, the DCA4 needs to be added to the cooling systems. If water quality is unknown, it can be tested with the Fleetguard® Monitor C™ program or Water-Chek™ test strip.

6.4.2.1 Coolant Level - Check

⚠ WARNING***Scalding***

Do not remove the radiator cap from a hot engine; Failure to do so can result in personal injury from heated coolant spray or steam.

Wait until the temperature is below 50 °C (122 °F) before removing pressure cap. Remove filler cap slowly to release coolant system pressure.

⚠ CAUTION***Skin Infection***

Avoid prolonged or repeated skin contact with antifreeze to prevent skin infections.
Comply with all local health and safety regulations/codes when handling or disposing of antifreeze.

⚠ CAUTION

Cold coolant.

Engine castings can be damaged.

Do not add cold coolant to a hot engine, allow the engine to cool to below 50 °C (122 °F) before adding coolant.

NOTICE

Never use a sealing additive to stop leaks in the coolant system. This can result in a blocked coolant system and inadequate coolant flow causing the engine to overheat.

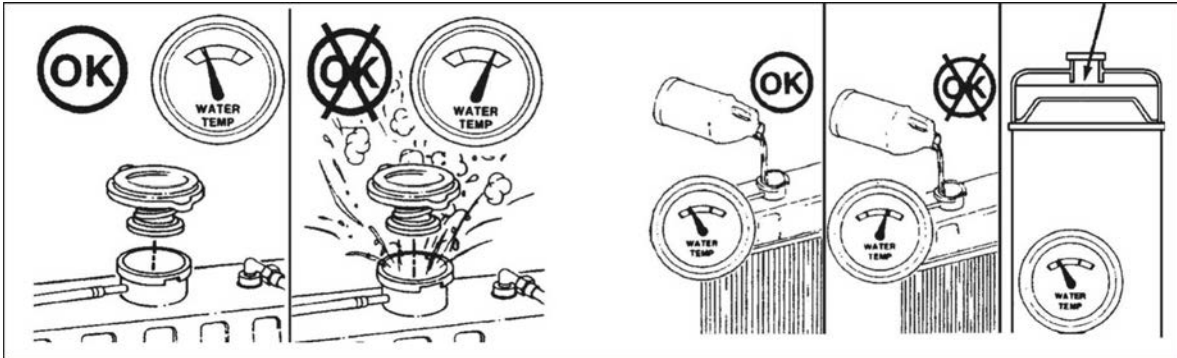

FIGURE 32. COOLANT LEVEL PROCEDURE

Coolant level must be checked daily. The standard coolant concentration is 50% Ethylene Glycol and water, this concentration must be maintained. Warranty claims for damage will be rejected if the incorrect mix of anti-freeze has been used. Consult your authorized distributor for the correct anti-freeze specifications and concentration for your operating conditions. The recommended antifreeze is Fleetguard® Compleat ES which is a low-silicate antifreeze, or its equivalent.

NOTICE

On applications that use a coolant recovery system, check to make sure the coolant is at the appropriate level on the coolant recovery tank dependent on engine temperature.

Fill the cooling system with coolant to the bottom of the fill neck in the radiator or expansion tank, with the coolant temperature at 50 °C (122 °F) or lower.

NOTICE

Some radiators have two fill necks, both of which must be filled. Refer to the generator set specific drawings supplied with the set.

6.4.3 Drive Belt - Inspection

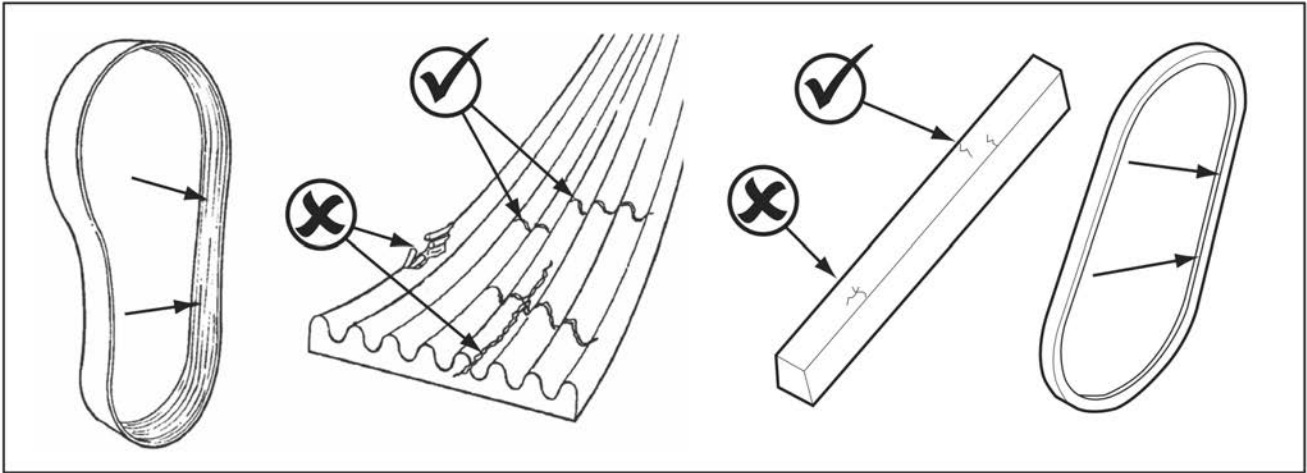

FIGURE 33. DRIVE BELT INSPECTION

Visually inspect the belt through the guarding.

Check for:

- Intersecting cracks. Small transverse (across the belt width) cracks are acceptable. Longitudinal (direction of belt length) cracks that intersect with transverse cracks are NOT acceptable.
- Frays or pieces of material missing.
- Glazed or cracked side walls.
- Uneven wear on sidewalls of belt.

NOTICE

Do not mix old and new V-belts on the same drive.

Contact your authorized distributor to have worn belts replaced.

Visually inspect sheaves through the guarding.

Check for:

- Damaged or worn grooves.
- Breaks on flanges of grooves.
- Frays or pieces of material missing.
- Glazed or cracked side walls.
- Uneven wear on sidewalls of belt.

NOTICE

V-Belts should never ride in the bottom of the groove. Damaged or worn grooves should not be used.

NOTICE

Keep foreign materials away from sheaves and belts as this may cause belt slip.

Contact your authorized distributor to have worn sheaves replaced.

6.4.4 Radiator Check

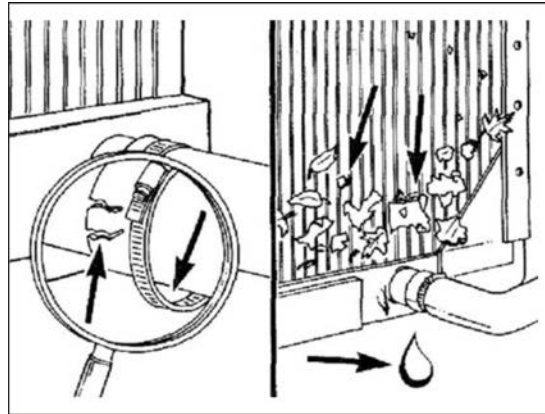

FIGURE 34. RADIATOR CHECK

Check for damaged hoses and loose and damaged hose clamps.

Inspect the exterior of the radiator (through the guarding) for obstructions. During the service life of a radiator a buildup of foreign matter can obstruct the flow of air through the radiator cores, reducing the cooling capability. To continue the efficiency of the radiator, the core will require cleaning.

Cleaning of the radiator core must only be undertaken by suitably trained and experienced service personnel.

6.4.5 Cooling Fan - Inspection

⚠ WARNING

Moving Parts

Moving parts can cause severe personal injury.

Use extreme caution around moving parts. All guards must be properly fastened to prevent unintended contact.

NOTICE

Never pull or pry on the fan, this can damage the fan blade(s) and cause fan failure.

A visual inspection of the cooling fan is required daily. Check for loose rivets or retaining bolts, for cracks, and bent or loose blades .

Do not operate the generator set with a damaged fan. Contact your authorized distributor for repair or replacement of a damaged fan.

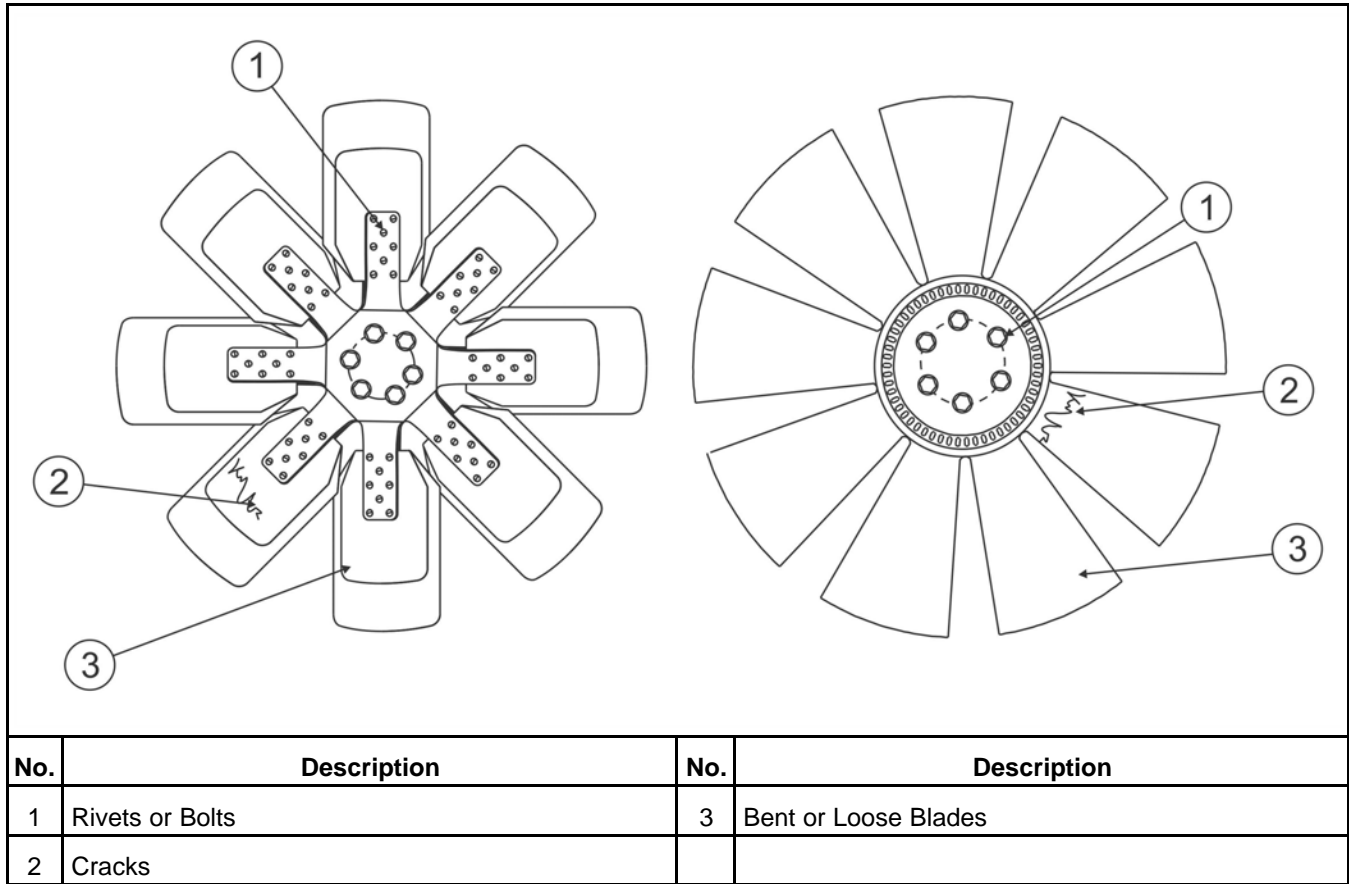

FIGURE 35. COOLING FAN INSPECTION CHECKPOINTS

6.5 Engine Oil

6.5.1 Engine Oil Level Check

⚠ WARNING

Hot Pressurized Liquid

Contact with hot liquid can cause severe burns.

Crankcase pressure can blow out hot oil. Do not check the oil while the generator set is operating.

⚠ CAUTION

Hazardous Liquid

Prolonged or repeated skin contact can cause severe personal injury.

Avoid prolonged or repeated skin contact. Comply with all local health and safety regulations/codes during handling or disposal.

NOTICE

Do not operate the engine with the oil level below the low mark or above the high mark. Overfilling can cause foaming or aeration of the oil while operation below the low mark may cause loss of oil pressure.

NOTICE

Use high-quality multi-viscosity lubricating oil such as Cummins Premium Blue® or its equivalent. Consult your authorized distributor for the correct lubricating oil specifications for your operating conditions.

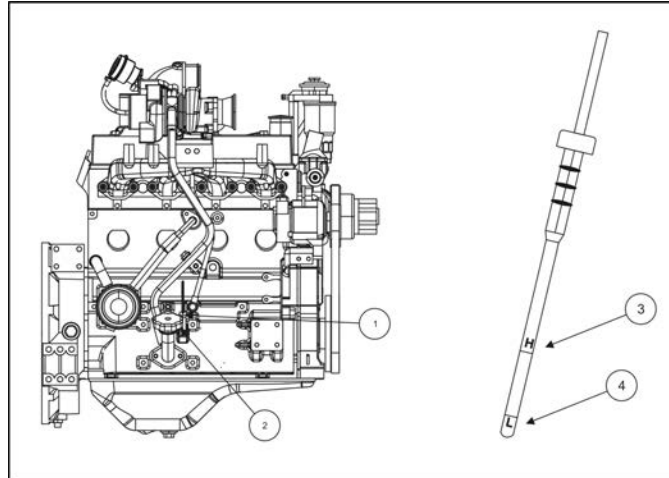

FIGURE 36. OIL LEVEL CHECK

The engine oil level must be checked daily before starting the engine, when the generator set is not running.

Never operate the engine with the oil level below the L (Low) mark (4), or above the H (High) mark (3).

1. Remove the dipstick (1) and with a lint free cloth wipe the dipstick clean.
2. Fully replace the dipstick.
3. Remove the dipstick and check the level of oil against the High and Low marks on the dipstick.
4. Top up to the High mark (3) if necessary with the correct grade of oil for your application.
 - a. Remove the filler cap (2).
 - b. Place a lint free cloth beneath or around the oil filler neck to minimize spillage.
 - c. Where possible use a funnel to help pour the new engine oil into the oil filler neck to the correct level.
 - d. Using the dipstick check the oil level, do not overfill the system. If more oil is needed then continue to fill with oil until the correct level is reached. If the level is too high then some of the oil will need to be drained of, refer to the engine operator and maintenance manual.
 - e. Replace the dipstick and oil filler cap.
 - f. Remove the lint free cloth, start the engine and allow to idle for five minutes, switch the engine off wait five minutes to allow the oil to drain back to the oil pan.
 - g. Check the oil level. Repeat steps (1-5) if oil needs to be added.

Clean up any spillage and dispose of materials in accordance with local regulations.

6.5.2 Oil Fill

NOTICE

Before carrying out any maintenance, isolate all supplies to the generator set and any control panels. Render the set inoperative by disconnecting the battery.

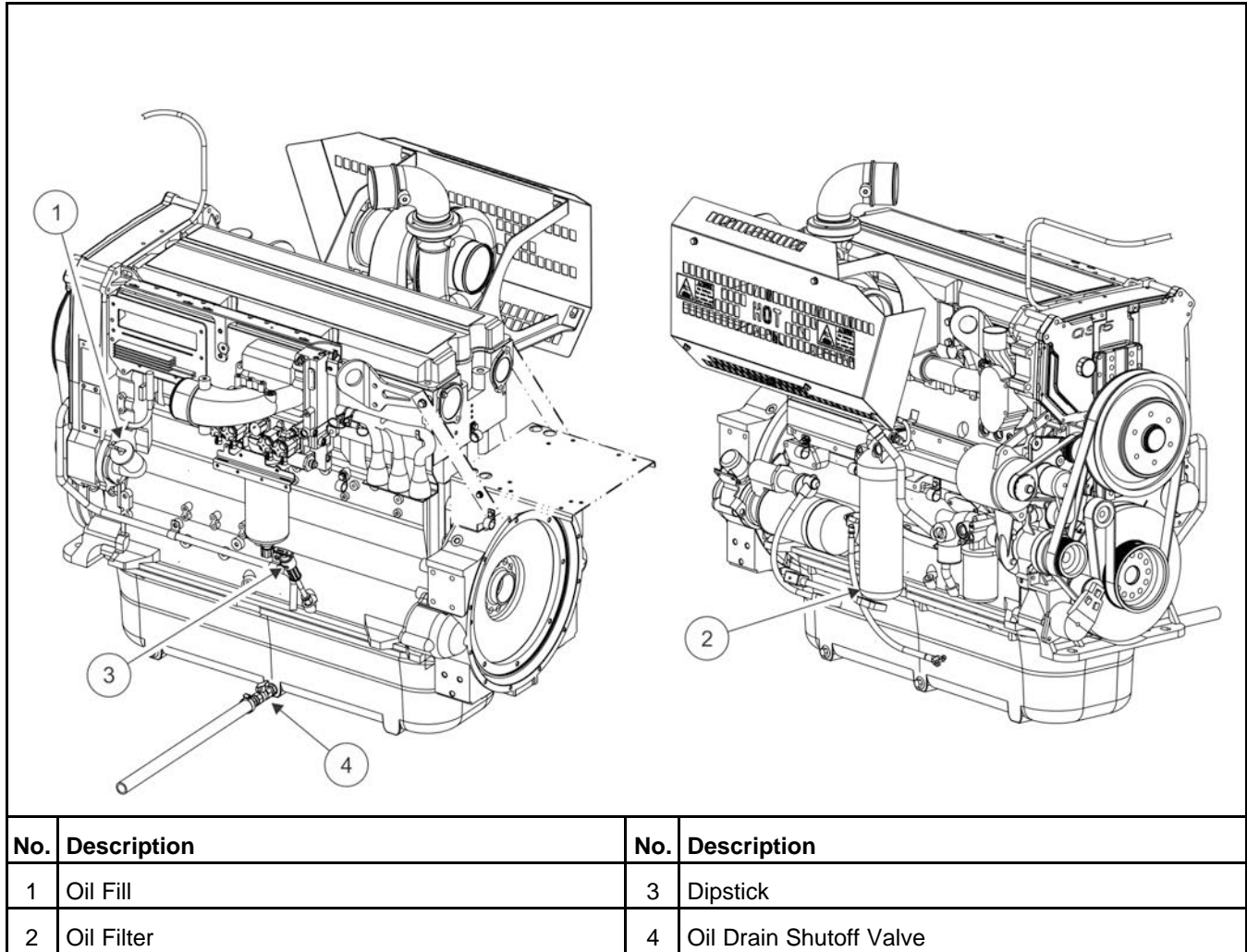

FIGURE 37. ENGINE OIL FILL LOCATION

1. Complete lock out procedure to ensure safe working environment.
2. Refer to the Engine Operation & Maintenance Manual for the correct grade of oil to be used. Or consult your authorized distributor for the correct lubricating oil for your operating conditions.
3. Fill the engine to the correct level with clean engine oil.
4. Check the oil level on the dipstick. The level must be on the high (H) mark on the dipstick. **Do Not Overfill.**

NOTICE

If the oil level is exceeded, drain off excess oil.

5. Return the generator set to the proper operating conditions.
6. Operate the generator set at idle speed and check for leaks.
7. Shut down the generator set.
8. Wait approximately 5 minutes to allow the oil to drain from the upper parts of the engine.
9. Rectify any leaks.
10. Check the oil level.
11. Add oil as necessary to bring the oil level to the high (H) mark on the dipstick.
12. Dispose of waste material in accordance with local regulations.

6.6 Fuel System

⚠ WARNING**Combustible Liquid**

Diesel fuel is a fire and explosion hazard which can cause severe personal injury or death. Do not permit any open flame, or other igniter near the fuel system, or in areas sharing ventilation.

⚠ WARNING**Combustible Liquid**

Mixing gasoline or alcohol with diesel fuel is an explosion hazard which can result in severe personal injury or death. Do not mix gasoline or alcohol with diesel fuels.

NOTICE

Engine fuel actuators can operate at voltages up to 140 volts DC.

NOTICE

Due to the precise tolerances of diesel injection systems, it is extremely important that the fuel be kept clean and free of dirt or water. Dirt or water in the system can cause severe damage to both the injection pump and the injection nozzles.

Use ASTM No. 2D fuel with a minimum Cetane number of 40. No. 2 diesel fuel gives the best economy and performance under most operating conditions. Fuels with Cetane numbers higher than 40 are often needed in high altitudes, or extremely low ambient temperatures, to prevent misfires and excessive smoke. Contact your authorized distributor for your operating conditions.

NOTICE

A diesel fuel to BS 2869:2010+A1:2011 (Fuel oils for agricultural, domestic, and industrial engine and boilers. Specification), conforming to the requirements and test methods of that specification would be an acceptable alternative to ASTM No. 2D.

6.6.1 Fuel Level

To avoid condensation problems, keep fuel supply tanks as full as possible by filling up each time the engine is used. Condensation (water) can cause clogging of the fuel filters as well as possible freezing problems. In addition, water mixing with the sulfur in the fuel forms acid which can corrode and damage engine parts.

NOTICE

When filling the generator set fuel tank, make sure the fuel filler cap breather is not blocked. If the fuel cap breather is blocked it can cause air intake into the fuel tank to be erratic. Make sure the fuel filler cap is cleaned after each fill.

6.6.2 Fuel/Water Separator Drain

Fuel/water separators provide protection for the engine fuel injection system, as water-free fuel supplies cannot be guaranteed.

Drain the water and sediment from the separator daily. The fuel filters can be inspected for collected water by checking the clear bowl at the bottom of each filter.

To drain the water:

1. Shut off the engine.
2. Place a suitable container under the fuel filter.
3. With the fuel supply valve closed, open the vent cap to break the airlock in the filter.
4. Turn the valve counterclockwise until the valve drops down about one inch (25 mm). Accumulated water will drain first. Drain the filter sump of water until clear fuel is visible.
5. When fuel begins to flow out of the drain, push the valve up and turn the valve clockwise to close the drain valve.
6. Before starting the engine, be sure to open the fuel supply valve.
7. If more than 2 oz (60 ml) is drained, refilling of the filter is required to prevent hard starting.

NOTICE

Do not over tighten the valve. Over tightening can damage the threads.

NOTICE

If more than 2 oz (60 ml) is drained, refilling of the filter is required to prevent hard starting.

The drained liquids must be disposed of in accordance with local environmental regulations.

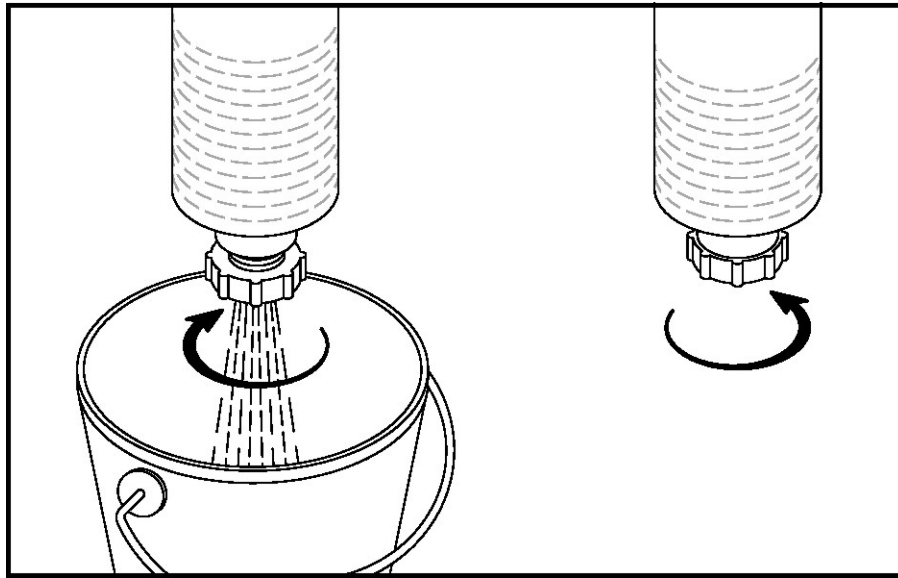

FIGURE 38. DRAINING THE FUEL/WATER SEPARATOR

6.7 Hoses and Fuel Lines - Check

⚠ WARNING

Moving Parts

Moving parts can cause severe personal injury.

Use extreme caution around moving parts. All guards must be properly fastened to prevent unintended contact.

⚠ WARNING

Hot Surfaces

Contact with the hot surfaces can cause severe burns.

Avoid contact with hot parts. Allow hot parts to completely cool.

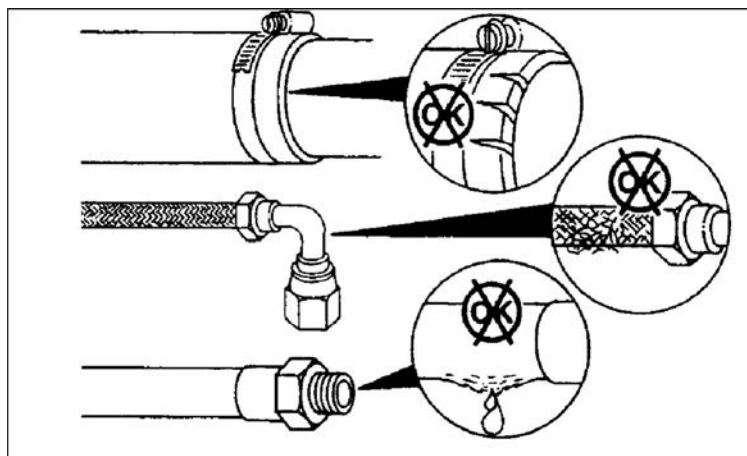

FIGURE 39. HOSES AND FUEL LINE INSPECTION

While the generator set is in operation, visually inspect the fuel lines, filters, and fittings for leaks. Check any flexible sections for cuts, cracks and abrasions and make sure they are not rubbing against anything that could cause breakage. If any leaks are detected, shut down the generator set (if possible). Contact your authorized distributor and have the leaks repaired immediately.

6.8 Air Intake System

The direct flow air cleaner consists of a primary filter and a secondary filter within the air cleaner housing. The air cleaner has been designed for a maximum restriction, at which point the filter elements should be changed. Refer to the Model Specifications section.

6.8.1 Air Cleaner Service Indicator

Check the air cleaner service indicator. If the gauge has crossed the red mark, replace the filter.

⚠ WARNING

Exhaust components become very hot when the generator set is in use and remain hot for a period of time after the generator set has been shut down. These components can cause severe personal injury or death from contact. Allow these components to cool completely before performing any maintenance tasks.

⚠ WARNING

Moving parts can cause severe personal injury or death. Use extreme caution around hot manifolds, moving parts, etc.

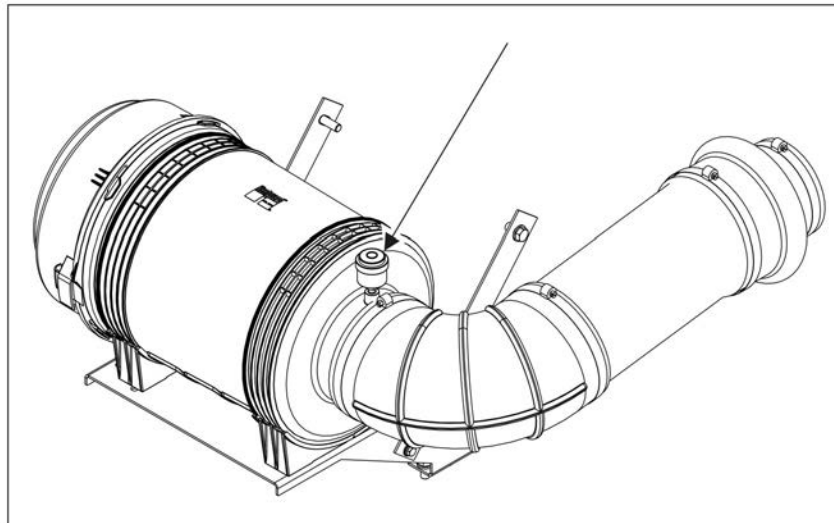

FIGURE 40. AIR CLEANER SERVICE INDICATOR

6.8.2 Normal Duty Air Cleaner

6.8.2.1 Air Cleaner Element Removal

Normal duty air cleaners combine centrifuge cleaning with element filtering before air enters the engine.

NOTICE

Holes, loose-end seals, dented sealing surfaces, corrosion of pipes, and other forms of damage render the air cleaner inoperative and require immediate element replacement or engine damage can occur.

NOTICE

Cummins does not recommend cleaning paper-type air cleaner elements. Elements that have been cleaned will clog, and airflow to the engine will be restricted.

1. Before disassembly, wipe dirt from the cover and the upper portion of the air cleaner.
2. Loosen the wing bolt (2) and remove the band clamp securing the dust pan (1).
3. Remove the dust shield (3) from the dust pan (1).
4. Clean the dust pan and shield.
5. Remove the wing nut (5) that secures the air cleaner element (4) in the air cleaner housing.
6. Inspect the rubber sealing washer on the wing nut.
7. Remove the dirty cleaner element (4). Dispose of the dirty element in accordance with local environmental agency requirements.

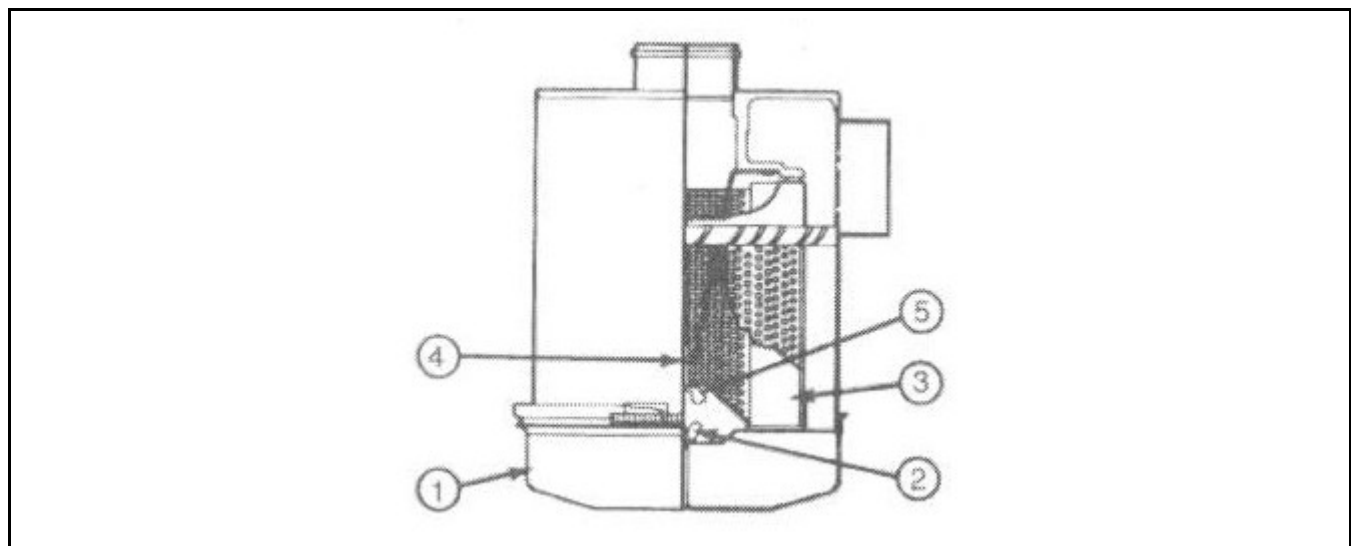

No.	Description	No.	Description
1	Dust Pan	4	Air Cleaner Element
2	Wing Bolt	5	Wing Nut
3	Dust Shield		

FIGURE 41. NORMAL DUTY AIR CLEANER

6.8.2.2 Air Cleaner Element Installation

1. Install the air cleaner element (4) in the air cleaner housing.
2. Inspect the rubber sealing washer and make sure it is in place under the wing nut (5).
3. Tighten the wing nut (5) that secures the element (4) in the air cleaner housing.
4. Assemble the dust shield (3) and the dust pan (1).
5. Position the dust shield (3) and dust pan (1) on the air cleaner housing and secure them with the band clamp wing bolt (2).

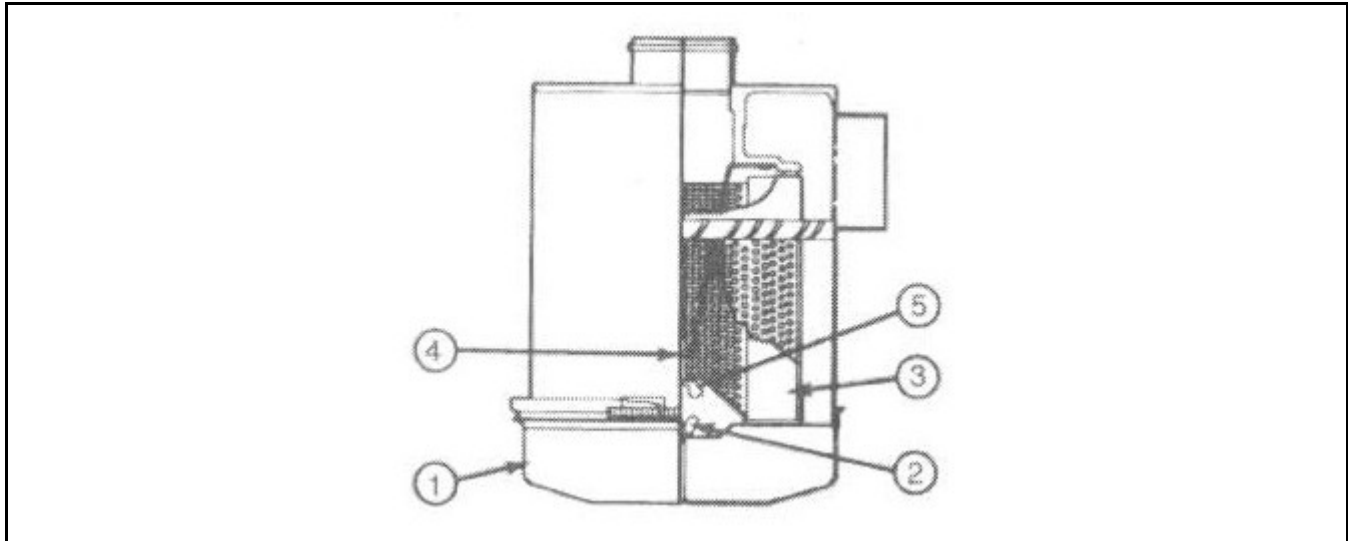

No.	Description	No.	Description
1	Dust Pan	4	Air Cleaner Element
2	Wing Bolt	5	Wing Nut
3	Dust Shield		

FIGURE 42. NORMAL DUTY AIR CLEANER

6.8.3 Heavy Duty Air Cleaner

6.8.3.1 Heavy Duty Air Cleaner Element Removal

Heavy duty air cleaners combine centrifuge cleaning with element filtering before air enters the engine.

NOTICE

Cummins does not recommend cleaning paper-type air cleaner elements. Elements that have been cleaned will clog, and airflow to the engine will be restricted.

1. Before disassembly, wipe dirt from the cover and the upper portion of the air cleaner.
2. Loosen the wing bolt (1) and remove the band clamp securing the dust pan (2).
3. Remove the dust shield (4) from the dust pan (2).
4. Clean the dust pan and shield.
5. Loosen the wing bolt (3).

6. Remove the wing nut (5) that secures the air cleaner primary element (6) in the air cleaner housing.
7. Inspect the rubber sealing washer on the wing nut.
8. Remove the dirty cleaner element (6). If the inner safety element (8) is being replaced based upon high intake restriction, remove the wing nut (7) and replace the inner safety element. Dispose of the dirty element in accordance with local environmental agency requirements.

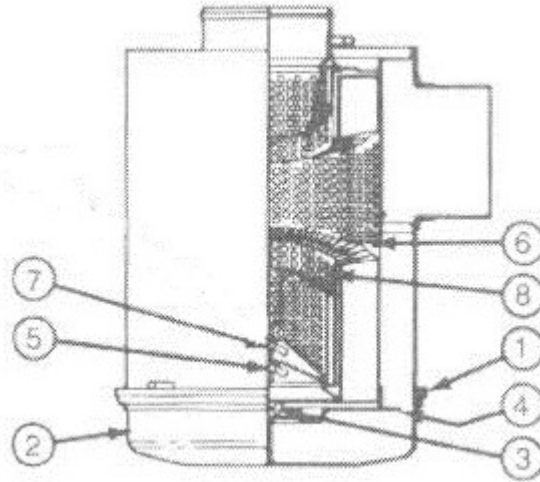

No.	Description	No.	Description
1	Wing Bolt	5	Wing Nut
2	Dust Pan	6	Air Cleaner Primary Element
3	Wing Nut	7	Wing Nut
4	Dust Shield	8	Air Cleaner Inner Safety Element

FIGURE 43. HEAVY DUTY AIR CLEANER

6.8.3.2 Heavy Duty Air Cleaner Element Installation

1. If the inner safety element (8) is being replaced, install the safety element and secure it with the wing nut (7).
2. Check the seals.
3. Install the air cleaner primary element (6) in the air cleaner housing.
4. Inspect the rubber sealing washer on the wing nut (5).
5. Tighten the wing nut to sure the primary element in the air cleaner housing.
6. Install the dust shield (4) into the dust pan (2).
7. Install the dust shield and dust pan assembly and secure them using the band clamp and tighten the wing bolt (1).
8. Tighten the wing bolt (3).

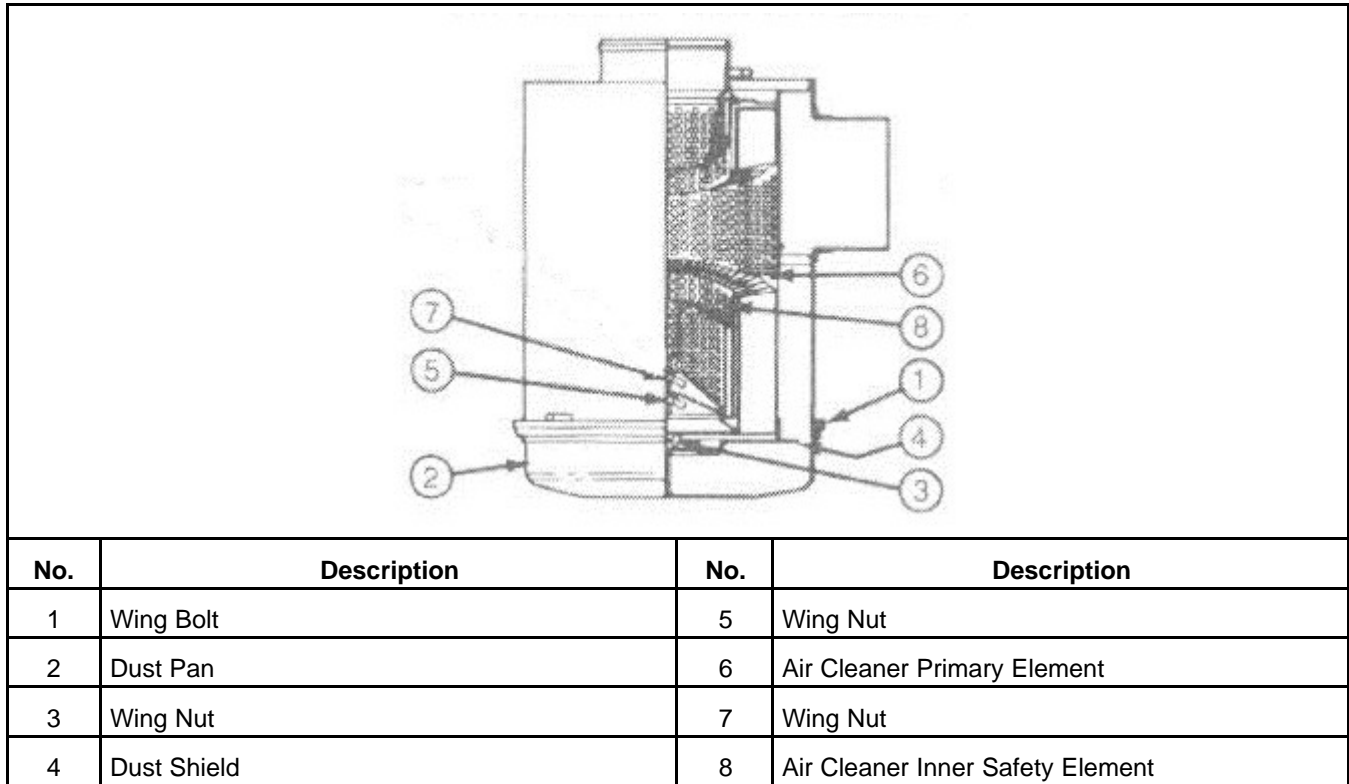

FIGURE 44. HEAVY DUTY AIR CLEANER

6.8.3.3 Heavy Duty Air Cleaner Maintenance

⚠ WARNING

Fall Hazard
Falls can result in severe personal injury or death.
Make sure that suitable equipment for performing tasks at height are used in accordance with local guidelines and legislation.

There is a dust ejector valve (DEV) on the bottom of each filter pre-cleaner that should be checked periodically to make sure it is free of dust and dirt.

When there is a filter pre-cleaner, it includes a primary and secondary element that is checked periodically to make sure they are clean. Refer to the *Periodic Maintenance Schedule* table for additional information.

6.9 Exhaust System

⚠ WARNING

Hot Surfaces
Contact with the hot surfaces can cause severe burns.
Avoid contact with hot parts. Allow hot parts to completely cool.

⚠ WARNING***Moving Parts***

Moving parts can cause severe personal injury.

Use extreme caution around moving parts. All guards must be properly fastened to prevent unintended contact.

⚠ WARNING***Toxic Gases***

Substances in exhaust gases have been identified by some state and federal agencies to cause cancer or reproductive toxicity.

Do not breathe in or come into contact with exhaust gases.

While the generator set is in operation, inspect the entire exhaust system visually and audibly including the exhaust manifold, muffler, and exhaust pipe without removing guarding and panels. Check for leaks at all connections, welds, gaskets and joints, and make sure that exhaust pipes are not heating surrounding areas excessively. If any leaks are detected, shut down the generator set (if possible). Contact your authorized distributor and have the leaks repaired immediately.

6.10 Generator Set Output - AC Electric System

Check the following while the generator set is operating:

- **Frequency:** The generator set frequency should be stable and the reading should be the same as the generator set nameplate rating (50 Hz / 1500 RPM or 60 Hz / 1800 RPM).
- **AC Voltage:** At no load, the line-to-line voltage, or voltages, should be the same as the generator set nameplate rating.
- **AC Ammeter:** At no load, the current readings should be zero. With a load applied, each line current should be similar.
- **Panel Lamps:** When the Operating Panel is first connected to the DC supply, the system runs a check, illuminating each of the indicator lamps in turn.

6.11 DC Electrical System

⚠ WARNING***Combustible Gases***

Ignition of battery gases is a fire and explosion hazard which can cause severe personal injury or death.

Do not smoke, or switch the trouble light ON or OFF near a battery. Touch a grounded metal surface first before touching batteries to discharge static electricity. Stop the generator set and disconnect the battery charger before disconnecting battery cables. Using an insulated wrench, disconnect the negative (-) cable first and reconnect it last.

1. Check the harness connections. If any harness connections are damaged, contact your service representative.

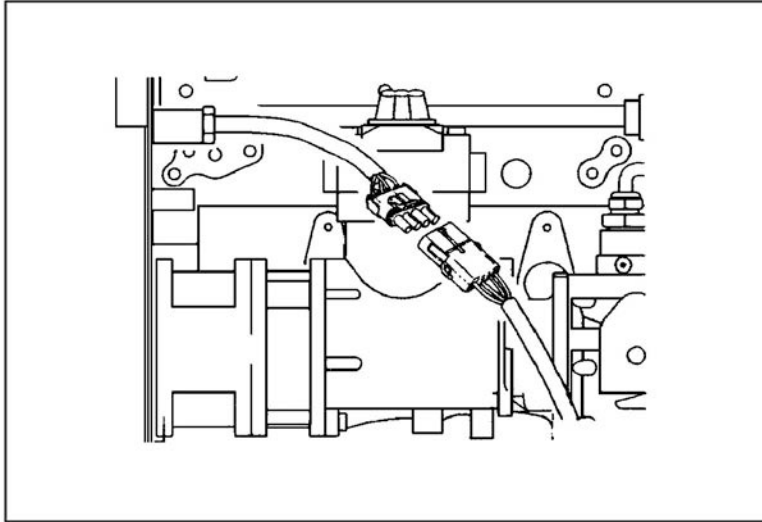

FIGURE 45. CHECK HARNESS CONNECTIONS

2. Check the terminals on the batteries for clean and tight connections. Loose or corroded connections create resistance, which can hinder starting. Clean and reconnect the battery cables if loose, using an insulated wrench. Always disconnect both ends of the negative battery cable. Reconnect one end of the cable to the negative battery terminal and the other end to ground. This will make sure that any arcing will be away from the battery and least likely to ignite explosive battery gases.
3. Check connections at the battery charging alternator.
4. Visually inspect the alternator belt to make sure it is not loose or cracked.

6.12 Batteries

Batteries are an essential part of any standby generator system. Roughly 90% of all generator failures are due to batteries.

It is important that batteries are stored, commissioned, and maintained as detailed here. Refer also to the Battery Manufacturer's instructions.

Always use correct handling techniques when moving or lifting batteries. Batteries can be heavy and may require more than one person to lift and a suitable trolley for transportation.

Batteries are usually supplied with the generator in 'dry-charged' form. In order to commission dry-charged lead-acid batteries, pre-mixed electrolyte of the correct type and specific gravity must be added to the cells of the battery.

Maintenance free batteries supplied with the generator need no maintenance for commissioning.

6.12.1 Storage

Batteries must be stored in a cool, dry, well-ventilated place, in the upright position, and with the vent caps securely in place.

Batteries must never be stacked on top of each other and must be protected from the floor by a wooden pallet or suitably thick cardboard sheet.

6.12.2 Safety Precautions

Servicing of batteries are to be performed or supervised by personnel knowledgeable of batteries and the required precautions. Keep unauthorized personnel away from batteries.

6.12.2.1 General Precautions

WARNING

Combustible Gases

Ignition of battery gases is a fire and explosion hazard which can cause severe personal injury or death.

Laying tools or metal objects across the battery can cause arcing. Never lay tools or metal objects across the top of the battery.

CAUTION

Electrical Shock

A battery presents a risk of electrical shock and high short circuit current which can cause minor or moderate injury.

Observe the following precautions when working on batteries.

- Use proper PPE. Remove jewelry such as watches, rings, or other metal objects. Remove any conductive items from pockets. These items can fall into equipment and result in a short circuit, which can cause shock or burning. Refer to local standards for PPE details (in the U.S: see NFPA 70).
- Keep batteries upright to prevent spillage. Electrolyte is a dilute sulphuric acid that is harmful to the skin and eyes.
- Use tools with insulated handles to prevent the risk of electric shock.

6.12.2.2 Fire Hazard

NOTICE

During the charging of a battery, explosive gases are given off. Keep the battery area well ventilated and away from naked flames and sparks. Do not smoke.

- Before disconnecting a battery, isolate the utility powered battery charger (where fitted).
- To disconnect the battery, use an insulated wrench to disconnect the negative cable first.
- To connect the battery, use an insulated wrench to connect the negative cable last.

6.12.2.3 Fluid Hazard

WARNING

Toxic Hazard

Contact with electrolyte can cause severe personal injury.

Wear appropriate PPE when handling electrolyte: acid-proof protective apron, goggles, rubber gloves and boots. If electrolyte is splashed on the skin or in the eyes, flush the affected areas immediately with water and seek medical attention.

WARNING

Hazardous Liquid

Uncontrolled chemical reactions can cause severe chemical burns or death.

Never add undiluted sulfuric acid to a battery.

6.12.3 Battery Maintenance

WARNING

Combustible Gases

Ignition of battery gases is a fire and explosion hazard which can cause severe personal injury or death.

Do not smoke, or switch the trouble light ON or OFF near a battery. Touch a grounded metal surface first before touching batteries to discharge static electricity. Stop the generator set and disconnect the battery charger before disconnecting battery cables. Using an insulated wrench, disconnect the negative (-) cable first and reconnect it last.

NOTICE

To prevent dangerous arcing, always disconnect the negative (-) ground cable from the battery using an insulated wrench before working on any parts of the electrical system or the engine. Before touching batteries, discharge static electricity from body by first touching a grounded metal surface.

NOTICE

Always disconnect a battery charger from its AC source before disconnecting the battery leads. Failure to do so can result in voltage spikes high enough to damage the DC control circuits of the generator set.

NOTICE

Maintenance-free batteries are sealed and do not require the addition of electrolyte. Some manufacturers of maintenance-free batteries provide an 'eye' or some visible means of telling when the battery is discharged or approaching the end of its useful life.

Batteries require attention at all times, even when not working. A battery will not last if it is neglected. Maintenance is carried out as follows:

1. Keep the battery and the battery area clean and dry. If fitted, make sure that the vent caps are securely screwed down, or pushed home.
2. To avoid contamination of the battery, clean it only when the vent plugs (if fitted) are in place.
3. Keep the battery terminals and connections free from corrosion by lightly coating them with petroleum jelly.
4. Secure the battery(s) to prevent movement and internal damage to plates.
5. Check the condition of the starting batteries. Refer to the Generator Set Maintenance table in [Section 6.2 on page 83](#) for the maintenance interval.

6.12.3.1 Cleaning Batteries

WARNING

Toxic Hazard

Contact with electrolyte can cause severe personal injury.

Wear appropriate PPE when handling electrolyte: acid-proof protective apron, goggles, rubber gloves and boots. If electrolyte is splashed on the skin or in the eyes, flush the affected areas immediately with water and seek medical attention.

Prevent a buildup of dirt or corrosion by wiping the batteries with a damp cloth. Use a solution consisting of 0.11 kg (1/4 lb) of baking soda added to 0.96 liters (1 quart) of water to neutralize any possible acid. Be sure the vent plugs (if fitted) are tight to prevent any cleaning solution from entering the cells.

After cleaning, make sure the battery and surrounding areas are dry.

After making connections, coat the terminals with a light application of petroleum jelly to retard corrosion. Keep the battery terminals clean and tight. A loose connection can reduce battery standby time and cause battery fires.

6.12.3.2 Charging

When generator sets are used infrequently, batteries must be re-charged monthly to maintain a fully-charged condition.

NOTICE

Never allow a battery to become completely flat (fully discharged), or to stand in a discharged condition, or damage will result.

1. Do not put a filled battery into storage without first giving the battery a commissioning charge.
2. Batteries must be given a further charge every six months at the normal initial charge rate until the voltage ceases to rise.

6.12.3.3 Trickle/Boost Charging (Option)

The battery will automatically receive a trickle-charge from the battery charger (when switched ON) to prevent the battery from becoming discharged below its optimum charge level.

During trickle-charging, not all cells in the battery receive the same charge. Over a period of several months, this may affect battery performance. It is, therefore, good practice to give batteries a regular charge at their full rate to return all cells to full capacity. This is referred to as boost-charging, or equalize-charging.

If the charger is fitted with a **Boost Charge** switch, the **Boost** position should be selected at intervals detailed by the battery manufacturer (normally around every 6 months).

NOTICE

Batteries should not be left on Boost Charge for extended periods as this results in excessive water consumption and gassing, and may impair battery performance.

A boost charge not exceeding twice the bench charge rate may be used, providing that:

- The electrolyte temperature does not exceed 43 °C (109 °F).
- The battery volts do not reach 15 V (for a 12 V battery).

If either of these situations arises, reduce the charge rate to the normal bench rate. For tropical climates the temperature must not exceed 49 °C (120 °F).

NOTICE

The charge period should be extended:

- **To 8 hours if the battery has been in storage for three months or more at temperatures in excess of 30 °C (86 °F), or if humidity is above 80%.**
- **To 12 hours if the battery has been in storage for twelve months or more.**

At the end of the charging process, the electrolyte levels must be checked and restored if necessary by the addition of electrolyte of the correct SG. The vent caps must then be replaced.

NOTICE

Any further topping-up of the electrolyte must be made using distilled or de-ionized water.

6.12.4 Electrolyte - Specific Gravity and Temperature

Maintenance-free batteries are sealed and do not require the addition of electrolyte. Some manufacturers of maintenance-free batteries provide an 'eye' or other visible means of telling when the battery is discharged or approaching the end of its useful life.

6.12.4.1 Checking Electrolyte Level

NOTICE

Never add tap or well water and never allow the battery electrolyte to drop below the top of the plates, otherwise damage will occur.

NOTICE

Do not add water in freezing weather unless the engine will run long enough (2 to 3 hours) to make sure that water and electrolyte are thoroughly mixed.

Check the level of the electrolyte (acid and water solution) in the batteries at least every month or 100 hours of operation, whichever occurs first. Maintain the electrolyte to the levels indicated on the battery label. Add distilled water only and recharge. Replace the vent plugs once filling is completed.

If a cell level is low, check the case for leaks.

Keep the battery case clean and dry. An accumulation of moisture will lead to a more rapid discharge and battery failure.

6.12.4.2 Checking Specific Gravity Using a Hydrometer

Use a hydrometer to check the specific gravity (SG) of the electrolyte in each battery cell.

Hold the hydrometer vertically and take the reading.

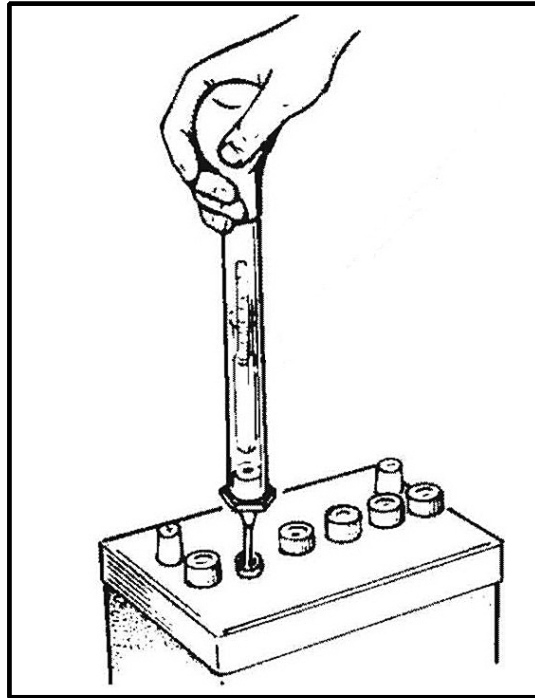

FIGURE 46. CHECKING SPECIFIC GRAVITY

6.12.4.3 Checking Specific Gravity Using an Acid Refractometer

Follow the instructions included with the refractometer. Obtain a small drop of liquid and place it under the clear plastic cover to check the specific gravity (SG) of the electrolyte in each battery cell.

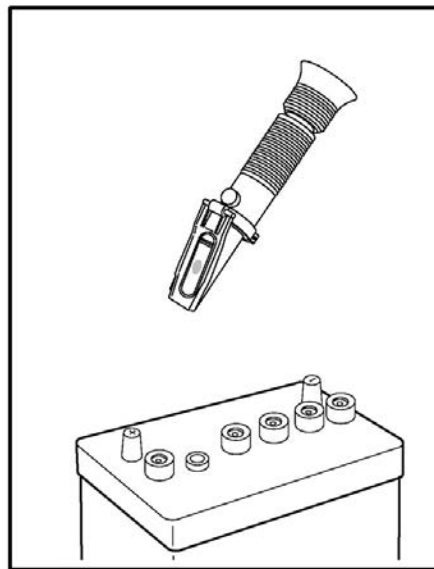

FIGURE 47. TYPICAL BATTERY ACID REFRACTOMETER

6.12.4.4 Specific Gravity Values for Batteries

A fully charged battery will have a corrected specific gravity (SG) of 1.260 at 25 °C (77 °F). Hold the hydrometer vertically and take the reading. Charge the battery if the reading is below 1.215. The table below shows the specific gravity of electrolyte, corrected to 25 °C (77 °F).

TABLE 20. SPECIFIC GRAVITY

Temperature	For Filling New Cells	At End of Charge
Ambient temperature normally below 32 °C (90 °F)	1.270	1.270–1.290
Ambient temperature frequently above 32 °C (90 °F)	1.240	1.240–1.260
Maximum permissible temperature of electrolyte during charge	45 °C (113 °F)	45 °C (113 °F)

Correct the specific gravity reading for other temperatures by subtracting seven gravity points (0.007) for every 10 °C (18 °F) when the electrolyte temperature is above 27 °C (80 °F). Apply the correction formula as follows:

- For every 10 °C (18 °F) above 25 °C (77 °F), subtract 0.007 (7 points)
- For every 10 °C (18 °F) below 25 °C (77 °F), add 0.007 (7 points)

For example: if the specific gravity at 25 °C (77 °F) is 1.260, then the specific gravity at 15 °C (59 °F) is 1.267.

6.12.5 Battery Replacement

WARNING

Combustible Liquid

Burning the battery may cause an explosion. Damage to the casing will release electrolytes which is harmful to the skin and eyes.

When disposing of a battery, do not mutilate or burn it. Comply with all local health and safety regulations/codes during handling or disposal.

Always replace the starting battery with the same number and type (e.g., vented, lead acid, maintenance free) as listed in the specifications section of this document. Properly dispose of battery in accordance with local environment agency requirements.

Always use correct handling techniques to lift and move a battery.

6.12.6 Battery Type Specification

TABLE 21. BATTERY SPECIFICATION

Electrical System	
Starting Voltage	24 Volts DC
Battery Group Number	8D
CCA (minimum) Cold Soak at -18 °C (0 °F)	1400A at -18–0 °C (0–32 °F)
Required Battery Quantity	Two 12 Volt

6.12.7 Battery Fault Finding

The following table shows some typical faults and their possible causes and remedies.

TABLE 22. FAULT FINDING

Symptom	Possible Fault	Remedy
Battery completely discharged	Poor battery terminal connection	Clean connections, replace and tighten.
	Charge alternator/ alternator connection fault	Contact your nearest Cummins distributor.
	Mains battery charger/ charger connections fault/ mains supply fault	Contact your nearest Cummins distributor.
	Blown fuse	Contact your nearest Cummins distributor.
	Battery fault	Contact your nearest Cummins distributor.
	Newly installed battery shipped dry	Fill with electrolyte and give commissioning charge.
Battery low charge	Poor battery connection	Clean connections, reconnect and tighten securely.
	Charge alternator/ alternator connection fault	Contact your nearest Cummins distributor.
	Mains battery charger/ charger connections fault	Contact your nearest Cummins distributor.
	Inequality in cell charge	Contact your nearest Cummins distributor.
	Battery fault	Contact your nearest Cummins distributor.
Battery overcharged	Charge alternator fault	Contact your nearest Cummins distributor.
	Mains battery charge fault	Contact your nearest Cummins distributor.
	Low battery fluid level	Check the charger; it may not be shutting off when the charge is complete.
Battery terminals getting hot	Poor battery connection	Clean connections, reconnect and tighten securely.
		Contact your nearest Cummins distributor.

7 Troubleshooting

Fault code information, together with warning and shutdown information, is provided in this section to assist in locating and identifying the possible causes of faults in the generator set system.

Refer also to the Operator's engine specific manual. The engine manual contains additional information regarding the running and care of the generator set as well as specific equipment instructions that may differ from the standard generator set.

7.1 Control System

The generator set control system continuously monitors engine sensors for abnormal conditions, such as low oil pressure and high coolant temperature. If any of these conditions occur, the control will light a yellow Warning lamp or a red Shutdown lamp and will display a message on the graphical display panel. In the event of an engine shutdown fault (red Shutdown LED), the control will stop the engine immediately.

7.2 Safety Considerations

WARNING

Hazardous Voltage

Contact with high voltages can cause severe electrical shock, burns, or death.

Make sure that only personnel who are trained and qualified to work on this equipment are allowed to operate the generator set and perform maintenance on it.

WARNING

Automated Machinery

Accidental or remote starting of the generator set can cause severe personal injury or death.

Make sure that the generator set cannot be started accidentally or remotely before starting work on the generator.

WARNING

Combustible Gases

Ignition of battery gases is a fire and explosion hazard which can cause severe personal injury or death.

Do not smoke, or switch the trouble light ON or OFF near a battery. Touch a grounded metal surface first before touching batteries to discharge static electricity. Stop the generator set and disconnect the battery charger before disconnecting battery cables. Using an insulated wrench, disconnect the negative (-) cable first and reconnect it last.

CAUTION

Hazardous Voltage

Contact with high voltages can cause severe electrical shock, burns, or death.

Isolate all external electrical supplies prior to access of the control panel. Internal components have live exposed terminations even when the generator set is not running.

NOTICE

Isolator switch only: Do not open the output box while the generator set is running as the isolator switch will cause the generator set to shut down. Keep the output box covers in place during troubleshooting.

NOTICE

Always disconnect a battery charger from its AC source before disconnecting the battery cables. Failure to do so can result in voltage spikes high enough to damage the DC control circuits of the generator set.

NOTICE

Ventilate the battery area before working on or near the battery. Wear goggles. Stop the generator set and disconnect the battery charger before disconnecting the battery cables using an insulated wrench. Disconnect the negative (-) cable first and reconnect it last.

All maintenance tasks must be assessed for health and safety risks; the preventive measures identified must be performed. An additional person is required for any task where doing so significantly adds to the safety of the task.

The installation of a generator set can be designed for remote starting. When troubleshooting a generator set that is shut down, make sure that the generator set cannot be accidentally re-started. Refer to the Locking the Generator Set Out of Service section.

7.3 Fault Finding

⚠ WARNING***Electrical Generating Equipment***

Incorrect operation and maintenance can result in severe personal injury or death.

Make sure that only suitably trained and experienced service personnel perform electrical and/or mechanical service.

NOTICE

Review safety precautions listed within [Chapter 1 on page 1](#) of this manual together with the documentation supplied with the generator set.

Should a fault condition occur during operation, follow the procedures in the following tables to locate and correct the problem. For any symptom not listed, contact your authorized distributor for assistance.

Before starting any fault finding, ensure that the following basic checks are carried out:

- All switches and controls are in their correct positions
- Fuel system is connected and fuel is available
- The lubricating oil level is correct
- The coolant level is correct
- The radiator matrix is free from obstruction
- The battery charge condition is satisfactory and the connections are secure
- The generator set electrics and alternator connections are secure

- The panel connections are secure
- The protection circuits have been reset
- Blown fuses have been replaced
- Tripped contactors or circuit breakers have been reset

7.4 Line Circuit Breaker

A line circuit breaker is mounted in the generator output box. If the load exceeds the circuit breaker current rating, the line circuit breaker will open, preventing the generator set from being overloaded. If the circuit breaker trips, locate the source of the overload or short circuit, and correct/eliminate the fault. Manually reset the breaker. Clear any fault messages and when safe to do so, reconnect the load to the generator.

7.5 Status Indicators - PowerCommand 2.3

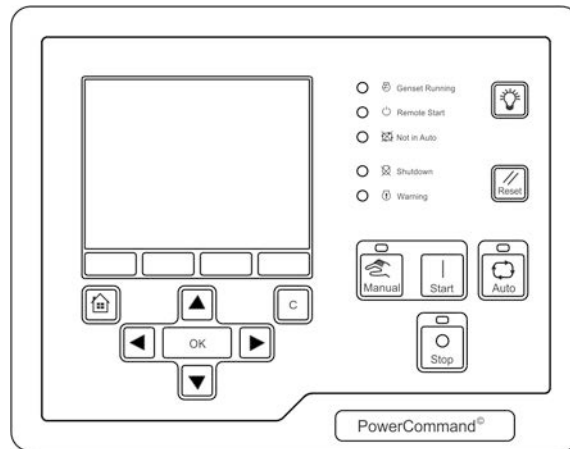

FIGURE 48. OPERATOR PANEL (HMI 320)

7.5.1 Not in Auto

This red lamp is lit when the control is NOT in Auto.

7.5.2 Remote Start

This green lamp indicates the control is receiving a **Remote Run** signal. The **Remote Run** signal has no effect unless the generator set is in Auto.

7.5.3 Warning

This amber lamp is lit whenever the control detects a Warning condition. This lamp is automatically shut off when the Warning condition no longer exists.

7.5.4 Shutdown Status

This red lamp is lit when the control detects a Shutdown condition. The generator set cannot be started when this lamp is on. After the condition has been corrected, the lamp can be reset by pressing the **Off** button.

NOTICE

When Battle Short mode is enabled and an overridden shutdown fault occurs, the Shutdown lamp lights, even though the generator set continues to run.

7.5.5 Generator Set Running Lamp

The green lamp is lit when the generator set is running at, or near, rated speed and voltage. This is not lit while the generator set is warming up or cooling down.

7.6 Fault/Status Codes - PowerCommand 2.3

7.6.1 Fault/Status Codes

⚠ WARNING***Electrical Generating Equipment***

Incorrect operation and maintenance can result in severe personal injury or death.

Make sure that only suitably trained and experienced service personnel perform electrical and/or mechanical service.

⚠ WARNING***Automated Machinery***

Accidental or remote starting of the generator set can cause severe personal injury or death.

Make sure that the generator set cannot be started accidentally or remotely before starting work on the generator.

The fault codes have been divided into five categories to help you determine what corrective action to take for safe operation of the generator set. Use the Fault Codes table to find the category (CTG) and fault description for all codes.

NOTICE

Gaps in the code numbers are for codes that do not apply to this generator set. Some of the codes listed are feature dependent and will not be displayed by this control.

7.6.2 Fault Messages

A Fault message is an indicator of a Warning or Shutdown condition. It includes the fault type (Warning or Shutdown), fault number, and a short description. It also includes where the fault occurred if the generator set control did not detect the fault and is simply reporting the fault.

Active and acknowledged faults may be viewed in the Faults menu.

7.6.3 Fault Acknowledgement

Shutdown faults must be acknowledged after the fault has been corrected. If in Auto or Manual mode, the control must be set to Stop mode (Off). Faults are cleared from the control panel display by pressing the **Reset** button.

Faults are re-announced if they are detected again after being acknowledged. See the Reset Button section.

NOTICE

Faults may also be acknowledged when in Auto mode and the Remote Start command is removed. Contact your authorized distributor for this option.

7.6.4 Category A Fault Codes

This category pertains to engine or alternator shutdown faults that require immediate repair by trained and experienced service personnel (generator set non-operational). The control prevents the generator set from being re-started if a shutdown fault has not been corrected.

7.6.5 Category B Fault Codes

This category consists of faults that can affect generator set performance or can cause engine, alternator, or connected equipment damage. Operate the generator set only when it is powering critical loads and cannot be shut down. These faults require repair by trained and experienced service personnel.

7.6.6 Category C Fault Codes

NOTICE

Continued operation may void the generator set warranty if damage occurs that relates to this type of fault condition.

This category consists of faults that do not affect generator set performance, but require repair by trained and experienced service personnel. These codes indicate a defective harness or wiring problem.

These codes can also indicate a defective engine sensor, leaving no engine protection. (Without this protection, engine damage can occur without detection).

7.6.7 Category D Fault Codes

This category consists of faults that are repairable by site personnel. Service will be required by trained and experienced service personnel if site personnel cannot resolve the problem.

7.6.8 Category E Fault Codes

This category indicates non-critical operational status of the generator set, external faults, or customer fault inputs. These faults require repair by trained and experienced service personnel.

7.6.9 Fault Codes - PowerCommand 2.3

TABLE 23. FAULT CODES

CTG	Code	Lamp	Displayed Message	Description
A	121	Shutdown	SPEED SIGNAL LOST	Indicates that no magnetic pickup pulses were sensed for a Loss of Speed delay. If a magnetic pickup is disabled, this fault is not activated.
B	135	Warning	OIL PRESS SENSOR OOR HIGH	Indicates the oil pressure sensor output is out of range (OOR), high.
C	141	Warning	OIL PRESS SENSOR OOR LOW	Indicates the oil pressure sensor output is out of range (OOR), low.
B	143**	Warning	PRE-LOW OIL PRESSURE	Indicates the engine oil pressure is approaching an unacceptable level.
C	144	Warning	COOLANT SENSOR OOR LOW	Indicates the coolant temperature sensor output is out of range (OOR), low.
C	145	Warning	COOLANT SENSOR OOR HIGH	Indicates the coolant temperature sensor output is out of range (OOR), high.
C	146**	Warning	PRE-HIGH COOLANT TEMP	Indicates that the engine is operating near cooling system capacity. Increase in load or higher ambient temperature may cause High Coolant Temp (code 151) shutdown.
D	151**	Shutdown	HIGH COOLANT TEMP	Indicates that the engine coolant temperature is above normal and has reached the Shutdown trip point.
C	153	Warning	INTAKE MANIFOLD TEMP OOR HIGH	Indicates that the intake manifold temperature sensor is out of range (OOR), high.
C	154	Warning	INTAKE MANIFOLD TEMP OOR LOW	Indicates that the intake manifold temperature sensor is out of range (OOR), low.
D	155	Shutdown	INTAKE MANIFOLD TEMP HIGH	Indicates that the intake manifold temperature sensor is above normal and has reached the shutdown trip point.
C	195	Warning	COOLANT LEVEL OOR HIGH	Indicates that a sensor on the radiator has detected that the coolant level is out of range (OOR), high.
C	196	Warning	COOLANT LEVEL OOR LOW	Indicates that a sensor on the radiator has detected that the coolant level is out of range (OOR), low.
D	197	Warning	COOLANT LEVEL LOW	Indicates that a sensor on the radiator has detected that the coolant level is below normal.
A	234**	Shutdown	OVERSPEED	Indicates that the engine has exceeded normal operating speed. The default thresholds are 1725 RPM (50 Hz) or 2075 RPM (60 Hz).
A	285	Shutdown	ECM PGN TIMEOUT	Datalink failure. PowerCommand® 2.3 control not responding to the engine control module.
A	286	Shutdown	ECM CONFIGURABLE ERROR	Indicates an engine control module configuration error – out of calibration.
D	359	Shutdown	FAIL TO START	The system has failed to start after a set number of crank attempts. This indicates a possible fuel system or air induction problem (engine cranks but fails to start).

CTG	Code	Lamp	Displayed Message	Description
A	415**	Shutdown	LOW OIL PRESSURE	Indicates the engine oil pressure has dropped below normal and has reached the shutdown trip point.
C	421^	Shutdown	OIL TEMP HIGH	Indicates the engine oil temperature is above normal and has reached the shutdown trip point. (I/O Module option).
B	425^	Shutdown	OIL TEMP OOR	Indicates the engine oil temperature output is out of range (OOR). High or low. (I/O Module option).
A	426	Shutdown	DATA LINK ERROR	Datalink failure. No communications between the PowerCommand® 2.3 control and the engine control module.
A	427**	Warning	CAN LINK LOST	Datalink fault. Indicates that important data was lost between the PowerCommand® 2.3 control and the engine control module.
D	441**	Warning	LOW BATTERY	Indicates battery voltage supply to the control is approaching a low level at which unpredictable operation can occur.
D	442**	Warning	HIGH BATTERY	Indicates battery voltage supply to the control is approaching a high level at which damage to the control can occur.
D	488^	Shutdown	INTAKE MANIFOLD TEMP HIGH	Indicates that the intake manifold temperature is above normal and has reached the shutdown trip point. (I/O Module option).
A	689	Shutdown	ENGINE SPEED ERRATIC	Indicates a fault condition in the engine crankshaft sensor circuit.
A	781	Shutdown	CAN LINK LOST	Datalink failure. No communications between the PowerCommand® 2.3 control and the engine control module.
D	1117	Warning	ECM POWER LOST	Indicates battery voltage supply to the engine control module was lost.
B	1123*	Shutdown	SHUTDOWN AFTER BS	A shutdown fault occurred while the Battle Short mode was enabled.
D	1131*	Warning	BATTLE SHORT ACTIVE	Indicates that the control is in Battle Short mode – used to bypass several fault shutdowns for generator set operation during emergencies.
C	1246	Warning	GENERIC ENGINE FAULT	Engine control fault code not recognized by the PowerCommand® 2.3 control.
E	1311	Configurable	Customer Fault Input 1	The nature of the fault is an optional customer selection.
E	1312	Configurable	Customer Fault Input 2	The nature of the fault is an optional customer selection.
E	1317	Configurable	Customer Fault Input 3	The nature of the fault is an optional customer selection.
E	1318	Configurable	Customer Fault Input 4	The nature of the fault is an optional generator set input.

CTG	Code	Lamp	Displayed Message	Description
B	1416*	Warning	FAIL TO SHUTDOWN	Indicates that a shutdown fault is active, but is being bypassed by Battle Short.
A	1417	Shutdown	FAILURE TO POWER DOWN	Indicates the control is powered up after attempting to go to sleep.
D	1433	Shutdown	LOCAL EMERGENCY STOP	Indicates a Local Emergency Stop has been activated.
D	1434	Shutdown	REMOTE EMERGENCY STOP	Indicates a Remote Emergency Stop has been activated.
D	1435**	Warning	LOW COOLANT TEMP	Indicates that the engine coolant temperature is below the adjusted setpoint. This may indicate that the coolant heater is not operating or is not circulating coolant.
D	1438	Shutdown	FAIL TO CRANK	The generator set has failed to sense rotation for two start attempts. This indicates a possible fault with the control, speed sensing, or the starting system.
D	1442**	Warning	WEAK BATTERY	Indicates that the generator set battery voltage is below battery thresholds during cranking.
A	1446**	Shutdown	HIGH AC VOLTAGE	Indicates that one or more measured AC output voltages have exceeded the threshold for longer than a specified time limit. The threshold and time limits are 130% of nominal for zero seconds or 110% of nominal for ten seconds.
A	1447**	Shutdown	LOW AC VOLTAGE	Indicates that the measured AC output voltage is below the threshold for longer than a specified time limit. The threshold and time limits are 85% of nominal for ten seconds.
A	1448**	Shutdown	UNDER FREQUENCY	Indicates that the alternator frequency is 6 Hz under the nominal frequency.
A	1449**	Shutdown	OVER FREQUENCY	Indicates that the alternator frequency is 6 Hz above the nominal frequency.
A	1469**	Shutdown	SPEED HZ MATCH	Indicates that measured engine speed and measured alternator AC output frequency do not agree.
B	1471**	Warning	HIGH AC CURRENT	Indicates that the alternator output current (one or more phases) has exceeded safe operating limits.
A	1472**	Shutdown	HIGH AC CURRENT	Indicates that the alternator output current (one or more phases) has exceeded the alternator's current rating.
C	1845	Warning	WATER IN FUEL OOR HIGH	Indicates the water in fuel sensor is out of range (OOR), high.
C	1846	Warning	WATER IN FUEL OOR LOW	Indicates the water in fuel sensor is out of range (OOR), low.
D	1852	Warning	WATER IN FUEL	Indicates that the water in fuel is above normal and has reached the warning trip point.
E	1853	Configurable	Annunciator Fault 2	The nature of the annunciator fault is an optional customer selection.

CTG	Code	Lamp	Displayed Message	Description
E	1854	Configurable	Annunciator Fault 3	The nature of the annunciator fault is an optional customer selection.
E	1855	Configurable	Annunciator Fault 1	The nature of the annunciator fault is an optional customer selection.
E	1944	Warning	ANNUNCIATOR OUTPUT CONFIGURATION ERROR	Indicates a mismatch in the configuration of one of the annunciator relay outputs.
D	1965 [^]	Warning	EXHAUST TEMPERATURE OOR	Indicates the exhaust temperature sensor is out of range (OOR), high or low. (Aux 101 I/O option).
B	1992	Warning	ENGINE OVERSPEED	Indicates that the engine has exceeded normal operating speed. The default thresholds are 1725 RPM (50 Hz) or 2075 RPM (60 Hz). (ECM fault code).
C	2224 [^]	Warning	FUEL LEVEL OOR	Indicates the fuel level sensor is out of range (OOR), high or low. (Aux 101 I/O option).
A	2335	Shutdown	EXCITATION FAULT	Indicates that a loss of voltage or frequency sensing from the generator has occurred.
C	2398 [^]	Warning	AMBIENT TEMPERATURE OOR	Indicates the ambient temperature sensor is out of range (OOR), high or low. (Aux 101 I/O option).
C	2542 [^]	Warning	VOLTAGE BIAS OOR	Indicates the voltage bias circuit output is out of range (OOR), high or low. (Aux 101 I/O option).
A	2545	Shutdown	KEYSWITCH RESET REQUIRED	Indicates a datalink failure. Communications are lost between the PowerCommand [®] 2.3 control and the engine control module.
E	2619 [^]	Diagnostic	AUX 101 ANALOG INPUT 1	The nature of the Base I/O Module event is an optional customer selection. (Aux 101 I/O Module option). Each event function can be programmed (using InPower service tool or access to the Setup menu), as follows: <ol style="list-style-type: none"> 1. Change display name using up to 32 characters 2. Select active low or high input.
E	2621 [^]	Diagnostic	AUX 101 ANALOG INPUT 2	See code 2619
E	2622 [^]	Diagnostic	AUX 101 ANALOG INPUT 3	See code 2619
E	2623 [^]	Diagnostic	AUX 101 ANALOG INPUT 4	See code 2619
E	2624 [^]	Diagnostic	AUX 101 ANALOG INPUT 5	See code 2619
E	2625 [^]	Diagnostic	AUX 101 ANALOG INPUT 6	See code 2619
E	2626 [^]	Diagnostic	AUX 101 ANALOG INPUT 7	See code 2619

CTG	Code	Lamp	Displayed Message	Description
E	2627^	Diagnostic	AUX 101 ANALOG INPUT 8	See code 2619
E	2628^	Diagnostic	AUX 102 DIGITAL INPUT 9	The nature of the Aux I/O Module event is an optional customer selection. (Aux 102 I/O Module option). Each event function can be programmed (using InPower service tool or access to the Setup menu), as follows: <ol style="list-style-type: none"> 1. Change display name using up to 32 characters 2. Select active low or high input.
E	2629^	Diagnostic	AUX 102 DIGITAL INPUT 10	See code 2628
E	2631^	Diagnostic	AUX 102 DIGITAL INPUT 11	See code 2628
E	2632^	Diagnostic	AUX 102 DIGITAL INPUT 12	See code 2628
A	2676	Shutdown	ALTERNATOR FREQUENCY CONFLICT	Indicates the measured alternator line frequency and measured alternator excitation frequency do not agree.
A	2677	Shutdown	FAIL TO STOP	The generator set continues to run after receiving a stop command from the controller.
B	2678**	Warning	CHARGER FAILURE	Indicates the battery charging alternator has not reached an acceptable voltage range within the selected time period (default is 120 seconds). This warning is also displayed if your alternator is a type that does not support the control's charging alternator logic functionality. If this occurs, this warning can be disabled if the Charging Alt. Enable setting is set to "No".
C	2693^	Warning	SPEED BIAS OOR	Indicates the speed bias circuit output is out of range (OOR), high or low. (Aux 101 I/O Module option).
C	2694^	Warning	ALTERNATOR RTD OOR	Indicates the alternator RTD sensor is out of range (OOR), high or low. (Aux 101 I/O Module option).
A	2696^	Shutdown	ALTERNATOR RTD TEMP HIGH	Indicates the alternator temperature is above normal and has reached the shutdown trip point. (I/O Module option).
C	2729^	Warning	I/O MODULE LOST	Indicates an intermittent datalink between the I/O module and the control board. (Aux 101 I/O Module option).
C	2731	Shutdown	I/O MODULE LOST	Indicates the datalink between the I/O module and the control board is lost. (Aux 101 I/O Module option).
A	2897	Shutdown	FACTORY BLOCK CORRUPT	Indicates a fatal software error occurred in the PowerCommand® 2.3 control.
A	2898	Warning	PERIODIC/ FAULT CORRUPT	Indicates that either the periodic data file or the fault history file has been corrupted. Remove and re-apply power to the control to clear the fault. (Periodic and/or fault history data will be lost after re-setting the control).
A	2899	Shutdown	USER BLOCK CORRUPT	Indicates a fatal software error occurred in the PowerCommand® 2.3 control.

CTG	Code	Lamp	Displayed Message	Description
A	2911	Shutdown	TRIM BLOCK CORRUPT	Indicates a fatal software error occurred in the PowerCommand® 2.3 control.
D	2964	Warning	INTAKE MANIFOLD TEMPERATURE HIGH	Indicates engine has begun to overheat (intake manifold temperature has risen to an unacceptable level). Increase in load or higher ambient temperature may cause Intake Manifold Temp High (code 155) shutdown.
A	2972**	Shutdown	FIELD OVERLOAD	Indicates that the Field Voltage has been above 70 V for eight seconds.

* For more information on these events, refer to the Battle Short Mode description in [Chapter 4 on page 37](#).

** Any values listed in the Description column for these faults are default values.

^ These faults are available only if your installation includes the optional I/O Module (Kit 541-1291)

7.6.10 Customer Input Faults - PowerCommand 2.3

Dependent on customer options specified, the customer input faults may indicate the following:

- Earth Fault
- Low Fuel
- High Fuel
- High Alternator Temperature

Depending on the number of customer options required, an adjacent display panel may be fitted where these faults will be displayed.

TABLE 24. TROUBLESHOOTING PROCEDURES FOR FAULT CODES

Fault Code	Lamp	Message	Corrective Action*
143	Warning	PRE-LOW OIL PRESSURE	Indicates engine oil pressure has dropped below the warning trip point. If the generator is powering critical loads and cannot be shut down, wait until the next shutdown period and then follow the code 415 procedure.
146	Warning	PRE-HIGH COOL TEMP	Indicates the engine is operating near cooling system capacity. Increase in load or higher ambient temperature may cause a High Coolant Temp (151) shutdown. Review code 151 correction list for other possible causes.

Fault Code	Lamp	Message	Corrective Action*
151	Shutdown	HIGH COOLANT TEMP	<p>Indicates the engine has overheated (coolant temperature has risen above the shutdown trip point). Allow the engine to cool down completely before proceeding with the following checks:</p> <ol style="list-style-type: none"> 1. Look for possible coolant leakage points and repair them if necessary. 2. Check the coolant level and replenish it if low. 3. Check for obstructions to cooling airflow and correct them as necessary. 4. Check the fan belt, and repair or tighten it if necessary. 5. Check the blower fan and circulation pumps on remote radiator installations. 6. Reset the control and restart after locating and correcting the problem.
155, 488	Shutdown	INTAKE MANIFOLD TEMP HIGH	<p>Indicates the engine has overheated (intake manifold temperature has risen above the shutdown trip point). Large load or high ambient temperature may be the cause. Review the code 151 correction list for other possible causes.</p>
197	Warning	COOLANT LEVEL LOW	<p>Indicates engine coolant level has fallen below the trip point. If the generator is powering critical loads and cannot be shut down, wait until the next shutdown period. If the engine can be stopped, allow the engine to cool down completely before proceeding:</p> <ol style="list-style-type: none"> 1. Look for coolant leakage points and repair if necessary. 2. Check the coolant level and replenish it if low. 3. Reset the control and restart after locating and correcting problem.
359	Shutdown	FAIL TO START	<p>Indicates a possible fuel system or air induction problem. (Engine cranks but fails to start.) Allow the engine to cool down completely before proceeding with the following checks:</p> <ol style="list-style-type: none"> 1. Check for an empty fuel tank, fuel leaks, or blocked fuel lines, and correct as required. 2. Check for a dirty fuel filter and replace it if necessary. 3. Check for a dirty or blocked air filter and replace it if necessary. 4. Reset the control and restart after correcting the problem.

Fault Code	Lamp	Message	Corrective Action*
415	Shutdown	LOW OIL PRESSURE	<p>Indicates engine oil pressure has dropped below the shutdown trip point. Allow the engine to cool down completely before proceeding with the following checks:</p> <ol style="list-style-type: none"> 1. Check the oil level, lines, and filters. 2. If the oil system is OK but the oil level is low, replenish it. 3. Reset the control and restart after locating and correcting the problem.
441	Warning	LOW BAT VOLTAGE	<p>Indicates battery voltage supply to the control is approaching a low level at which unpredictable operation will occur. If the engine can be stopped, allow the engine to cool down completely before proceeding:</p> <ol style="list-style-type: none"> 1. If there are poor battery cable connections, clean the battery cable terminals and tighten all connections. 2. Check the battery charge voltage float level if applicable (raise float level). 3. If there is a discharged or defective battery, check the battery charger fuse. Recharge or replace the battery.
442	Warning	HIGH BAT VOLTAGE	<p>Indicates battery voltage supply to the control is approaching a high level at which damage to the control can occur. If the engine can be stopped, allow the engine to cool down completely before proceeding:</p> <ol style="list-style-type: none"> 1. If there are poor battery cable connections, clean the battery cable terminals and tighten all connections. 2. Check the battery charge float level, if applicable (lower float level).
1117	Warning	ECM POWER LOST	<p>Indicates that "Keyswitch" to the ECM was NOT removed for 30 seconds before removing battery power to the ECM (removing battery cable). To reset:</p> <ol style="list-style-type: none"> 1. Press the Stop button, then press the Emergency Stop button and wait for 30 seconds. 2. Re-set the Emergency Stop and select an operating mode (manual or remote).
1131	Warning	BATTLE SHORT ACTIVE	<p>Indicates that the control is in Battle Short mode (used to bypass several fault shutdowns therefore allowing generator set operation during emergencies).</p>
1311, 1312, 1317, 1318	Configurable	CONFIGURABLE INPUT 1, 2, 3, 4	<p>The nature of the fault is an optional customer selection. Example inputs: Low Fuel Day Tank, Water In Fuel, Ground Fault, etc. Each of the fault functions can be programmed (using the InPower service tool or by accessing the Setup menu), as follows:</p> <ol style="list-style-type: none"> 1. Event, Warning, or Shutdown level if Function Select = Fault Input. 2. Change the display name using up to 32 characters.

Fault Code	Lamp	Message	Corrective Action*
1416	Warning	FAIL TO SHUTDOWN	The generator set continues to run after receiving a shutdown command from the controller. The Battle Short feature is enabled (this is used to bypass several critical fault shutdowns therefore allowing generator set operation during emergencies).
1433, 1434	Shutdown	E-STOP-LOCAL, E-STOP-REMOTE	Indicates a local or remote Emergency Stop. Emergency Stop shutdown status can be reset only at the local control panel. After locating and correcting problem, reset the local/remote Emergency Stop button as follows: <ol style="list-style-type: none"> 1. De-activate (disable) the Emergency Stop button. 2. Press the Stop button. 3. Select the desired operating mode (manual or remote).
1435	Warning	LOW COOLANT TEMP	Indicates engine coolant heater is not operating or is not circulating coolant. If the engine can be stopped, allow the engine to cool down completely before proceeding with the following checks: <ol style="list-style-type: none"> 1. The coolant heater is not connected to a power supply. Check for a blown fuse or disconnected heater cable, and correct it as required. 2. Look for possible coolant leaks and repair as required. Check for low coolant level and replenish, if required.
1438	Shutdown	FAIL TO CRANK	The generator set is not operating. This warning occurs when engine coolant temperature is 21 °C (70 °F) or lower. Indicates a possible fault with control, speed sensing, or starting system. See code 441 for corrective action. Note: In applications where the ambient temperature falls below 4 °C (40 °F), Low Coolant Temp may be indicated even though the coolant heaters are operating.
1442	Warning	WEAK BATTERY	Indicates that during cranking, the battery voltage is at, or below, the weak battery warning trip point for a time greater than, or equal to the weak battery set time. See code 441 for corrective action.
1448	Shutdown	UNDER FREQUENCY	Indicates that the generator set frequency has dropped below 90% of nominal for approximately ten seconds. Allow the engine to cool down completely before proceeding with the following checks: <ol style="list-style-type: none"> 1. Check the fuel supply. 2. Check the air intake supply. 3. Check the load and correct any overload.

Fault Code	Lamp	Message	Corrective Action*
1852	Warning	WATER IN FUEL	<p>Indicates that the water in the fuel is above normal and has reached the warning trip point. If the engine can be stopped, allow the engine to cool down completely before proceeding with the following checks:</p> <ol style="list-style-type: none"> 1. Check the fuel in the tank (local or remote). 2. Drain and re-fill the tank if necessary. Be aware of all Health and Safety, and environmental issues if draining the tank.
2964	Warning	HIGH INTAKE MANIFOLD TEMP	<p>Indicates the engine is operating near system capacity. Increase in load or high ambient temperature may cause a High Intake Manifold Temperature (code 155) shutdown. If the engine can be stopped, allow the engine to cool down completely before proceeding with the following check:</p> <ol style="list-style-type: none"> 1. Review the code 151 correction list for possible causes.
*If in doubt, call your authorized service technician.			

This page is intentionally blank.

8 Manufacturing Facilities

U.S. and CANADA	EMEA, CIS	EMEA, CIS
Cummins Inc. 1400 73rd Ave. NE Minneapolis, MN 55432 USA	Cummins Inc. Columbus Avenue Manston Park Manston, Ramsgate Kent CT12 5BF United Kingdom	Cummins Inc. Royal Oak Way South Daventry Northamptonshire NN11 8NU United Kingdom
Toll Free 1-800-CUMMINS™ (1-800-286-6467) Phone +1 763-574-5000 Fax +1 763-574-5298	Phone +44 1843 255000 Fax +44 1843 255902	Phone +44 1327 88-6453 Fax +44 1327 88-6125
BRAZIL	CHINA	INDIA
Rua Jati, 310, Cumbica Guarulhos, SP 07180-900 CNPJ: 43.2201.151/0001-10 Brazil	Cummins Inc. No.118 South Quanli Road , Wuhan Economic& Technological Development Zone , Hubei, P.R.China 430058	Cummins Inc. Plot No B-2, SEZ Industrial Area, Village-Nandal & Surwadi, Taluka- Phaltan Dist- Satara, Maharashtra 415523 India
Phone 0800 286 6467	Phone + 86 (27) 8421 4008 Fax + 86 (27) 8421 4804	Phone +91 021 66305514
LATIN AMERICA	MEXICO	ASIA PACIFIC
3350 Southwest 148th Ave. Suite 205 Miramar, FL 33027 USA	Eje 122 No. 200 Zona Industrial San Luis Potosi, S.L.P. 78395 Mexico	Cummins Sales and Service Singapore Pte Ltd 85 Tuas South Avenue 1 Singapore 637419
Phone +1 954 431 551 Fax +1 954 433 5797	Phone +52 444 870 6700 Fax +52 444 824 0082	Fax +65 6265 6909

8.1 How to Obtain Service

When a product requires servicing, contact the nearest Cummins service provider. To locate the distributor, go to www.cummins.com/support and select Sales and Service Locator. When contacting the service provider, always supply the complete model, specification, and serial number as shown on the nameplate.

8.1.1 Locating a Distributor

In the U.S. and Canada

To easily locate the nearest certified distributor/dealer for Cummins generator sets in your area, or for more information, contact us at 1-800-CUMMINS™ (1-800-286-6467) or visit www.cummins.com/support.

If unable to contact a distributor using the automated service, consult the Internet.

If unable to arrange a service or resolve an issue, contact the Service Manager at the nearest Cummins distributor for assistance.

When contacting the distributor, always supply the complete Model, Specification, and Serial Number as shown on the product nameplate.

Outside the U.S. and Canada

Refer to www.cummins.com/support and select Sales and Service Locator, or send an email to ask.powergen@cummins.com.

power.cummins.com

Copyright © 2019 Cummins Inc. All rights reserved.

Cummins, the "C" logo, PowerCommand, AmpSentry, and InPower are trademarks of Cummins Inc.

Other company, product, or service names may be trademarks or service marks of others.

Specifications are subject to change without notice.

