



## ***GLC Generator***

***(Gaseous Liquid Cooled)***

**GLC10, 15, 20, 25 35, 45, 55, 75, 105 and 130**

**Installation & Operating Manual**

Any trademarks used in this manual are the property of their respective owners.

**WARNING:**

**CALIFORNIA PROPOSITION 65 WARNING:**

**Engine exhaust from this product contains chemicals known to the state of California to cause cancer, birth defects and other reproductive harm.**

**WARNING:**

**CALIFORNIA PROPOSITION 65 WARNING:**

**Battery posts, terminals and related accessories are known to the state of California to cause cancer, birth defects and other reproductive harm.**

# Table of Contents

---

## Section 1

### Product Safety Information

Safety Notice .....	1-1
Responsibility .....	1-1
IMPORTANT SAFETY INSTRUCTIONS .....	1-2
Caution Statements .....	1-6

## Section 2

### General Information

Limited Warranty .....	2-1
Installation Guidelines .....	2-2
Site Planning .....	2-2
Room Size .....	2-2
Room Location .....	2-3
Utility Power .....	2-4
Foundation Design .....	2-4
Exhaust System .....	2-6
Level Of Attenuation .....	2-6
Multi-Engine Installations .....	2-7
Exhaust Manifold .....	2-7
Exhaust Gas Restriction .....	2-7
Exhaust Piping .....	2-8
Rain Protection .....	2-8
Transfer Switch .....	2-9
Battery Starting System .....	2-10
Battery Location .....	2-10
Battery Size .....	2-10
Battery Charger .....	2-10
Battery Cables .....	2-11
Formulas .....	2-12

## Section 3

### Receiving & Installation

Receiving & Inspection .....	3-1
Lifting the Genset .....	3-1
Physical Location .....	3-1
Secure the Genset .....	3-2
Engine Cooling .....	3-2
Hot Exhaust Gasses .....	3-6
Installation .....	3-7
Fuel Connections .....	3-7
Electrical Connections .....	3-10
Single Phase Power Connections .....	3-11
Battery Connections .....	3-14
Recommended Engine Coolant .....	3-15
Recommended Engine Oil and Battery Type .....	3-15
Post Installation Checks .....	3-15

---

<b>Section 4</b>	
<b>Operation</b>	
Digital Engine Controller Description .....	4-1
Alarms .....	4-4
Inputs and Outputs .....	4-5
Analog Inputs .....	4-6
Set points .....	4-6
<b>Section 5</b>	
<b>Troubleshooting and Maintenance</b> .....	5-1
Maintenance .....	5-1
Problems and Solutions .....	5-2
<b>Appendix A</b>	
<b>Options &amp; Accessories</b> .....	A-1
Battery Charger .....	A-1
Battery Heaters .....	A-2
Engine Block Heater .....	A-2
Silencers .....	A-3
Flexible Fuel Lines .....	A-4
E-Stop .....	A-4
Remote Annunciators .....	A-5
Radiator Duct Flange .....	A-6
<b>Appendix B</b>	
<b>Series GLC Information &amp; Wiring Diagrams</b> .....	B-1
GLC Circuit Breaker & Wire Size .....	B-1
Wiring Diagrams .....	B-1

# Section 1

## Product Safety Information

---

### **Safety Notice**

**Be sure that you are completely familiar with the safe operation of this equipment. This equipment may be connected to other machines that have rotating parts or parts that are controlled by this equipment. Improper use can cause serious or fatal injury. Always disconnect all electrical loads before starting the generator.**

Installation and repair procedures require specialized skills with electrical generating equipment and liquid cooled engine systems. Any person that installs or repairs this generator must have these specialized skills to ensure that this generating unit is safe to operate. Contact Baldor service department for repairs or any questions you may have about the safe installation and operation of this system.

The precaution statements are general guidelines for the safe use and operation of this generator. It is not practical to list all unsafe conditions. Therefore, if you use a procedure that is not recommended in this manual you must determine if it is safe for the operator and all personnel in the proximity to the generator and connected loads. If there is any question of the safety of a procedure please contact Baldor before starting the generator.

This equipment contains high voltages. Electrical shock can cause serious or fatal injury. Only qualified personnel should attempt the start-up procedure or troubleshoot this equipment.

This equipment may be connected to other machines that have rotating parts or parts that are driven by this equipment. Improper use can cause serious or fatal injury. Only qualified personnel should attempt the start-up procedure or troubleshoot this equipment.

- System documentation must be available to anyone that operates this equipment at all times.
- Keep non-qualified personnel at a safe distance from this equipment.
- Only qualified personnel familiar with the safe installation, operation and maintenance of this device should attempt start-up or operating procedures.
- Always stop engine before making or removing any connections.
- Always stop engine and allow it to cool before refueling.

### **Responsibility**

When your generator is delivered, it becomes the responsibility of the owner/operator of the generator set to prevent unsafe conditions and operation of the equipment. Some responsibilities include (but are not limited to) the following:

1. It is the responsibility of the owner/operator of this generator to ensure that this equipment is correctly and safely installed.
2. It is the responsibility of the owner/operator of this generator to ensure that this equipment, when installed fully complies with all federal, state and local codes.
3. It is the responsibility of the owner/operator of this generator to ensure that any person operating this equipment has been properly trained.
4. It is the responsibility of the owner/operator of this generator to ensure that any person operating this equipment has access to all manuals and information required for the safe use and operation of this equipment.
5. It is the responsibility of the owner/operator of this generator to ensure that it is properly maintained and safety inspected at regular scheduled intervals.
6. It is the responsibility of the owner/operator of this generator to ensure that any person who has not been trained on the safe use of this equipment does not have access to this equipment.

### **Read This Manual Thoroughly**

If you do not understand any concept, any procedure, any safety warning statement, any safety caution statement or any portion of this manual, contact Baldor or your nearest authorized Baldor representative. We are happy to make sure you understand the information in this manual so that you can safely enjoy the full use of this generator.

---

## Symbols



This symbol is shown throughout the manual to indicate a connection to ground reference point.



Indicates a potentially hazardous situation which, if not avoided, could result in injury or death.



Indicates a potentially hazardous situation which, if not avoided, could result in injury or death.

## Precaution Statements Used In This Manual

There are three classifications of precautionary statements used in this manual. The most critical is a **WARNING** statement, then the **Caution** statement and the least critical is the Note statement. The usage of each statement is as follows:

**WARNING:** Indicates a potentially hazardous situation which, if not avoided, could result in injury or death.

**Caution:** Indicates a potentially hazardous situation which, if not avoided, could result in damage to property.

**Note:** Additional information that is not critical to the installation or operation.

## IMPORTANT SAFETY INSTRUCTIONS

**SAVE THESE INSTRUCTIONS** – This manual contains important instructions for the generator that should be followed during installation, operation and maintenance of the generator and battery (batteries). For ease of reading, the Warning statements are divided into four categories: Operation, Burn, Installation, and Maintenance.

### Operation

**WARNING:** Never operate this generator in a manner other than as described in this manual. Operation in any manner not described in this manual should be considered unsafe and should not be attempted. Never start the engine unless you have first verified that the installation and operation of the generator are as described in this manual.

**WARNING:** Be sure that you are completely familiar with the safe operation of this equipment. This equipment may be connected to other machines that have rotating parts or parts that are controlled by this equipment. Improper use can cause serious or fatal injury.

**WARNING:** Exhaust fumes/gases are extremely dangerous and can cause severe illness or death. Never breath exhaust fumes produced by a running engine. Only run the engine outdoors where ventilation is plentiful. Exhaust gases contain carbon monoxide, a colorless, odorless and extremely dangerous gas that can cause unconsciousness or death. Symptoms of carbon monoxide poisoning include: dizziness, nausea, headaches, sleepiness, vomiting or incoherence. If you or anyone else experiences these symptoms, get out into fresh air immediately. Stop the engine and do not restart the engine until it has been inspected and if necessary repaired or reinstalled in a well ventilated area.

**WARNING:** Hot exhaust gasses must never be directed toward anything that may catch fire or explode.

**WARNING:** This generator must not be used on or near any forest covered, brush covered, or grass covered land unless the engine's exhaust system is equipped with a spark arrestor. The spark arrestor must be maintained in effective working order by the operator.

**WARNING:** Some parts of this generator rotate during operation. Rotating parts can present extreme danger if clothing or body extremities are caught by the rotating part and can cause serious or fatal injury. Never touch a part of the generator until the engine has been stopped and all rotating parts are completely stopped. Also, disconnect the spark plug wires and battery connection to prevent accidental engine rotation during servicing.

**WARNING:** Never move a generator set that is running. Loads should be connected and position secure before starting the engine. Hazards are caused by moving a generator set that is running.

Continued on next page.

---

**Operation Warning Statements** Continued

- WARNING:** Never connect or disconnect loads during operation. Always connect load circuits before starting the engine and use external branch disconnects etc. to switch loads On/Off.
- WARNING:** Be sure that you understand how to stop the engine quickly in case of an emergency situation. Become familiar with the controls and safety systems provided with this generator set.
- WARNING:** Always wear safety glasses with side shields and hearing protection when working near the generator.
- WARNING:** Improper operation may cause violent motion of connected equipment. Be certain that unexpected movement will not cause injury to personnel or damage to equipment.
- WARNING:** Never operate the generator set indoors or in a poorly ventilated area such as a tunnel or cave. Exhaust fumes are extremely dangerous to all personnel that are in or in contact with that area.
- WARNING:** Never permit anyone to operate the generator without proper instructions. Be sure to keep a copy of this manual with the generator so that all users can be properly informed of its safe operation.
- WARNING:** Never allow children or pets to be in the area where the generator is running. The generator and the equipment being powered by the generator may cause injury or death.
- WARNING:** Never operate the generator unless all guards, covers, shields and other safety items are properly installed.
- WARNING:** Do not put hands, feet, tools clothing or other objects near rotating parts such as drive shaft, pulley, belt etc. Rotating parts cause extremely dangerous situations because they can catch loose clothing or extremities and cause serious or fatal injury.
- WARNING:** When operating this generator remain alert at all times. Never operate machinery when physically or mentally fatigued, or while under the influence of alcohol, drugs or medication.
- WARNING:** Never operate the engine when the air cleaner is removed. An engine backfire can cause serious burns.
- WARNING:** Never “jump start” a generator to start the engine. If the battery charge is insufficient to start the engine, charge or replace the battery and try to restart. Jump starting a battery can cause the battery to explode and cause severe injury or death to anyone in the area.
- WARNING:** High voltage is present whenever engine is running. Electrical shock can cause serious or fatal injury. Never operate electrical equipment while standing in water, on wet ground or with wet hands, feet or shoes or while barefoot.
- WARNING:** High voltage is present whenever the engine is running. Electrical shock can cause serious or fatal injury. Always stop engine before connecting or disconnecting power cords or external devices.
- WARNING:** Do not smoke near generator during operation or when close to fuel source. LPG and natural gas fuels are flammable and can cause fire, explosions, injury or death.
- WARNING:** Keep generator at least three feet away from buildings and other structures.
- WARNING:** Keep generator away from flammable or hazardous materials (trash, rags, lubricants, explosives, paints etc.) and grass or leaf build up.
- WARNING:** Keep a fire extinguisher near the generator while generator is in use. An extinguisher rated “ABC” by the National Fire Protection Association is appropriate.

**Burn**

- WARNING:** Parts of this generator are extremely hot during and after operation. To prevent severe burns, do not touch any part of the generator until you have first determined if the part is hot. Wear protective clothing and after use allow sufficient time for parts to cool before touching any part of the generator.
- WARNING:** Do not touch the hot exhaust parts or the high voltage spark plug or coil terminals of the engine. Although spark plug voltages are not normally lethal, a sudden involuntary jerk of the hand or body part caused by contact with high voltage or a hot surface can result in injury to yourself or others.
- WARNING:** Engine coolant is under pressure and is near the boiling point of water when engine is hot. Do not open the coolant system until the engine has completely cooled. Hot coolant can cause severe burns and other injuries. When engine is cool, coolant level can be checked.

Continued on next page.

---

**Warning Statements** Continued

**Installation**

- WARNING:** Installation and servicing of batteries is to be performed or supervised by personnel knowledgeable of batteries and the required precautions. Keep unauthorized personnel away from batteries.
- WARNING:** Disconnect the battery's ground terminal before working in the vicinity of the battery or battery wires. Contact with the battery can result in electrical shock when a tool accidentally touches the positive battery terminal or wire. The risk of such shock is reduced when the ground lead is removed during installation and maintenance.
- WARNING:** An open bottom stationary engine generator set must be installed over noncombustible materials and shall be located such that it prevents combustible materials from accumulating under the generator set.
- WARNING:** Installation and repair procedures requires specialized skills with electrical generating equipment and small engine systems. Any person that installs or performs repairs must have these specialized skills to ensure that the generator set is safe to operate. Contact Baldor for installation or repairs.
- WARNING:** Be sure all wiring complies with the National Electrical Code (NEC) and all regional and local codes or CE Compliance. Improper wiring may cause a hazardous condition and exposure to electrical hazards can cause serious injury or death.
- WARNING:** Be sure the system is properly grounded before applying power. Do not apply AC power before you ensure that grounds are connected. Electrical shock can cause serious or fatal injury. NEC requires that the frame and exposed conductive surfaces (metal parts) be connected to an approved earth ground. Local codes may also require proper grounding of generator systems.
- WARNING:** Place protective covers over all rotating parts such as drive shaft, pulley, belt etc. Rotating parts cause extremely dangerous situations because they can catch loose clothing or extremities and cause serious or fatal injury.
- WARNING:** Unauthorized modification of a generator set may make the unit unsafe for operation or may impair the operation of the unit. Never start a generator set that has been modified or tampered with. Be sure that all covers and guards are properly installed and that the unit is safe before starting the engine. If you are unsure, contact Baldor before starting the engine.
- WARNING:** When moving the generator, use reasonable caution. Be careful where you place fingers and toes to prevent injury "Pinch Points". Never try to lift a generator without a hoist or lift means because they are heavy and bodily injury may result.
- Warning:** Never connect this generator to the electrical system of any building unless a licensed electrician has installed an approved transfer switch. The national electrical code (NEC) requires that connection of a generator to any electrical circuit normally powered by means of an electric utility must be connected by means of approved transfer switch equipment to isolate the electrical circuit from the utility distribution system when the generator is operating. Failure to isolate the electrical circuits by such means may result in injury or death to utility power workers due to backfeed of electrical energy onto the utility lines.
- WARNING:** Circuit overload protection must be provided in accordance with the National Electrical Code and local regulations.
- WARNING:** Check Ground Fault Circuit Interrupt (GFCI) receptacles monthly by using the "Test" and "Reset" buttons.
- WARNING:** Only a professional experienced technician should install a fuel supply system. LPG and natural gas fuels are flammable and can cause fire, explosions, injury or death. Fuel supply lines should be kept away from sharp objects to prevent rupture. Comply with all NFPA regulations and local codes for shut-off valves, regulators, fuel line type, connectors etc.
- WARNING:** Have electrical circuits and wiring installed and checked by licensed electrician or qualified technician. Electrical shock can cause serious or fatal injury.
- WARNING:** Incorrect installation of this generator set could result in property damage, injury or death. Connection of the generator to its fuel source must be done by a qualified professional technician or contractor.
- WARNING:** An open bottom stationary engine generator set must be installed over noncombustible materials and shall be located such that it prevents combustible materials from accumulating under the generator set.

Continued on next page.



---

**Warning Statements** Continued

**Battery Safety**

**WARNING: Installation and servicing of batteries is to be performed or supervised by personnel knowledgeable of batteries and the required precautions. Keep unauthorized personnel away from batteries.**

**WARNING: Do not dispose of battery or batteries in a fire. The battery is capable of exploding. If the battery explodes, electrolyte solution will be released in all directions. Battery electrolyte solution is caustic and can cause severe burns and blindness. If electrolyte contacts skin or eyes, immediately flush the area with water and seek medical attention quickly.**

**WARNING: Do not mutilate the battery . The battery contains electrolyte solution which is caustic and can cause severe burns and blindness. If electrolyte contacts skin or eyes, immediately flush the area with water and seek medical attention quickly.**

**WARNING: A battery presents a risk of electrical shock hazard and high short circuit current. The following precautions are to be followed when working on batteries:**

1. Remove watches, rings, necklaces and all other metal objects.
2. Use tools with insulated handles.

**WARNING: The battery electrolyte is a dilute sulfuric acid that is harmful to the skin and eyes. It is electrically conductive and corrosive. The following precautions are to be followed when working on batteries:**

1. Wear full eye protection (safety glasses or goggles) and protective clothing.
2. Where electrolyte contacts the skin, flush the area immediately with water and wash it off using soap and water.
3. Where electrolyte contacts the eyes, immediately flush the eye thoroughly with water and seek medical attention quickly.
4. Spilled electrolyte is to be washed down with an acid neutralizing agent. A common practice is to use a solution of one pound (500 grams) bicarbonate of soda to one gallon (four liters) of water. The bicarbonate solution is to be added until evidence of reaction (foaming) has ceased. The resulting liquid is to be flushed with water and the area dried.

**WARNING: A battery presents a risk of fire because they generate hydrogen gas. Hydrogen gas is extremely explosive. Never jump start a battery, smoke in the area around the battery or cause any spark to occur in the area around the battery. The following precautions are to be followed when working on batteries:**

1. Do not smoke when near batteries.
2. Do not cause flame or spark in battery area.
3. Discharge static electricity from body before touching batteries by first touching a grounded metal surface.

Continued on next page.

---

**Warning Statements** Continued

**Maintenance**

- WARNING:** Before cleaning, inspecting, repairing or performing any maintenance to the generator set, always be sure the engine has stopped and that all rotating parts have also stopped. After stopping, certain components are still extremely hot so be careful not to get burned. Before servicing the generator set, be sure to disconnect the spark plug wires and the battery terminals to prevent accidental engine rotation or starting.
- WARNING:** Engine coolant is under pressure and is near the boiling point of water when engine is hot. Do not open the coolant system until the engine has completely cooled. Hot coolant can cause severe burns and other injuries. When engine is cool, coolant level can be checked.
- WARNING:** Before servicing the generator set, be sure to disconnect the spark plug wires and the battery terminals to prevent accidental engine rotation or starting.
- WARNING:** Inspect all wiring frequently and replace any damaged, broken or frayed wiring or wires with damaged insulation immediately. Electrical shock can cause serious or fatal injury.
- WARNING:** Disconnect all electrical wires and load devices from generator power outlets before servicing the generator. Electrical shock can cause serious or fatal injury. Always treat electrical circuits as if they are energized.
- WARNING:** Check all fuel supply piping, and their connections monthly for fuel leaks. LPG and natural gas fuels are flammable and can cause fire, explosions, injury or death. If a leak is found, replace only with approved pipe or components.

**Caution Statements**

- Caution:** Avoid installing the generator set beside heat generating equipment, or directly below water or steam pipes or in the vicinity of corrosive substances or vapors, metal particles and dust. Heat can cause engine problems to develop and unwanted substances can cause rust or generator failure over time.
- Caution:** Do not apply high voltage to windings (do not start the generator) in a moisture-saturated condition. Moisture can cause insulation breakdown, making it necessary to return the generator for repair.
- Caution:** Use only original equipment or authorized replacement parts. Using the correct parts will assure continued safe operation as designed.
- Caution:** Do not support the generator from the top of the frame or enclosure.
- Caution:** Do not tamper with or change the engine speed. Engine speed is factory set to produce the correct voltage and output frequency.
- Caution:** Never operate the engine without a muffler. The engine is designed to have the correct exhaust components installed and operating without these components can present a fire hazard, cause excessive exhaust gases and cause damage to engine. Inspect muffler periodically and replace if necessary.
- Caution:** The Programmable Output Contacts selection must agree with the external control wiring prior to energizing the controller. Failure to do so may cause severe equipment damage.

## Section 2 General Information

Thank you for purchasing your Baldor Generator Set. This manual contains information you need to safely and efficiently install and operate your generator set. During the preparation of this manual every effort was made to ensure the accuracy of its contents. This manual describes only very basic engine information. A separate owner's manual for the engine is supplied with this unit for your use. Please refer to the engine manual for information relative to engine operation, maintenance, recommendations and additional safety warnings.

Copyright Baldor © 2009. All rights reserved.

This manual is copyrighted and all rights are reserved. This document may not, in whole or in part, be copied or reproduced in any form without the prior written consent of Baldor Electric Company, Inc.

Baldor Generators have earned the reputation of being high quality and dependable. We take pride in this fact and continue to keep our quality standards high on our list of priorities. We are also constantly researching new technological ideas to determine if they could be used to make our generator sets even better.

Baldor makes no representations or warranties with respect to the contents hereof and specifically disclaims any implied warranties of fitness for any particular purpose. The information in this document is subject to change without notice. Baldor assumes no responsibility for any errors that may appear in this document.

### **Limited Warranty**

Baldor will replace or repair free of charge any part or parts of the generator of their manufacture that are defective in workmanship and materials for a period of time as set forth in the Warranty Period chart below. All Baldor products requiring warranty service shall be transported or shipped freight pre-paid to a Baldor Generator repair facility. Notification of the defect or problem, a description of the manner in which the Baldor generator is used, and the name, address and telephone number of the customer requiring warranty service must be included. Baldor is not responsible for removal and shipment of the Baldor product to the service center or for the reinstallation of the Baldor product upon its return to the customer, or any incidental or consequential damages resulting from the defect, removal, reinstallation, shipment or otherwise. Problems with Baldor products can be due to improper maintenance, faulty installation, non-Baldor additions or modifications, or other problems not due to defects in Baldor workmanship or materials. If a Baldor Generator repair facility determines that the problem with a Baldor product is not due to defects in Baldor workmanship or materials, then the customer will be responsible for the cost of any necessary repairs. Genset engines are covered under the engine manufacturers warranty. Proper engine maintenance is required. Any request for engine warranty or repair should be made directly with the engine manufacturers warranty center. See engine manufacturers data for applicable engine warranty periods and location of repair centers. This Limited Warranty and Service Policy represents Baldor's sole and exclusive warranty obligation with respect to Baldor products. Baldor's liability to a customer or any other person shall not exceed Baldor's sales price of the applicable Baldor product. **BALDOR DISCLAIMS ALL OTHER EXPRESSED AND IMPLIED WARRANTIES INCLUDING THE IMPLIED WARRANTIES OF FITNESS FOR A PARTICULAR PURPOSE AND MERCHANTABILITY.**

#### **Warranty Period**

<b>Generator Series</b>	<b>Labor*</b>	<b>Parts</b>
Portable Products (Premier, Powerchief, DG Series)	1 Year	3 Years
Towable Products (TS)	1 Year or 3,000 Hours	3 Years or 3,000 Hours
POW'R LITE Light Towers	1 Year or 3,000 Hours	3 Years or 3,000 Hours Light Fixture, Lamps and Ballasts are excluded from any warranty coverage
3600 RPM Standby Systems (Some AE Models)	1 Year or 1,000 Hours	3 Years or 1,000 Hours
1800 RPM Standby Systems (Some AE Models, DLC, GLC)	1 Year or 3,000 Hours	3 Years or 3,000 Hours
Industrial Standby Systems	1 Year or 1,000 Hours	2 Years or 1,000 Hours
Industrial Prime Power Systems	1 Year or 1,000 Hours	1 Year or 1,000 Hours
International	1 Year or 1,000 Hours	1 Year or 1,000 Hours

\*For products covered under labor coverage, travel expenses will be allowed up to 7 hours straight labor or 300 miles, whichever occurs first, and only applies to permanently wired and mounted products (AE, DLC, GLC, IDLC).

You must save the purchase receipt. Proof of purchase, date, serial number and model number will be required for all portable and Towable products to qualify for any warranty consideration.

A start-up inspection form/warranty registration must be completed in its entirety and submitted to Baldor Generators within 30 days of start-up to qualify for any warranty consideration, excluding: Portables, Towables and Light Towers.

---

**Important**

Be sure you are completely familiar with all Safety Instructions detailed in Section 1 of this manual. Do not proceed if you are unsure of any detail. Contact your Baldor Distributor, they are experienced and are happy to assist you and to answer your questions.

**Installation Guidelines**

The procedures presented in this manual are suggestions and it is the responsibility of the Owner/Operator to arrange for these procedures to be performed by licensed contractors according to all applicable codes including local codes for your Municipality/City/County and State. In addition to these suggestions, before installing your generator you should obtain the most up to date copies of the following documents from the National Electrical Code and other authorities:

- National Electric Code, Articles 230, 250, 445, 517, 700.
- National Fire Protection Association
  - No. 30 – Storage, Handling and Use of Flammable Liquids.
  - No. 37 – Stationary Combustion Engines and Gas Turbines.
  - No. 99 – Essential Electrical Systems for Health Care Facilities.
  - No. 101 – Life Safety Code No. Systems.
  - No. 110 – 1985 Emergency and Standby Power Systems.
- NEMA MG1
- Local Codes applicable to Genset Installation. See your local building inspector.

NFPA (National Fire Protection Association) (617) 770-3000 (includes NEC)  
1 Batterymarch Park, Quincy, MA 02169-7471 USA

NEMA (National Electrical Manufacturers Association) (703) 841-3200  
1300 N. 17th Street, Suite 1847, Rosslyn, VA, 22209 USA

**Site Planning****Room Size**

Open frame generators must be protected from the environment while having good ventilation and cooling. Here are some considerations for planning a generator room or enclosure:

- Never use the Genset room for storage as well.
- The room must be large enough to contain the genset and all the accessories, such as batteries and their charging system, transfer switch and other controls, and elements of the cooling and fuel systems.
- A minimum of 3 feet (preferably 4 feet), must be allowed on the two sides of the engine for service access.
- On the generator end of the engine, allow a space equal to the length of the generator (generator length only, not the entire genset).
- At the front of the engine, 4 feet of clearance is preferable. Allow clearance between hot parts of the system (exhaust) and structural members of the building.
- Certain safety and building codes may require the genset room not to be used to house any other mechanical or electrical equipment.

---

**Room Location** Often a separate building located on the site away from the main building is the most simple and cost effective. Major considerations when housing the genset in a separate building are:

- Maintain the building at a satisfactory temperature year round (to meet applicable codes).
- Assure the genset is not located so far from the emergency loads that reliability is compromised.
- The floor's load carrying capacity must be checked and must exceed the weight of the genset and its associated equipment.
- **Engine Cooling System**  
A genset with an engine mounted radiator is the least costly to install; however, the room must be located in a place where sufficient radiator cooling air can be brought into and exhausted from the room.
- **Exhaust System**  
The exhaust system must minimize exhaust restriction. The exhaust system should be as short and have as few bends as possible.
- **Room Air**  
If the genset is cooled with an engine mounted radiator, and sufficient air is brought into and exhausted from the room to satisfy the radiator cooling requirements and the combustion air requirements, the room will not overheat when the genset is running. If a remote mounted radiator or a heat exchanger is used, and adequate air is circulated through the room to keep it at a reasonable temperature, there will be adequate air for combustion.
- **Controls and Transfer Switch**  
Locate the control switch gear as close to the emergency loads and the genset as practical. This will minimize the chances that a failure of the power line to the emergency load will go undetected. In locating the switchgear, accessibility for service and maintenance must be considered.
- **Genset Noise**  
Internal combustion engines produce noise, so the room should be located away from occupied buildings. In addition the genset room can be treated to reduce noise transmission. In locating the genset room, both engine, fan and exhaust noise must be considered.  
If noise within the genset room, or noise transmitted to the surrounding parts of the building are a concern, then the room must be made large enough to allow for installation of noise attenuating walls and noise absorbing walls.  
Light weight concrete blocks filled with sand or special "sound block" concrete blocks are commonly used. Noise attenuating, tight fitting windows and doors also help reduce noise transmission to the rest of the building.  
A double-walled room should be considered. Vibration isolators under the genset rails will also reduce the transmission of noise through the floor.
- **Code Requirements**  
Building and safety codes deal with engine location. These requirements are concerned with fire rated walls, a location that minimizes the possibility of damage to the genset and interruption of the emergency system due to storms, floods, fire, vandalism, etc.  
Codes often deal with the need to maintain certain temperatures in the genset room and with fuel system location. The most important codes in the USA are the National Fire Protection Association Code Numbers 99 and 110, but local codes must also be observed.

**Utility Power** During periods when the generator is not running, utility power must be provided to power critical components. Battery chargers, block heaters, space heaters and other devices must have power to maintain the generator set components and allow fast easy starting.

### Foundation Design

**WARNING:** An open bottom stationary engine Generator Set must be installed over noncombustible materials and shall be located such that it prevents combustible materials from accumulating under the Generator Set.

#### Foundation Checklist

- Evaluate if a separate, isolated foundation is required for the application.
  - Observe local codes on soil bearing capacity freezing and thawing.
  - Design the separate foundation for the Genset and specify the appropriate concrete mix.
  - Determine if the application requires vibration isolators and if so, order as a factory option.
- The foundation must be strong enough to support the weight of the Genset and its associated equipment, must prevent any deflection of the Genset base and absorb vibration produced by the rotating and reciprocating masses.

#### Setting The Genset On An Existing Concrete Floor Slab

- If an existing floor is used, the floor slab must be strong enough to carry 1.50 times the Genset wet weight (including coolant and oil) to accommodate dynamic loads.
- The actual mounting arrangement (ie., surface area in contact with the floor) will determine the compressive strength required.
- The Genset should be securely fastened to the floor slab with expansion anchors that fit the mounting holes shown on the Genset installation diagram.
- For installations not expected to be permanent, elastomer pad with non-slip surface placed between the base and the floor will also prevent movement.
- Any floor/slab surface should be as flat as possible to prevent sub-base deflection.

#### Vibration Isolators

- Vibration isolators are commonly used to mount the Genset to a concrete pad, Figure 2-1. The purpose of vibration isolators is to reduce the noise and vibration which would be transmitted from the Genset to the foundation or supporting structure.
- A simple and effective method of mounting and applying pad type isolators is to place non-skidding type isolation pads directly between the sub-base and floor. The number of pads required is determined by the rating of the pads and the Gensets weight.

**Figure 2-1 Typical Installation J-Bolt or Spring Type Isolator**

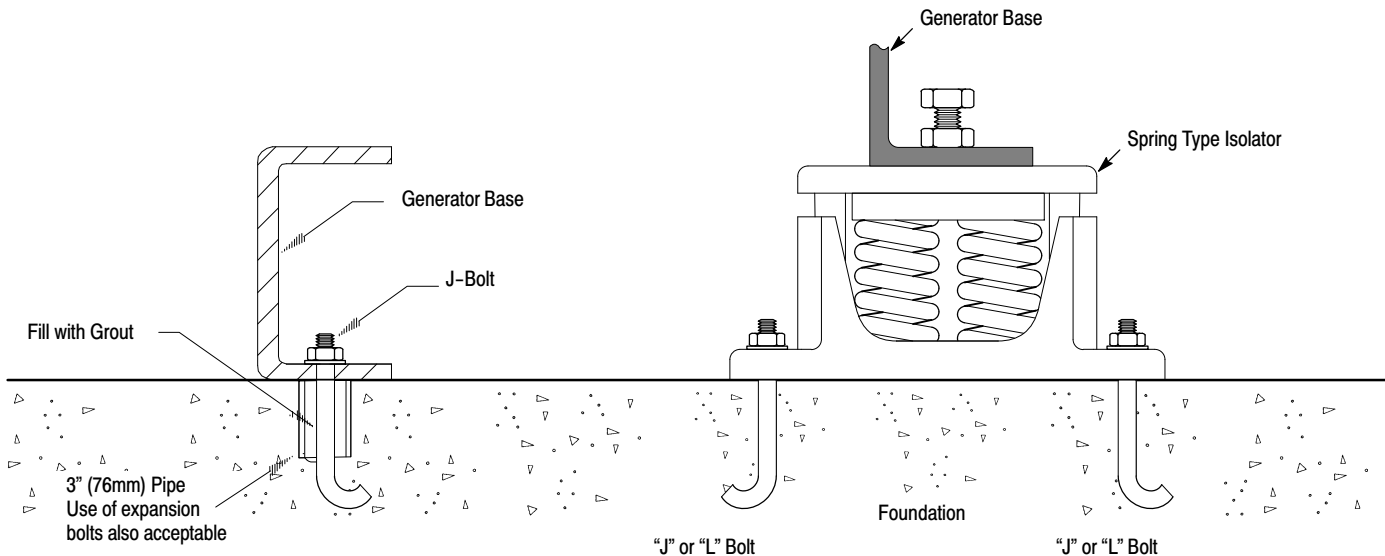

- Steel spring isolators are a very effective and commonly used. Steel spring isolators are typically 95–98% efficient (reduces the transmitted vibration 95–98%) while a pad type can be 75–88% efficient. Spring isolators also level the Genset sub-base in the event the foundation pad is not perfectly level. The base should be mounted to the foundation pad as shown in Figure 2-1 or as recommended by the isolator manufacturer.

A common practice is to pour a concrete pad directly on top of the floor slab and to mount the Genset on this pad. The purpose of the pad is for cleaning around the Genset and to provide a more level base. When using this method, floor strength must support the pad and the Genset. The pad should be at least 6in (150mm) thick and extend beyond the Genset in all directions 12in (300mm).

### Weight of the Genset

The dry weight of the entire Genset is shown on the Generator Set Specification Sheet. The wet weight includes the fluids (coolant and oil).

### Designing an Isolated Foundation

If the Genset cannot be mounted directly on a floor slab, or if it is desirable to isolate it from the floor slab, then a separate foundation slab must be designed.

A massive concrete foundation is not required. Outside dimensions of the foundation should exceed the outside Genset dimensions by 12in (300mm).

For single Genset installation, the foundation weight should be a minimum of 1.50 times the Genset wet weight.

For multiple Genset installation, the foundation weight should be a minimum of 2.0 times the Genset wet weight.

Figure 2-2 shows a method to calculate foundation thickness and the soil bearing load of the foundation and Generator Set. The soil load bearing capacity under the foundation must equal or exceed the load from the foundation and Genset. If it does not, then a footing must be added to spread the load over a larger area.

**Caution:** Check the local building codes for load bearing capacity requirements.

**Caution:** If the soil is subject to freezing and thawing, the foundation must be extended below the frost line. Check the local building codes.

**Figure 2-2 Calculate Soil Bearing Load (SBL) Capacity**

$$T = \frac{W_T}{145 \times L \times W}$$

Where:

T = Foundation depth in feet (m)

$W_T$  = Wet weight of Geneset in lbs (kg)

145 = Density of concrete in lbs/ft<sup>3</sup> (kg/m<sup>3</sup>)

L = Foundation length in feet (m)

W = Foundation width in feet (m)

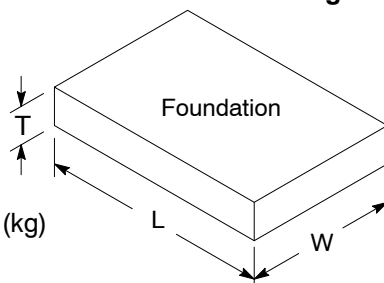

$$SBL = \frac{TW}{W \times L}$$

Where:

SBL = Soil bearing load in lbs/ft<sup>2</sup> (kPa)

TW = Total weight (foundation load Genset (wet) and all other equipment to be supported in lbs (kg))

L = Foundation length in feet (m)

W = Foundation width in feet (m)

Table 2-1 shows approximate load bearing capacities for various types of soil if the actual load bearing capacity of the soil under the foundation is not known.

**Table 2-1 Approximate Load Bearing Capacities of Various Soil Types**

Soil Type	Safe Bearing Capacity	
	lb per ft <sup>2</sup>	kilo Pascals
Hard Rock – Granite etc.	50,000 – 200,000	2,395 – 9,576
Medium Rock – Shale etc.	20,000 – 30,000	958 – 1,436
Hardpan	16,000 – 20,000	766 – 958
Soft Rock	10,000 – 20,000	479 – 958
Compacted Sand and Gravel	10,000 – 12,000	479 – 575
Hard Clay	8,000 – 10,000	383 – 479
Gravel and Coarse Sand	8,000 – 10,000	383 – 479
Loose, Medium and Coarse Sand	8,000 – 10,000	383 – 479
Compacted Fine Sand	6,000 – 8,000	287 – 383
Medium Clay	4,000 – 8,000	192 – 383
Loose Fine Sand	2,000 – 4,000	96 – 192
Soft Clay	2,000	96

- Reinforce the foundation with No. 8 gauge steel wire mesh placed horizontally on 6in (150mm) centers. As an alternative, use No. 6 re-bars on 12in (300mm) centers horizontally. Minimum cover over the bars should be 3in (76mm).
- Suggested concrete mixture by volume is 1 part cement, 2 parts sand, and 3 parts aggregate. Maximum slump of 4in (100mm) and a 28-day compressive strength of 3000 psi (20,600 kPa).
- The size of the bolts holding the sub-base to the foundation should be sized to fit the mounting holes shown on the installation diagram.
- Three-inch (76mm) iron pipe sleeves should be placed around the bolts in the foundation to allow for any mislocation of the bolts after the foundation hardens. “J” or “L” type bolts are recommended for the foundation bolts.
- After the foundation is cured and the Genset is located, the sleeves are filled with grout.

**Exhaust System Exhaust Checklist**

- Exhaust outlets are not located upwind or near any building air intakes.
- Flexible piping section is used at engine exhaust outlet.
- Exhaust piping material is adequate for expected service.
- Exhaust piping sizing is adequate to prevent back pressure.
- Exhaust piping components are insulated as necessary to prevent operator burns and reduce pipe radiant heat losses.
- Pipe sleeves or fire proof materials are used where exhaust pipe passes through building materials as per local and state codes.
- Exhaust pipe includes rain cap or is horizontal.

The purpose of the exhaust system is to safely discharge the engine combustion products into the atmosphere outside the building. A silencer should be installed in the exhaust system to reduce noise levels. Compliance with local noise codes is always required.

**WARNING: Never allow the exhaust outlet to be positioned so that the exhaust gases are directed towards any openings or air entry routes (doors, windows, vents, etc.) of an occupied building. When discharging the hot exhaust gases out of the building do not direct them towards anything that could catch fire or explode.**

For aesthetic reasons, consider exhaust placement in relation to the building. Over a period of time, exhaust gas carbon deposits will tend to accumulate on any nearby wall or structure. Attention must also be given to exhaust noise in selecting placement of the exhaust system.

**Level Of Attenuation**

In general, manufacturers offer multiple grades of silencers: industrial, residential, and critical. Select the silencer to assure the desired level of silencing is met.



## Multi-Engine Installations

**Caution:** Do not connect multi-engine exhaust systems together. Each engine must have its own exhaust system for proper operation.

Exhaust gases from an operating engine will migrate back through a non-operating engine and cause a hydraulic lock. This may interfere with starting of the second engine. The migrating gases will also tend to turn the turbos which are not being provided lubrication if the engine is not running. Do not use check valves in the exhaust system because they can "stick".

### Exhaust Manifold

There are two exhaust manifold types. Dry type which is standard and the optional water cooled. The dry type is simply exposed to the surrounding air and becomes very hot. Shields, insulating wraps, or other types of guards can be used to limit operator contact with the hot surfaces. This practice is common where engine room size is small, creating cramped conditions.

Water cooled exhaust manifolds are not available on all engine models. This type manifold has passages through which engine coolant is circulated to remove heat from the manifold surface. It also will help protect the operator from contact with the hot manifold surface. This will reduce the amount of heat that is radiated by the engine to the surrounding air by approximately 20%. In addition, this type manifold significantly increases the amount of heat the cooling system must dissipate. Marine and Mining Safety Administration (MSA) codes may require water cooled manifolds in all Genset installations. If you are in doubt on your particular application, consult your Baldor Distributor.

Note: If you are using a remote muffler a flexible coupling of 12" or more must be installed between the exhaust line and the manifold to absorb the engine's vibration. However, a short, solid section of pipe between 6" and 8" long should be placed between the connection of the manifold and the flexible coupling. This nipple will reduce the possibility of the hot gases burning up the flexible coupling.

### Exhaust Gas Restriction

The maximum allowable back pressure, or system restriction, is stated in the product specifications data (inches Hg). If this back pressure is exceeded, the air-fuel ratio is reduced due to incomplete scavenging of the cylinders, fuel economy and power output is reduced, engine life is reduced and exhaust temperatures and smoke levels increase. Any restriction of the exhaust gas reduces horsepower. Take every precaution to reduce restriction. Proper design and installation will provide safe Genset operation.

It is essential that engine exhaust systems have the least possible restriction to exhaust gas flow. This can be calculated as shown in Figure 2-3.

**Figure 2-3 Exhaust System Calculations**

$$P \text{ (psi)} = \frac{L \times SL \times Q^2}{5,184 \times D^5}$$

Where:

P = Backpressure in psi (kPa)

psi = 0.4912 x in Hg

kPa = 0.1333 x in Hg

L = Length of pipe in ft (m)

Q = Exhaust gas flow ft<sup>3</sup>/min (m<sup>3</sup>/min)

D = Inside diameter of pipe in (mm)

S = Specific weight of gas lb/ft<sup>3</sup> (kg/m<sup>3</sup>)

$$S \text{ (lb/ft}^3\text{)} = \frac{39.6}{\text{Exhaust Temperature} + 460^\circ\text{F}}$$

$$S \text{ (kg/m}^3\text{)} = \frac{352.05}{\text{Exhaust Temperature} + 273.16^\circ\text{C}}$$

To obtain equivalent length of straight pipe for each long radius 90° bend:

$$L \text{ (ft)} = 15 \times D \quad L \text{ (m)} = 15 \times D$$

$$L \text{ (in)} = \frac{15 \times D}{12} \quad L \text{ (mm)} = \frac{15 \times D}{1000}$$

Note: For 90° bends, radii of 1.5 times pipe diameter helps reduce resistance and backpressure.

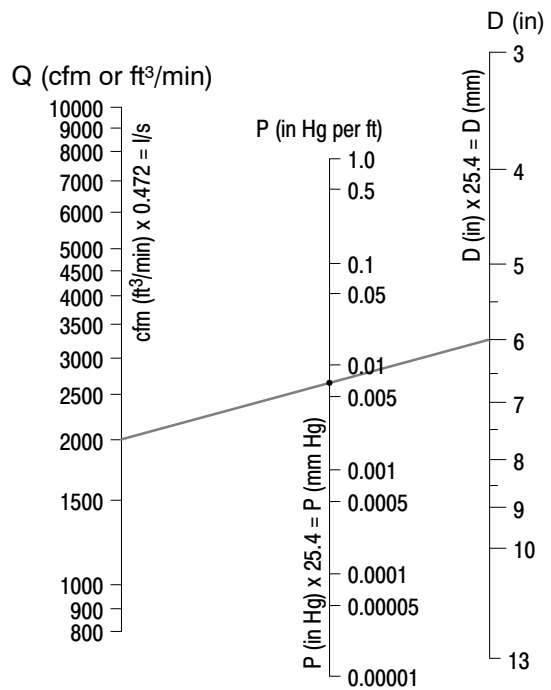

## Exhaust Piping

**Caution:** The weight of the exhaust system must never be imposed on the turbo-charger outlet. Damage to the turbo-charger and other components may result.

An exhaust system must withstand the vibration and thermal expansion that they are subjected to, yet supported well enough to remain independent of the engine.

The most common method of providing flexibility is with the use of bellows type flexible piping. This piping component allows lateral and linear movement of the piping system without subjecting fixed components to excessive stress. A minimum of 12 inches of flexible connection must be provided at the engine exhaust manifold to allow for thermal expansion and vibration. If the engine is to be mounted on spring type vibration isolators, increase the length to 24 inches. This component can be specified to be provided by your Baldor distributor. Flexible pipe should never be used for pipe bends or to cure misalignment problems.

Exhaust piping systems may be supported by a wide variety of methods to long as the system remains flexible, and capable of withstanding thermal expansion.

The material most commonly used for straight runs and elbows in exhaust systems is Schedule 40 black iron. If hanging weight is a problem, other materials may be used. Galvanized piping should never be used in exhaust system. Where exhaust piping passes through combustible material, exhaust thimbles must be used. See Figure 2-4.

**Note:** Water is one of the by-products of combustion. This water must be kept from draining back into the engine. Slanting the horizontal section of the exhaust system piping downward slightly, away from the engine can do this. A water trap (tee extension with a drain cock) should also be used. The water trap should be located between the flex coupling and the muffler, but as close to the engine as possible on a horizontal section of the exhaust piping.

**Figure 2-4 Exhaust Pipe Thimble Installation**

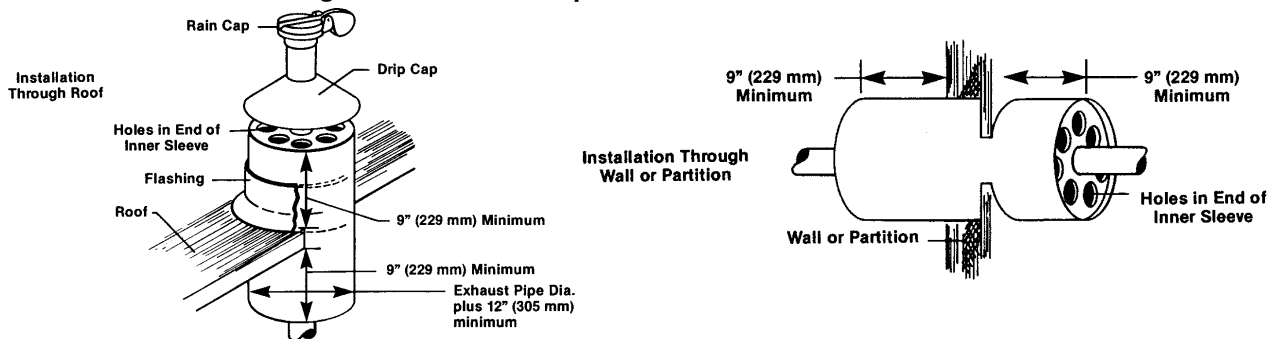

**Wind Barrier** Wind blowing against air exhaust or intake openings of the Genset room must be considered, especially where the radiator and fan are located on the engine. Wind blowing against an exhaust opening creates restriction to the fan. Wind blowing against intake openings can blow open gravity louvers causing low temperature and moisture problems in bad weather. A turning vane may be required to prevent exhaust air recirculation between the exhaust louvers and the barrier surface. This will route the exhaust upward into the atmosphere.

### Rain Protection

Moisture entering the engine through an exhaust system can cause extensive damage. Exhaust outlets must have a rain cap or be horizontal to prevent such damage, see Figure 2-4.

## Transfer Switch Transfer Switch Checklist

- A. Locate transfer switch in a clean, dry place, near the emergency load.
- B. Provide a circuit breaker between the Genset and the transfer switch.
- C. Put a flexible connection between the conduit and Genset.
- D. Observe applicable codes in wiring—in the transfer switch and Genset.

The transfer switch connects the Genset to the emergency power system. The emergency power system may include several Gensets and several transfer switches. Typically, the Genset is wired to the emergency power system through a transfer switch as shown in Figure 2-5.

**Figure 2-5 Typical Emergency Power System Installations**

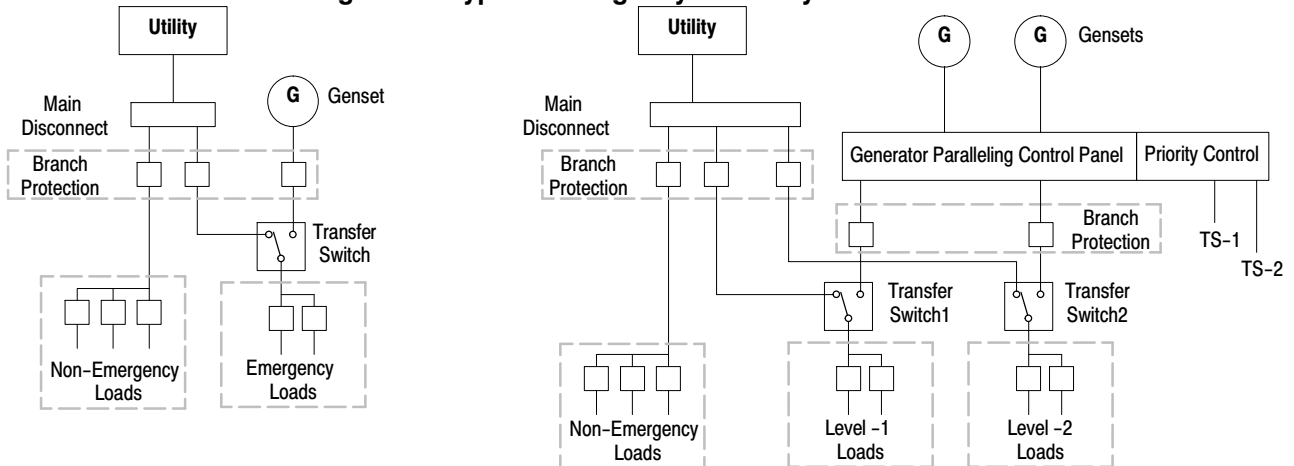

Multiple Gensets can be arranged either in parallel or separately connected to dedicated emergency loads. Figure 2-5 also shows a typical arrangement of two Gensets in parallel with transfer switches for loads that have different levels of priority. A typical multiple Genset installation is shown for NFPA 110 Level 1 and Level 2 emergency power circuits and a priority control to select the appropriate transfer switch.

Wattmeters should be installed on each Genset so load sharing can be checked. The control system should include an automatic paralleling control. Paralleling identical Gensets is not difficult, but paralleling dissimilar sets can cause load sharing problems. When designing an installation that includes the paralleling of dissimilar generators, contract your nearby Baldor Distributor.

## Transfer Switch Location

The transfer switch location is important and key considerations are:

1. Locate the transfer switch as close to the emergency load as practical to avoid interruptions of the emergency power system due to natural or man-made disasters, or to equipment failures. Consider several small transfer switches instead of one large one to increase reliability.
2. Locate the transfer switch in a clean, dry, well ventilated location, away from excessive heat. When the ambient air is above 104 °F (40 °C), fuses and circuit breakers must be derated. Allow adequate working space around the transfer switch.
3. A circuit breaker (or fuses) should be installed in the line between the generator and the transfer switch. Baldor Gensets are available with properly sized circuit breaker built into the generator control. The circuit breaker can be separately mounted. In the case of very large circuit breakers, a separate floor mounted circuit breaker may be easier to wire up than a wall mounted breaker.
4. Install power and control wires in separate solid conduit with flexible sections at the Genset. The flexible sections prevent vibration from damaging the conduit. All power conduits from the Genset must contain all three phases.
5. Never install control wires in the same conduit as power conductors.
6. Conduit, wire, circuit protective device sizes, insulation etc. must conform to applicable local and national codes and regulations.
7. Be certain to seal around conduits that penetrate the walls of the Genset room to reduce the amount of noise that is transmitted to the surrounding areas of the building and maintain site fire code rating.

---

## **Battery Starting System**

This section describes the battery starting system (nominal 12 or 24 volt rating of the battery supply) for the engine, battery charger, and precautions to take if the ambient temperature is expected to be below 70 °F (20°C).

**WARNING: If batteries are not mounted in the battery rack supplied with the Genset, protect batteries from vibration and do not locate them near a source of flame or spark. A battery presents a risk of fire and explosion because they generate hydrogen gas. Hydrogen gas is extremely explosive. Never jump start a battery, smoke in the area around the battery or cause any spark to occur in the area around the battery.**

### **Battery Location**

Locate batteries as close as possible to the Genset to minimize starting circuit resistance, see Figure 2-6. High starting circuit resistance substantially reduces starting cranking ability. The Genset data sheet lists the maximum allowable cranking system resistance. Mount batteries on a level rack away from dirt and liquids. Allow space for servicing (checking water level and level of charge). Baldor Gensets can be ordered with battery racks already installed. Cold ambient temperature at the battery location substantially reduces the battery output.

**Figure 2-6 Battery Starting System**

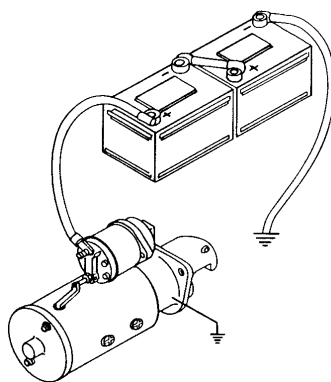

**Battery Size** The ability to start the engine depends upon battery capacity, ambient temperature and coolant and oil temperatures. The Engine/Generator Set Data Sheet lists minimum recommended battery capacity at various ambient temperatures. The recommended battery capacities are listed in the Electric Systems section of the Engine Data Sheet, cold cranking amps (CCA) at 0 °F (-18 °C). Battery capacities decrease as ambient temperatures decrease so it is important to specify batteries with the appropriate CCA rating at a temperature no higher than the minimum ambient temperature for the application.

**Battery Charger** An engine mounted alternator to charge the batteries during operation is an available option. Standby Gensets require a solid state battery charger that is connected to utility power so the battery is charged continuously while the Genset is not running. The battery charger should be connected to the emergency circuit. The batteries on prime power Gensets are charged by the engine mounted alternator, if equipped.

Harmonic wave forms from solid state battery charges and belt driven alternators can cause the electronic governor on the engine to act erratically. To avoid this, the output of the battery charger or the belt driven alternator must be connected directly to the battery or to the battery terminals on the starter. Make control connections to the Genset control using a conduit with a flexible section at the Genset to avoid damage due to Genset vibrations.

**Battery Cables** The wire size (wire gauge) of the cables connecting the starter to the batteries must be large enough to ensure the resistance of the cranking circuit is less than the “Maximum Allowable Resistance of the Cranking Circuit” as shown on the Engine–Generator Set Data Sheet. The total cranking circuit resistance includes the resistance of the cables from the starting motor to the battery and the resistance of all relays, solenoids, switches, and connections. The resistance of various sizes of cables is shown in Figure 2-7. For purposes of calculating cranking circuit resistance to select cable size, the resistance of each connection can be taken as .00001 ohms and the resistance of each relay, solenoid, and switch can be taken as .0002 ohms. Figure 2-7 illustrates an example of a typical cranking circuit resistance calculation.

**Figure 2-7 Typical Battery Cable Calculations**

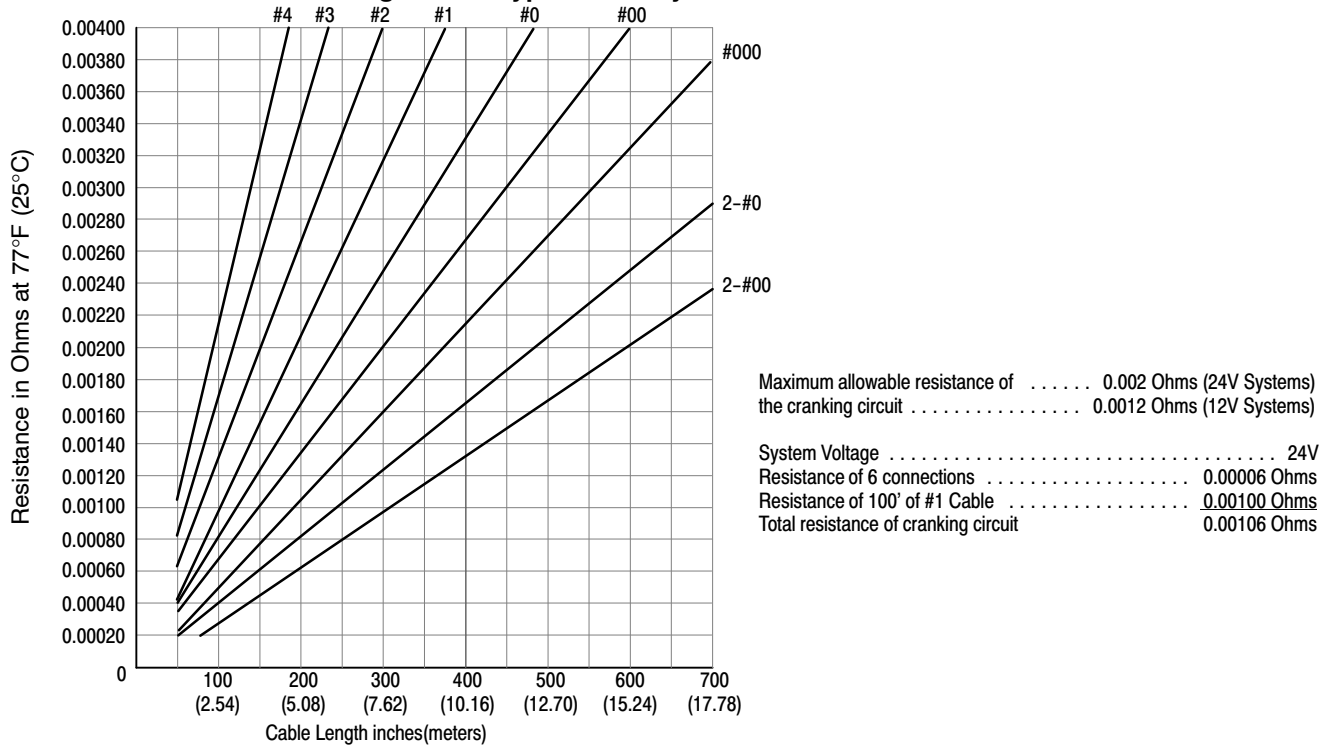

---

## Formulas

### Single Phase – Electric

Single Phase Power Factor is typically 1.0  
1 kW = 1 kilo Watt = 1,000 Watts

$$\text{Watts} = \text{Volts} \times \text{Amps} \times \text{Power Factor}$$

$$\text{Amps} = \frac{\text{Watts}}{\text{Volts} \times \text{Power Factor}}$$

### Three Phase – Electric

Three Phase Power Factor is typically 0.8  
1 kW = 1 kilo Watt = 1,000 Watts

$$\text{Watts} = (\text{Volts} \times \text{Amps} \times \text{Power Factor}) \times 1.732$$

$$\text{Amps} = \frac{\text{Watts}}{\text{Volts} \times \text{Power Factor} \times 1.732}$$

### Length

inches x 25.40 = mm  
feet x 0.305 = m  
yard x 0.914 = m

mm x 0.03937 = inches  
m x 3.280 = feet  
m x 1.094 = yard

### Area

inches<sup>2</sup> x 6.451 = cm<sup>2</sup>  
feet<sup>2</sup> x 0.0929 = m<sup>2</sup>

cm<sup>2</sup> x 0.394 = inches<sup>2</sup>  
m<sup>2</sup> x 10.764 = feet<sup>2</sup>

### Pressure

pounds/ft<sup>2</sup> x 0.006944 = pounds/in<sup>2</sup>  
psi x 6.8948 = kPa  
psi = 0.4912 inches Hg

pounds/in<sup>2</sup> x 144 = pounds/ft<sup>2</sup>  
kPa x 0.1450 = psi  
kPa = 0.1333 x inches Hg

### Temperature

$$^{\circ}\text{C} = (^{\circ}\text{F} - 32) \times 0.55555$$

$$^{\circ}\text{F} = (^{\circ}\text{C} \times 1.8) + 32$$

### Torque

oz-in x 0.007062 = Nm  
lb-in x 0.11296 = Nm  
lb-ft x 1.356 = Nm

Nm x 141.6029 = oz-in  
Nm x 8.8495 = lb-in  
Nm x 0.7376 = lb-ft

### Velocity

ft/sec x 0.3048 = m/sec  
miles/hr x 1.6093 = km/hr  
miles/hr x 0.44704 = m/sec

m/sec x 3.2808 = ft/sec  
km/hr x 0.6214 = miles/hr  
m/sec x 3.2808 = ft/sec  
m/sec x 2.2369 = miles/hr

### Volume

inches<sup>3</sup> x 16.388 = mm<sup>3</sup>  
feet<sup>3</sup> x 0.0283 = m<sup>3</sup>  
gallons x 3.785 = liter  
gallons x 0.13337 = ft<sup>3</sup>

cm<sup>3</sup> x 0.06102 = inches<sup>3</sup>  
m<sup>3</sup> x 35.315 = feet<sup>3</sup>  
liter x 0.2642 = gallon

### Miscellaneous

Watt x 0.00134 = hp or 746 watts = hp  
BTU/hr x 0.293 = Watts  
BTU/hr x 0.0003929 = hp

Watts x 3.4122 = BTU/hr  
hp x 2,545 = BTU/hr

Approximate fuel Higher Heating Values (HHV):

Natural Gas = 1015 BTU/ ft<sup>3</sup>, Liquid Propane = 2650 BTU/ ft<sup>3</sup>

Effect of engine efficiency on fuel consumption:

$$\frac{\text{hp} \times 2545 \text{ BTU/hr per hp}}{0.25 \text{ efficiency}} = 10,180 \text{ BTU/hr}$$

## Section 3 Receiving & Installation

**Receiving & Inspection** When you receive your Genset, there are several things you should do immediately.

1. Observe the condition of the shipping container and report any damage immediately to the commercial carrier that delivered your system.
2. Verify that the part number of the system you received is the same as the part number listed on your purchase order.
3. If the system is to be stored for several weeks before use, be sure that it is stored in a location that conforms to published storage temperature and humidity specifications.

**Lifting the Genset** When lift or hoist equipment is used to lift the Genset and move it to position, be careful not to contact overhead wires or other obstacles. Be sure lift or hoist equipment has appropriate tires for the terrain to avoid becoming stuck or tipping over. If the shipping pallet is intact, use a fork lift to move the Genset. If the shipping pallet has been removed, use two steel pipes through the "Lift Point" holes to lift the Genset. See Figure 3-1.

**Figure 3-1 Genset Lifting**

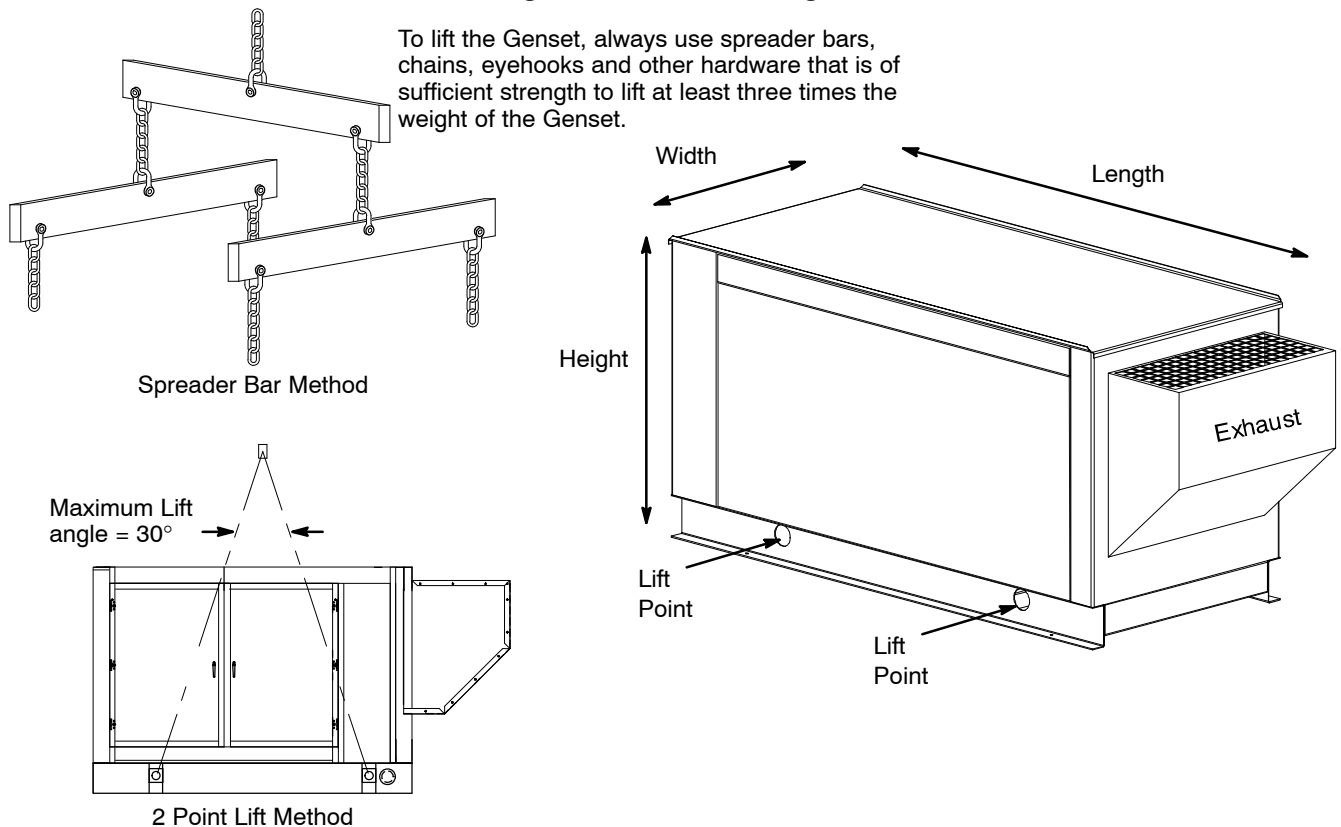

**WARNING: An open bottom stationary engine Genset must be installed over noncombustible materials and shall be located such that it prevents combustible materials from accumulating under the Genset.**

**Physical Location** The mounting location of the system is important. It should be installed in an area that is protected from direct harmful gases or liquids, dust, metallic particles, shock and vibration. It should be installed in an outdoor location so the exhaust fumes are vented to the atmosphere.

### **When the Genset is installed outdoors**

The factory installed enclosure is designed to keep out undesirable weather elements while providing cooling and ventilation.

### **When the Genset is installed in a building it is essential to provide:**

1. Adequate control and exhausting of the heated air.
2. An adequate and constant supply of incoming cooling air.
3. Adequate control and discharge of the engine's hot exhaust gases.
4. Adequate ventilation of the building when the engine shuts down.

---

Several other factors should be carefully evaluated when selecting a location for installation:

1. For effective cooling and maintenance, the system is mounted on a flat, smooth, noncombustible level surface. A concrete pad is ideal.
2. Installation should prevent water levels from reaching the Genset. Drainage must be adequate to keep concrete pad free from standing water.
3. Installation should prevent obstructions by buildup of leaves, grass, sand, snow, etc. If these items pose a problem, consider building a small fence or other break to protect the unit from accumulation of debris.
4. Installation should place the Genset as close as possible to the fuel supply and transfer switch.
5. At least thirty-six (36) inches clearance must be provided on all sides for air flow.
6. Access must be provided to allow the enclosure covers to be opened or removed for service and maintenance.
7. Maximum Ambient temperature is 122°F (50°C).

### **Secure the Genset**

Mounting bolts in the base frame secure the Genset to the shipping pallet. Remove these bolts, lift the Genset and remove the shipping pallet.

Secure the Genset to the concrete pad using  $\frac{3}{8}$ " anchor hardware (not provided) in the base frame mounting holes. See Figure 3-2.

Anchor bolts must be long enough to extend through the Genset mounting frame.

**Engine Cooling** A sufficient flow of clean, cool air is required for combustion and to dissipate the heat produced by the engine. Approximately 60% of the heat value of the fuel used is given off as heat (cooling air and exhaust).

The air that will cool the engine must be brought in from outside the building. A sufficient air-flow of rate "Cubic Feet per Minute" (CFM) will allow the incoming fresh air to cool the engine. This requires a power ventilation system of sufficient CFM to be located at the highest possible point of the building to exhaust hot air and draw in cool fresh air.

Note: The exhaust fan must not be located where it could easily become blocked by leaves, snow, water, debris, etc.

It is recommended that the cool air intake have at least three (3) times the cross-sectional area of the power ventilation system. It is also recommended that the cool air intake be located as close as possible to the top of the Genset.

The exhaust fan must be connected to the AC power terminals of the Genset so that when the Genset starts it will provide immediate cooling air flow. The fan will operate until the Genset stops. To test the ventilation system, do the following:

#### **Ventilation Test**

1. Place a thermometer as close to the cool air intake of the engine's blower housing as you can without allowing the thermometer to touch any material surface.
2. Place another thermometer outside of the building or compartment in the open air (Keep the thermometer out of direct sunlight or any other heat sources).
3. Run the engine under maximum load for an extended period of time (at least one hour).
4. The temperature difference between the two should not exceed 15 degrees F.

Note that opening any door, window or other opening can upset the air-flow pattern and result in a significant reduction in the cooling air-flow across the Genset. This may result in overheating, fire, or explosion.



Figure 3-2 Genset Mounting 10–25kW

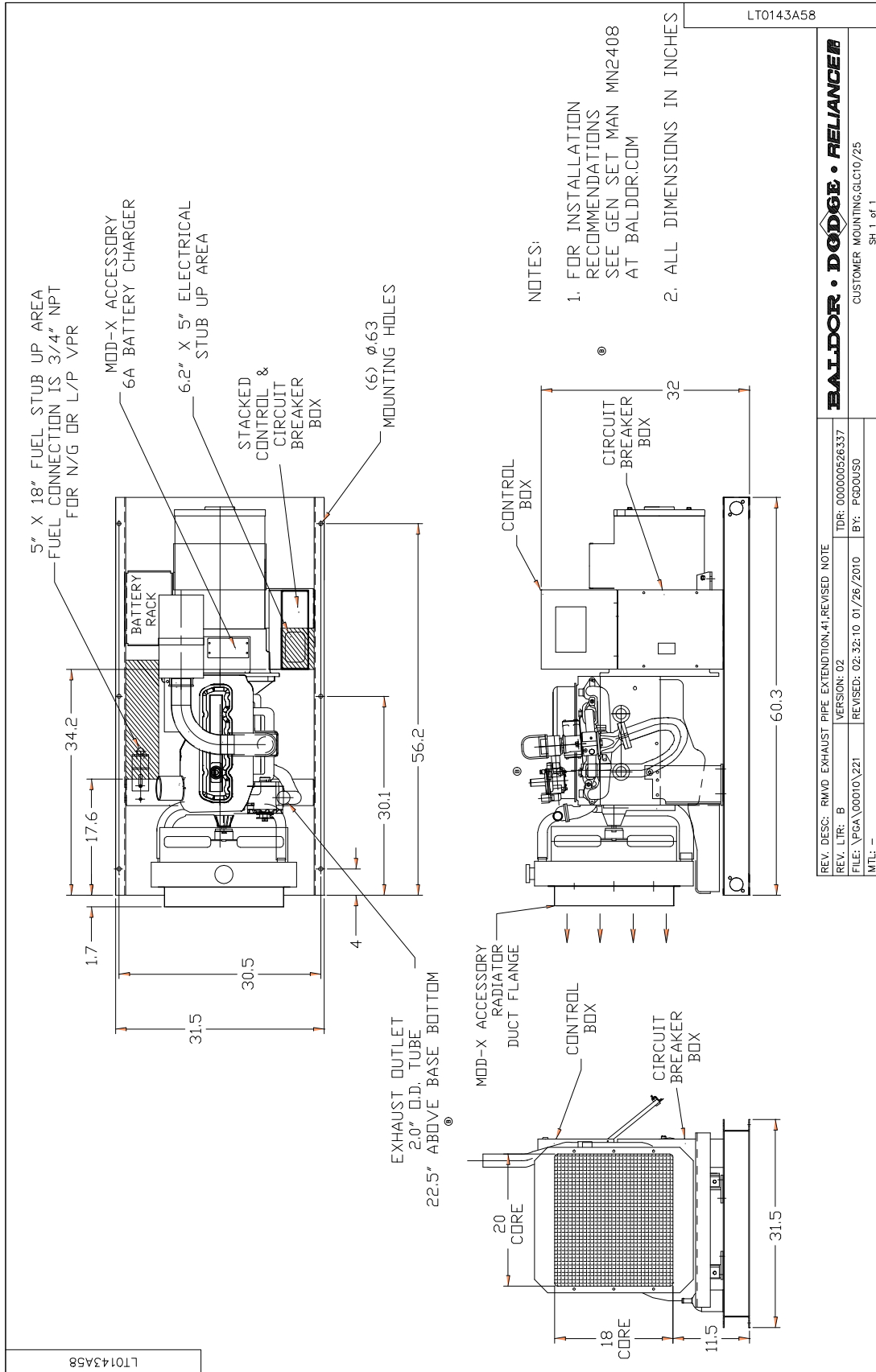
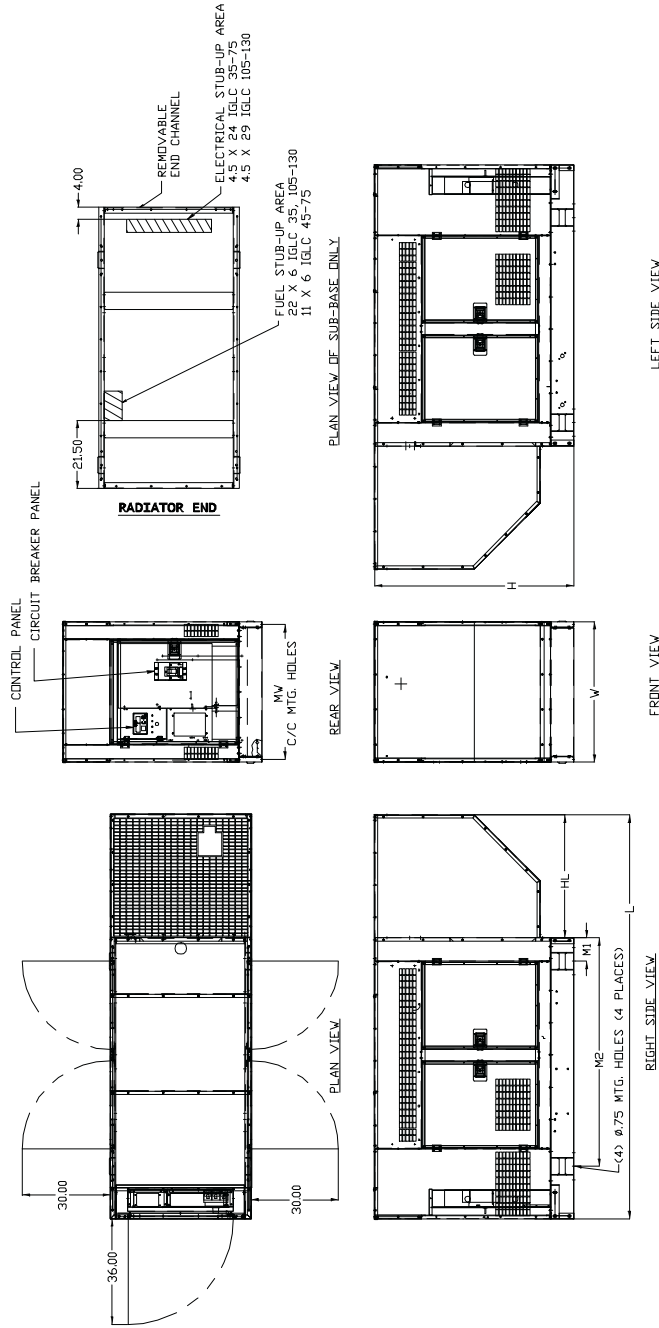

**Table 3-2 Mounting Dimensions 35-130kW**

UL2200 MODEL #	MODEL #	OVERALL LENGTH L	OVERALL WIDTH V	OVERALL HEIGHT H	HOOD LENGTH HL	MOUNTING HOLES 1 MH	MOUNTING HOLES 2 ME	MOUNTING WIDTH MW
IGLC35-2GU	IGLC35-2G	97	36	48			58.00	34.00
IGLC45-2GU	IGLC45-2G	105			21	10.00	67.00	
IGLC55-2GU	IGLC55-2G	111	42	56			73.00	40.00
IGLC75-2GU	IGLC75-2G							
IGLC105-2GU	IGLC105-2G	138	48	68	42	8.00	78.00	46.00
IGLC130-2GU	IGLC130-2G							

**BALDOR**  
**GENERATORS**  
 GENERAL INSTALLATION  
 FOR IGLC GENERATORS

SLS-IGLC-35-130-09E



**NOTES:**

FOR PRODUCT DATA REFER TO BALDOR MODEL SPEC SHEETS  
 FOR INSTALLATION RECOMMENDATIONS REFER TO GEN SET MANUAL, INC-400

ALL DIMENSIONS IN INCHES  
 ALL WEIGHTS IN POUNDS

DRAWING TO SCALE

TOLERANCES UNLESS OTHERWISE SPECIFIED  
 DECIMALS .XX ±.25 FRACTIONS ±1/4

WEIGHTS SHOWN ARE TYPICAL AND INCLUDE ALTERNATORS SELECTED @ 125° C RISE

STRAINER REDUCES THE FUEL STUB-UP AREA BY 4.5" FOR IGLC 35, 6.5" FOR IGLC 45-75 AND 8.0" FOR IGLC 105-130

SLS-IGLC-35-130-09E

**BALDOR • DODGE • RELIANCE**

SLS-IGLC-35-130-09E

SH 1 of 2

REV. DESC: NEW DRAWING	VERSION: 00	TDR: 000000519245
REV. LTR: -	REVISED: 08.32.08 12/18/2009	BY: PGDOU50
FILE: \PCG\00016\176	MTL: -	

**Table 3-3 Mounting Dimensions 35-130kW Continued**

IGL200 MODEL #	MODEL #	OVERALL LENGTH L	OVERALL WIDTH W	OVERALL HEIGHT H	CORE HEIGHT 1 CH1	CORE HEIGHT 2 CH2	CORE WIDTH CV	Mounting Holes 1 MI	Mounting Holes 2 M2	Mounting Width MW	NET WEIGHT (#) ±5%
IGLC35-2GU	IGLC35-2G	76	36	36	14	18	19	10.00	58.00	34.00	1340
IGLC45-2GU	IGLC45-2G	84	45	45	11	25	23		67.00	40.00	1592
IGLC55-2GU	IGLC55-2G	90	42	40	11	25	23		73.00	40.00	2024
IGLC75-2GU	IGLC75-2G	96	48	56	14	28	34	8.00	78.00	46.00	2103
IGLC105-2GU	IGLC105-2G										2635
IGLC130-2GU	IGLC130-2G										2830

**RADIATOR END**

**LEFT SIDE VIEW**

**REAR VIEW**

**RIGHT SIDE VIEW**

**PLAN VIEW**

**FRONT VIEW**

**PLAN VIEW: STUB-UPS ONLY**

**FRONT VIEW: STUB-UPS ONLY**

**BALDOR  
GENERATORS**  
GENERAL INSTALLATION  
FOR IGLC GENERATORS

NOTES:  
FOR PRODUCT DATA REFER TO BALDOR MODEL SPEC SHEETS  
FOR INSTALLATION RECOMMENDATIONS REFER TO GEN SET MANUAL M2400  
ALL DIMENSIONS IN INCHES  
ALL WEIGHTS IN POUNDS  
DRAWING TO SCALE  
TOLERANCES UNLESS OTHERWISE SPECIFIED DECIMALS .XX ±.05 FRACTIONS ±1/4  
WEIGHTS SHOWN ARE TYPICAL AND INCLUDE ALTERNATORS SELECTED @ 15°C RISE  
STRAINER REDUCES THE FUEL STUB-UP AREA BY 4.5" FOR IGLC 35, 6.5" FOR IGLC 45-75 AND 8.0" FOR IGLC 105-130

SLS-IGLC-35-130-09E

**BALDOR • DODGE • RELIANCE**  
REV. DESC: NEW DRAWING  
REV. LTR: -  
FILE: \PCA\00016\176  
MPL: -  
VERSION: 00  
TDR: 000000519245  
BY: PG00US0  
REVISED: 08.32.21.12/18/2009

SLS-IGLC-35-130-09E  
SH 2 of 2

---

## Hot Exhaust Gasses

**WARNING:** Exhaust fumes/gases are extremely dangerous and can cause severe illness or death. Never breath exhaust fumes produced by a running engine. Only run the engine outdoors where ventilation is plentiful. Exhaust gases contain carbon monoxide, a colorless, odorless and extremely dangerous gas that can cause unconsciousness or death. Symptoms of carbon monoxide poisoning include: dizziness, nausea, headaches, sleepiness, vomiting or incoherence. If you or anyone else experiences these symptoms, get out into fresh air immediately. Stop the engine and do not restart the engine until it has been inspected and if necessary repaired or reinstalled in a well ventilated area.

**WARNING:** Hot exhaust gasses must never be directed toward anything that may catch fire or explode.

It is extremely important to discharge engine exhaust gasses away from the engine and out of the building. If these gasses remain in the cylinder, poor performance or eventual engine damage may result. This condition results from excessive back-pressure, which could be caused by any one or a combination of the following conditions:

1. Exhaust pipe too long or the diameter is too small.
2. Excessive number of sharp bends in the exhaust system.
3. Obstruction in the exhaust system.

**Backpressure must not exceed 20" of water column.**

The direction of the discharged hot air and hot exhaust gases is important as they have the potential to create brown spots on the lawn or adjacent structures. In extreme cases this extremely hot air could cause dried grass or other debris to ignite.

Exhaust lines should be as short and straight as possible. Long pipe lengths and elbows tend to resist the flow of gases and accumulate carbon deposits. Each pipe fitting and elbow will further restrict the exhaust flow.

### Guidelines for Exhaust System

1. If you are using a remote muffler it should be mounted as close to the engine as possible, since it will clog with carbon if it's operating temperature is too low.
2. If you are using a remote muffler a flexible coupling of 12" or more must be installed between the exhaust line and the manifold to absorb the engine's vibration. However, a short, solid section of pipe between 6" and 8" long should be placed between the connection of the manifold and the flexible coupling. This nipple will reduce the possibility of the hot gases burning up the flexible coupling.
3. It is extremely important that you do not allow the hot exhaust gases to re-circulate into the engine's cooling air intake.
4. Water is one by-product of combustion and is present in the exhaust pipes or muffler. This water must be kept from draining back into the engine. This can be done by slanting the horizontal section of the exhaust system piping downward slightly, away from the engine. A water trap consisting of a tee extension with a drain cock should also be provided. This water trap should be located between the flex coupling and the muffler, but as close to the engine as possible on a horizontal section of the exhaust piping.
5. It is also recommended that an exhaust rain cap be used whenever it is possible that rain could get into the system. This will help to prevent corrosion and damage to the exhaust system and engine.
6. The exhaust system is subject to the engine's vibration and it must therefore be solidly secured to reduce mechanical stress and the potential for breakage.
7. The engine's exhaust system is the hottest component of the installation and extreme care and considerations must be given to it.
8. As much of the exhaust piping as possible should be located near the power ventilation exhaust. This will reduce the radiant exhaust heat inside the building.
9. Keep all fuel and its associated piping away from all components of the engine exhaust system.
10. After the exhaust system is installed it should be inspected on a regular basis to assure there are no toxic exhaust gas leaks. In some areas this inspection may be provided by your local public service.
11. A carbon monoxide tester may be installed to detect the presence of the deadly gas during times when you are in the building with the engine running (during testing or maintenance).

**WARNING:** Never allow the exhaust outlet to be positioned so that the exhaust gases are directed towards any openings or air entry routes (doors, windows, vents, etc...) of an occupied building. When discharging the hot exhaust gases out of the building do not direct them towards anything that could catch fire or explode.

**WARNING:** Exhaust fumes/gases are extremely dangerous and can cause severe illness or death. Never breath exhaust fumes produced by a running engine. Only run the engine outdoors where ventilation is plentiful. Exhaust gases contain carbon monoxide, a colorless, odorless and extremely dangerous gas that can cause unconsciousness or death. Symptoms of carbon monoxide poisoning include: dizziness, nausea, headaches, sleepiness, vomiting or incoherence. If you or anyone else experiences these symptoms, get out into fresh air immediately. Stop the engine and do not restart the engine until it has been inspected and if necessary repaired or reinstalled in a well ventilated area.

**Installation**

The Genset is completely assembled, tested and adjusted at the factory before it is shipped to you. The procedures presented in this manual are suggestions and it is the responsibility of the Owner/Operator to arrange for these procedures to be performed by licensed contractors according to all applicable codes including local codes for your Municipality/City/County and State. External connections required at the time of installation are:

1. Fuel System.
2. Electrical Connections – power wiring (optional transfer switch) and control wiring.
3. Starting Battery.
4. Ground Connection.

After installation, the post installation checks must be performed prior to starting the engine. After these checks have been performed and the system operation is verified to be good, refer to Section 5 Maintenance for periodic checks that must be performed at scheduled intervals to ensure continued operation with minimal problems.

**Fuel Connections**

Fuel selection is Natural Gas or LPV (Liquid Propane Vapor). A fuel selection jumper is located at customer terminal block TB1. The jumper must be correctly set for the type of fuel being used by the genset.

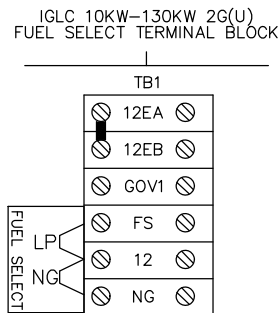

If natural gas supply is used, follow the “Natural Gas Connections” procedure. If LPV supply is used, follow the “LP Vapor Connections” procedure. Table 3-4 defines the flow rate required for each fuel type.

**Table 3-4 Fuel Consumption Natural and LPV**

Catalog Number	Model Number	Fuel Consumption at 100% load cubic ft/Hr (cubic m/Hr)		Catalog Number	Model Number	Fuel Consumption at 100% load cubic ft/Hr (cubic m/Hr)	
		Natural Gas	LP Vapor			Natural Gas	LP Vapor
GLC10M240LS	IGLC25-2GU	203(5.8)	86(2.4)	GLC72M240LS	IGLC75-2GU	790(22.4)	330(9.3)
GLC15M240LS	IGLC25-2GU	247(7.0)	108(3.1)	GLC32M208MS	IGLC35-2GU	430(12.2)	175(5.0)
GLC20M240LS	IGLC25-2GU	300(8.5)	131(3.7)	GLC44M208MS	IGLC45-2GU	584(16.5)	246(7.0)
GLC25M240LS	IGLC25-2GU	365(10.3)	154(4.4)	GLC54M208MS	IGLC55-2GU	744(21.1)	295(8.4)
GLC30M240LS	IGLC35-2GU	430(12.2)	175(5.0)	GLC73M208MS	IGLC75-2GU	790(22.4)	330(9.3)
GLC43M240LS	IGLC45-2GU	585(16.5)	246(7.0)	GLC105M208MS	IGLC105-2GU	1164(33.0)	511(14.5)
GLC55M240LS	IGLC55-2GU	744(21.1)	295(8.4)	GLC128M208MS	IGLC130-2GU	1650(46.7)	580(16.4)

The following pamphlets are available from:  
 National Fire Protection Association (NFPA) P.O. Box 9101 Quincy, MA 02269  
 No. 37 – Combustion Engines  
 No. 54 – Gaseous Appliances and piping  
 No. 58 – Storage and handling LPV

**Example: Determining Pipe Size for Natural Gas**

A Genset has a 16Hp engine 60 feet from the supply. An engine needs 10,000 BTU/hr per hp to run efficiently. For Natural Gas fuel there are 1015 BTU/ft<sup>3</sup>

Determine the supply pipe size for Natural Gas fuel.

16hp x 10,000 BTU/Hr per hp = 160,000 BTU's / per hour for proper operation.

$$\frac{160,000}{1,015} = 158 \text{ cubic feet per hour.}$$

From Table 3-5, a 60 foot run requires a minimum 1" pipe at full engine load.

**Natural Gas Connections**

The incoming pressure must be 11 inches water column (6 oz. pressure).

**Table 3-5 Natural Gas Flow Rate (Cubic Feet per Hour) per Pipe Length**

Pipe Length (Feet)	Iron Pipe Size										
	1/2"	3/4"	1"	1-1/4"	1-1/2"	2"	2-1/2"	3"	4"	6"	8"
15	73	165	332	722	1174	2386	3704	6253	13352	37229	
30	50	115	232	515	818	1712	2646	4521	9331	26330	53728
45	41	95	191	418	673	1419	2213	3752	7600	22462	43867
60	37	83	166	366	587	1241	1924	3319	6542	18595	37999
75		74	149	332	524	1077	1684	2886	5772	16652	33959
90		67	137	298	433	962	1501	2597	5291	15200	31025
105		63	126	274	415	885	1376	2357	4906	14064	28715
120			115	260	404	827	1289	2213	4618	13160	26859
150			105	233	366	750	1174	2011	4185	11775	24050
180			96	216	337	693	1077	1876	3848	10736	21934
210			89	197	308	635	991	1712	3559	9937	20298
240				183	289	596	933	1616	3357	9235	18990
270				171	274	558	875	1520	3127	8658	17903
300				164	260	524	827	1433	2886	8177	16998

Note: Almost all operation problems are related to the installation techniques used. Do Not guess, be sure pipe size is adequate for required flow rate.

1. Connect the proper size gas pipe at the Inlet Connection to the Fuel Lock Solenoid. Connect the Natural Gas pipe line shown in Figure 3-3 using the correct size pipe for the required flow rate and length of pipe. Refer to Table 3-5 for pipe size. Be certain that all connections are sealed and no leaks are present. The installer must ensure that all gas connections comply with all building codes.
2. Verify Fuel Supply Pressure  
Prior to initial operation of Genset, verify that fuel system pressure is 11" Water Column (6 oz. pressure) and fuel pipe sizes comply with Table 3-5.
3. To run on NG fuel, install jumper on TB1 terminals 12 and NG.
4. Proceed to Electrical Connections.

**Example: Determining Pipe Size for LPV**

A Genset has a 16Hp engine 60 feet from the supply. An engine needs 10,000 BTU's per hp to run efficiently. For LP fuel there are 2,650 BTU/ft<sup>3</sup>. Determine the supply pipe size for LP fuel.

16hp x 10,000BTU/Hr per hp = 160,000 BTU's / per hour for proper operation.

$$\frac{160,000}{2,650} = 60.4 \text{ cubic feet per hour.}$$

From Table 3-6, a 60 foot run requires a minimum 1" pipe at full engine load.

**Figure 3-3 Gas Line Connections**

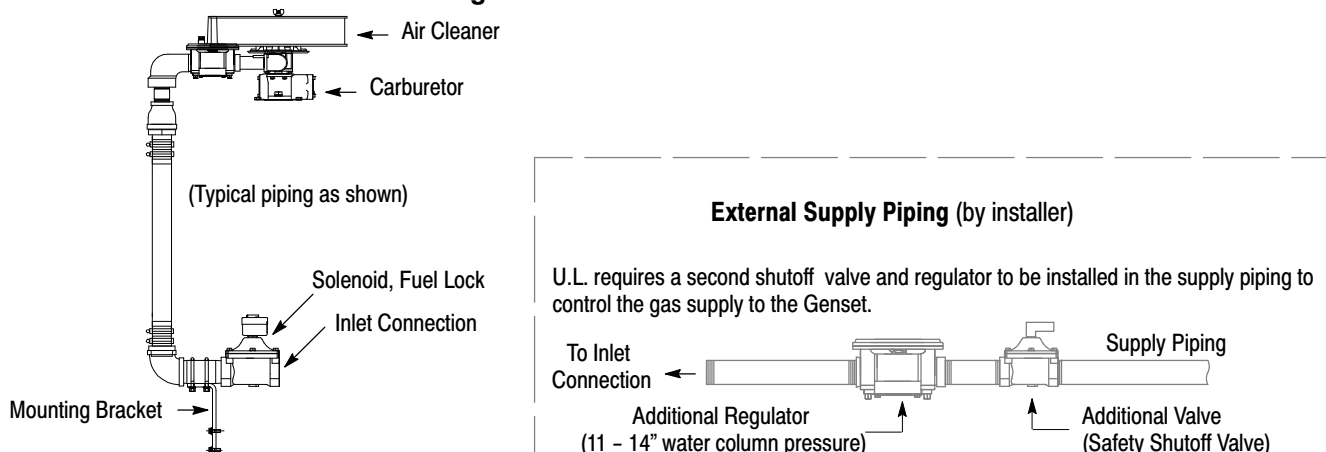

**LP Vapor Connections** (vapor withdrawal only)

The LPV connections should only be made if your Genset is setup to run on LPV. If it is setup to run on Natural Gas, contact your Baldor representative and do not continue with installation. To run on LP Vapor fuel remove the jumper on TB1 terminals 12 and FS.

The incoming pressure must be 11 inches water column (6 oz. pressure).

**Table 3-6 LP Vapor Flow Rate (Cubic Feet per Hour) per Pipe Length**

Pipe Length (Feet)	Iron Pipe Size										
	1/2"	3/4"	1"	1-1/4"	1-1/2"	2"	2-1/2"	3"	4"	6"	8"
15	48	109	218	475	772	1570	2437	4115	8786	24497	50007
30	33	76	153	339	538	1127	1741	2975	6140	17325	35353
45	27	63	126	275	443	934	1456	2469	5001	14781	28865
60	24	54	110	241	386	817	1266	2184	4304	12236	25004
75		49	98	218	345	709	1108	1899	3798	10957	22345
90		44	89	196	310	633	987	1709	3482	10001	20414
105		41	83	180	285	582	905	1551	3228	9254	18895
120			76	171	266	544	848	1456	3038	8659	17673
150			69	153	241	494	772	1323	2754	7748	15825
180			63	142	222	456	709	1234	2532	7064	14432
210			58	130	202	418	652	1127	2342	6439	13356
240				120	190	393	614	1063	2209	6077	12405
270				113	180	367	576	1000	2057	5697	11780
300				108	171	345	544	943	1899	5381	11179

Note: Almost all operation problems are related to the installation techniques used. Do Not guess, be sure pipe size is adequate for required flow rate.

1. Connect the proper size gas pipe at the inlet connection to the Fuel Lock Solenoid. Connect the LPV pipe line shown in Figure 3-3 using the correct size pipe for the required flow rate and length of pipe. Refer to Table 3-6 for pipe size. Be certain that all connections are sealed and no leaks are present. The installer must ensure that all gas connections comply with all building codes.
2. Verify Fuel Supply Pressure  
Prior to initial operation of Genset, verify that fuel system pressure is 11" Water Column (6 oz. pressure) and fuel pipe sizes comply with Table 3-6.
3. To run on LPV fuel, install jumper on TB1 terminals 12 and FS.
4. Proceed to Electrical Connections.

**Electrical Connections** Class 1 wiring methods must be used for field wiring connections to terminals of a class 2 circuit. It is the responsibility of the owner/operator to arrange for these procedures to be performed by a licensed electrical contractor and ensure conformance to all applicable codes including local codes peculiar to your municipality/city/county and state. Wire size and insulation type should be as required by NEC (National Electrical Code) and local codes.

**Warning:** **Never connect this Genset to the electrical system of any building unless a licensed electrician has installed an approved transfer switch. The national electrical code (NEC) requires that connection of a Genset to any electrical circuit normally powered by means of an electric utility must be connected by means of approved transfer switch equipment to isolate the electrical circuit from the utility distribution system when the Genset is operating. Failure to isolate the electrical circuits by such means may result in injury or death to utility power workers due to backfeed of electrical energy onto the utility lines.**

**Warning:** **Incorrect installation of this Genset could result in property damage, injury or death. Connection of the Genset to its fuel source must be done by a qualified professional technician or contractor.**

**WARNING:** **Be sure the system is properly grounded before applying power. Do not apply AC power before you ensure that grounds are connected. Electrical shock can cause serious or fatal injury. NEC requires that the frame and exposed conductive surfaces (metal parts) be connected to an approved earth ground. Local codes may also require proper grounding of Genset systems.**

**Intended Use** The intended purpose of this Genset is to provide emergency power when the main utility power supply is interrupted. Therefore, it is important that all the wiring that connects the Genset with your house, transfer switch, distribution box, battery charger, etc. be properly installed.

**Circuit Protection** Circuit Breaker protection is provided within the Genset. The breaker box is mounted to the Genset prior to shipment (see Genset Mounting diagrams). See "GLC Circuit Breaker & Wire Size" in Appendix B for recommendations.

**Wire Size** Proper lead wire from the circuit breaker to the automatic transfer switch (or load switching device) is mandatory. See transfer switch information for connection information. When connecting the Genset output to an electrical load, a UL listed circuit breaker with the appropriate ratings must be provided within 25 feet of the Genset. Use only copper wires. Genset ratings are given in Table 3-7.

**Table 3-7 Genset Ratings**

Catalog Number	Model Number	Alternator	Voltage	Voltage L-L/L-N	PH	125° Rise Alternator Standby Rating - LP Fuel		125° Rise Alternator Standby Rating - NG Fuel	
						kW/kVA	Amps	kW/kVA	Amps
						GLC10M240LS	IGLC25-2GU	282PSL1714	240
GLC15M240LS	IGLC25-2GU	282PSL1715	240	240/120	1	15/15	63	15/15	63
GLC20M240LS	IGLC25-2GU	282PSL1716	240	240/120	1	20/20	83	20/20	83
GLC25M240LS	IGLC25-2GU	283PSL1717	240	240/120	1	25/25	104	25/25	104
GLC30M240LS	IGLC35-2GU	UCI224C-06	240	240/120	1	30/30	125	30/30	125
GLC43M240LS	IGLC45-2GU	UCI224E-06	240	240/120	1	43/43	179	40/40	167
GLC55M240LS	IGLC55-2GU	UCI224F-06	240	240/120	1	55/55	229	52/52	217
GLC72M240LS	IGLC75-2GU	UCI224G-06	240	240/120	1	72/72	300	67/67	279
GLC32M208MS	IGLC35-2GU	PI144J-311	208	208/120	3	32/40	111	31/39	108
GLC44M208MS	IGLC45-2GU	UCI224D-311	208	208/120	3	44/55	153	41/51	142
GLC54M208MS	IGLC55-2GU	UCI24E-311	208	208/120	3	54/67.5	187	52/65	180
GLC73M208MS	IGLC75-2GU	UCI224G-311	208	208/120	3	73/91	253	67/84	232
GLC105M208MS	IGLC105-2GU	UCI274D-311	208	208/120	3	105/131	364	99/124	344
GLC128M208MS	IGLC130-2GU	UCI274E-311	208	208/120	3	114/142.5	396	128/160	444



## Transfer Switch Considerations

The following are general considerations for the safe use of a transfer switch:

1. The transfer switch should be located inside the building near the main breaker box or the disconnect box.
2. The transfer switch must be kept away from any location that might allow water to get on it.
3. If the transfer switch is mounted outside, it must be protected from the environment and its elements.
4. Do not mount the transfer switch on the Genset.
5. Do not mount the transfer switch where flammable liquids or vapors are present.

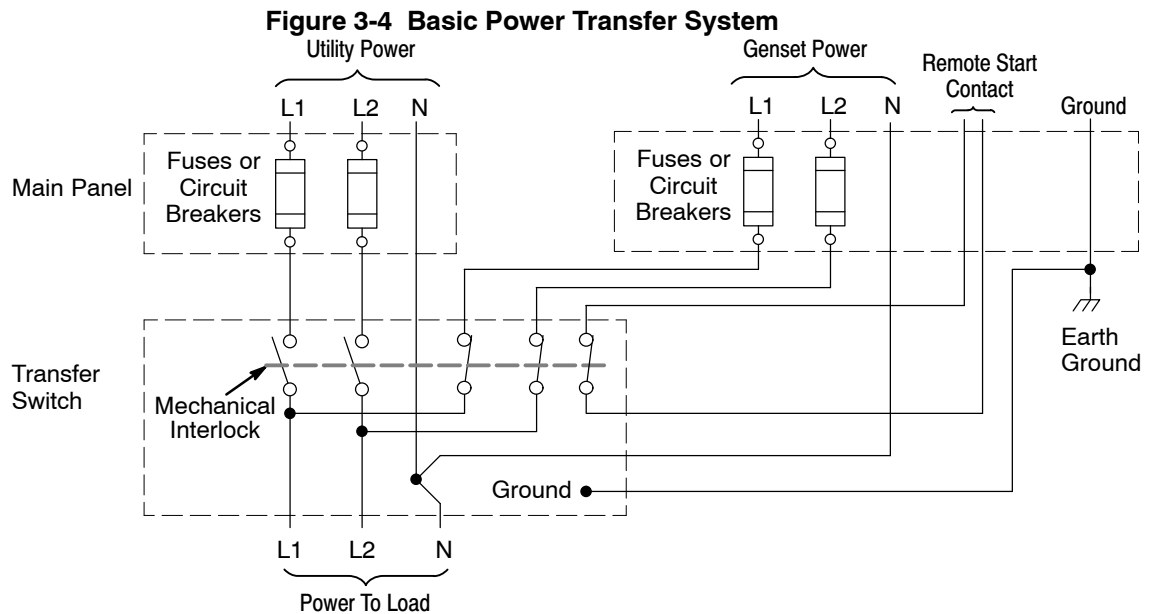

### Remote Start

Connect the remote start contact (from transfer switch) to GLC Remote Start terminals.

### Single Phase Power Connections

Output power connections must be fused within 25 feet of the Genset. If the wires to the transfer switch are shorter than 25 feet, connect L1, L2 and N to the transfer switch being sure to follow NEC and local codes. If the wires to the transfer switch are longer than 25 feet, UL requires that branch circuit protection be provided.

Power connections are made at L1, L2, Neutral and Ground points indicated in the Customer Connections area shown in Figure 3-5.

**Figure 3-5 Single Phase Connections**

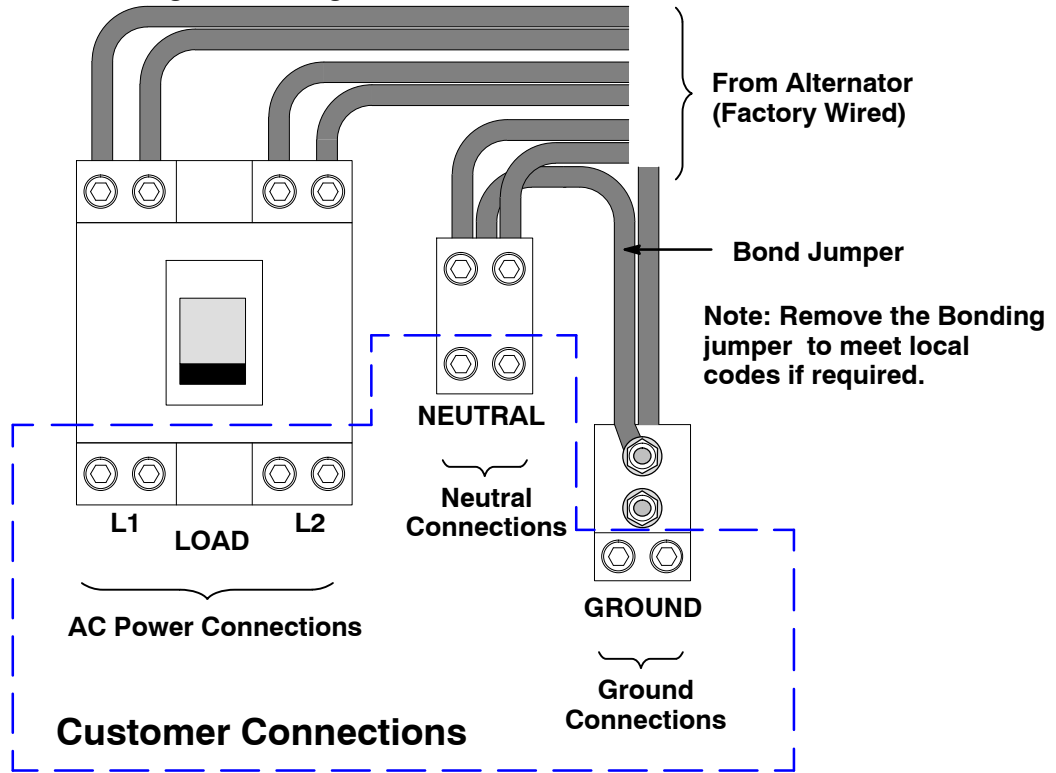

**Figure 3-6 Three Phase WYE and DELTA Connections**

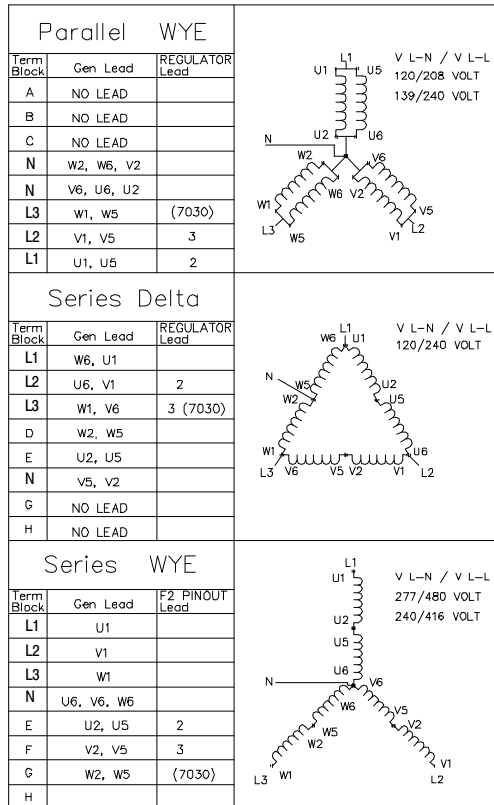

---

## Frame Ground Connection

It is important for safety reasons that the Genset, transfer switch and battery charger share a common Ground and neutral.

The NEC requires that the frame and exposed metal surfaces be at local ground reference potential to avoid electrical shock hazard. A local ground reference may require a driven earth ground conductor at the Genset installation site. Make the ground connection as shown in Figure 3-7. Use the appropriate size wire as required by NEC and local codes.

**Figure 3-7 Frame Ground Connection**

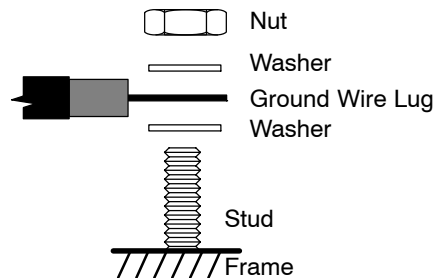

1. Determine ground stud location and connect the ground wire to the “earth ground” terminal shown in Figure 3-7. This ground is the local reference ground to ground the Genset frame only.

## Battery Charger Considerations

1. Mount the battery charger on the Genset or as close to the Genset as possible.
2. If you mount the battery charger inside the building, mount it near the main breaker box or disconnect box.
3. If you mount the battery charger outside, you must protect it from the environment and the elements.
4. Do not mount the battery charger where flammable liquids or vapors are present.

## General Wiring Considerations

1. When routing the interface wiring, do not route it up against anything that could cut or chafe the wiring. do not route the wire up against any hot or potentially hot object.
2. Make sure that all the electrical components (Genset, transfer switch, battery charger, etc.) share a common hard wired ground.
3. Check with your local building inspector to determine what you must do to comply with the local regulations for grounding of this type of permanent installation.

**WARNING: Be sure the system is properly grounded before applying power. Do not apply AC power before you ensure that grounds are connected. Electrical shock can cause serious or fatal injury. NEC requires that the frame and exposed conductive surfaces (metal parts) be connected to an approved earth ground. Local codes may also require proper grounding of Genset.**

---

**Caution:** This Genset must have a battery installed for operation. The battery is used during starting and during operation. If engine operation is attempted while the battery is removed, damage to the engine's electrical components may result.

### **Battery Connections**

**WARNING:** Installation and servicing of batteries is to be performed or supervised by personnel knowledgeable of batteries and the required precautions. Keep unauthorized personnel away from batteries.

**WARNING:** Do not dispose of battery or batteries in a fire. The battery is capable of exploding. If the battery explodes, electrolyte solution will be released in all directions. Battery electrolyte solution is caustic and can cause severe burns and blindness. If electrolyte contacts skin or eyes, immediately flush the area with water and seek medical attention quickly.

**WARNING:** Do not mutilate the battery . The battery contains electrolyte solution which is caustic and can cause severe burns and blindness. If electrolyte contacts skin or eyes, immediately flush the area with water and seek medical attention quickly.

**WARNING:** A battery presents a risk of electrical shock hazard and high short circuit current. The following precautions are to be followed when working on batteries:

1. Remove watches, rings, necklaces and all other metal objects.
2. Use tools with insulated handles.
3. Wear rubber gloves and boots.

**WARNING:** The battery electrolyte is a dilute sulfuric acid that is harmful to the skin and eyes. It is electrically conductive and corrosive. The following precautions are to be followed when working on batteries:

1. Wear full eye protection (safety glasses or goggles) and protective clothing.
2. Where electrolyte contacts the skin, flush the area immediately with water and wash it off using soap and water.
3. Where electrolyte contacts the eyes, immediately flush the eye thoroughly with water and seek medical attention quickly.
4. Spilled electrolyte is to be washed down with an acid neutralizing agent. A common practice is to use a solution of one pound (500 grams) bicarbonate of soda to one gallon (four liters) of water. The bicarbonate solution is to be added until evidence of reaction (foaming) has ceased. The resulting liquid is to be flushed with water and the area dried.

**WARNING:** A battery presents a risk of fire because they generate hydrogen gas. Hydrogen gas is extremely explosive. Never jump start a battery, smoke in the area around the battery or cause any spark to occur in the area around the battery. The following precautions are to be followed when working on batteries:

1. Do not smoke when near batteries.
2. Do not cause flame or spark in battery area.
3. Discharge static electricity from body before touching batteries by first touching a grounded metal surface.

**WARNING:** Disconnect the battery's ground terminal before working in the vicinity of the battery or battery wires. Contact with the battery can result in electrical shock when a tool accidentally touches the positive battery terminal or wire. The risk of such shock is reduced when the ground lead is removed during installation and maintenance.

**Procedure:** The correct type battery must be installed in the battery compartment provided, see Table 3-8. Installation and servicing of batteries is to be performed or supervised by personnel knowledgeable of batteries and the required precautions. Keep unauthorized personnel away from batteries.

1. Open access doors and locate battery tray.
2. Place the correct battery (see Table 3-8) on the tray.
3. **10–25kW ONLY.** Install the Battery Hold Down Bar and Rods as shown in Figure 3-8.
  - a. Place the bent end of the Battery Hold Down Rod through the hole in the Battery Tray.
  - b. Place the threaded end of the Battery Hold Down Rod through the hole in the Battery Hold Down Bar and secure with flat washer, lock washer and nut.
  - c. Repeat steps a and b for the other Battery Hold Down Rod.

**Figure 3-8 Battery Installation (10–25kW only)**

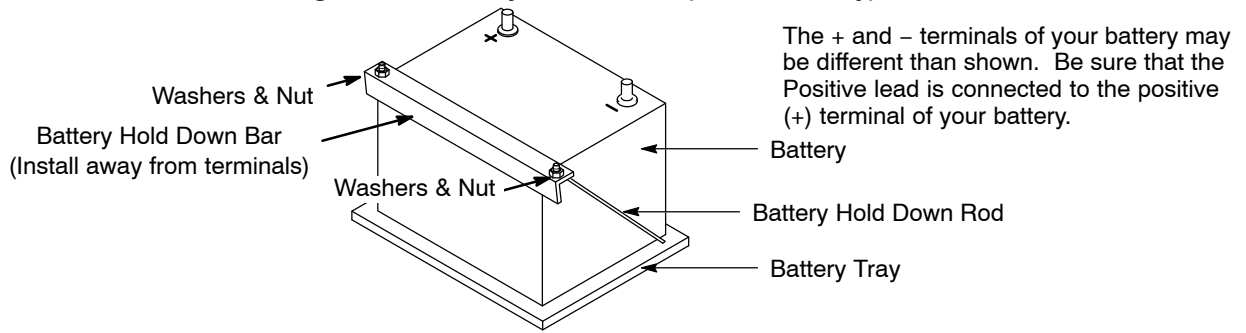

4. Connect the positive lead to the positive (+) battery terminal.
5. Connect the negative lead to the negative (-) battery terminal.
6. Do not lay tools or metal parts on top of batteries.
7. Connect charging source to the battery terminals.
8. Disconnect the battery's ground terminal before working in the vicinity of the battery or battery wires. Contact with the battery can result in electrical shock when a tool accidentally touches the positive battery terminal or wire. The risk of such shock is reduced when the ground lead is removed during installation and maintenance.

**Recommended Engine Coolant**

Refer to the Engine manual for coolant type. Normally a 50/50 mix of coolant and water is required. Coolant system capacity is shown in Table 3-8.

**Recommended Engine Oil and Battery Type**

When replacing batteries, use only the recommended battery for your Genset, see Table 3-8.

**Table 3-8**

MODEL	COOLANT CAPACITY qt (L)	SUMMER OIL	WINTER OIL (less than 0°F)	OIL CAPACITY	RECOMMENDED BATTERY	(AMPS) COLD CRANKING
IGLC25-2G	20.0(18.9)	SAE. 15W40	5W/30	5.0 QTS	BCI Group 24	675
IGLC35-2G	20.0(18.9)	SAE. 15W40	5W/30	5.0 QTS	BCI Group 24	675
IGLC45-2G	20.8(19.7)	SAE. 15W40	5W/30	5.0 QTS	BCI Group 31	925
IGLC55-2G	21.2(20.1)	SAE. 15W40	5W/30	5.0 QTS	BCI Group 31	925
IGLC75-2G	22.0(20.8)	SAE. 15W40	5W/30	5.0 QTS	BCI Group 31	925
IGLC105-2G	27.2(25.7)	SAE. 15W40	5W/30	9.0 QTS	BCI Group 31	925
IGLC130-2G	25.6(24.2)	SAE. 15W40	5W/30	9.0 QTS	BCI Group 31	925

**Post Installation Checks**

When the initial installation is complete, these checks must be performed before starting the engine. These checks are not required before each start, only after the initial installation.

1. Gensets that have been in transit or storage for long periods may be subjected to extreme temperature and moisture changes. This can cause excessive condensation, and the generator windings should be thoroughly dried before bringing the Genset up to full nameplate voltage. If this precaution is not taken, serious damage to the Genset can result.

**Caution: Do not apply high voltage to windings (do not start the Genset) in a moisture-saturated condition. Moisture can cause insulation breakdown, making it necessary to return the Genset for repair.**

Note: These precautions are especially necessary in locations such as seaboard installations and other high humidity areas. Some installations will be in atmospheres that are much more corrosive than others.

2. Verify that the transfer switch is in Utility Power mode. No power must be present at the Genset or transfer switch connections. Verify with a voltmeter.
3. Verify that the engine starting battery is disconnected so accidental starting is not possible.
4. Verify that the Genset is securely mounted and anchored to its cement pad.

---

## **Post Installation Checks** Continued

5. Verify that proper clearance exists on all sides and top of enclosure.
6. Verify that Genset power is properly connected to the transfer switch.
7. Verify that Genset and transfer switch are properly grounded.
8. Assure that Genset is a safe distance from any flammable or combustible material.
9. Verify that the Genset and transfer switch load are voltage compatible.
10. Verify that no load is connected to the circuit breaker and/or transfer switch.
11. Inspect the engine and Genset and verify that there are no loose wires or components. Tighten if necessary.
12. Verify that the ground conductor is of correct wire size and properly connected.
13. Verify engine oil level is full. Refer to engine manual if necessary.
14. Verify engine coolant level is full. Refer to engine manual if necessary.
15. Verify exhaust system to assure it is in properly connected and pointing away from combustible materials.
16. Verify that the Master Control Switch is still in the “Stop” position. Connect the engine starting battery to the starter. Verify it is installed correctly.
17. Verify the fuel select source jumper is set to select operation on the correct fuel type.
18. Verify the fuel source is ON and the pressure and flow rate are correct.
19. Remove all tools, rags, etc. from inside the Genset enclosure. Close all enclosure doors and be sure no hands are inside the Genset enclosure when it starts.
20. Verify all loads are disconnected.
21. Start the Genset. (Refer to Section 4 Operation for details).
22. The engine should begin to crank and start when the fuel moves through the pipe to the carburetor. If the engine fails to start, refer to Section 5 Troubleshooting.
23. With the engine running, several checks must be made:
  - a. Verify there are no fuel leaks. If a fuel leak is detected, stop the engine immediately (move the Master Control Switch to the “Stop” position) and repair the leak before proceeding.
  - b. Verify there are no coolant or oil leaks. If a leak is detected, stop the engine immediately and repair the leak before proceeding.
  - c. Verify that operation is smooth. If belt squeals, vibrations or other sources of noise exist, stop the engine immediately and repair before proceeding.
  - d. Verify that the correct voltage exists (line-to-line and line-to-neutral) at the Genset and at the transfer switch.
  - e. Minor adjustment of the output voltage is made using the “Voltage Adjust” potentiometer on the control panel.

**WARNING: Engine coolant is under pressure and is near the boiling point of water when engine is hot. Do not open the coolant system until the engine has completely cooled. Hot coolant can cause severe burns and other injuries. When engine is cool, coolant level can be checked.**

24. After the operation checks are made, stop the engine (move the Master Control Switch to the “Stop” position) and wait at least 2 hours for the engine to cool. When the engine is cool, check engine oil and coolant levels as instructed in the engine operation manual.
25. Close all enclosure covers. The post installation checks are now complete.

# Section 4 Operation

## Digital Engine Controller Description EM0046A45 (MRS19)

**Figure 4-1 Operator Control Panel**

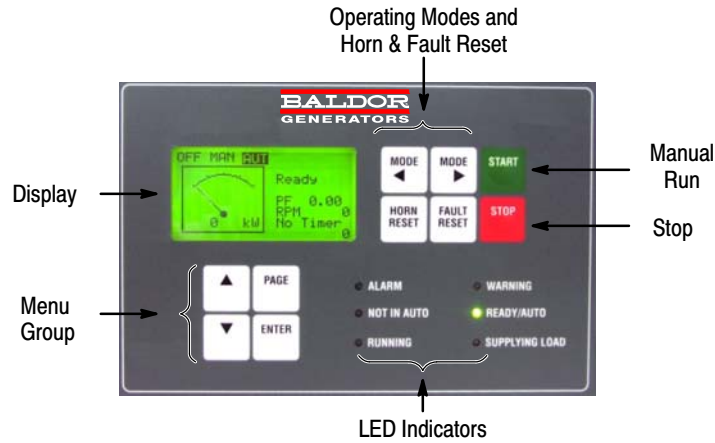

Note: The operator control panel is equipped with a heater element that allows the LCD display to operate to  $-40^{\circ}\text{C}$  (not the entire generator set, see generator specifications). This heater operates from the main battery power.

### LED Indicators

Alarm (red) – Alarm (shutdown) condition occurred. Annunciates & shuts down generator.  
 Not In Auto (red) – Control is not in auto mode and cannot provide standby power.  
 Running (green) – Generator is running, no alarms or warnings.  
 Warning (yellow) – A warning condition has occurred. Annunciates only.  
 Ready/Auto (green) – Control is in Auto mode and ready to provide standby power.  
 Supplying Load (green) – Generator is providing output voltage to load.

**Table 4-1 Alarm & Warning Conditions**

Alarm	Warning	
X	X	High Coolant temperature
X	X	Low Oil pressure
X	X	Generator Under/Over Voltage
X	X	Generator Under/Over Frequency
X	X	Generator Over Current
X		Generator Overspeed
	X	Coolant temperature Low
	X	Starting battery Under/Over Voltage

### Manual Run

Immediately begins the crank cycle to start engine and produce power (MAN mode only).

### Start

Start generator set operation (MAN mode only).

### Stop

Stops the Engine and generator set (MAN mode only).

### Display

Displays setpoints, adjustments, Alarms and Warning conditions and Operating Mode selections.

### Page

Changes menu displayed – Measurement, Adjustment or History.

### Mode ◀ and ▶

Allows selection of OFF – MAN – AUTO mode choices.

### Horn Reset

Deactivates the Horn output.

### Fault Reset

Reset Alarms and Warnings.

### ▲ and ▼

Selects the menu choice, select the setpoint or select the menu or increase/decrease the setpoint value.

### Enter

Confirm and accept changed setpoint value.

Enter + ▲ and ▼ Adjusts display contrast.

Enter+ Fault Reset Clears engine ECU faults.

## Digital Engine Controller Description EM0046A45 (MRS19) Continued

**Operating Mode** Press Mode ◀ or ▶ to scroll through the list of operating modes: Off, Manual and Automatic. The control mode is shown in the highlighted area at the top of the display, Figure 4-2. When the desired Control Mode is highlighted, press Start to begin operation. Press Stop to terminate operation.

OFF – Generator set operation is not allowed.  
MAN – Press Start to manually start the generator set immediately.  
Press Stop to stop the generator set immediately.  
AUT – Start and Stop buttons are ignored.  
The binary input terminal conditions start and stop the generator set.

### Display Menus

Three display menus are available: Measurement, Adjustment and history. Press the Page button repeatedly to display each menu. Use ▲ ▼ and Enter keys to change and accept setpoint values or press the Page button to cancel changes.



### Measurement Menu

The measurement menu, shown in Figure 4-2 displays the operating mode, and operating parameters such as kW, engine RPM etc.

**Figure 4-2 Measurement Menu**

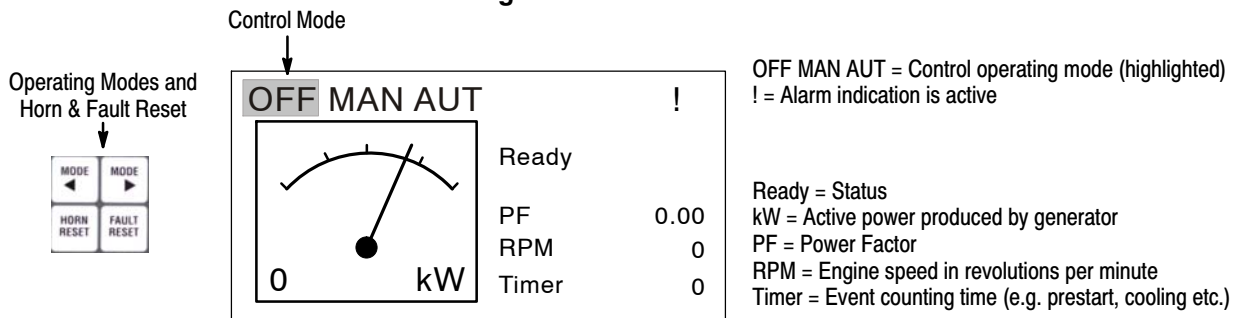

### OFF Mode

Starting of the generator set is not possible. Outputs STARTER (BO1) and FUEL SOLENOID (BO2) are not active. No action if buttons START and STOP are pressed.

### MAN Mode

START button starts the generator set.

STOP stops the generator set.

This operation is further defined in Table 4-2.

### AUT Mode

No action if Start button is pressed. The controller can be programmed so the Stop Button is either active or inactive when controller is in the AUT mode.

Engine Start/Stop request is given by binary input REM Start/Stop (B11).



**Table 4-2 Manual Mode Sequence Description**

Menu	Status	Condition of Transition	Action <sup>1</sup>	Next State	
Main Measurement	Ready	Start request	PRESTART on, Prestart time counter started	PRESTART	
		RPM > 2 or Oil pressure detected or Gen voltage > 10V		Stop (Stop fail)	
		OFF mode selected or Shut down alarm active		Not Ready	
	Not Ready	RPM < 2, Oil pressure not detected, Vgen < 10V, no shutdown alarm active, other than OFF mode selected			Ready
	Prestart	Prestart time elapsed	STARTER on, FUEL SOLENOID on, MaxCrank time counter started		Cranking
	Cranking	RPM > Start RPM	STARTER off, PRESTART off		Starting
		D+ input activated or oil pressure detected or Gen voltage > 25% Vgnom	STARTER off, PRESTART off		Cranking
		MaxCrank time elapsed, 1st attempt	STARTER off, FUEL SOLENOID off, STOP SOLENOID on, CrankFail pause timer started		Crank pause
		MaxCrank time elapsed, last attempt	STARTER off, PRESTART off		Shutdown (Start fail)
	Crank Pause	CrankFail pause elapsed	STARTER on, FUEL SOLENOID on, STOP SOLENOID off, MaxCrank time counter started		Cranking
	Starting	30% Nominal speed reached	READY TO LOAD on, MaxStabTime counter started		Running
	Running	Stop request	READY TO LOAD off, Cooling time timer started		Cooling
		RPM = 0 or any other shutdown condition	READY TO LOAD off, FUEL SOLENOID off		Shutdown
	Loaded	RPM = 0 or any other shutdown condition	FUEL SOLENOID off, STOP SOLENOID on, READY TO LOAD off		Shutdown
	Cooling	Cooling time elapsed	FUEL SOLENOID off, STOP SOLENOID on		Stop
		RPM = 0 or any other shutdown condition	FUEL SOLENOID off, STOP SOLENOID on		Shutdown
		Start request	READY TO LOAD on		Running
	Stop	RPM = 0, Oil pressure not detected, Vgen < 10V			Ready
		60 sec. Elapsed			Stop (Stop fail)

<sup>1</sup> Some output conditions are optional and may require additional programming of field connection. See appropriate wiring diagram.

**Adjustment Menu**

The adjustment menu, Figure 4-3 allows setting engine and generator values such as Passwords, Pre-Start Time, Crank Time, Cool Down Time, Alarm Conditions and values, Shutdown Conditions and values, power transfer settings, etc.

**Figure 4-3 Adjustment Menu**

> ENGINE BASIC ENGINE PROT GEN BASIC GEN PROTECT
---

Use ▲ and ▼ to move the cursor to the desired parameter.  
 Press ENTER to select the parameter group.  
 Press PAGE to move to the next page of menu items.

**Alarm List**

Shows the active alarms and warnings. Press fault reset to clear the list.

**ECU Alarm List**

Shows the active ECU (engine control unit) fault codes. Press ENTER + fault reset to clear the list.

---

## Alarms

Following alarms are available:

### Sensor fail (FLS) see Table 4-3

Sensor fail is detected when measured value is 6% out of selected sensor characteristic.

Sensor fail is indicated by ##### symbol instead measured value.

### Warning (WRN) see Table 4-3

When warning comes up, only alarm outputs and common warning output are closed.

### Shut down (SD) see Table 4-3

When the shut-down alarm comes up, IntelliLite opens outputs GCB CLOSE/OPEN, FUEL SOLENOID, STARTER and PRESTART to stop the engine immediately. Alarm outputs and common shutdown output are closed. Active or not reset protection disables start.

**Table 4-3 Possible Warnings**

Events specification	Protection type
Wrn Oil press	WRN
Sd Oil press	SD
Wrn Water temp	WRN
Sd Water temp	SD
Wrn Wtemp Low	WRN
Battery voltage <, >	WRN
Battery flat	SD
Start fail	SD
Vgen <, >	SD
Vgen unbl	SD
Fgen <, >	SD
Igen unbl	SD
Overload	SD
RPM over	SD
RPM under	SD
PickupFault	SD
Stop fail	SD
WrnServiceTime	WRN
Emergency Stop	SD
ECU Common Warning	WRN
ECU Shutdown	SD

---

## **Inputs and Outputs**

Any Binary input or output can be configured to any controller terminal (Inputs are BI1 – BI7, Outputs are BO1 – BO7) or changed to different function by LiteEdit software. There is fixed 1 sec delay when any binary input is configured as protection.

**Table 4-4 Binary Inputs**

Alarm	Alarm type Warning or Shut down Alarm active All the time, or Engine running only
Rem start/stop	External request for engine run. AUT mode only.
Emergency stop	If the input is opened, shut down is immediately activated. Input is inverted (normally closed).
Rem start/stop	External request for engine run. AUT mode only.

**Table 4-5 Binary outputs**

Starter (relay output)	The closed relay energizes the starter motor. The relay opens if: <ul style="list-style-type: none"><li>• The firing speed is reached or</li><li>• Maximum time of cranking is exceeded or</li><li>• Request to stop occurs</li></ul>
Fuel solenoid (relay output)	Closed output opens the fuel solenoid and enables the engine start. The output opens if: Emergency stop occurs or Cooled gen-set is stopped or In pause between repeated starts
Prestart	Output is closed prior to the engine start (Prestart) and opens when START RPM speed is reached. During repeated crank attempts the output is closed too. The output could be used for pre-glow, pre-heat or prelubrication.
Common Sd	Output closes when any shut-down alarm appears. The output opens, if alarm is not active and FAULT RESET is pressed. Used for shunt trip.

## Analog Inputs

Three analog inputs for resistive sensor 0 to 2400 ohms measuring are available on the controller. Use LiteEdit software to modify configuration. The Analog inputs values assignment (AI1 = Oil press, AI2 = Water temp, AI3 = Fuel level) is fixed. It is possible to configure on each Analog input:

- Reading from Analog inputs or from Engine Control Unit via CAN bus (J1939)
- Sensor characteristics – from the list,
- Value dimension (e.g. psi – bars, °F – °C, % – l)
- Number of decimal points (0, 1, 2, ...).

Note: Corresponding Analog input terminal is dead when reading is switched to ECU. All values from ECU shall show #####, but no alarm is displayed when CAN communication is interrupted.

Warning and shut-down limits are adjusted in Engine protection group.

**Table 4-6 Analog Inputs**

AI1 Oil press	Oil pressure analog input. Default VDO sensor in range 0 to 145 psi.
AI2 Water temp	Water temperature analog input. Default VDO sensor in range 32 to 212°F
AI3 Fuel level	Fuel level analog input. Default VDO sensor 0–180R = 0–100%.

## Set points

**Table 4-7 Basic Setpoints**

EnterPassword	Password is a four-digit number. Password enables change of relevant protected set points Use ↑ or ↓ keys to set and ENTER key to enter the password.
ChangePassword	Use ↑ or ↓ keys to set and ENTER key to change the password.
Gen-set name	User defined name, used for identification at remote phone or mobile connection. Gen-set name is max 14 characters long and have to be entered using LiteEdit software.
Nomin power(3ph)	Nominal power of the generator in three phases connection. Step: 1 kW; Range: 1 – 3000 kW
Nomin power(1ph)	Nominal power of the generator in single-phase connection. Step: 1 kW; Range: 1 – 3000 kW
CT Ratio	Gen-set phases current transformers ratio. Step: 1 A; Range: 1 – 5000 A / 5A
PT ratio	Gen-set potential transformers ratio. Step: 0,1 V / V; Range: 0,1 – 500,0 V / V
Nominal freq	Nominal generator frequency (usually 50 or 60 Hz ) Step: 1Hz; Range: 45 – 65 Hz
Gear teeth	Number of teeth on the engine gear for the pick-up. Set to zero, if no pick-up is used. Engine speed is counted from the generator frequency. Step: 1; Range: 0 – 500 Note: Generator frequency can be used only when generator voltage (min 5V) is present before reaching of the firing speed (Starting RPM) after start.
Nominal RPM	Nominal engine speed. Step: 1RPM; Range: 100 – 4000 RPM.
FLTRESGOTOMAN	DISABLED: Controller stays in AUT mode after Fault reset . ENABLED: Automatic switch from AUT (or TEST) to MAN mode after Fault reset to avoid automatic engine start. This function is active for Shut down protection only.
DispBackLightTO	Timeout after which the display backlight is switched off. Step: 1 min Range: 0 – 60 min Default value: 0 = the display lights all the time
Mode IL [ OFF, MAN, AUT ]	Equivalent to Controller mode changes by MODE▶ or MODE◀ buttons. Note: Controller Mode change can be separately password protected.
RS232 mode [Standard/Modbus ]	Communication protocol switch. Standard: LiteEdit communication protocol. Modbus: Modbus protocol. Note: For detail description see chapter Modbus protocol.
Num rings AA	Number of rings prior to open modem connection. Step: 1; Range: 1 – 30 Note: NumberRings AA change is not activated immediately. It is activated after controller is switched on or when modem is connected to controller.

**Table 4-8 Engine Setpoints**

Start RPM	"Firing" speed when iL controller stops cranking (starter goes OFF). Step: 1% of nominal RPM; Range: 5 – 50 %
Starting POil	When reached controller stops cranking (starter goes OFF). Step: 0,1 psi; Range: –100 – 10000 Note: There are three conditions for stop cranking: Starting RPM, StartingPOil and D+ (when enabled). Starter goes off when any of these conditions is valid.
Prestart time	Time of closing of the PRE–START output prior to the engine start. Set to zero if you want to leave the output PRE–START open. Step: 1s; Range: 0 – 600 s
MaxCrank time	Maximum time limit of cranking. Step: 1s; Range: 1 – 60 s
CrnkFail pause	Pause between crank attempts. Step: 1s; Range: 5 – 60 s
Crank attempts	Max number of crank attempts. Step: 1; Range: 1 – 10
Idle time	Idle time delay starts when RPM exceeds Start RPM . Start fail is detected when during Idle state RPM decreases below 2. During the Idle time timer running the binary output IDLE/NOMINAL is opened, when it elapses the IDLE/NOMINAL output closes. Binary output IDLE/NOMINAL opens during Cooling period again. Step: 1 s; Range: 0 – 600 s Note: If the IDLE function not supported on the governor, set the Idle time nevertheless to minimum 5s to avoid Underspeed possibly caused by instability of the engine short after start.
GCB CloseDelay	GCB can be closed earliest GCB CloseDelay after Stabil time when all electric values are in overunder voltage and over–under frequency limits. Step: 1 s; Range: 0 – 300 s
Stabil time	Generator Nominal voltage is detected during genset start after starter is switched off and Idle time elapses. Electric generator protections are active since detection. Step: 1 s; Range: 0 – 300 s
MinStpValvTime	Binary output Stop solenoid closes when stop sequence begins and closes at least for MinStpValvTime. Example MinStpValvTime = 20 sec. a) When engine stops (RPM=0) in 10 seconds, Binary output Stop solenoid still stays closed for 10 sec. b) When engine stops in 30 seconds, Binary output Stop solenoid opens 10 seconds after RPM=0 and Vg =0 and Oil pressure = 0. Those 10 sec is fix time for safe stop. Step: 1s; Range: 0 – 180 s Note: Stop of engine is detected when all following conditions are met: RPM =0, Oil pressure < StartingPOil and Generator voltage < 10 VAC. Stop fail is detected when is difference between those conditions, e.g RPM=O and Generator voltage > 10V.

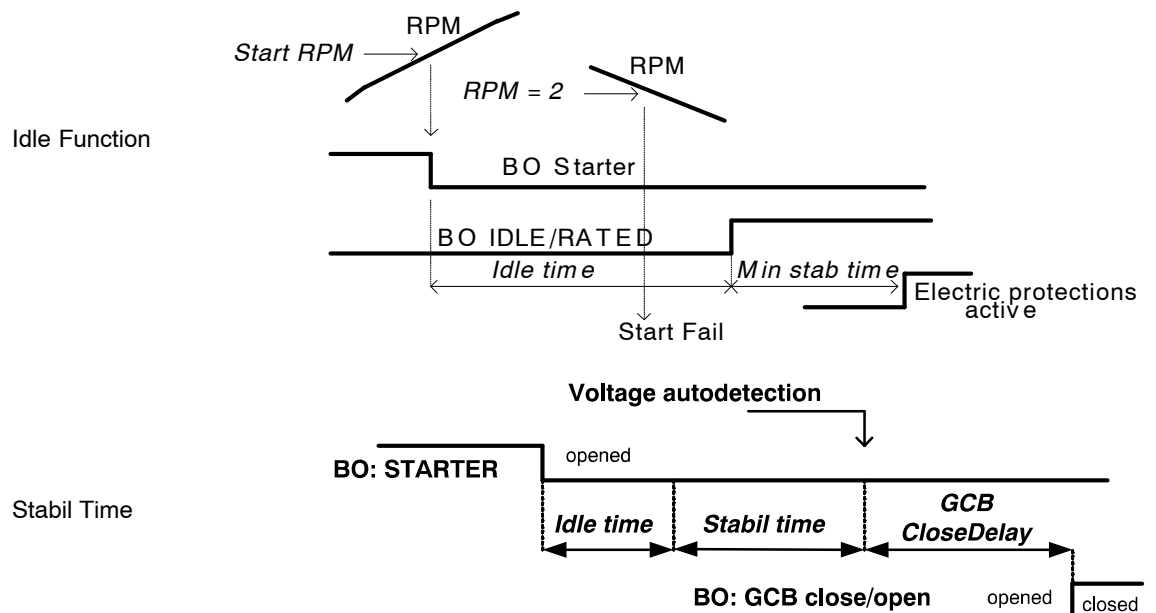

**Table 4-8 Engine Setpoints** Continued

Cooling time	Runtime of the unloaded gen-set to cool the engine before stop. Step: 1s; Range: 0 – 3600 s
AfterCoolTime	Runtime of engine after cooling pump. Binary output Cooling pump is closed when the engine starts and opens AfterCool time delayed after gen-set stops. Step: 1s Range: 0 – 3600s
CoolingSpeed	Selects the function of the Binary output IDLE/NOMINAL during engine Cooling state. NOMINAL : Cooling is executed at Nominal speed and generator protections are active. IDLE: Cooling is executed at Idle speed and generator protections are switched off. Hint: Binary output IDLE/NOMINAL must be configured and connected to speed governor. Engine Idle speed must be adjusted on speed governor.
D+ function	ENABLED: The D+ terminal is used for both functions “running engine” detection and charge fail detection. CHRGFAIL: The D+ terminal is used for charge fail detection only DISABLED: The D+ terminal is not used. Note: Magnetization current is independent of this setpoint value.

**Table 4-9 Engine Protect Setpoints**

ECUFreqSelect	This setpoint should be used only for Volvo and Scania engines.
ECU Speed Adjust	Adjusts engine speed using CAN bus. Nominal speed=50%.
WTBF Accept RPM	The WtBfAcceptRPM delay setpoint will start to count down since cranking. Controller waits before communicating with the ECU for this time. This is because the JD engine passes some erroneous RPM signals during the first 500ms. Step: 0,1s Range: 0 – 3s
Eng prot del	During the start of the gen-set, some engine protections have to be blocked (e.g. Oil pressure). The protections are unblocked after the Protection del time. The time starts after reaching Start RPM. Step: 1s; Range: 0 – 300 s
Horn timeout	Max time limit of horn sounding. Set to zero if you want to leave the output HORN open. Step: 1s; Range: 0 – 600 s
Overspeed	Threshold for over speed protection. Step: 1% of nominal RPM; Range: 100 – 150%
Wrn Oil press	Warning threshold level for ANALOG INPUT 1. Step: 1 psi; Range: Sd Oil press – 10000
Sd Oil press	Shutdown threshold level for ANALOG INPUT 1. Step: 1 psi; Range: –100 – Wrn Oil press
Oil press del	Delay for ANALOG INPUT 1. Step: 1 s; Range: 0 – 180
Sd Water temp	Warning threshold level for ANALOG INPUT 2. Step: 1 °C; Range: Wrn Wtemp – 10000
Wrn Water temp	Warning threshold level for ANALOG INPUT 2. Step: 1 °F; Range: Wrn Wtemp low – Sd Water temp
Wrn Wtemp low	Warning threshold level for low value on ANALOG INPUT 2. Step: 1 °F; Range: –100 – Wrn Water temp
Water temp Low del	Delay for ANALOG INPUT 2 Wrn Wtemp low. Step: 1 s; Range: 1–180 s
Water temp del	Delay for ANALOG INPUT 2 alarm. Step: 1 s; Range: 0 – 180 s
Batt overvolt	Warning threshold for high battery voltage. Step: 0,1 V; Range: Batt undervolt – 40V
Batt undervolt	Warning threshold for low battery voltage. Step: 0,1 V; Range: 8V – Batt overvolt
Batt volt del	Delay for low battery voltage alarm. Step: 1s; Range: 0 – 600 s
NextServTime	Counts down when engine running. If reaches zero, an alarm appears. Step: 1h; Range: 0 –65535h

**Table 4-10 Generator Protect Setpoints**

Overload	Threshold for generator overload (in % of Nominal power) Step: 1% of Nominal power; Range: 0 – 200%
Overload Wrn	Threshold for generator overload warning (in % of Nominal power) Step: 1% of Nominal power; Range: 0 – 200%
Overload del	Delay for generator overload alarm. Step: 0.1s; Range: 0 – 60.0 s
Ishort	Shutdown occurs when short circuit limit Ishort limit is reached. Step: 1 % of Nominal current; Range: 100 – 500 %
2Inom del	IDMT curve shape selection. 2Inom del is Reaction time of IDMT protection for 200% overcurrent Igen = 2* Nominal current. Step: 0,1 s; Range: 0,1 – 20 s IDMT is “very inverse” generator over current protection. Reaction time is not constant but depends on generator over current level according following formula. Reaction time is limited up to 900 sec = 15 minutes. IDMT protection is not active for Reaction time values longer than 15 minutes. $\text{Reaction Time} = \frac{2\text{Inom del} * \text{Nomin current}}{\text{Igen} - \text{Nomin current}}$
Curr unbal	Threshold for generator current asymmetry (unbalance). Step: 1% of Nominal current; Range: 1 – 100% of Nominal current
Curr unbal del	Delay for generator current asymmetry. Step: 0.1 s; Range: 0 – 60.0 s
Gen >V	Shutdown level for generator overvoltage. All three phases are checked. Maximum out of three is used. Step: 1% of Nominal voltage; Range: Gen >V Wrn –200%
Gen >V Wrn	Warning level for generator overvoltage. All three phases are checked. Maximum out of three is used. Step: 1% of Nominal voltage; Range: Gen <V Wrn – Gen >V
Gen <V Wrn	Warning level for generator under voltage. All three phases are checked. Minimum out of three is used. Step: 1% of Nominal voltage; Range: Gen <V – Gen >V Wrn
Gen <V	Shutdown level for generator under voltage. All three phases are checked. Minimum out of three is used. Step: 1% of Nominal voltage; Range: 0% – Gen <V Wrn
Gen V del	Delay for generator under voltage and over voltage alarm Step: 0.1s; Range: 0 – 60 s
Volt unbal	Threshold for generator voltage unbalance alarm. Step: 1% of Nominal voltage; Range: 0 – 100% of Nominal voltage
Volt unbal del	Delay for generator voltage unbalance alarm. Step: 0.1s; Range: 0 – 60.0 s
Gen >f	Shutdown level for generator over frequency. Step: 0.1% of Nominal frequency; Range: Gen > Wrn – 200.0%
Gen >f Wrn	Warning level for generator over frequency. Step: 0.1% of Nominal frequency; Range: Gen <f Wrn – Gen >V
Gen <f	Shutdown level for generator under frequency. Step: 0.1% of Nominal frequency; Range: 0.0 – Gen <f Wrn
Gen <f Wrn	Warning level for generator under frequency. Step: 0.1% of Nominal frequency; Range: Gen <f – Gen >f Wrn
Gen f del	Delay for generator under frequency and over frequency alarm. Step: 0.1s; Range: 0 – 60.0 s

**Table 4-11 Sensor Spec Setpoints**

Calibr AI1,AI2, AI3	Calibrating constant to adjust the measured value of IL analog inputs. Physical dimension of calibrating constant is corresponding to Analog input. Step: 1; Range: -1000 to +1000
AnOut-kW/20mA	Conversion coefficient from gen-set power to iG-IOM or PTM analog output. Step: 1; Range: 1 to 32000

**Table 4-12 IOM/PTM Module Setpoints**

AnIInIOM1 lev1	The level for IOM ANALOG INPUT 1 alarm detection. Step: 1; Range: -100 to +10000
AnIInIOM1 lev2	The level for IOM ANALOG INPUT 1 alarm detection. Step: 1; Range: -100 to +10000
AnIInIOM1 del	Delay for IOM ANALOG INPUT 1 alarm. Step: 1 s; Range: 0 - 180 s
AnIInIOM2 lev1	The level for IOM ANALOG INPUT 2 alarm detection. Step: 1; Range: -100 to +10000
AnIInIOM2 lev2	The level for IOM ANALOG INPUT 2 alarm detection. Step: 1; Range: -100 to +10000
AnIInIOM2 del	Delay for IOM ANALOG INPUT 2 alarm. Step: 1 s; Range: 0 - 180 s
AnIInIOM3 lev1	The level for IOM ANALOG INPUT 3 alarm detection. Step: 1; Range: -100 to +10000
AnIInIOM3 lev2	The level for IOM ANALOG INPUT 3 alarm detection. Step: 1; Range: -100 to +10000
AnIInIOM3 del	Delay for IOM ANALOG INPUT 3 alarm. Step: 1 s; Range: 0 - 180 s
AnIInIOM4 lev1	The level for IOM ANALOG INPUT 4 alarm detection. Step: 1; Range: -100 to +10000
AnIInIOM4 lev2	The level for IOM ANALOG INPUT 4 alarm detection. Step: 1; Range: -100 to +10000
AnIInIOM4 del	Delay for IOM ANALOG INPUT 4 alarm. Step: 1 s; Range: 0 - 180 s
Calibr AIiIOM 1..4	The protection of IOM/PTM inputs is activated by over crossing the limits. Calibrating constant to adjust the measured value of IOM/PTM analog inputs. Physical dimension of calibrating constant is corresponding to Analog input. Step: 1; Range: -1000 to +1000



Figure 4-4 Controller Connection Diagram

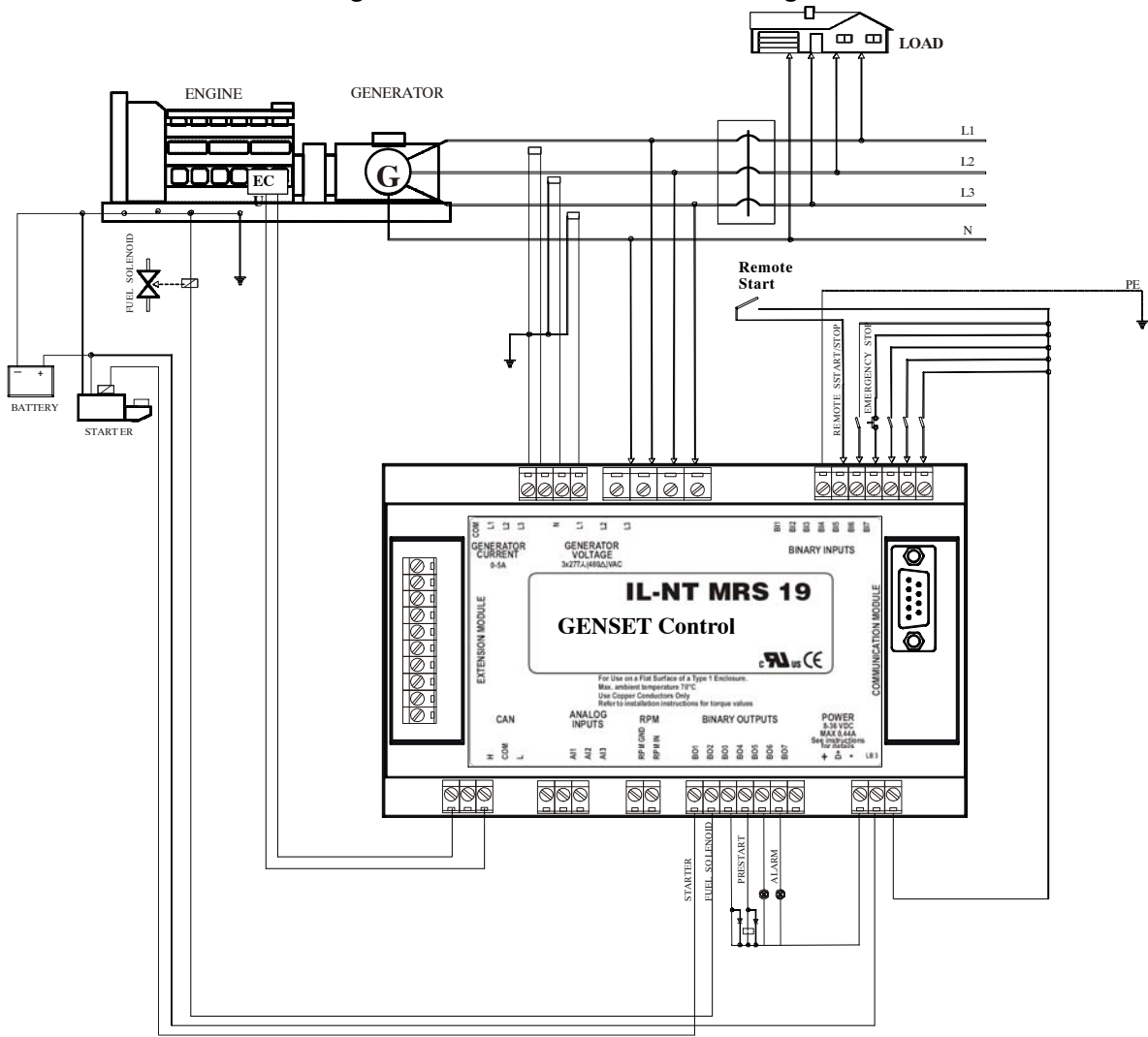



## Section 5

# Troubleshooting and Maintenance

---

### **Maintenance**

This manual contains only very minimal engine maintenance instructions. Refer to the engine manufacturer's owner's manual for specific engine maintenance instructions for your generator set. Any maintenance instructions or recommendations in the engine owner's manual take precedence over any of the following general recommendations.

#### **General:**

1. Inspect the fuel system for leaks. Replace all defective components immediately.
2. Inspect and replace any fuel line that shows signs of deterioration.
3. Inspect all the fuel clamps to ensure they are tight.
4. Inspect and clean the battery posts and the associated battery cable terminals.
5. Inspect the external wire cables and connectors used with the generator set for cuts, fraying, or loose connections. Repair or replace any problems prior to using the unit.

#### **Engine:**

1. Clean and/or replace any fuel, oil, and/or air filters per the engine manufacturers' guidelines.
2. Check oil level regularly; at least every 5 to 8 operating hours. Maintain the proper oil level.
3. Change the oil as is recommended in the engine manufacturer's owner's manual.
4. Replace the spark plug(s) as is recommended by the engine manufacturer.

#### **Alternator:** ( also called Generator End)

This generator set must be run at its proper speed to obtain the correct electrical power at its output. All engines have a tendency to slow down when a load is applied to it. The engine governor is designed to hold the operating speed as nearly constant as possible. When the electrical load is increased, the engine is more heavily loaded and engine speed drops slightly. This slight decrease in engine speed results in a slight decrease in generator voltage and frequency output. This voltage and frequency variation has no appreciable effect in the operation of motors, lights, and most appliances and tools. However, timing devices and clocks may not keep perfect time when powered by a generator.

1. Clean the generator set and remove any and all dust, dirt, or other foreign material.
2. Inspect and clean the cooling air intake and exhaust louvers of the generator end. Make sure they are clean. Remove dirt or any buildup that may restrict the cooling air flow.
3. Clean the generator set and its components with a damp cloth or sponge. Never use a water hose or pressure washer as this may damage electrical components.
4. Inspect and replace any control panel components that are broken or not working properly (receptacles, circuit breakers, switches, etc.)

## Problems and Solutions

Some of the more common problems are listed in Table 5-1. This information is intended to be a check or verification that simple causes can be located and fixed. It is not an exhaustive “how to” for all types of problems. Procedures that require in depth knowledge or skills (like flashing the field) should be referred to a qualified generator service center.

**Table 5-1 General Troubleshooting Guide**

<b>Problem</b>	<b>Possible Cause</b>	<b>Remedy</b>
Engine cranks but will not start	No fuel. Low Oil Level Restricted air flow. No spark.	Check that fuel valves are ON. Check fuel level in fuel tank. Low Oil Pressure Shutdown activated. Replenish oil to full. Check/replace air filter. Check/replace spark plug(s). Check that engine switch is in Start position.
Engine will not crank (electric start)	Dead battery.  Emergency Stop LED is ON	Remove battery and trickle charge or replace with new battery. Never Jump Start. Reset controller after an Emergency Stop.
Engine starts but will not run smoothly	Fuel or ignition problem	Refer to engine manual. Verify fuel selection jumper setting.
Engine overheats	Excessive load Debris or dirt buildup on engine	Remove one or more electrical loads. Remove debris. Clean engine surfaces to allow cooling.
No output voltage	Circuit Breaker tripped or failed. Internal failure of Alternator	Reset circuit breaker or replace if required. Contact service.
Output voltage varies	Irregular speed (fixed speed mode) Fluctuating speed (fixed speed mode)  Loose terminal or load connections	Check engine for malfunction or load for fluctuation Stabilize load. The addition of a lamp load (resistance load) may compensate partially for load changes caused by intermittent motor operation. Do not overload. Verify all connections and terminal tightness.
Low output voltage	Low engine speed Excessive load High resistance connections – connections will be warm or hot Internal failure of Alternator Low power factor	Verify engine RPM. Check engine for malfunction or system for overload. Reduce load. Verify all connections and terminal tightness.  Contact service. Reduce inductive (motor) load. Some AC motors use about the same current regardless of load. Do not use motors of greater horsepower rating than is necessary to move the mechanical load.
High output voltage	Excessive speed (fixed speed mode)	Check engine for malfunction. Verify engine RPM.
Electrical shock when frame is touched	Static charge. Grounded armature or field coil.	Ground generator frame at local reference ground (see Section 3). Contact service.
Mechanical noise	Internal failure of Alternator Loose or misaligned coupling	Contact service. Tighten; align coupling and alternator shaft to engine shaft.

**Table 5-2 Troubleshooting Guide (Digital Controller Only)**

<b>Problem</b>	<b>Possible Cause</b>	<b>Remedy</b>
Controller does not power up even with correct DC power applied	Wiring Mistake Overload Condition	Check that there are no wiring errors/short circuits connected to the controller. Check breaker on the Control Panel. Check Fuses on Control Panel.
LCD Display cannot be viewed	Improper Supply Voltage Improper contrast adjustment	Check DC supply voltage at terminals B+ & B- (10–30VDC). Adjust LCD contrast for best display (see Section 4).
Controller cannot be “Reset”	Engine not stopped Controller not in OFF mode	Verify the engine is at a complete stop before trying to reset. Set the controller to the OFF mode before trying to reset.
No “RUN” output signal	“Shutdown Faults” not reset Engine speed not detected at cranking	All shutdown faults must be reset (red shutdown LED must be off). Engine speed signal must be detected (speed signal green LED on) during cranking if the “run-output fail safe” feature is enabled. Verify correct magnetic pickup signal at cranking (2.0VAC min. during cranking).
Overspeed shutdown occurs at normal speed	Controller programmed values are wrong or controller has failed.	Verify the controller programmed values are correct for the number of flywheel teeth, nominal RPM, and overspeed setpoint percentage. Replace controller if failed.
Voltage or current metering is incorrect	Controller programmed values are wrong Ground is missing Analog input needs to be calibrated Voltage sensing wiring mistake	Verify the controller programmed values are correct for the voltage sensing PT ratio and/or current sensing CT ratio. Verify that the battery supply DC negative conductor is properly grounded to the engine block (i.e. to a common ground point). Verify that the controller’s analog input is properly calibrated. Verify the voltage sensing wiring connection to the controller matches power distribution type. Note: standard direct voltage connection requires that the generators neutral is solidly grounded.
Engine temperature or oil pressure display is incorrect	Analog input needs to be calibrated Failed engine sensor Ground is missing	Verify that the controller’s analog input is properly calibrated. Verify engine sensors. Note: engine sensors must be factory supplied units only. Verify that the battery supply DC negative conductor is properly grounded to the engine block (i.e. to a common ground point).
Engine temperature or oil pressure displays 9999 <b>OR</b> Engine alarms are ON for high engine temperature or low oil pressure when engine is operating properly	Sending unit is disconnected (open circuit) Defective sending unit Wrong Temp or pressure calibration	Verify the sending units wiring to controller terminals AI1 and AI2 (i.e. wiring is not open or shorted). Verify the engine mounted senders have correct resistance values for corresponding input temperature or pressure. Verify calibration.
Keypad Buttons (switches) do not operate.	Keypad not connected to controller	Verify the interconnecting ribbon cable between the lexan faceplate and main printed circuit board is correctly connected. Replace controller if failed.

---

Note: See Engine Controller manual for additional information.

**Table 5-3 Troubleshooting Guide (Analog Controller Only)**

<b>Problem</b>	<b>Possible Cause</b>	<b>Remedy</b>
Controller cannot be "Reset"	Engine not stopped Controller not in OFF mode	Verify the engine is at a complete stop before trying to reset. Set the controller to the OFF mode before trying to reset.
Engine alarms are ON for high engine temperature or low oil pressure when engine is operating properly	Sending unit is disconnected (open circuit) Defective sending unit	Verify the sending units wiring to controller terminals is not open or shorted. Verify the engine mounted senders have correct resistance values for corresponding input temperature or pressure.
Overspeed shutdown occurs at normal speed	Controller has failed or input from Magnetic pickup is incorrect.	Verify the adjustments. Replace controller if failed.

**Service**

Service for your generator can be obtained from to a qualified generator service center. Please have the following information available and ready:  
The model number and serial number of the generator set.  
A complete and accurate description of the problem.

**Parts**

Parts for your generator can be obtained from to a qualified generator service center. Please have the following information available and ready:  
The model number and serial number of the generator set.  
A complete and accurate description of the part (part number if known).  
Note: Engine parts can usually be obtained from a local distributor by using the information in the engine manufacturer's owner's manual.

## Appendix A Options & Accessories

---

**Battery Charger** BTCGR10A Battery Charger – 12 Volt /10 Amp Float. Includes terminal strip for AC input power and DC output. UL Listed.

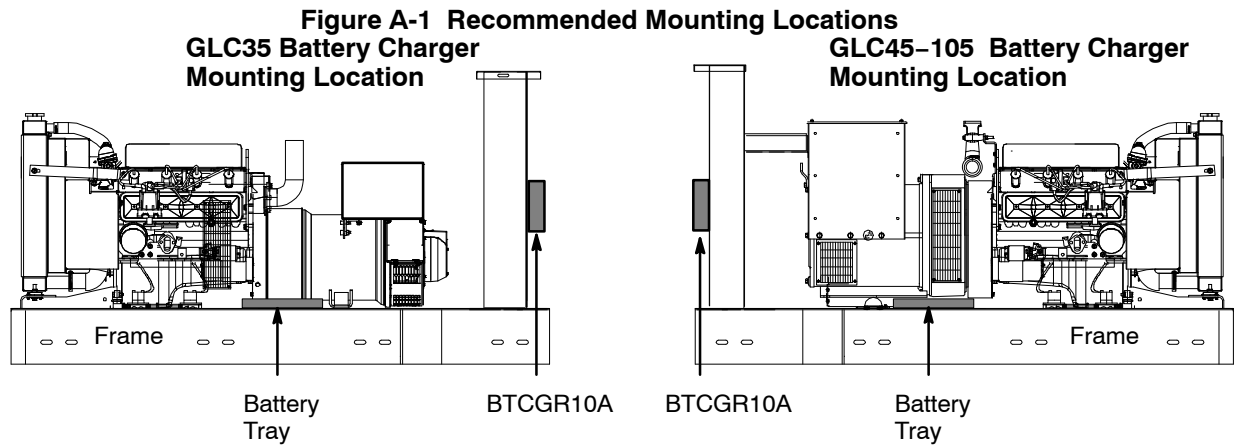

### Installation Considerations:

Shore power must be available (120VAC or 240VAC) to power the battery charger and other components that may be installed). Shore power outlets or wiring must be located close to Battery Charger.

### **BTCGR10A Charger** (refer to charger manual for specific details)

1. Mount charger, refer to Figure A-1 to determine suggested location.
2. Connect charger negative wire (Black) to battery “-” negative terminal.
3. Connect charger positive wire (Red) to battery “+” positive terminal.
4. Connect charger AC power cord to shore power outlet.

**Battery Heaters** Battery Heater (BTHTR81) – 120 Volt / 80 Watt. Includes 6 ft power cord.

**Installation Considerations:**

Shore power must be available (120VAC or 240VAC) to power the battery heater and other components that may be installed). Shore power outlets or wiring must be located close to battery heater.

**Figure A-2 Battery Heating Pad Installation**

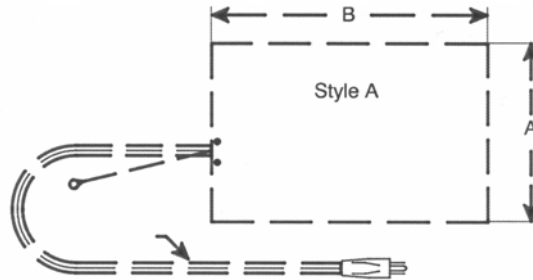

**BTHTR81 Heater**

1. Carefully disconnect the Negative battery terminal from the battery.
2. Carefully disconnect the Positive battery terminal from the battery.
3. Remove battery hold down bracket.
4. Remove battery.
5. Install Heating Pad in battery tray, refer to Figure A-2. The "A" and "B" dimensions should match the battery tray.
6. Install battery on top of Heating Pad.
7. Install battery hold down bracket.
8. Carefully install the Positive battery terminal to the battery.
9. Carefully install the Negative battery terminal to the battery.
10. Connect the AC power cord to shore power outlet.

**Engine Block Heater**

**Installation Considerations:**

Shore power must be available (120VAC or 240VAC) to power the block heater and other components that may be installed). Shore power or wiring must be located close to block heater.

**Figure A-3**

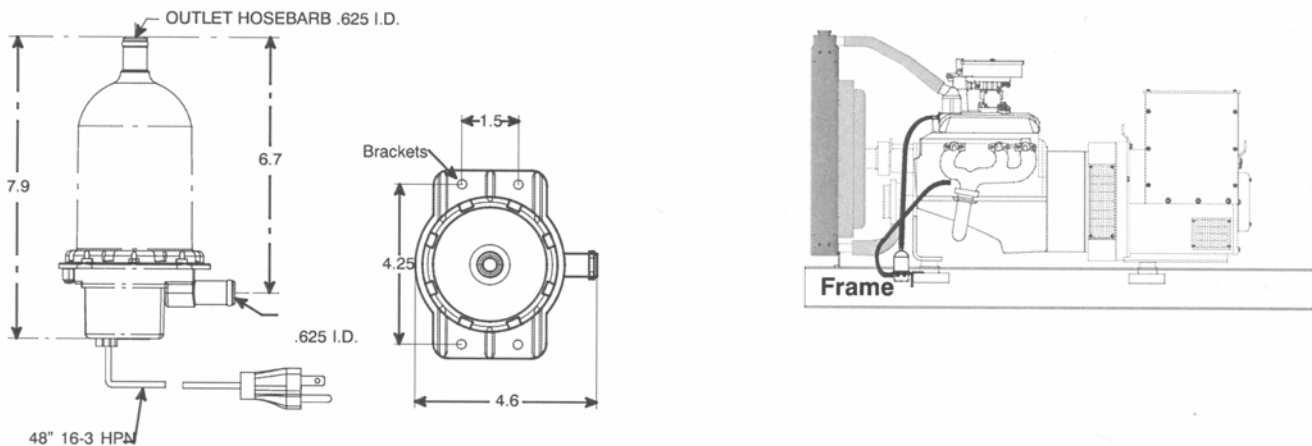

**Block Heater** (refer to block heater manual for specific details)

1. The block heater is mounted as shown in Figure A-3.
2. Connect the AC power cord to shore power outlet.



## Silencers

Refer to enclosure procedure to install silencer when enclosure is present.  
Industrial Silencer for Open Skid Mount Units – Provides silenced exhaust for up to 11 dBA sound attenuation. Kit includes engine adapters, flex pipe, clamps, silencer, and rain cap.  
Critical Silencer for Open Skid Mount Units – Provides silenced exhaust for up to 18 dBA sound attenuation. Kit includes engine adapters, flex pipe, clamps, silencer, and rain cap.

**Figure A-4**

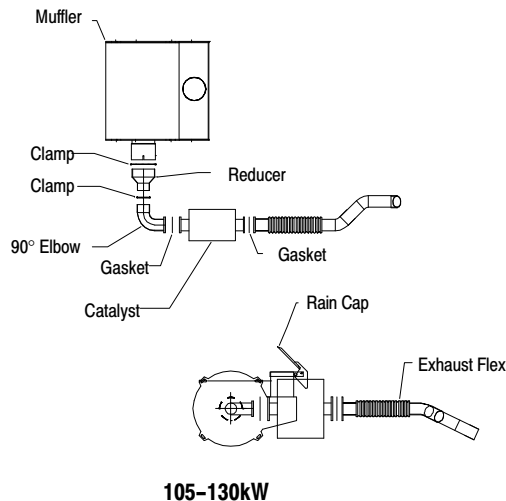
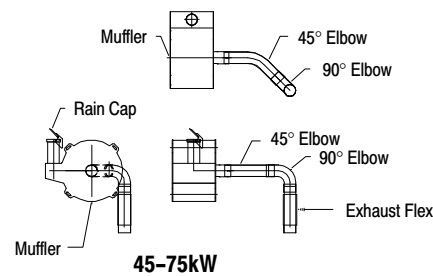
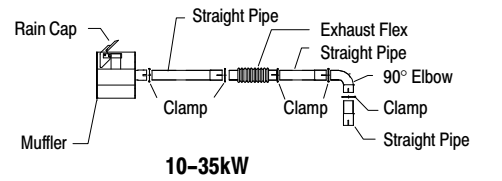

**Silencer** (refer to Figure A-4 for specific details)

1. Attach the Silencer to the Exhaust Output of the engine, refer to Figure B-4.
2. Use correct size clamp to attach extension pipe to Exhaust Output pipe from engine.
3. Be sure the Extension pipe fits securely over Exhaust Output pipe so that no exhaust leaks can occur.

LY000125

## Flexible Fuel Lines

A flexible fuel line can be installed at the fuel pressure regulator to make connection to the fuel main shutoff valve easier. Either 1-1/4" or 2" fittings may be specified.

**Figure A-5 Fuel Strainer and Flex Fuel Line Connections**

- GLCFFL1 3/4" NPT Male fittings, 12" long
- GLCFFL2 1 - 1/4" NPT Male fittings, 18" long
- GLCFFL3 2" NPT Male fittings, 12" long
  
- GLCFS1 3/4" NPT Fuel Strainer female Inlet, male outlet.
- GLCFS3 2" NPT Fuel Strainer female Inlet, male outlet.

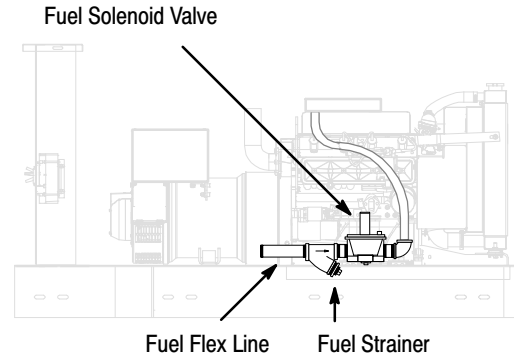

**Installation:** Use appropriate thread sealer as required by plumbing codes.

1. Thread Fuel strainer onto NPT close pipe nipple.
3. Thread Flex Fuel Line into Fuel Strainer input.
4. Connect other end of Flex Fuel Line to site fuel supply pipe as required by plumbing codes.

## E-Stop

E-Stop Switch Kit – Mounts to an Enclosure remote from the Genset to provide easy access to shut down engine with the press of a button. Connects to Remote Run Terminals on genset. Must be adapted for remote mounting when used with open skid mount units.

**Figure A-6**

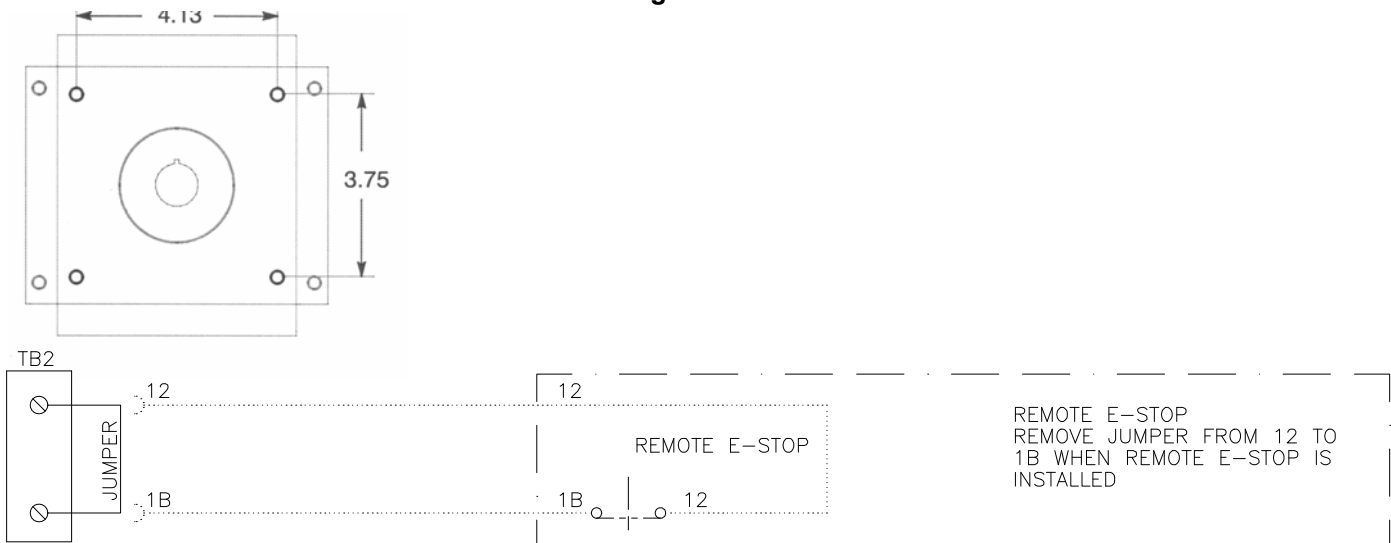

**Installation:**

1. Locate and drill 4 holes shown in Figure A-6.
2. Mount the E-Stop Switch box to the enclosure,
3. Install the E-Stop assembly into the E-Stop Switch box enclosure.
4. Connect the E-Stop Switch cable into the connections for GLCESS.

## Remote Annunciators

Remote Annunciator provides remote annunciation of faults and generator status. Individual fault conditions are remotely monitored using both visual LED lights & audible alarm annunciation. Lamp test and alarm horn silence pushbuttons are provided. Each fault is individually programmable for audible horn operation and alarm labels are field configurable. Requires 12VDC 100mA power supply to operate (engine starting battery can be power supply).” Maximum distance from the controller is 656ft(200m). For GLC all CAN Address jumpers are removed to select address #1.

Figure A-7 Intelilite Remote Annunciator

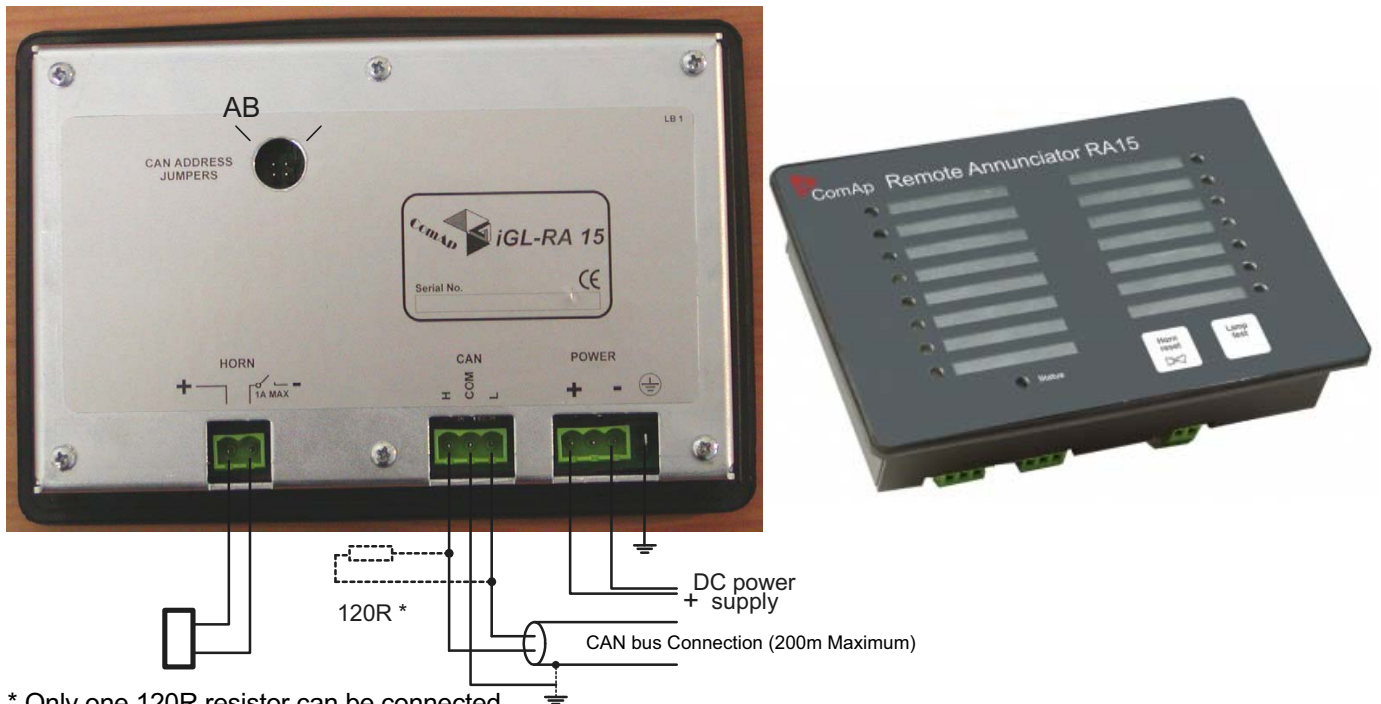

\* Only one 120R resistor can be connected to the CAN bus (If it is the last device on the network (termination)).

---

## **Radiator Duct Flange**

Radiator Duct Flange for Open Skid Mount – Provides easy connection to air ducting to carry away hot air from engine radiator. Duct flange mounts to front of engine radiator. Add 3” to length.

**Figure A-8**

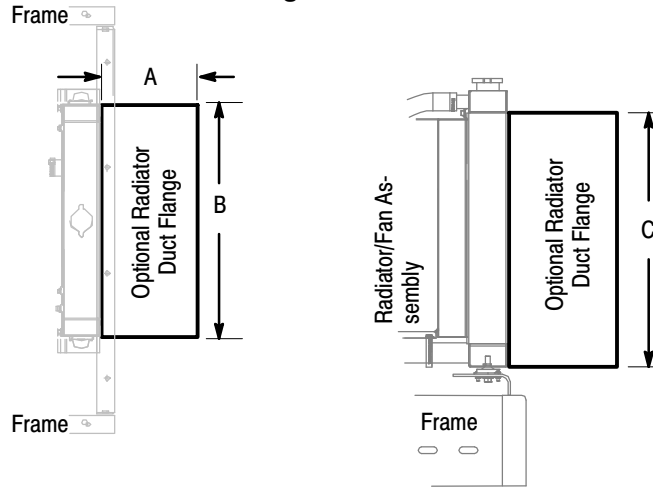

**Table A-1 Mounting Dimensions**

<b>Generator</b>	<b>A</b>	<b>B</b>	<b>C</b>
IGLC25	3.00	22.00	20.00
IGLC35	3.00	26.00	26.70
IGLC45-75	3.00	26.38	29.50
IGLC105	3.00	26.38	29.50
IGLC130	3.00	26.63	29.50

## Appendix B Series GLC Information & Wiring Diagrams

---

### GLC Circuit Breaker Wire Size (Line Side)

Circuit Breaker Size	Wire Size AWG or kcmil	Qty /Phase	Type of Conductor	Ampacity @ 600VAC
20	10	1	THHN, THWN, XHHW	40
30	10	1	THHN, THWN, XHHW	40
40	8	1	THHN, THWN, XHHW	55
50	8	1	THHN, THWN, XHHW	55
60	6	1	THHN, THWN, XHHW	75
70	6	1	THHN, THWN, XHHW	75
80	4	1	THHN, THWN, XHHW	95
90	4	1	THHN, THWN, XHHW	95
100	2	1	THHN, THWN, XHHW	130
110	2	1	THHN, THWN, XHHW	130
125	1	1	THHN, THWN, XHHW	150
150	1	1	THHN, THWN, XHHW	150
175	2/0	1	THHN, THWN, XHHW	195
200	4/0	1	THHN, THWN, XHHW	260
225	4/0	1	THHN, THWN, XHHW	260
250	4/0	1	THHN, THWN, XHHW	260
300	300	1	THHN, THWN, XHHW	320
350	400	1	THHN, THWN, XHHW	380
400	500	1	THHN, THWN, XHHW	430
450	4/0	2	THHN, THWN, XHHW	520
500	4/0	2	THHN, THWN, XHHW	520
600	300	2	THHN, THWN, XHHW	640
700	400	2	THHN, THWN, XHHW	760
800	500	2	THHN, THWN, XHHW	860

**Wiring Diagrams** Wiring diagrams for these generators are contained on the following pages of this appendix.





Figure B-11 Single Phase Diagram

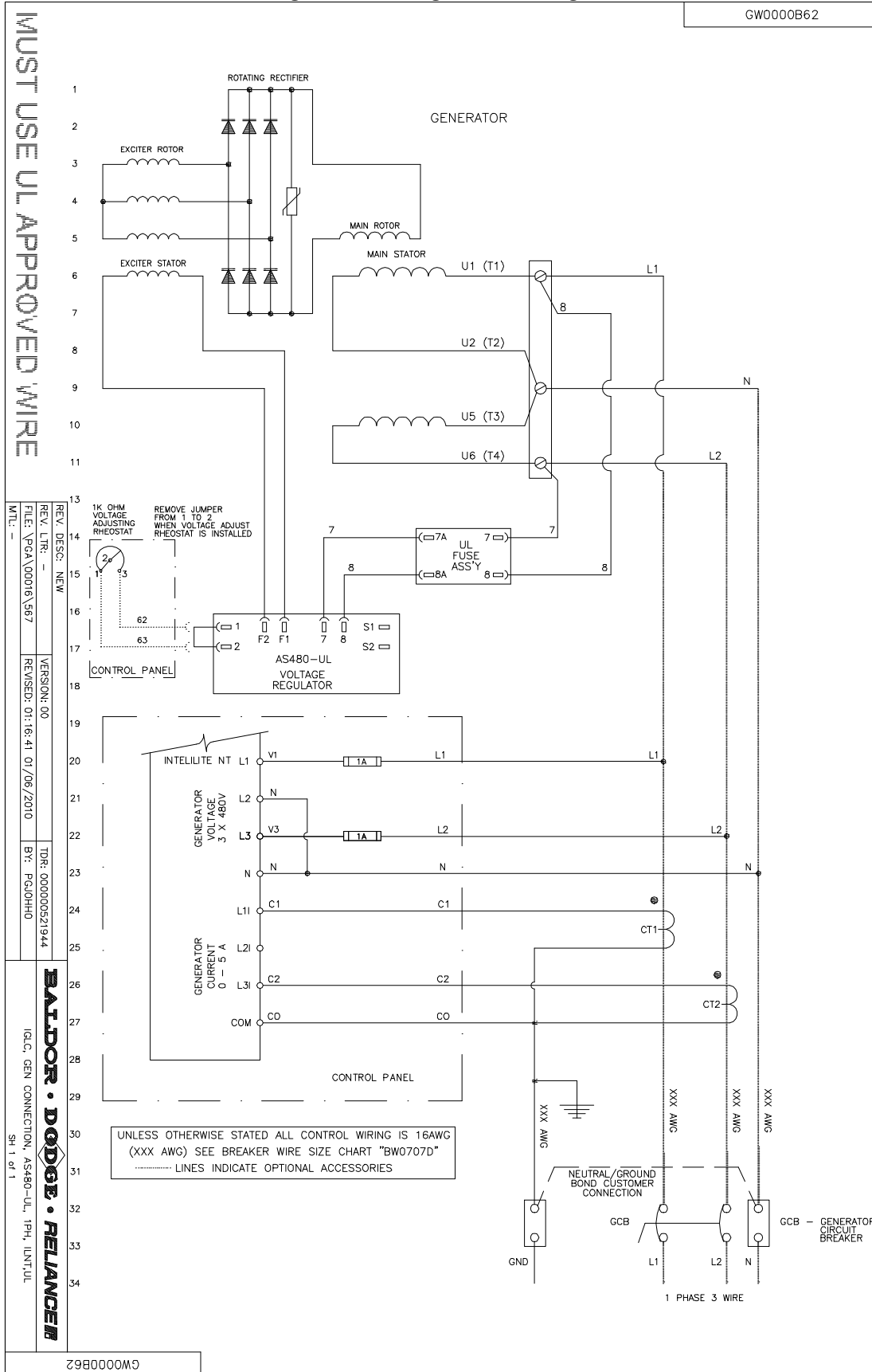

MUST USE UL APPROVED WIRE

REV. DESG: NEW  
 REV. LTR: -  
 FILE: \pca\00016\567  
 MTL: -  
 VERSION: 00  
 REVISED: 01:16:41 01/06/2010  
 TOR: 000000521944  
 BVT: PLOJHHO

**BALDOR • DODGE • RELANCE**  
 I&C, GEN CONNECTION, AS480-UL, 1PH, LNT,UL  
 SH 1 of 1

GW0000B62

GW0000B62



Figure B-12 Three Phase Diagram

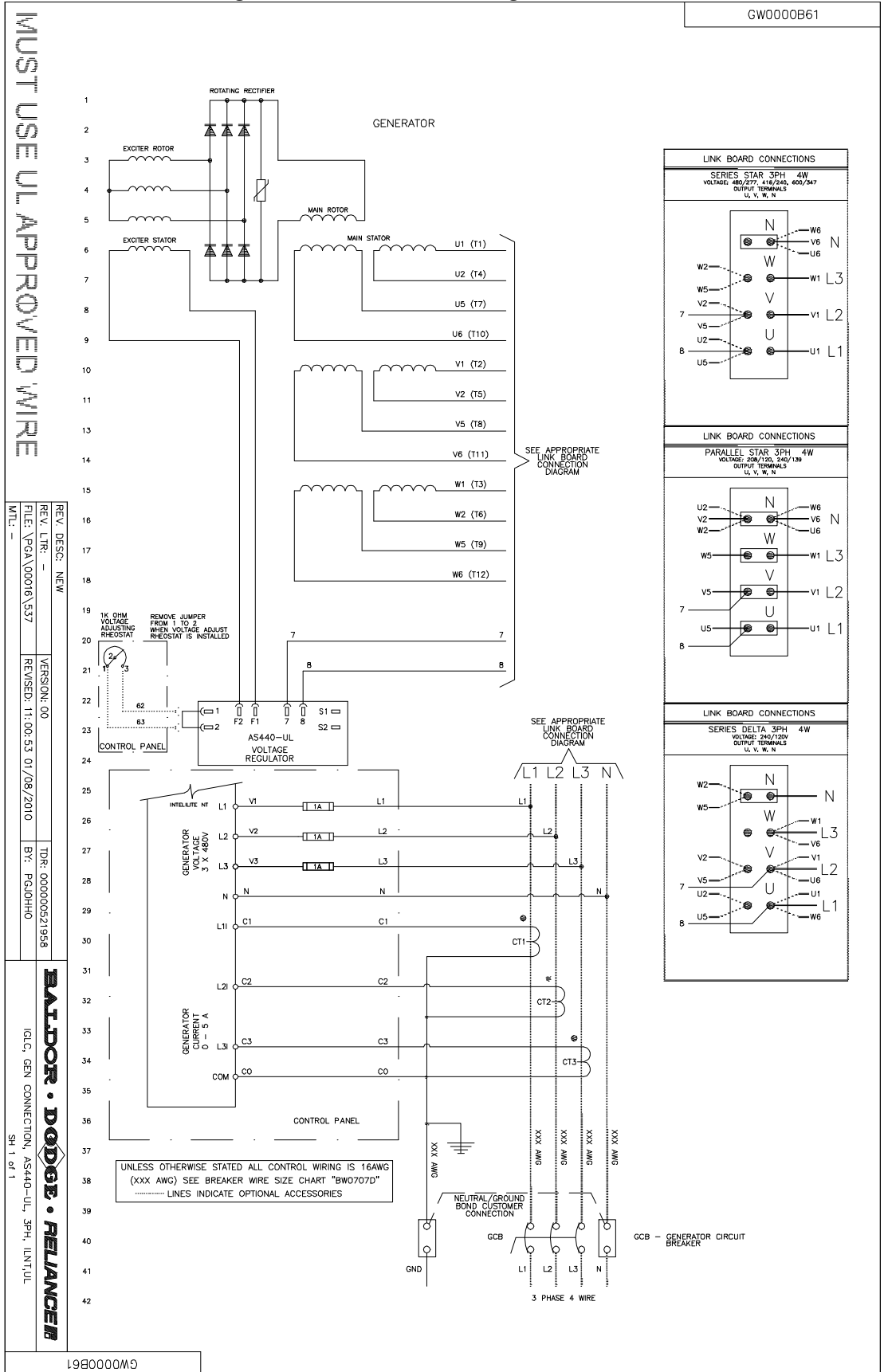

Figure B-13 DC Schematic for 10-25kW

MUST USE UL APPROVED WIRE

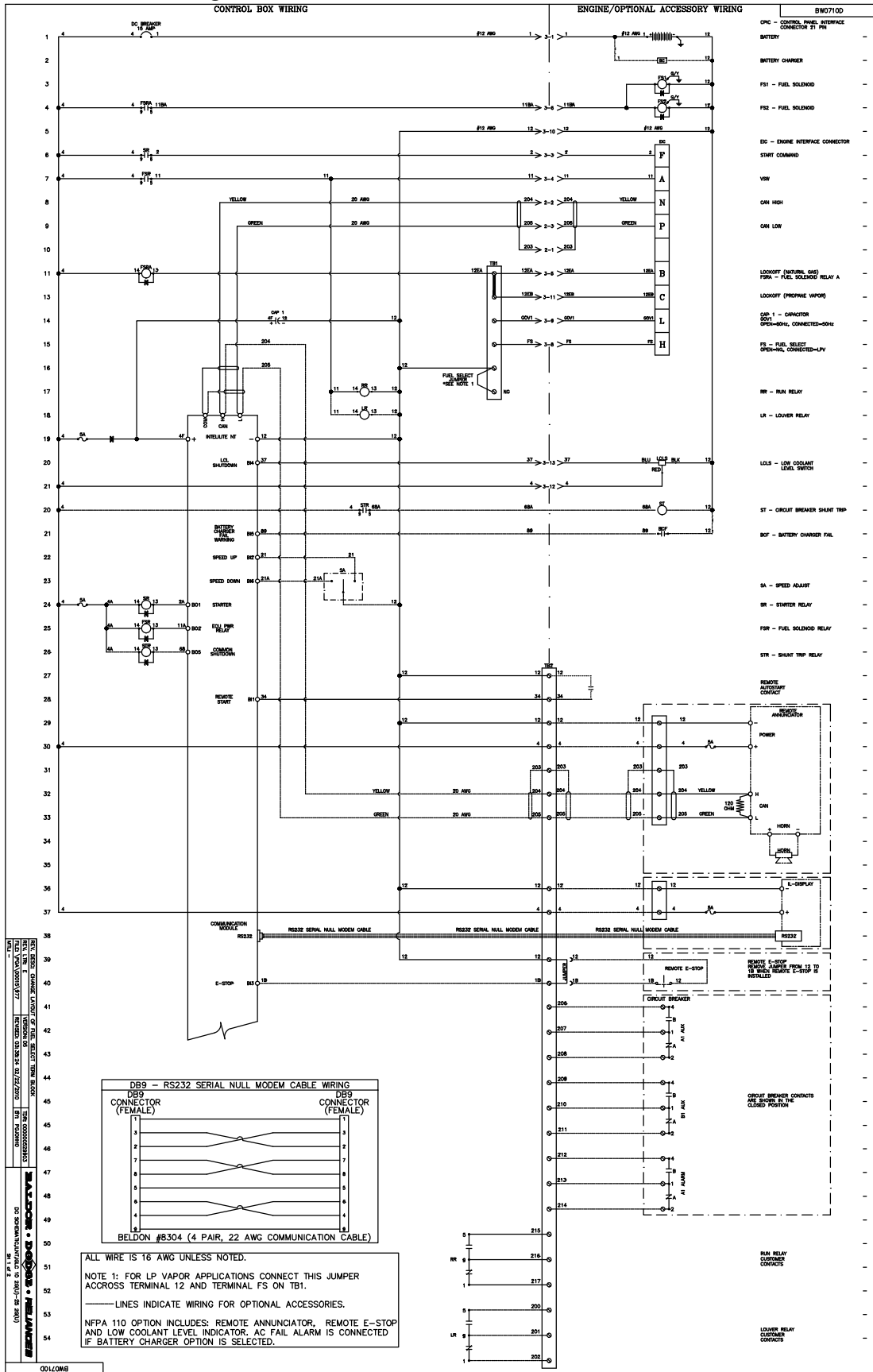

Figure B-14 DC Schematic for 10-25kW Continued

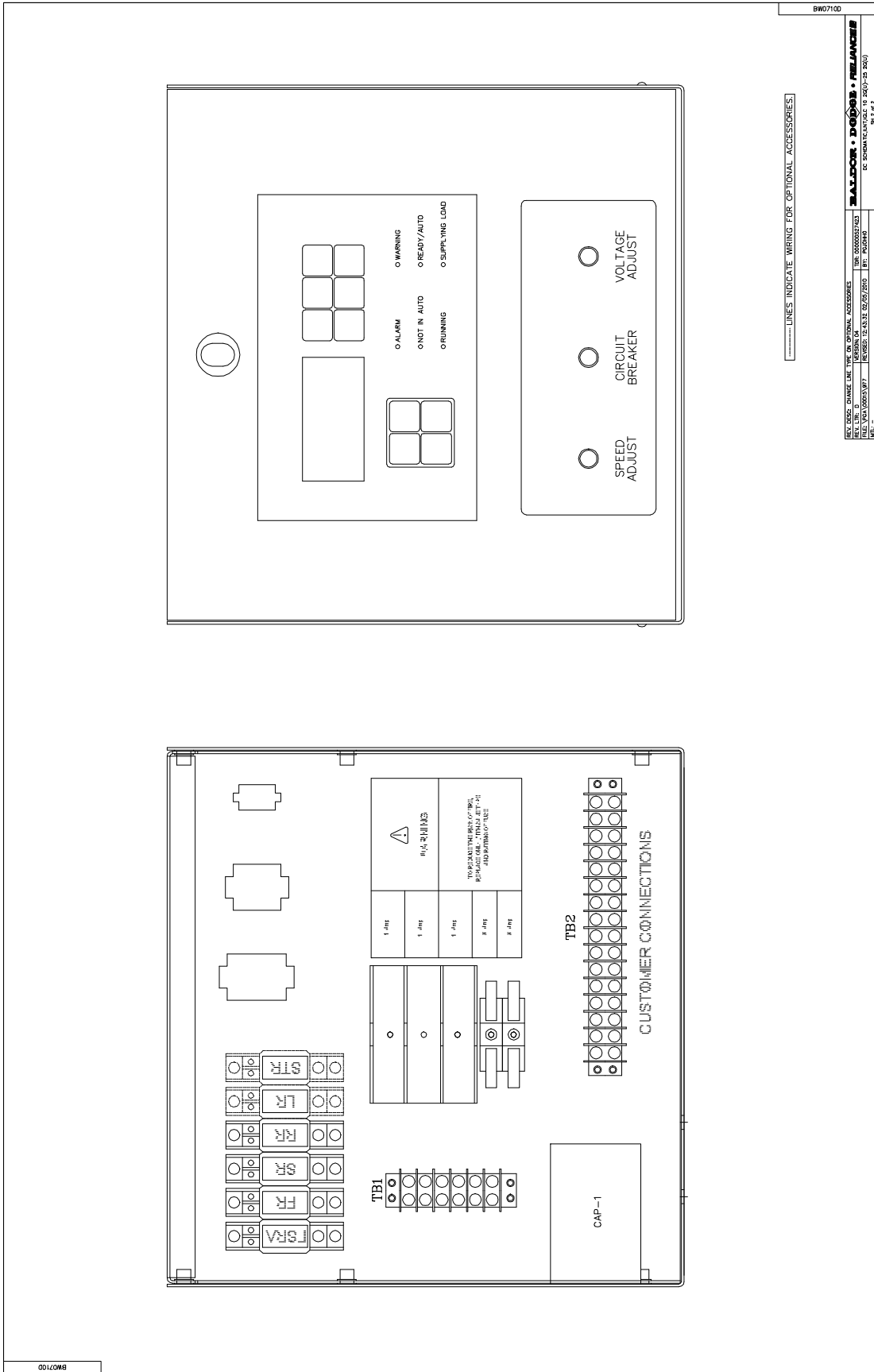

Figure B-15 DC Schematic for 35-130kW

MUST USE UL APPROVED WIRE

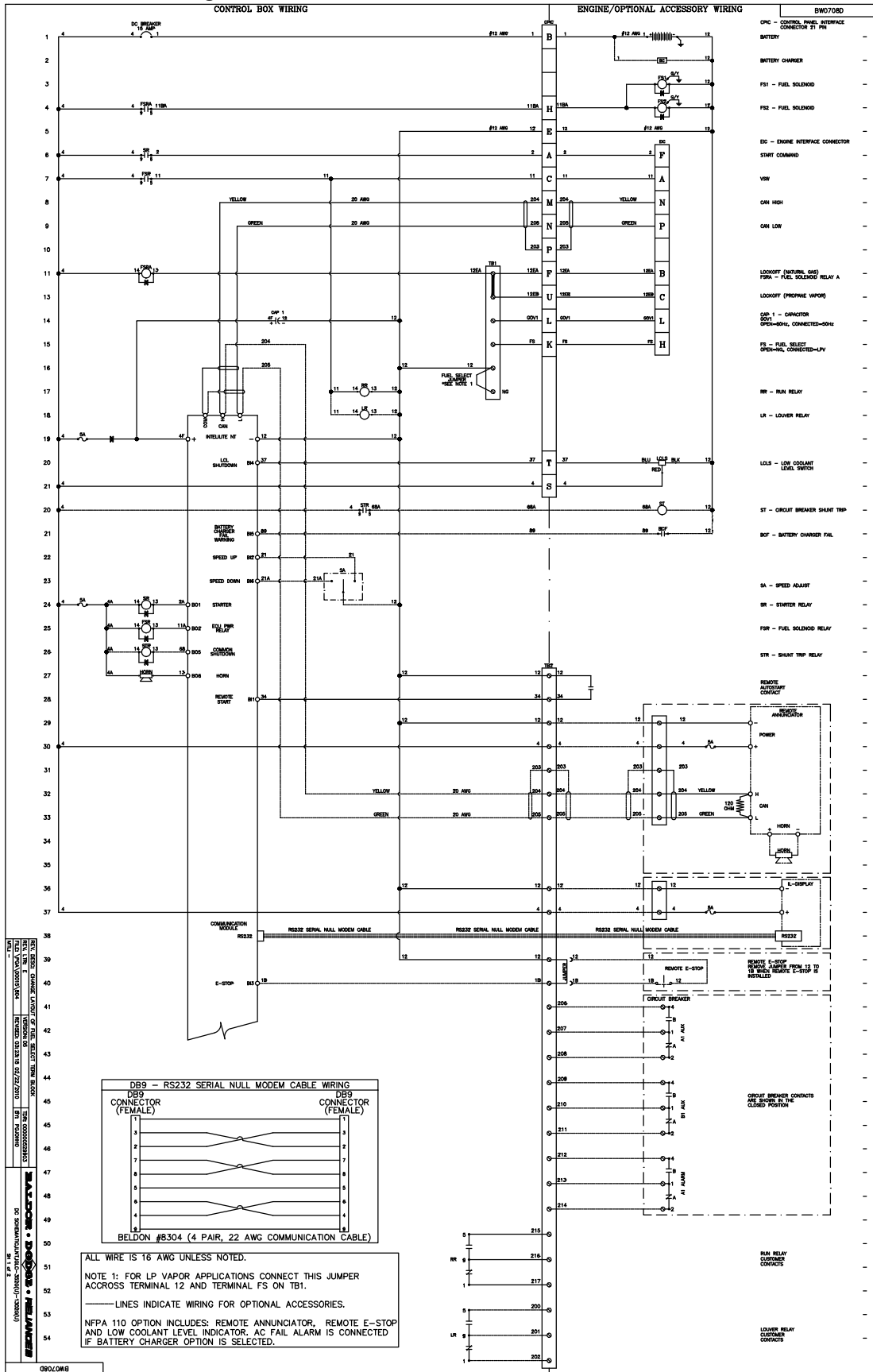

Figure B-16 DC Schematic for 35–130kW Continued

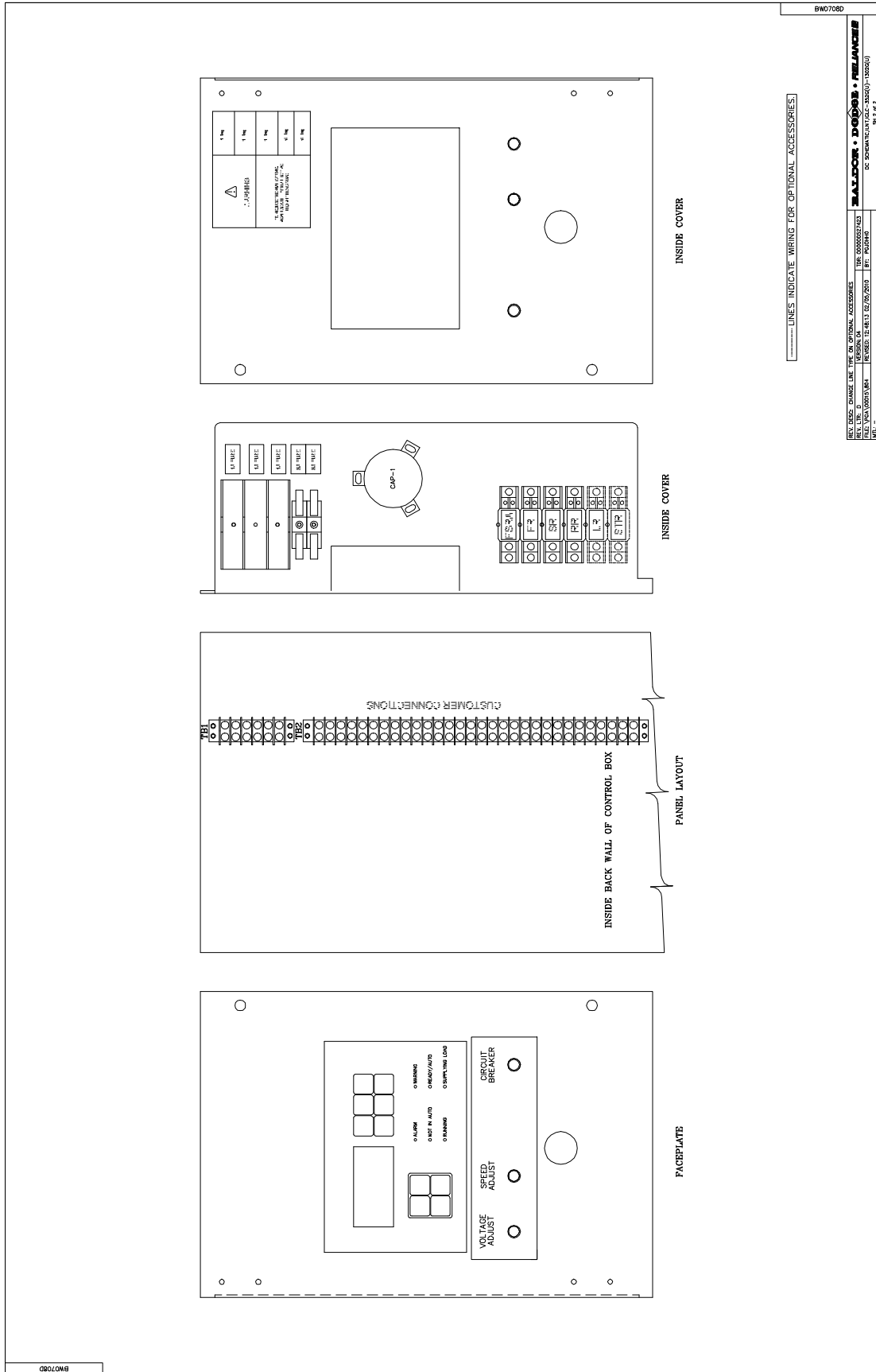
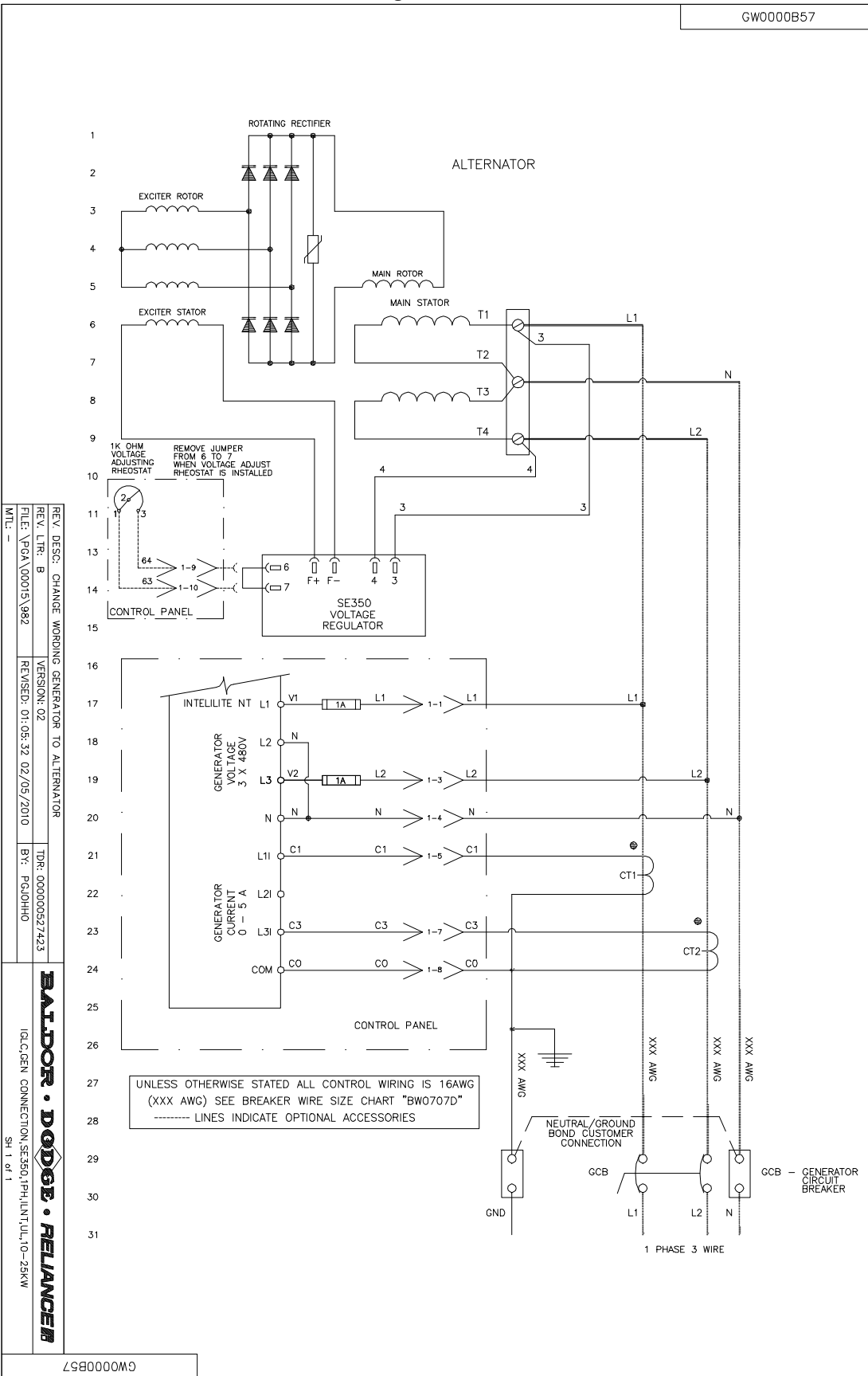

Figure B-17

GW000B57



REV. DESC: CHANGE WIRING GENERATOR TO ALTERNATOR  
 REV. LTR: B  
 FILE: \PGA\00015\982  
 MTL: -  
 VERSION: 02  
 REVISED: 01:05:32 02/05/2010  
 DTR: 000000527423  
 BY: PCJ0HHO

**BALDOR • DODGE • RELIANCE**  
 IGC, GEN CONNECTION, SE350, 1PH, INT, UL, 10-25KW  
 SH 1 of 1

GW000B57

Figure B-18

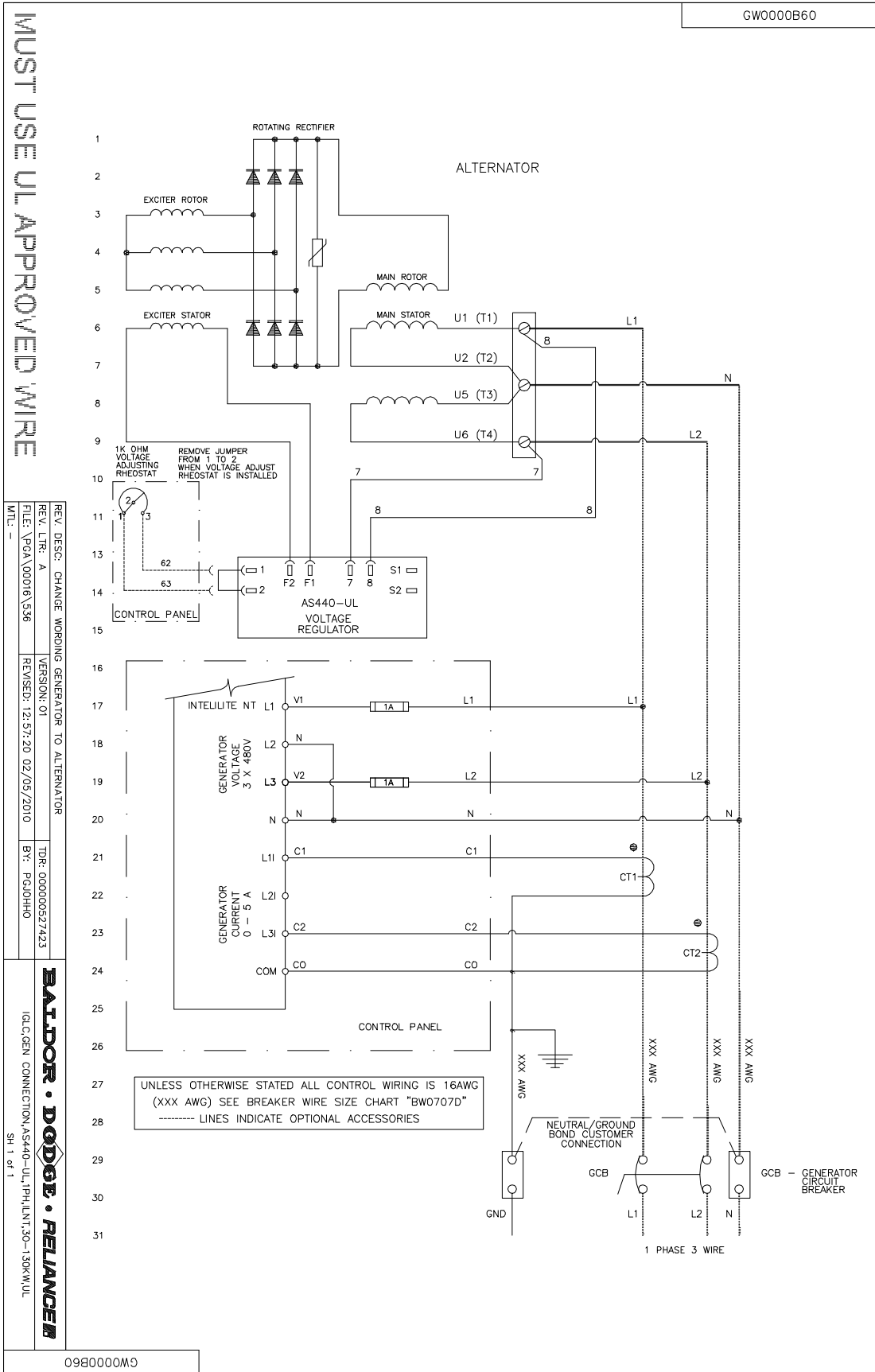

Figure B-19

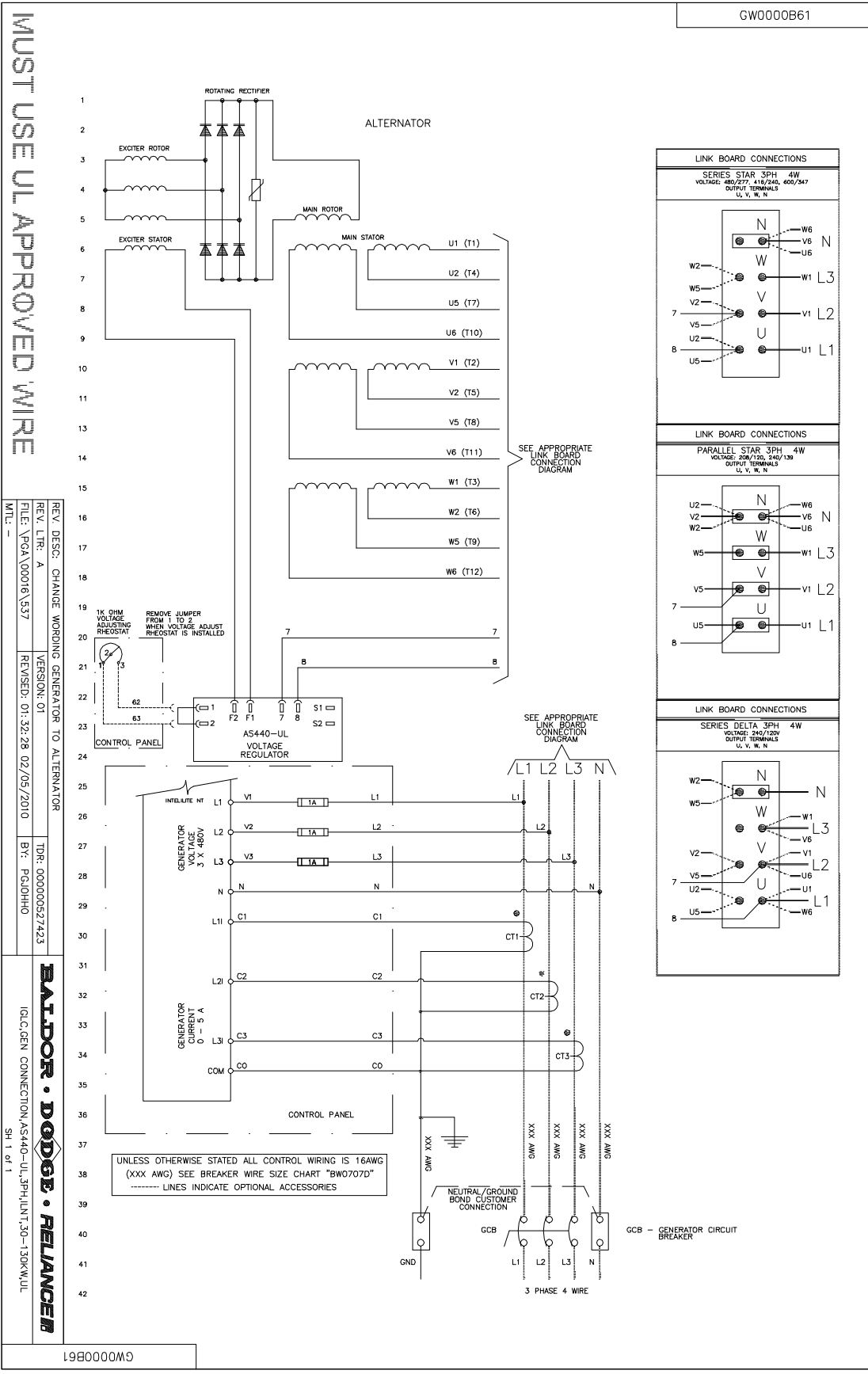



Figure B-20

GW000B62

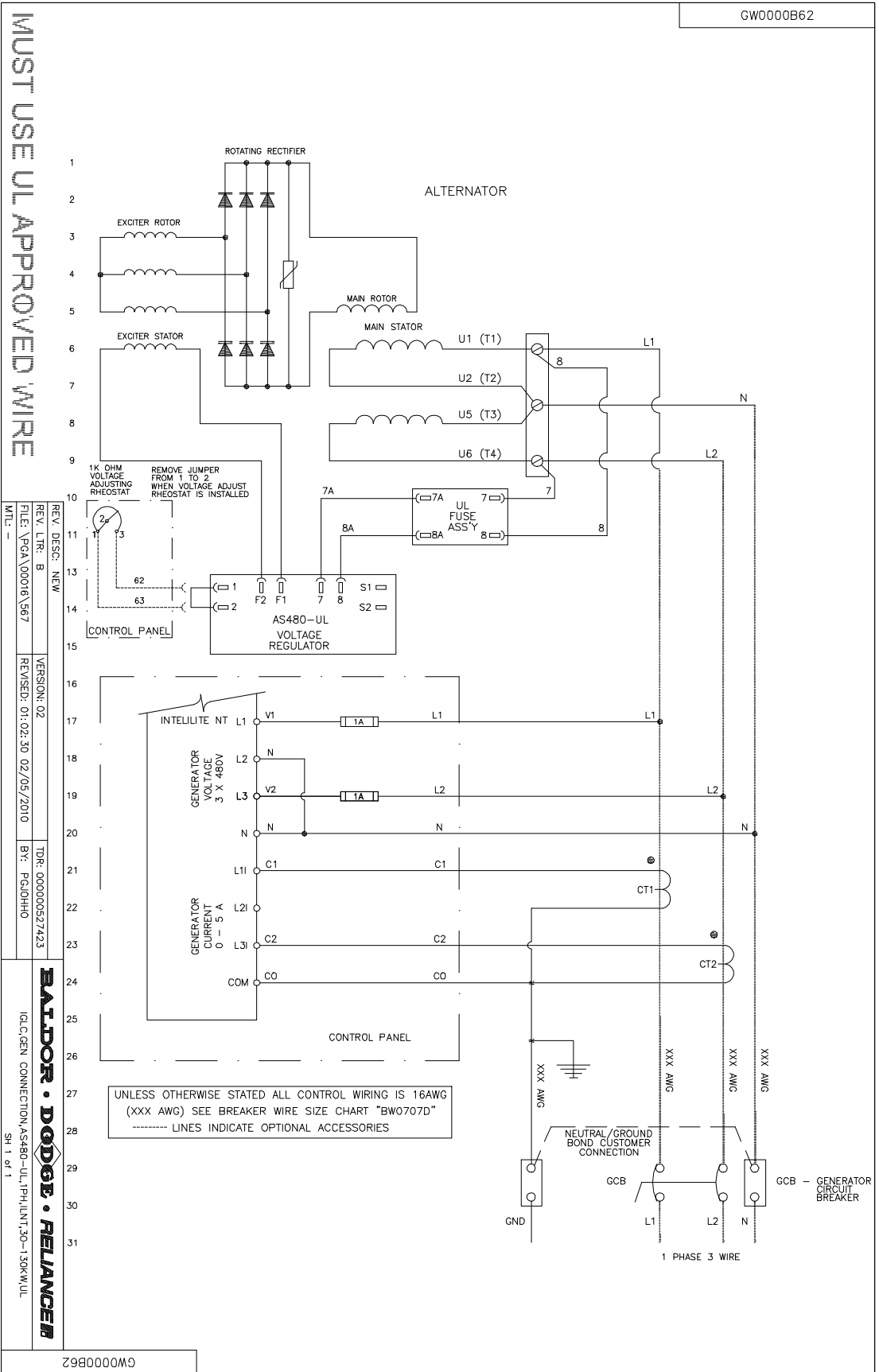
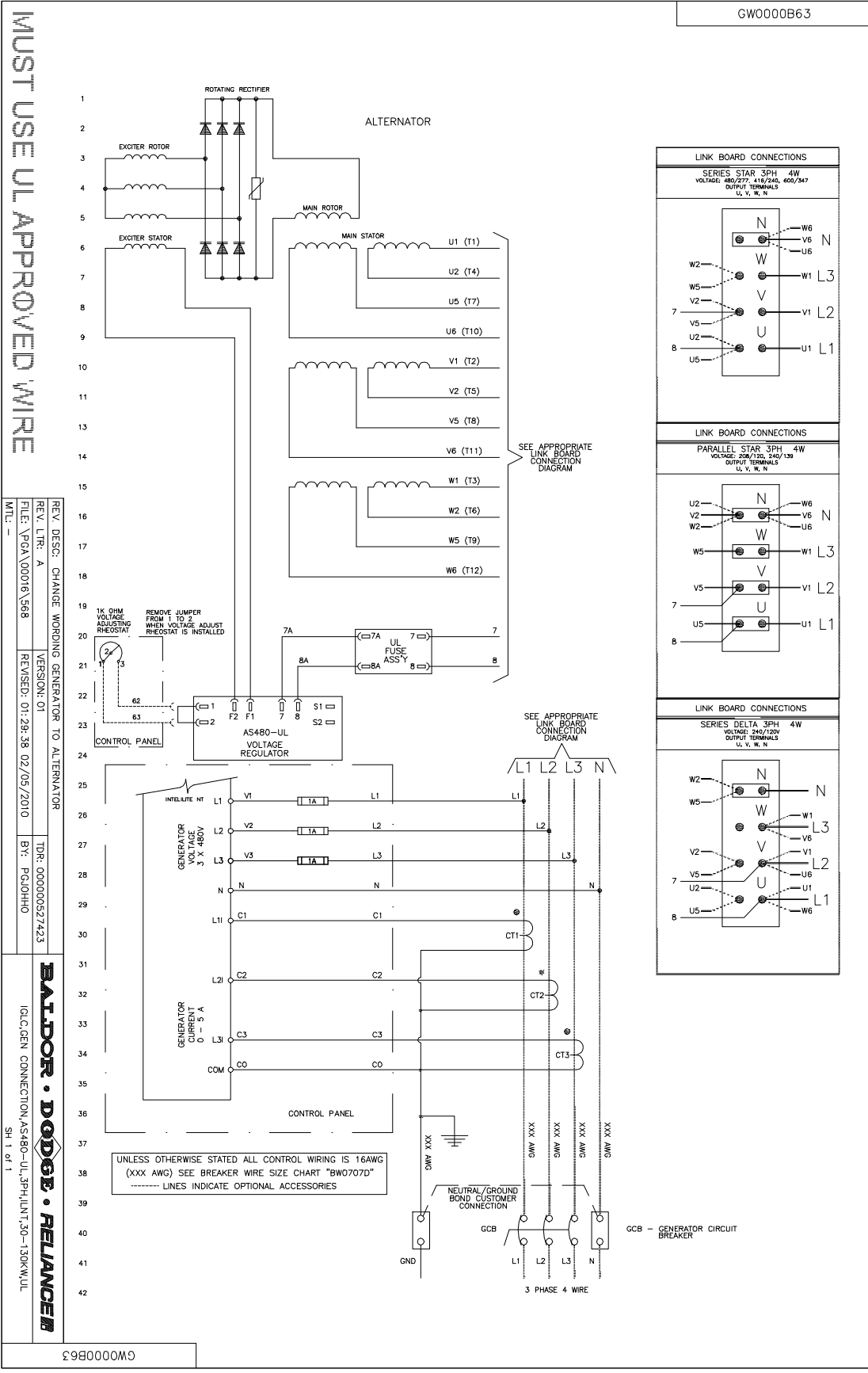

Figure B-21



MUST USE UL APPROVED WIRE

REV. LTR: A  
FILE: \PGA\00016\568  
REVISED: 01:29:38 02/05/2010  
VERSION: 01  
DR: 000000527423  
BY: PCJHHO

REV. DESC: CHANGE WIRING GENERATOR TO ALTERNATOR  
BALDOR • DODGE • RELANCE

GW0000B63

Figure B-22

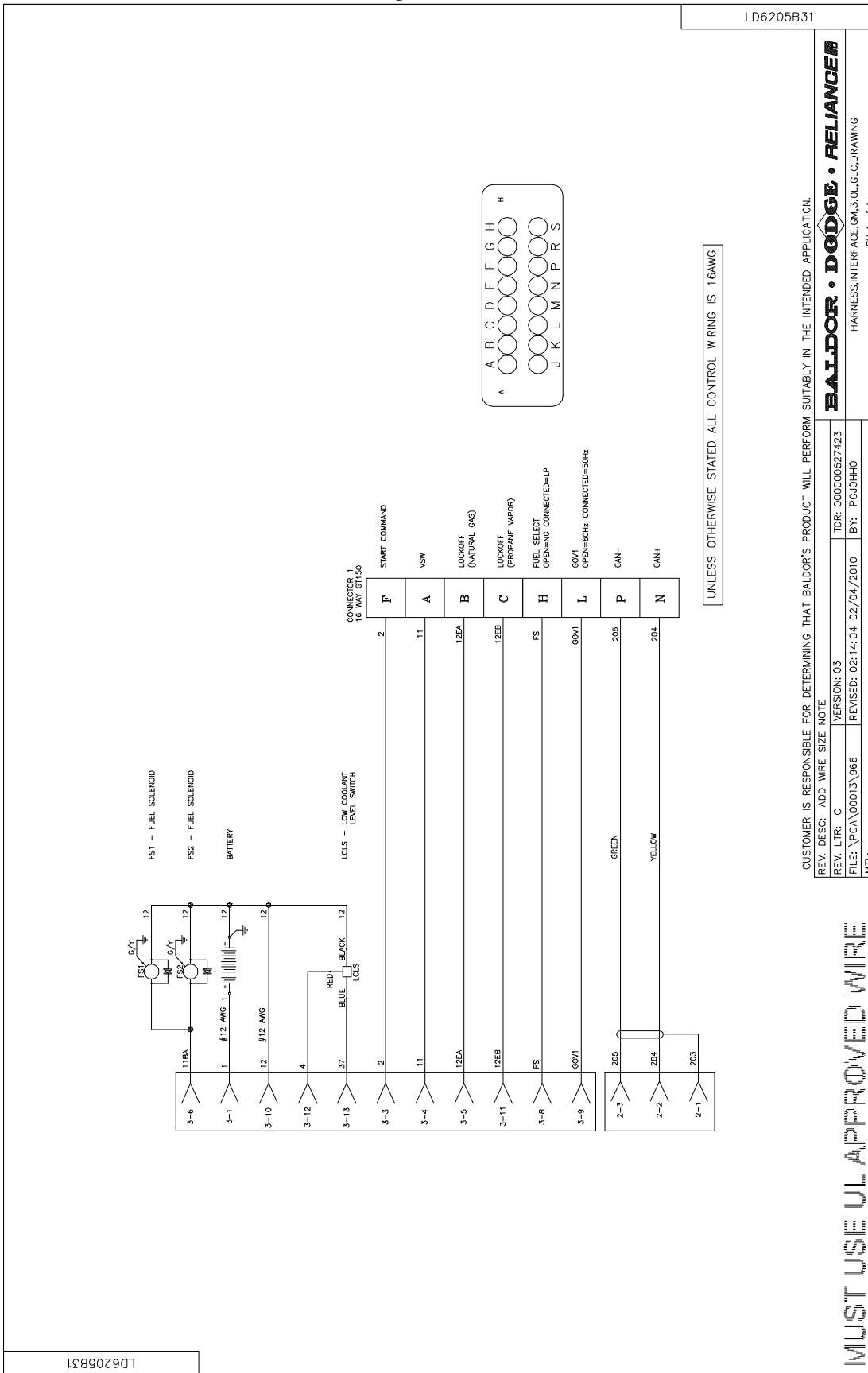
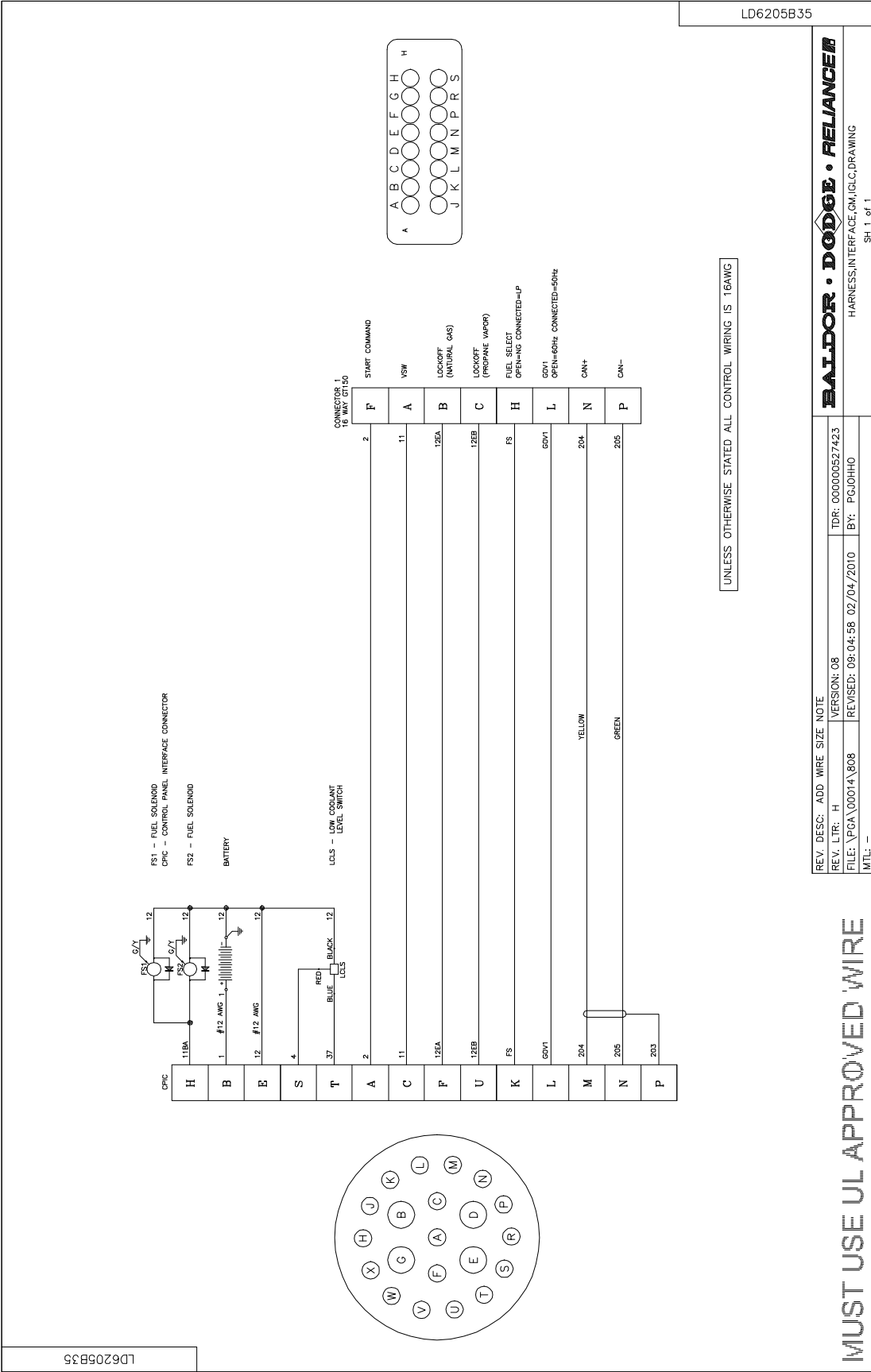

Figure B-23



---

---

---

---

## Baldor District Offices

### UNITED STATES

#### ARIZONA PHOENIX

4211 S 43RD PLACE  
PHOENIX, AZ 85040  
PHONE: 602-470-0407  
FAX: 602-470-0464

#### ARKANSAS

**CLARKSVILLE**  
1001 COLLEGE AVE.  
CLARKSVILLE, AR 72830  
PHONE: 479-754-9108  
FAX: 479-754-9205

#### CALIFORNIA LOS ANGELES

6480 FLOTILLA  
COMMERCE, CA 90040  
PHONE: 323-724-6771  
FAX: 323-721-5859

#### HAYWARD

21056 FORBES STREET  
HAYWARD, CA 94545  
PHONE: 510-785-9900  
FAX: 510-785-9910

#### COLORADO

**DENVER**  
3855 FOREST STREET  
DENVER, CO 80207  
PHONE: 303-623-0127  
FAX: 303-595-3772

#### CONNECTICUT

**WALLINGFORD**  
65 SOUTH TURNPIKE ROAD  
WALLINGFORD, CT 06492  
PHONE: 203-269-1354  
FAX: 203-269-5485

#### FLORIDA

**TAMPA/PUERTO RICO/  
VIRGIN ISLANDS**  
3906 EAST 11TH AVENUE  
TAMPA, FL 33605  
PHONE: 813-248-5078  
FAX: 813-247-2984

#### GEORGIA

**ATLANTA**  
62 TECHNOLOGY DR.  
ALPHARETTA, GA 30005  
PHONE: 770-772-7000  
FAX: 770-772-7200

#### ILLINOIS

**CHICAGO**  
4 SAMMONS COURT  
BOLINGBROOK, IL 60440  
PHONE: 630-296-1400  
FAX: 630-226-9420

#### INDIANA

**INDIANAPOLIS**  
5525 W. MINNESOTA STREET  
INDIANAPOLIS, IN 46241  
PHONE: 317-246-5100  
FAX: 317-246-5110

#### IOWA

**DES MOINES**  
1800 DIXON STREET, SUITE C  
DES MOINES, IA 50316  
PHONE: 515-263-6929  
FAX: 515-263-6515

#### MARYLAND

**BALTIMORE**  
6660 SANTA BARBARA RD.  
SUITE 22-24  
ELKRIDGE, MD 21075  
PHONE: 410-579-2135  
FAX: 410-579-2677

#### MASSACHUSETTS

**BOSTON**  
6 PULLMAN STREET  
WORCESTER, MA 01606  
PHONE: 508-854-0708  
FAX: 508-854-0291

#### MICHIGAN

**DETROIT**  
5993 PROGRESS DRIVE  
STERLING HEIGHTS, MI 48312  
PHONE: 586-978-9800  
FAX: 586-978-9969

#### MINNESOTA

**MINNEAPOLIS**  
21080 134TH AVE. NORTH  
ROGERS, MN 55374  
PHONE: 763-428-3633  
FAX: 763-428-4551

#### MISSOURI

**ST LOUIS**  
422 INDUSTRIAL DRIVE  
MARYLAND HEIGHTS, MO 63043  
PHONE: 314-298-1800  
FAX: 314-298-7660

#### KANSAS CITY

1501 BEDFORD AVENUE  
NORTH KANSAS CITY, MO 64116  
PHONE: 816-587-0272  
FAX: 816-587-3735

#### NEW YORK

**AUBURN**  
ONE ELLIS DRIVE  
AUBURN, NY 13021  
PHONE: 315-255-3403  
FAX: 315-253-9923

#### NORTH CAROLINA

**GREENSBORO**  
1220 ROTHERWOOD ROAD  
GREENSBORO, NC 27406  
PHONE: 336-272-6104  
FAX: 336-273-6628

#### OHIO

**CINCINNATI**  
2929 CRESCENTVILLE ROAD  
WEST CHESTER, OH 45069  
PHONE: 513-771-2600  
FAX: 513-772-2219

#### CLEVELAND

8929 FREEWAY DRIVE  
MACEDONIA, OH 44056  
PHONE: 330-468-4777  
FAX: 330-468-4778

#### OKLAHOMA

**TULSA**  
7170 S. BRADEN, SUITE 140  
TULSA, OK 74136  
PHONE: 918-366-9320  
FAX: 918-366-9338

#### OREGON

**PORTLAND**  
20393 SW AVERY COURT  
TUALATIN, OR 97062  
PHONE: 503-691-9010  
FAX: 503-691-9012

#### PENNSYLVANIA

**PHILADELPHIA**  
1035 THOMAS BUSCH  
MEMORIAL HIGHWAY  
PENNSAUKEN, NJ 08110  
PHONE: 856-661-1442  
FAX: 856-663-6363

#### PITTSBURGH

159 PROMINENCE DRIVE  
NEW KENSINGTON, PA 15068  
PHONE: 724-889-0092  
FAX: 724-889-0094

#### TENNESSEE

**MEMPHIS**  
4000 WINCHESTER ROAD  
MEMPHIS, TN 38118  
PHONE: 901-365-2020  
FAX: 901-365-3914

#### TEXAS

**DALLAS**  
3040 QUEBEC  
DALLAS, TX 75247  
PHONE: 214-634-7271  
FAX: 214-634-8874

#### HOUSTON

10355 W. LITTLE YORK RD.  
SUITE 300  
HOUSTON, TX 77041  
PHONE: (281) 977-6500  
FAX: (281) 977-6510

#### UTAH

**SALT LAKE CITY**  
2230 SOUTH MAIN STREET  
SALT LAKE CITY, UT 84115  
PHONE: 801-832-0127  
FAX: 801-832-8911

#### WISCONSIN

**MILWAUKEE**  
1960 S. CALHOUN ROAD  
NEW BERLIN, WI 53151  
PHONE: 262-784-5940  
FAX: 262-784-1215

#### INTERNATIONAL SALES

**FORT SMITH, AR**  
P.O. BOX 2400  
FORT SMITH, AR 72902  
PHONE: 479-646-4711  
FAX: 479-648-5895

#### CANADA

**EDMONTON, ALBERTA**  
4053-92 STREET  
EDMONTON, ALBERTA T6E 6R8  
PHONE: 780-434-4900  
FAX: 780-438-2600

#### TORONTO

**OAKVILLE, ONTARIO**  
2750 COVENTRY ROAD  
OAKVILLE, ONTARIO L6H 6R1  
PHONE: 905-829-3301  
FAX: 905-829-3302

#### MONTREAL, QUEBEC

5155, J.A. BOMBARDIER  
ST-HUBERT (QUÉBEC) CANADA  
J3Z 1G4  
PHONE: 514-933-2711  
FAX: 514-933-8639

#### VANCOUVER, BRITISH COLUMBIA

1538 KEBET WAY  
PORT COQUITLAM,  
BRITISH COLUMBIA V3C 5M5  
PHONE: 604-421-2822  
FAX: 604-421-3113

#### WINNIPEG, MANITOBA

54 PRINCESS STREET  
WINNIPEG, MANITOBA R3B 1K2  
PHONE: 204-942-5205  
FAX: 204-956-4251

#### AUSTRALIA

UNIT 3, 6 STANTON ROAD  
SEVEN HILLS, NSW 2147, AUSTRALIA  
PHONE: (61) (2) 9674 5455  
FAX: (61) (2) 9674 2495

UNIT 8, 5 KELLETTS ROAD  
ROWVILLE, VICTORIA, 3178 AUSTRALIA  
PHONE: (61) (3) 9753 4355  
FAX: (61) (3) 9753 4366

#### EL SALVADOR

RESIDENCIAL PINARES DE SUIZA  
POL. 15 #44,  
NVA. SAN SALVADOR, EL SALVADOR  
PHONE: +503 2288-1519  
FAX: +503 2288-1518

#### CHILE

LUIS THAYER OJEDA 166,  
OF 402 - PROVIDENCIA  
SANTIAGO, CHILE  
PHONE: +56 2 816 9900

#### CHINA

160 SONG SHENG ROAD  
SONGJIANG INDUSTRY ZONE  
SHANGHAI 201613, CHINA  
PHONE: +86 21 5760 5335  
FAX: +86 21 5760 5336

#### GERMANY

DIESELSTRASSE 22  
D-85551 KIRCHHEIM  
MUNICH, GERMANY  
PHONE: +49 89 90 5080  
FAX: +49 89 90 50 8492

#### INDIA

14, COMMERCE AVENUE  
MAHAGANESH COLONY  
PAUD ROAD  
PUNE - 411038  
MAHARASHTRA, INDIA  
PHONE: +91 20 25 45 27 / 18  
FAX: +91 20 25 45 27 19

#### INDONESIA

TALavera OFFICE PARK,  
28TH FLOOR, SUITE M18  
JI. T.B. SIMATUPANG, KAV. 22-26  
JAKARTA 12430, INDONESIA  
PHONE: +62 21 7599 9879  
FAX: +62 21 7599 9878

#### ITALY

BALDOR ASR AG  
SUCCURSALE DI MENDRISIO  
VIA BORROMINI, 20A  
CH-6850 MENDRISIO  
SWITZERLAND  
PHONE: 0041 91 640 99 50  
FAX: 0041 91 630 26 33

#### JAPAN

DIA BLDG 802,  
2-21-1 TSURUYA-CHO,  
KANAGAWA-KU  
YOKOHAMA, 221-0835, JAPAN  
PHONE: 81-45-412-4506  
FAX: 81-45-412-4507

#### MEXICO

**LEON, GUANAJUATO**  
KM. 2.0 BLVD. AEROPUERTO  
LEÓN 37545, GUANAJUATO, MÉXICO  
PHONE: +52 477 761 2030  
FAX: +52 477 761 2010

#### MIDDLE EAST & NORTH AFRICA

VSE INTERNATIONAL CORP.  
P. O. BOX 5618  
BUFFALO GROVE, IL 60089-5618  
PHONE: 847 590 5547  
FAX: 847 590 5587

#### PANAMA

AVE. RICARDO J. ALFARO  
EDIFICIO SUN TOWERS MALL  
PISO 2, LOCAL 55  
CIUDAD DE PANAMÁ, PANAMÁ  
PHONE: +507 236-5155  
FAX: +507 236-0591

#### SINGAPORE

18 KAKI BUKIT ROAD 3, #03-09  
ENTREPRENEUR BUSINESS CENTRE  
SINGAPORE 415978  
PHONE: (65) 6744 2572  
FAX: (65) 6747 1708

#### SWITZERLAND

POSTFACH 73  
SCHUTZENSTRASSE 59  
CH-8245 FEUERTHALEN  
SWITZERLAND  
PHONE: +41 52 647 4700  
FAX: +41 52 659 2394

#### TAIWAN

1F, NO 126 WENSHAN 3RD STREET,  
NANTUN DISTRICT,  
TAICHUNG CITY 408  
TAIWAN R.O.C  
PHONE: (886) 4 238 04235  
FAX: (886) 4 238 04463

#### UNITED KINGDOM

6 BRISTOL DISTRIBUTION PARK  
HAWKLEY DRIVE  
BRISTOL BS32 0BF U.K.  
PHONE: +44 1454 850000  
FAX: +44 1454 859001

#### VENEZUELA

AV. ROMA. QTA EL MILAGRO. URB.  
CALIFORNIA NORTE  
CARACAS, 1070  
VENEZUELA  
PHONE/FAX: +58 212 272 7343  
MOBILE: +58 414 114 8623

**WARNING:**  
**CALIFORNIA PROPOSITION 65 WARNING:**  
Engine exhaust from this product contains chemicals known to the state of California to cause cancer, birth defects and other reproductive harm.

**WARNING:**  
**CALIFORNIA PROPOSITION 65 WARNING:**  
Battery posts, terminals and related accessories are known to the state of California to cause cancer, birth defects and other reproductive harm.



**BALDOR**

**World Headquarters**

P.O. Box 2400 Fort Smith, AR 72902-2400 USA Ph: (1) 479.646.4711, Fax: (1) 479.648.5792  
[www.baldor.com](http://www.baldor.com)

